

BASE MINIMUM STEEL AREA (IN <sup>2</sup> /FT)		
ID (IN)	SEPARATE BASE	INTEGRAL PRECAST BASE
48"	0.23	0.15
54"	0.19	0.19
60"	0.25	0.25

**NOTES:**

- MANHOLES SHALL BE CONSTRUCTED IN ACCORDANCE WITH AASHTO M199 UNLESS OTHERWISE SHOWN ON PLANS OR NOTED IN THE WSDOT/APWA STANDARD SPECIFICATIONS.
- HANDHOLDS IN ADJUSTMENT SECTION SHALL HAVE 3" MIN CLEARANCE. STEPS IN MANHOLE SHALL HAVE 6" MIN CLEARANCE. HANDHOLDS SHALL BE PLACED IN ALTERNATING GRADE RINGS OR LEVELING BRICK COURSE WITH A MIN OF ONE HAND HOLD BETWEEN THE LAST STEP AND THE TOP OF THE MANHOLE.
- BASE SHALL BE PRECAST WITH AN INTEGRAL RISER UNLESS OTHERWISE APPROVED BY THE ENGINEER. CHANNEL AND BENCH SHALL BE NON-REINFORCED CLASS 3,000 CONCRETE.
- FOR MANHOLES GREATER THAN 15 FT DEEP, OR FOR MANHOLES WITH DIAMETERS GREATER THAN 60" EXTENDING AT LEAST 4 FT INTO THE WET WEATHER WATER TABLE, THE BASE SHALL EXTEND A DISTANCE BEYOND THE OUTER DIAMETER OF THE MANHOLE SUFFICIENT TO COUNTERACT BUOYANCY FORCES. PROVIDE ANTI-FLOTATION CALCULATIONS.
- PRECAST OR CORED CUTOUTS MUST BE CIRCULAR AND SIZED TO ACCOMMODATE APPROVED RUBBER BOOT CONNECTORS FOR THE APPROPRIATE PIPE SIZES. KNOCKOUTS SHALL NOT BE USED UNLESS OTHERWISE APPROVED BY THE ENGINEER. MAX HOLE SIZE SHALL BE 36", 42", AND 48" FOR 4-FT, 4.5-FT, AND 5-FT MANHOLES, RESPECTIVELY. THE MIN DISTANCE BETWEEN HOLE EDGES SHALL BE 8".
- MANHOLE RINGS AND COVERS SHALL MEET THE STRENGTH REQUIREMENTS OF FEDERAL SPECIFICATION A-A-60005. MATING SURFACES SHALL BE FINISHED TO ASSURE NON-ROCKING FIT WITH ANY COVER POSITION.
- BASE REINFORCING STEEL SHALL BE LOCATED IN THE UPPER HALF OF THE BASE, BELOW THE TOP OF THE SLAB AT A DISTANCE OF  $\frac{1}{3}$  TO  $\frac{1}{2}$  THE THICKNESS OF THE SLAB.
- FINAL BACKFILL SHALL CONFORM TO WSDOT SECTION 9-03.9(3) CSBC, UNLESS OTHERWISE APPROVED BY THE ENGINEER.
- MIN SOIL BEARING VALUE SHALL BE 3,000 LB/SF, AND FOR MANHOLE HEIGHTS OVER 12', MIN SOIL BEARING VALUE SHALL BE 3,800 LB/SF.
- JOINTS SHALL BE TONGUE AND GROOVE CONFORMING TO WSDOT SECTION 7-05.3.

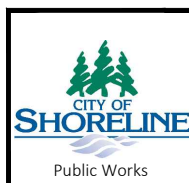

PUBLICATION DATE: **03/01/2024** REVISION DATE: **09/06/2023**  
 STANDARD DETAIL NUMBER: **601** SCALE: **NOT TO SCALE**

**MANHOLE TYPE I - SANITARY**

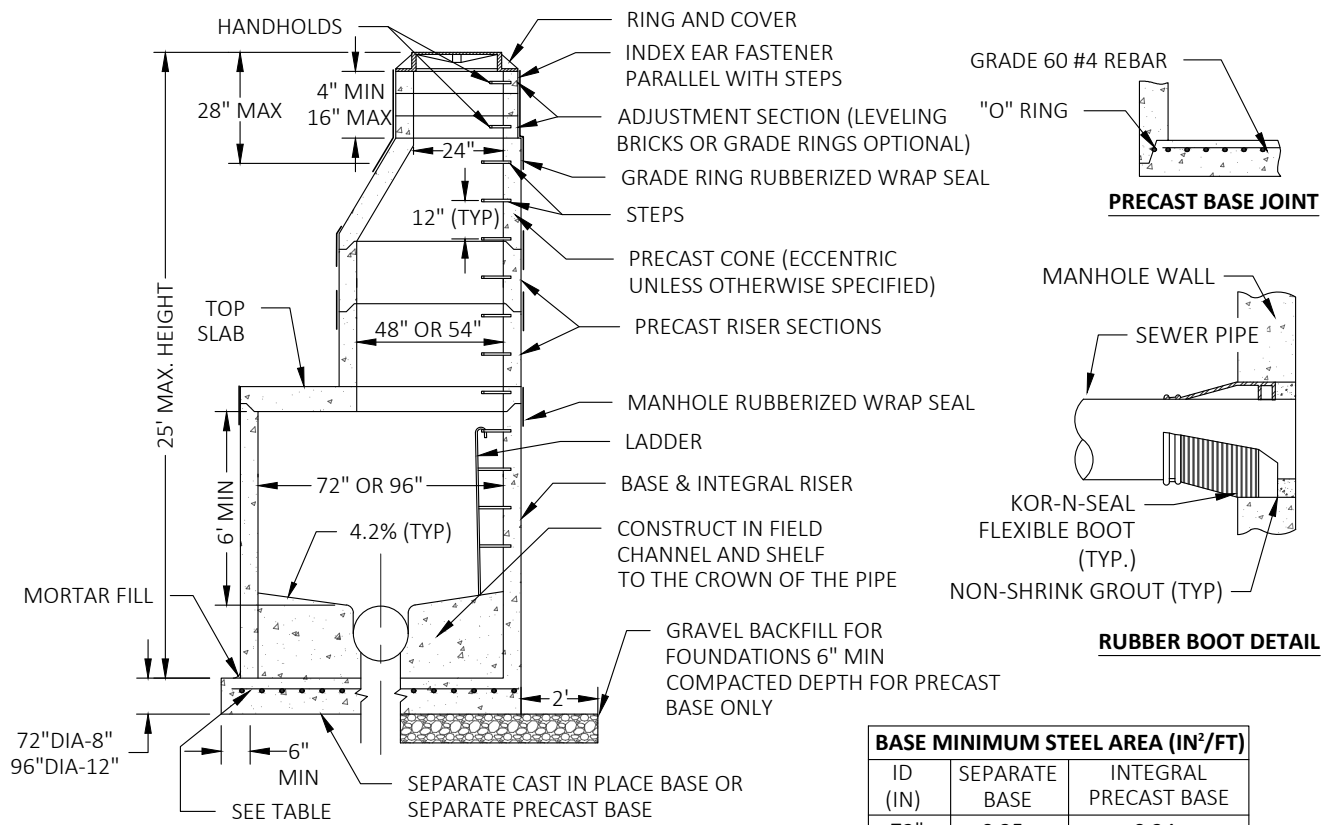

BASE MINIMUM STEEL AREA (IN <sup>2</sup> /FT)		
ID (IN)	SEPARATE BASE	INTEGRAL PRECAST BASE
72"	0.35	0.24
84"-96"	0.39	0.29

**NOTES:**

- MANHOLES SHALL BE CONSTRUCTED IN ACCORDANCE WITH AASHTO M199 UNLESS OTHERWISE SHOWN ON PLANS OR NOTED IN THE WSDOT/APWA STANDARD SPECIFICATIONS.
- HANDHOLDS IN ADJUSTMENT SECTION SHALL HAVE 3" MIN CLEARANCE. STEPS IN MANHOLE SHALL HAVE 6" MIN CLEARANCE. HANDHOLDS SHALL BE PLACED IN ALTERNATING GRADE RINGS OR LEVELING BRICK COURSE WITH A MIN OF ONE HAND HOLD BETWEEN THE LAST STEP AND THE TOP OF THE MANHOLE.
- BASE SHALL BE PRECAST WITH AN INTEGRAL RISER UNLESS OTHERWISE APPROVED BY THE ENGINEER. CHANNEL AND BENCH SHALL BE NON-REINFORCED CLASS 3,000 CONCRETE.
- FOR MANHOLES GREATER THAN 15 FT DEEP, OR FOR MANHOLES WITH DIAMETERS GREATER THAN 60" EXTENDING AT LEAST 4 FT INTO THE WET WEATHER WATER TABLE, THE BASE SHALL EXTEND A DISTANCE BEYOND THE OUTER DIAMETER OF THE MANHOLE SUFFICIENT TO COUNTERACT BUOYANCY FORCES. PROVIDE ANTI-FLOTATION CALCULATIONS.
- PRECAST OR CORED CUTOUTS MUST BE CIRCULAR AND SIZED TO ACCOMMODATE APPROVED RUBBER BOOT CONNECTORS FOR THE APPROPRIATE PIPE SIZES. KNOCKOUTS SHALL NOT BE USED UNLESS OTHERWISE APPROVED BY THE ENGINEER. MAX HOLE SIZE SHALL BE 36", 42", AND 48" FOR 4-FT, 4.5-FT, AND 5-FT MANHOLES, RESPECTIVELY. THE MIN DISTANCE BETWEEN HOLE EDGES SHALL BE 8".
- MANHOLE RINGS AND COVERS SHALL MEET THE STRENGTH REQUIREMENTS OF FEDERAL SPECIFICATION A-A-60005. MATING SURFACES SHALL BE FINISHED TO ASSURE NON-ROCKING FIT WITH ANY COVER POSITION.
- BASE REINFORCING STEEL SHALL BE LOCATED IN THE UPPER HALF OF THE BASE, BELOW THE TOP OF THE SLAB AT A DISTANCE OF  $\frac{1}{3}$  TO  $\frac{1}{2}$  THE THICKNESS OF THE SLAB.
- FINAL BACKFILL SHALL CONFORM TO WSDOT SECTION 9-03.9(3) CSBC, UNLESS OTHERWISE APPROVED BY THE ENGINEER.
- MIN SOIL BEARING VALUE SHALL BE 3,000 LB/SF, AND FOR MANHOLE HEIGHTS OVER 12', MIN SOIL BEARING VALUE SHALL BE 3,800 LB/SF.
- JOINTS SHALL BE TONGUE AND GROOVE TYPE CONFORMING TO WSDOT SECTION 7-05.3.

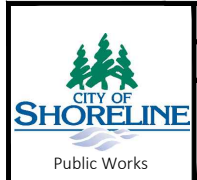

PUBLICATION DATE: <b>03/01/2024</b>	REVISION DATE: <b>09/06/2023</b>
STANDARD DETAIL NUMBER: <b>602</b>	SCALE: <b>NOT TO SCALE</b>

**MANHOLE TYPE II- SANITARY**

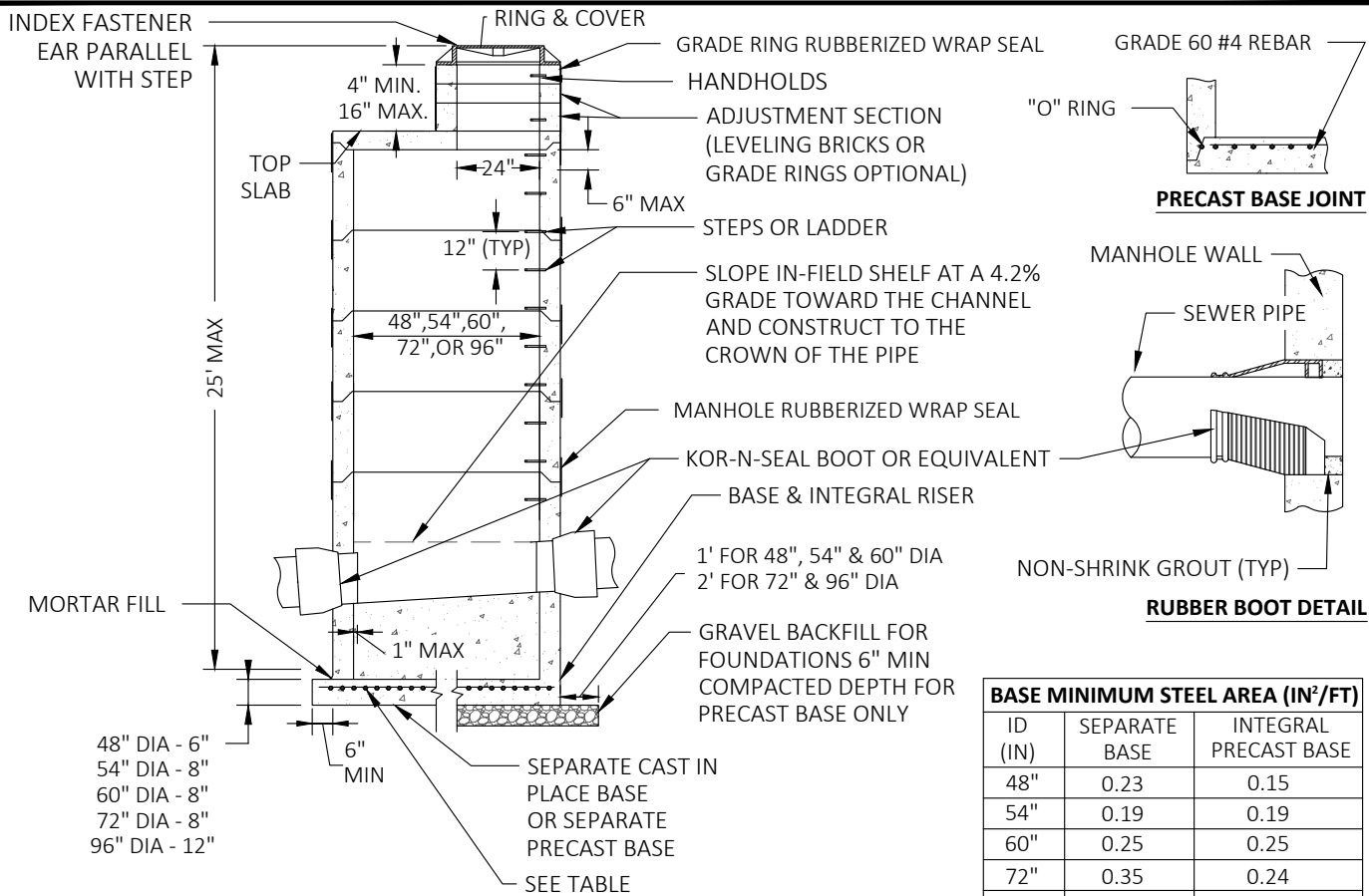

BASE MINIMUM STEEL AREA (IN <sup>2</sup> /FT)		
ID (IN)	SEPARATE BASE	INTEGRAL PRECAST BASE
48"	0.23	0.15
54"	0.19	0.19
60"	0.25	0.25
72"	0.35	0.24
84"-96"	0.25	0.25

**NOTES:**

- MANHOLES SHALL BE CONSTRUCTED IN ACCORDANCE WITH AASHTO M199 UNLESS OTHERWISE SHOWN ON PLANS OR NOTED IN THE WSDOT/APWA STANDARD SPECIFICATIONS.
- HANDHOLDS IN ADJUSTMENT SECTION SHALL HAVE 3" MIN CLEARANCE. STEPS IN MANHOLE SHALL HAVE 6" MIN CLEARANCE. HANDHOLDS SHALL BE PLACED IN ALTERNATING GRADE RINGS OR LEVELING BRICK COURSE WITH A MIN OF ONE HAND HOLD BETWEEN THE LAST STEP AND THE TOP OF THE MANHOLE.
- BASE SHALL BE PRECAST WITH AN INTEGRAL RISER UNLESS OTHERWISE APPROVED BY THE ENGINEER. CHANNEL AND BENCH SHALL BE NON-REINFORCED CLASS 3,000 CONCRETE.
- FOR MANHOLES GREATER THAN 15 FT DEEP, OR FOR MANHOLES WITH DIAMETERS GREATER THAN 60" EXTENDING AT LEAST 4 FT INTO THE WET WEATHER WATER TABLE, THE BASE SHALL EXTEND A DISTANCE BEYOND THE OUTER DIAMETER OF THE MANHOLE SUFFICIENT TO COUNTERACT BUOYANCY FORCES. PROVIDE ANTI-FLOTATION CALCULATIONS.
- PRECAST OR CORED CUTOUTS MUST BE CIRCULAR AND SIZED TO ACCOMMODATE APPROVED RUBBER BOOT CONNECTORS FOR THE APPROPRIATE PIPE SIZES. KNOCKOUTS SHALL NOT BE USED UNLESS OTHERWISE APPROVED BY THE ENGINEER. MAX HOLE SIZE SHALL BE 36", 42", AND 48" FOR 4-FT, 4.5-FT, AND 5-FT MANHOLES, RESPECTIVELY. THE MIN DISTANCE BETWEEN HOLE EDGES SHALL BE 8".
- MANHOLE RINGS AND COVERS SHALL MEET THE STRENGTH REQUIREMENTS OF FEDERAL SPECIFICATION A-A-60005. MATING SURFACES SHALL BE FINISHED TO ASSURE NON-ROCKING FIT WITH ANY COVER POSITION.
- BASE REINFORCING STEEL SHALL BE LOCATED IN THE UPPER HALF OF THE BASE, BELOW THE TOP OF THE SLAB AT A DISTANCE OF  $\frac{1}{3}$  TO  $\frac{1}{2}$  THE THICKNESS OF THE SLAB.
- FINAL BACKFILL SHALL CONFORM TO WSDOT SECTION 9-03.9(3) CSBC, UNLESS OTHERWISE APPROVED BY THE ENGINEER.
- MIN SOIL BEARING VALUE SHALL BE 3,000 LB/SF, AND FOR MANHOLE HEIGHTS OVER 12', MIN SOIL BEARING VALUE SHALL BE 3,800 LB/SF.
- JOINTS SHALL BE TONGUE AND GROOVE TYPE CONFORMING TO WSDOT SECTION 7-05.3.



PUBLICATION DATE: **03/01/2024** REVISION DATE: **09/06/2023**  
 STANDARD DETAIL NUMBER: **603** SCALE: **NOT TO SCALE**

**MANHOLE TYPE III- SANITARY**

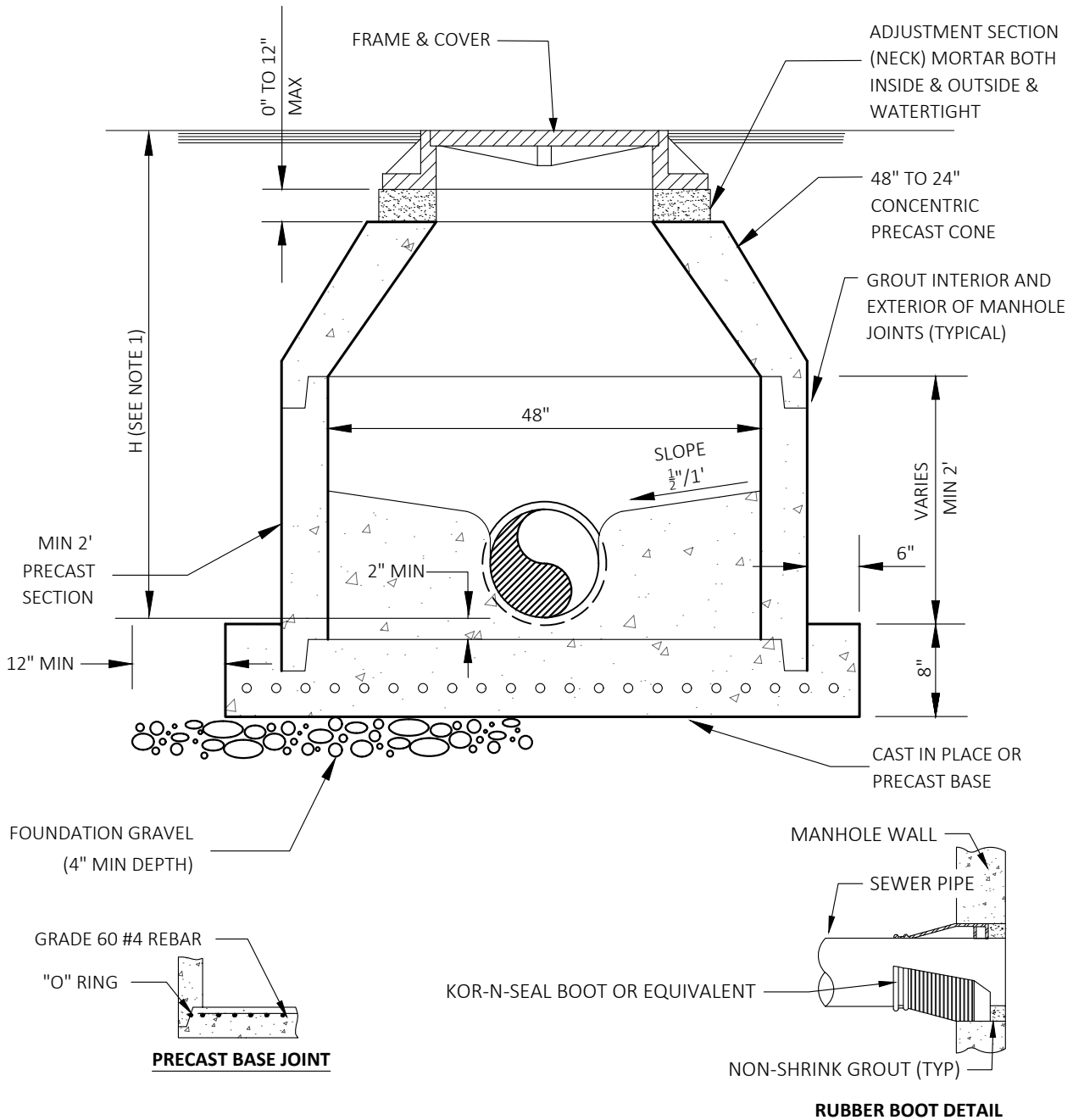

**NOTES:**

1. MANHOLES SHALL BE CONSTRUCTED IN ACCORDANCE WITH AASHTO M199 UNLESS OTHERWISE SHOWN ON PLANS OR NOTED IN THE WSDOT/APWA STANDARD SPECIFICATIONS.
2. MAXIMUM H IS 5 FEET. WHEN H IS LESS THAN 3'-6", USE A CONCENTRIC FLAT TOP SLAB.
3. BASE SHALL BE REINFORCED WITH GRADE 60 #4 REBAR WITH A MINIMUM STEEL AREA OF 0.15 IN<sup>2</sup>/FT FOR AN INTEGRAL BASE, OR 0.23 IN<sup>2</sup>/FT FOR A SEPARATE BASE.
4. MAXIMUM PIPE SIZED SHALL BE 12".
5. PIPE CONNECTIONS SHALL BE MADE WITH A RUBBER BOOK UNLESS OTHERWISE APPROVED BY THE ENGINEER.

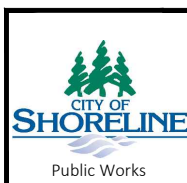

PUBLICATION DATE: <b>03/01/2024</b>	REVISION DATE: <b>09/06/2023</b>
STANDARD DETAIL NUMBER: <b>604</b>	SCALE: <b>NOT TO SCALE</b>

## MANHOLE TYPE IIIA 48 IN-SANITARY

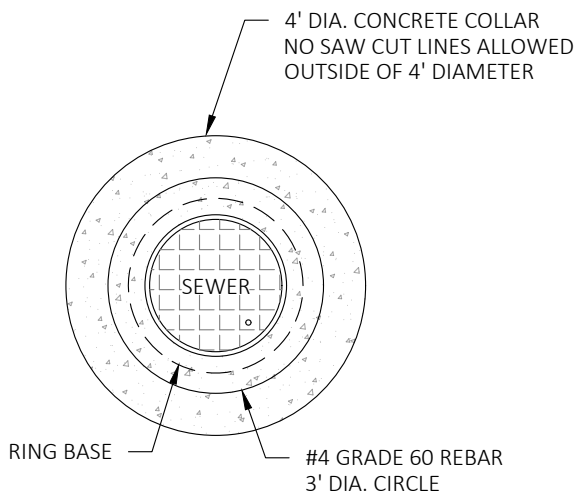

**ROUND CONCRETE COLLAR**

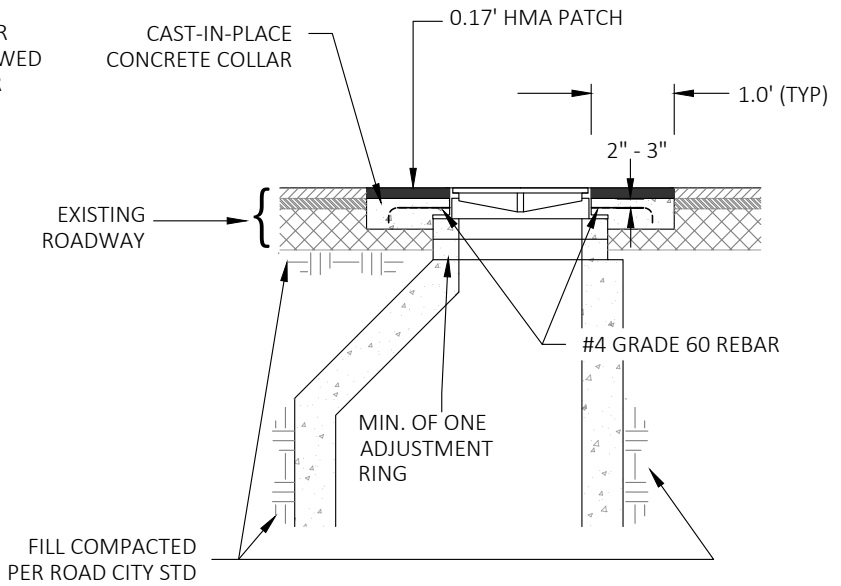

**MANHOLE IN PAVED AREA**

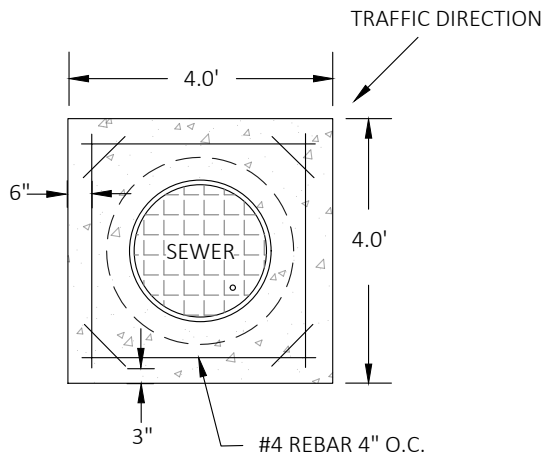

**DIAMOND CONCRETE COLLAR**

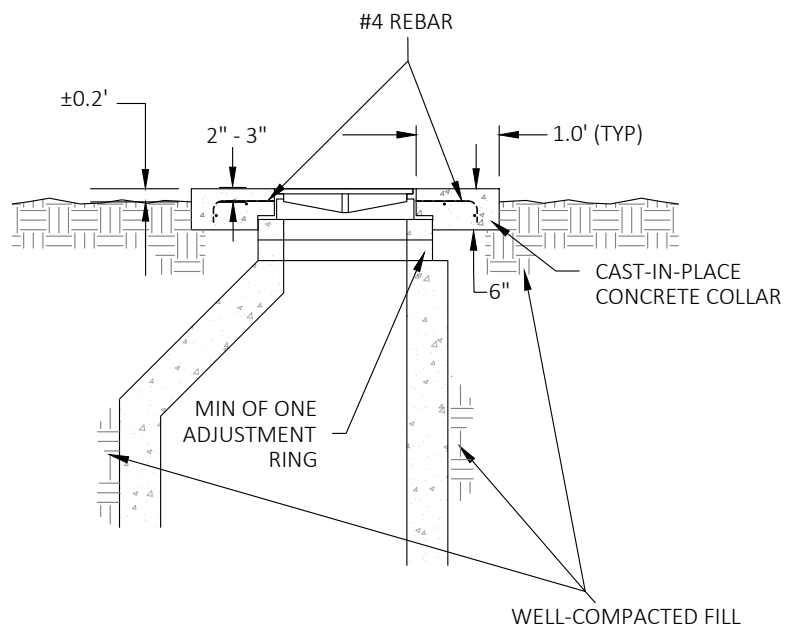

**MANHOLE OUTSIDE PAVED AREA**

**NOTES:**

1. ON MANHOLE OUTSIDE ASPHALT, ADD REINFORCING STEEL AS SHOWN ABOVE. DEFORMED BAR TO MEET ASTM A615 GRADE 60, FY=60,000 P.S.I. CONCRETE COLLAR SHALL BE CLASS 4,000 WITH CLASS 60 REBAR REINFORCEMENT. REBAR PLACEMENT SHALL BE 2" TO 3" FROM THE TOP FACE OF THE SLAB. FOR THE DIAMOND CONCRETE COLLAR, BEND REBAR AS SHOWN IN THE DOTTED LINES IN THE DIAGRAMS.
2. OPENING IN LID FOR USE OF MANHOLE HOOK IS REQUIRED.
3. MANHOLE COVERS SHALL BE BOLT-DOWN LOCKING TYPE.

	PUBLICATION DATE: <b>03/01/2024</b>	REVISION DATE: <b>09/06/2023</b>
	STANDARD DETAIL NUMBER: <b>605</b>	SCALE: <b>NOT TO SCALE</b>
	<b>MANHOLE CONCRETE COLLAR - SANITARY</b>	

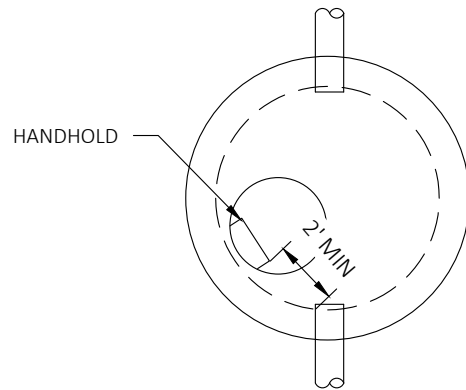
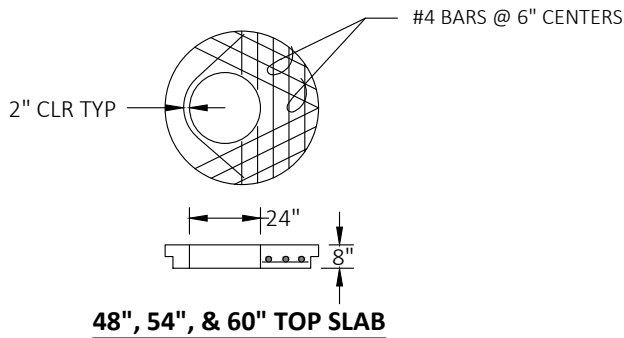

**TYPICAL ORIENTATION FOR ACCESS AND STEPS**

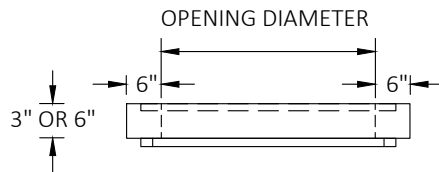
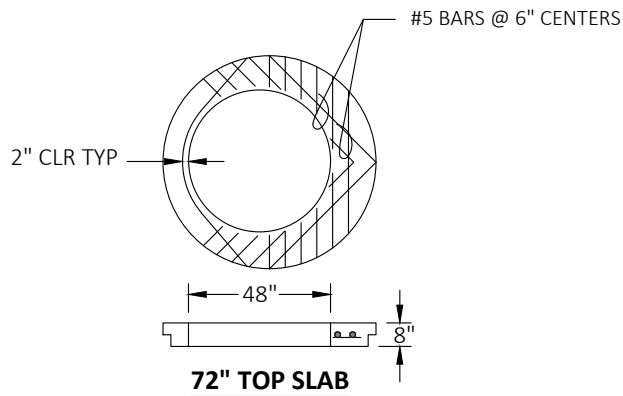

**CONCRETE GRADE RING (TYP)**

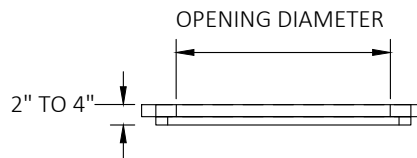
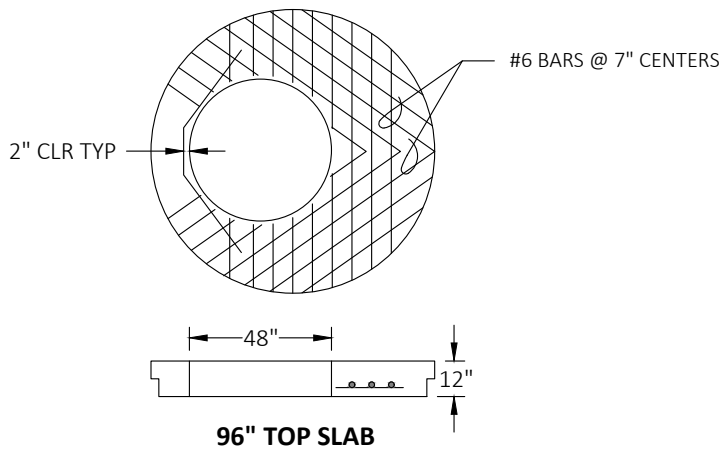

**RISER RING (TYP)**

**NOTES:**

1. SLAB OPENING SHALL BE 24" DIAM. (TYP). 30" AND 36" ACCESS OPENINGS MAY BE APPROVED BY THE ENGINEER.
2. ACCESS HOLE SHALL BE LOCATED ABOVE THE BENCH, NEVER ABOVE THE CHANNEL.
3. STEEP REINFORCEMENT SHALL BE LOCATED IN THE BOTTOM HALF OF THE SLAB AT A DISTANCE FROM THE BOTTOM FACE EQUAL TO ROUGHLY  $\frac{1}{3}$  OF THE SLAB THICKNESS.
4. HANDHOLDS AND STOPS SHALL HAVE "DROP" RUNGS OR PROTUBERANCES TO PREVENT SIDEWAYS SLIP. RISER RINGS SHALL BE CAST IRON UNLESS OTHERWISE SPECIFIED BY THE ENGINEER. PROVIDE ASPHALTIC PAINT OR SIMILAR CORROSION RESISTANT COATING.



PUBLICATION DATE: **03/01/2024** REVISION DATE: **09/06/2023**

STANDARD DETAIL NUMBER: **606** SCALE: **NOT TO SCALE**

**MANHOLE TOP SLAB & RISER  
DETAIL - SANITARY**

\* ALL STEPS & RUNGS 1" DIA GALV REBAR OR COPOLYMER PROPYLENE

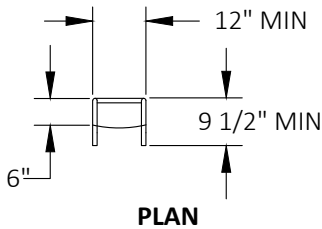
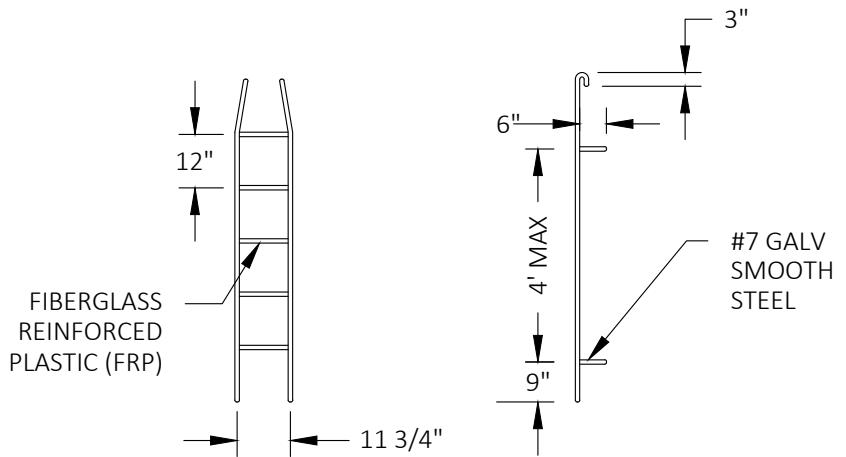
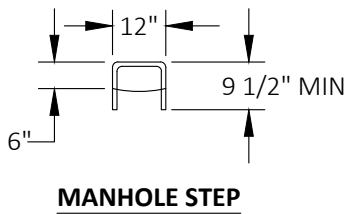
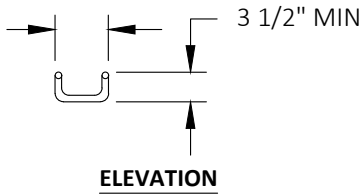
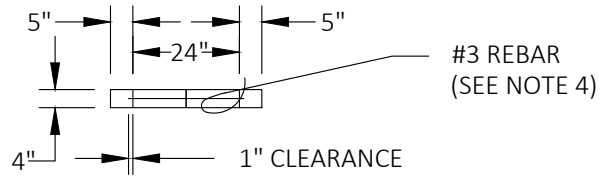
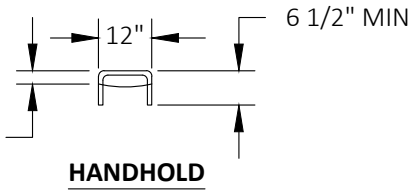

**NOTES:**

1. PROPRIETARY MANHOLE HANDHOLDS AND STEPS ARE ACCEPTABLE, PROVIDED THAT THEY CONFORM TO SEC R, ASTM C478, AASHTO M199 AND MEET ALL WISHA REQUIREMENTS.
2. MANHOLE STEP/HANDHOLD LEGS SHALL BE PARALLEL OR APPROXIMATELY RADIAL AT THE OPTION OF THE MANUFACTURER, EXCEPT THAT ALL STEPS IN ANY MANHOLE SHALL BE SIMILAR. PENETRATION OF OUTER WALL BY A LEG IS PROHIBITED.
3. HANDHOLDS AND STEPS SHALL HAVE "DROP" RUNGS OR PROTUBERANCES TO PREVENT SIDEWAYS SLIP. HANDHOLDS IN ADJUSTMENT SECTION SHALL HAVE 3" MIN CLEARANCE. PLACE IN ALTERNATING GRADE RINGS OR LEVELING BRICK COURSE WITH A MINIMUM OF ONE HANDHOLD BETWEEN THE TOPMOST STEP AND THE TOP OF THE MANHOLE.
4. LADDERS OR STEPS SHALL EXTEND TO WITHIN 16" OF BOTTOM OF MANHOLE. STEPS SHALL HAVE 6" MIN CLEARANCE.
5. HANGING LADDERS SHALL BE PERMANENTLY FASTENED AT TOP BY HANGING ON STEP OR BY BOLTING OR EMBEDDING IN CONCRETE. EACH SHALL BE EMBEDDED AT BOTTOM IN BASE.
6. ADDITIONAL SAFETY FEATURES MAY BE REQUIRED.

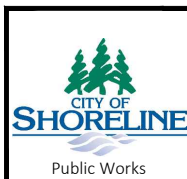

PUBLICATION DATE: **03/01/2024** REVISION DATE: **09/06/2023**

STANDARD DETAIL NUMBER: **607** SCALE: **NOT TO SCALE**

**MANHOLE LADDER & HANDHOLD  
DETAIL - SANITARY**

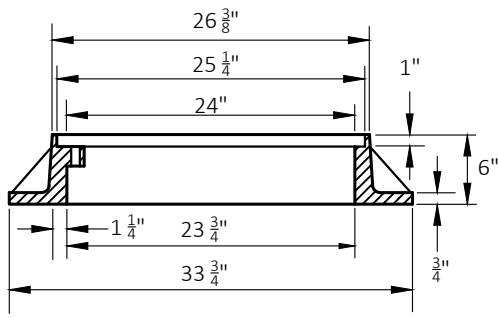
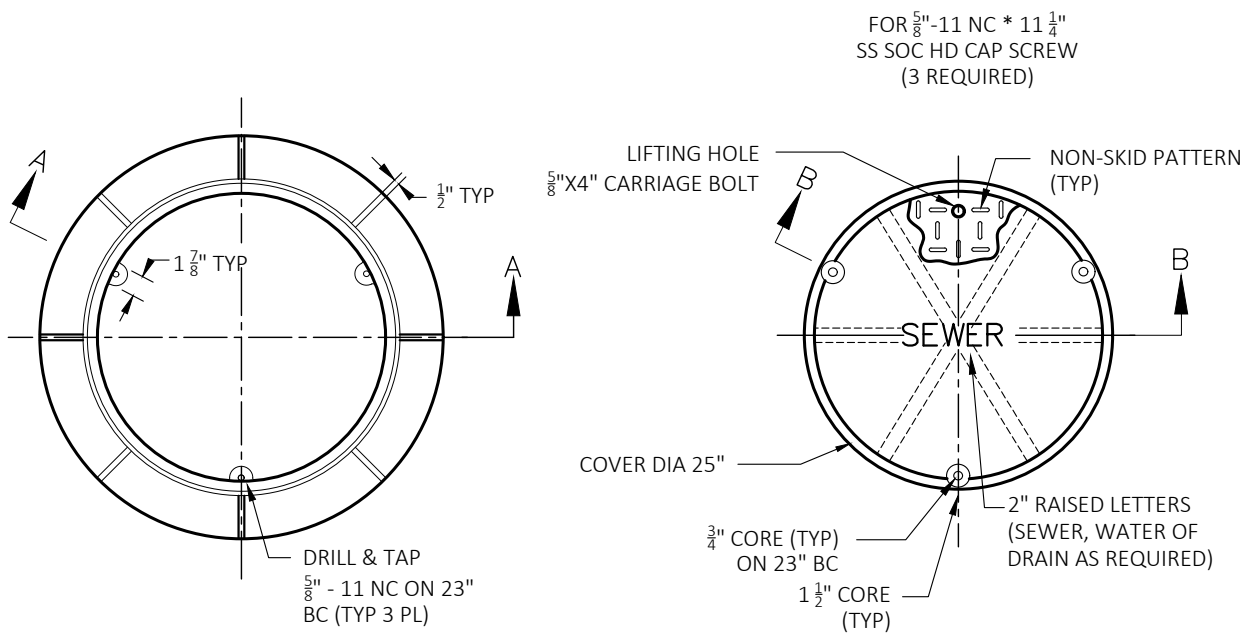

**SECTION A-A**

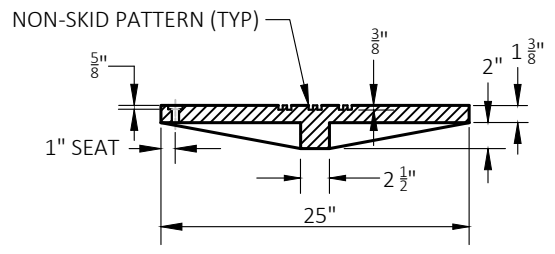

**SECTION B-B**

**NOTES:**

1. DRILL LUG HOLES FULL DEPTH.
2. BOLT COVER TO LUGS IN RING.
3. PROVIDE  $\frac{7}{8}$ "  $\varnothing$  LIFTING HOLE AND LIFT HOLE BOLT/NUT (5/8"x4" CARRIAGE BOLT). DEFORM THREADS TO PREVENT LOSS OF NUT.
4. DUCTILE IRON COVER, CAST IRON FRAME.
5. SEE SPECIFICATION O2605 FOR ADDITIONAL REQUIREMENTS.
6. FRAME AND COVER PER APWA.
7. EJCO MODEL NUMBER 3715 ZPT OR EQUAL.

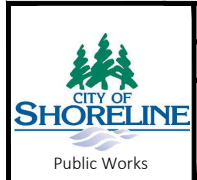

PUBLICATION DATE: <b>03/01/2024</b>	REVISION DATE: <b>09/06/2023</b>
STANDARD DETAIL NUMBER: <b>608</b>	SCALE: <b>NOT TO SCALE</b>

**MANHOLE FRAME & COVER -  
SANITARY**



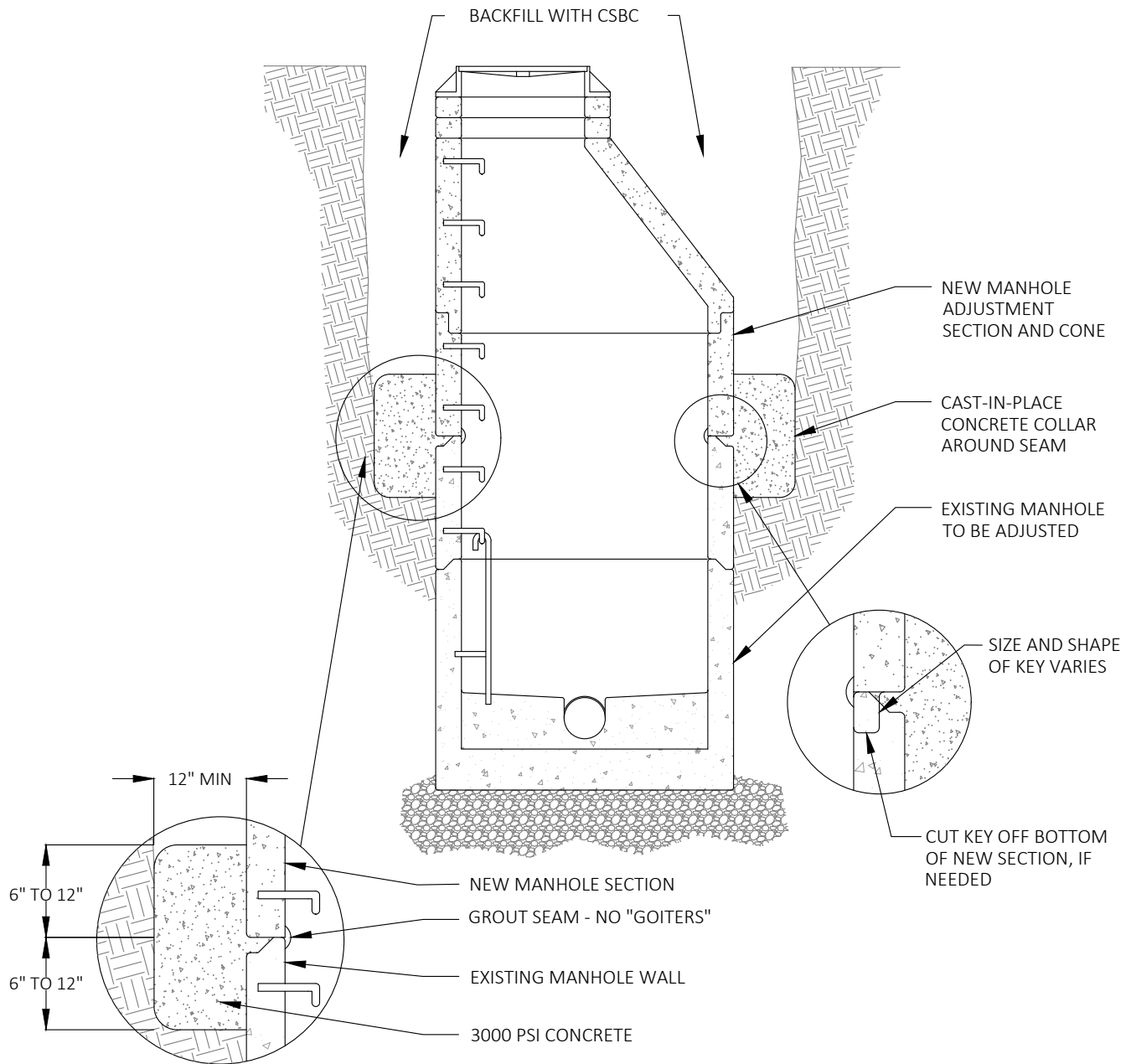

**NOTES:**

1. MANHOLE SHALL CONFORM TO THE APPLICABLE CITY STANDARD DETAIL FOR SANITARY SEWER MANHOLES.
2. WHERE DEPTH OF MANHOLE NECK EXCEEDS 24", ADJUST MANHOLE TO GRADE BY INSTALLING NEW MANHOLE BARREL SECTION AND CONE ON EXISTING MANHOLE BARREL.
3. WHERE KEY SECTIONS OF NEW AND EXISTING MANHOLES ARE NOT COMPATIBLE, CUT KEY OFF BOTTOM OF NEW SECTION AND PROVIDE A CAST-IN-PLACE CONCRETE COLLAR AROUND MANHOLE PERMITER. CAST COLLAR WITH 3000 PSI CONCRETE.
4. UPWARD ADJUSTMENT OF EXISTING MANHOLES MUST BE DONE WITH ALL NEW PARTS, AS NECESSARY, TO ENSURE ONLY ONE INCOMPATIBLE SEAM.
5. GROUT ALL JOINTS INSIDE, OUTSIDE, AND IN BETWEEN TO ACHIEVE WATERTIGHT CONSTRUCTION. FINISH AND SMOOTH THE INSIDE OF THE STRUCTURE. USE NON-SHRINK GROUT ONLY.

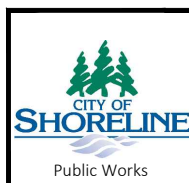

PUBLICATION DATE: **03/01/2024** REVISION DATE: **09/06/2023**

STANDARD DETAIL NUMBER: **609** SCALE: **NOT TO SCALE**

**MANHOLE ADJUST DETAIL-  
SANITARY**

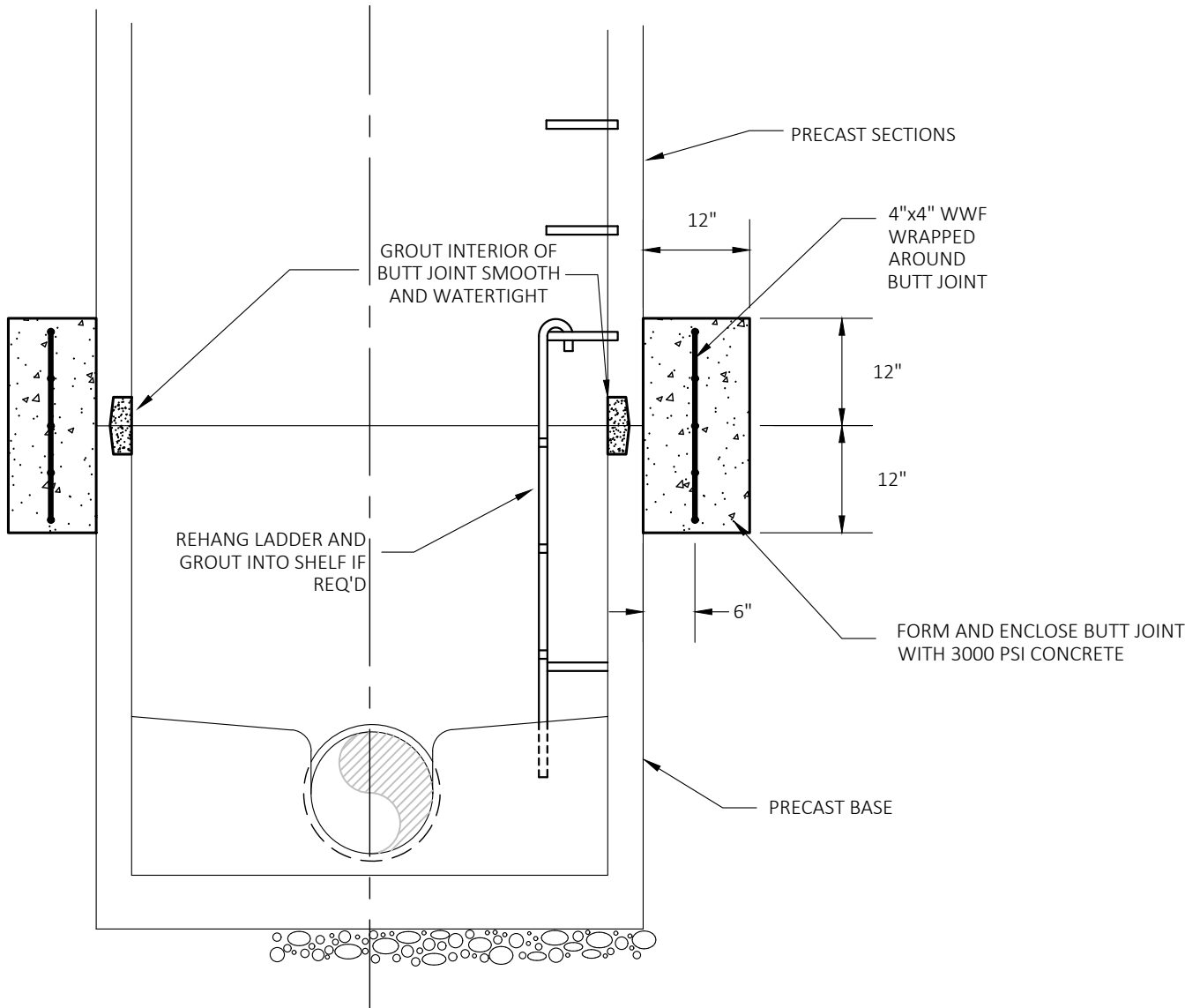

**NOTES:**

1. REQUIRES SPECIAL PERMISSION AND INSPECTION BY THE CITY.
2. NO WALL PENETRATIONS ALLOWED IN THE BUTT JOINT AREA.
3. PRECAST SECTION BUTT JOINT AREA MUST BE CLEAN AND UNBROKEN.



PUBLICATION DATE: <b>03/01/2024</b>	REVISION DATE: <b>09/06/2023</b>
STANDARD DETAIL NUMBER: <b>610</b>	SCALE: <b>NOT TO SCALE</b>

**MANHOLE BUTT JOINT**

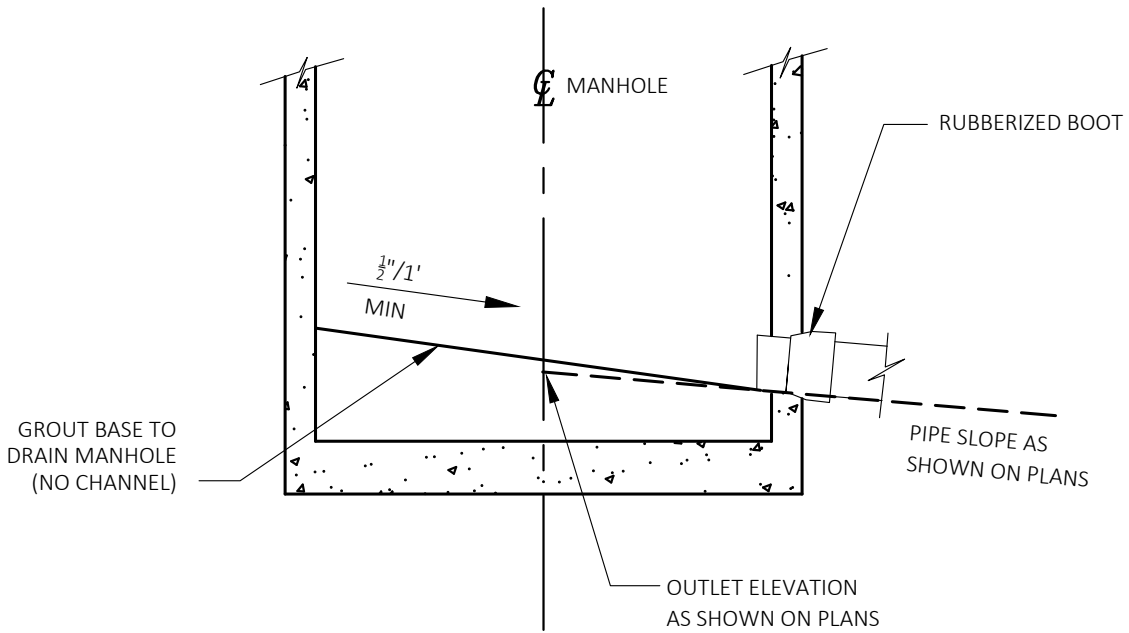

**TERMINAL MANHOLE**

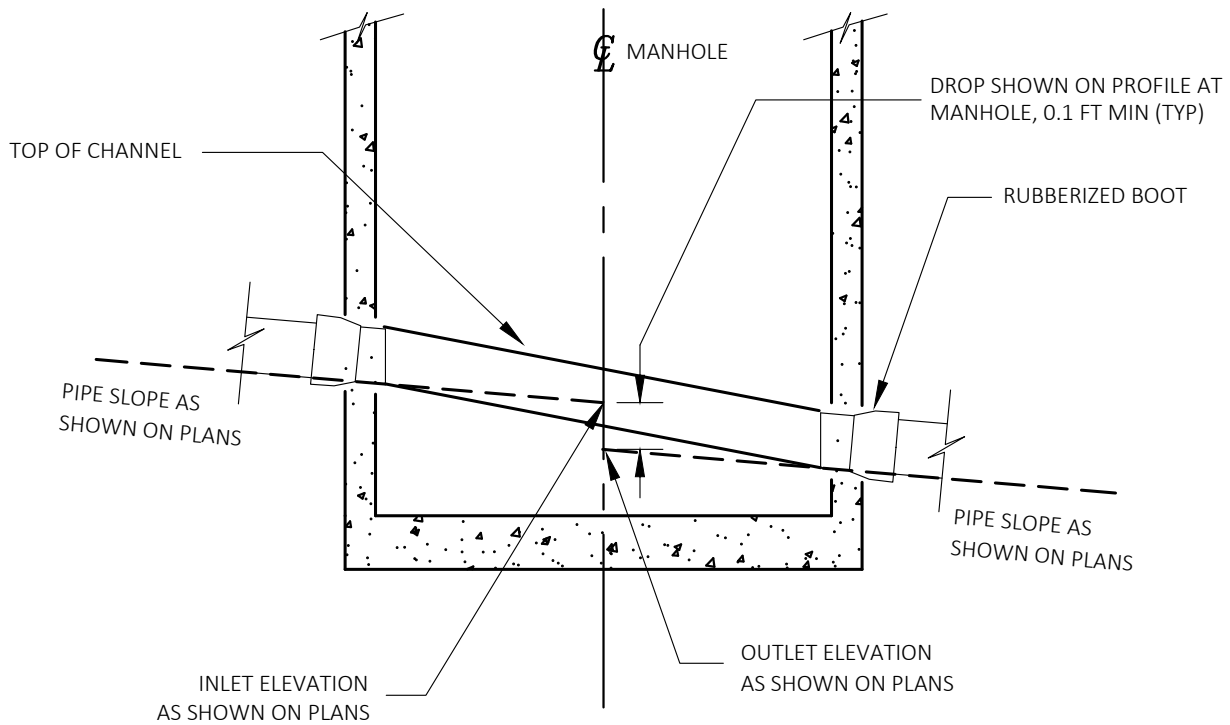

**MAIN-LINE MANHOLE**

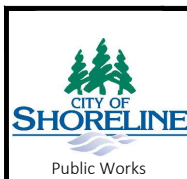

PUBLICATION DATE: **03/01/2024** REVISION DATE: **09/06/2023**

STANDARD DETAIL NUMBER: **611** SCALE: **NOT TO SCALE**

**MANHOLE CHANNELING DETAIL-  
SANITARY**

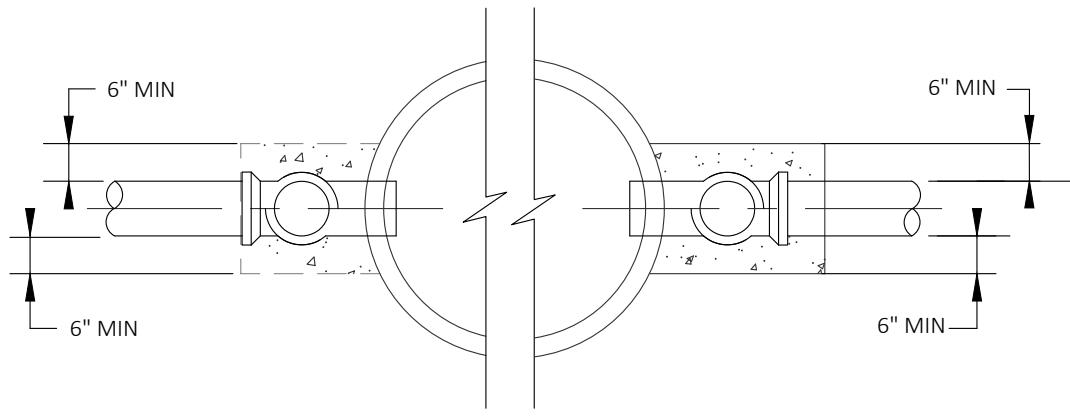

**PLAN**

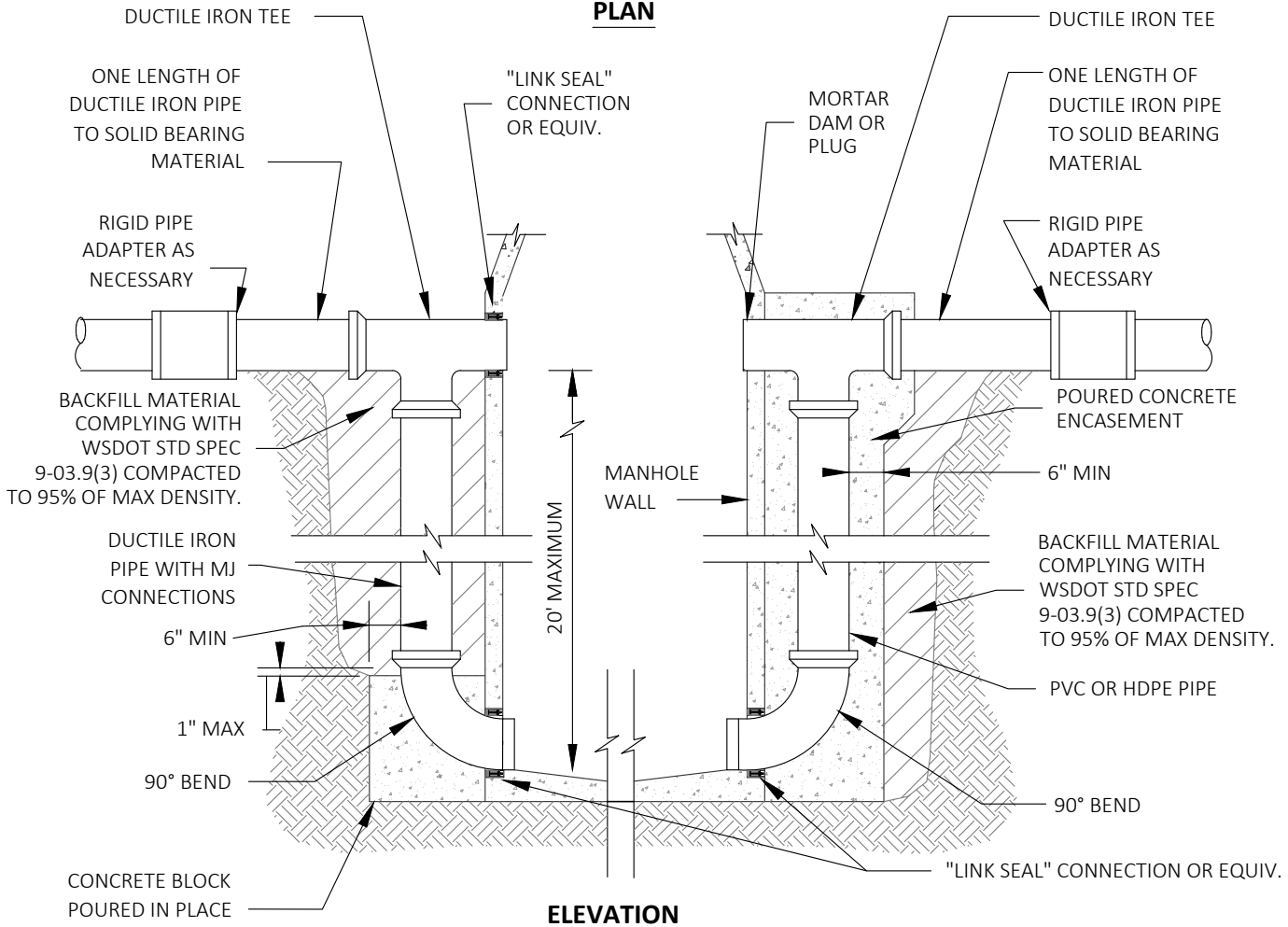

**DUCTILE IRON ALTERNATIVE**

**CONCRETE ENCASED ALTERNATIVE**

**NOTES:**

1. USE LINK SEAL MANHOLE CONNECTIONS (OR EQUIVALENT) AS SHOWN UNLESS OTHERWISE APPROVED BY THE ENGINEER.
2. POURED CONCRETE SHALL BE NON-REINFORCED CLASS 4000 CONCRETE, FIELD-TESTED FOR COMPRESSIVE STRENGTH ACCORDING TO ASTM C 31 AND ASTM C 39.



PUBLICATION DATE: <b>03/01/2024</b>	REVISION DATE: <b>10/06/2023</b>
STANDARD DETAIL NUMBER: <b>612</b>	SCALE: <b>NOT TO SCALE</b>

**MANHOLE OUTSIDE DROP CONNECTION- SANITARY**

ALIGN PIPE TO FLOW LINE

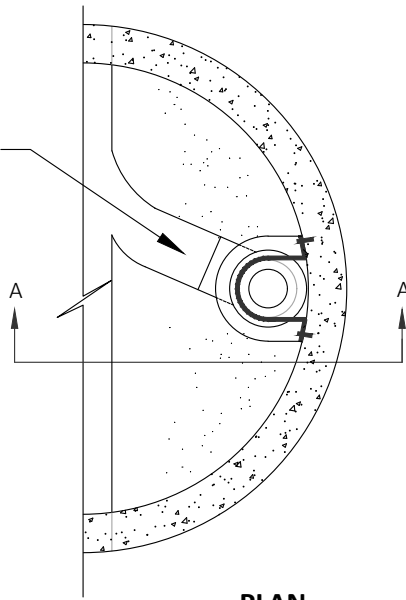

**PLAN**

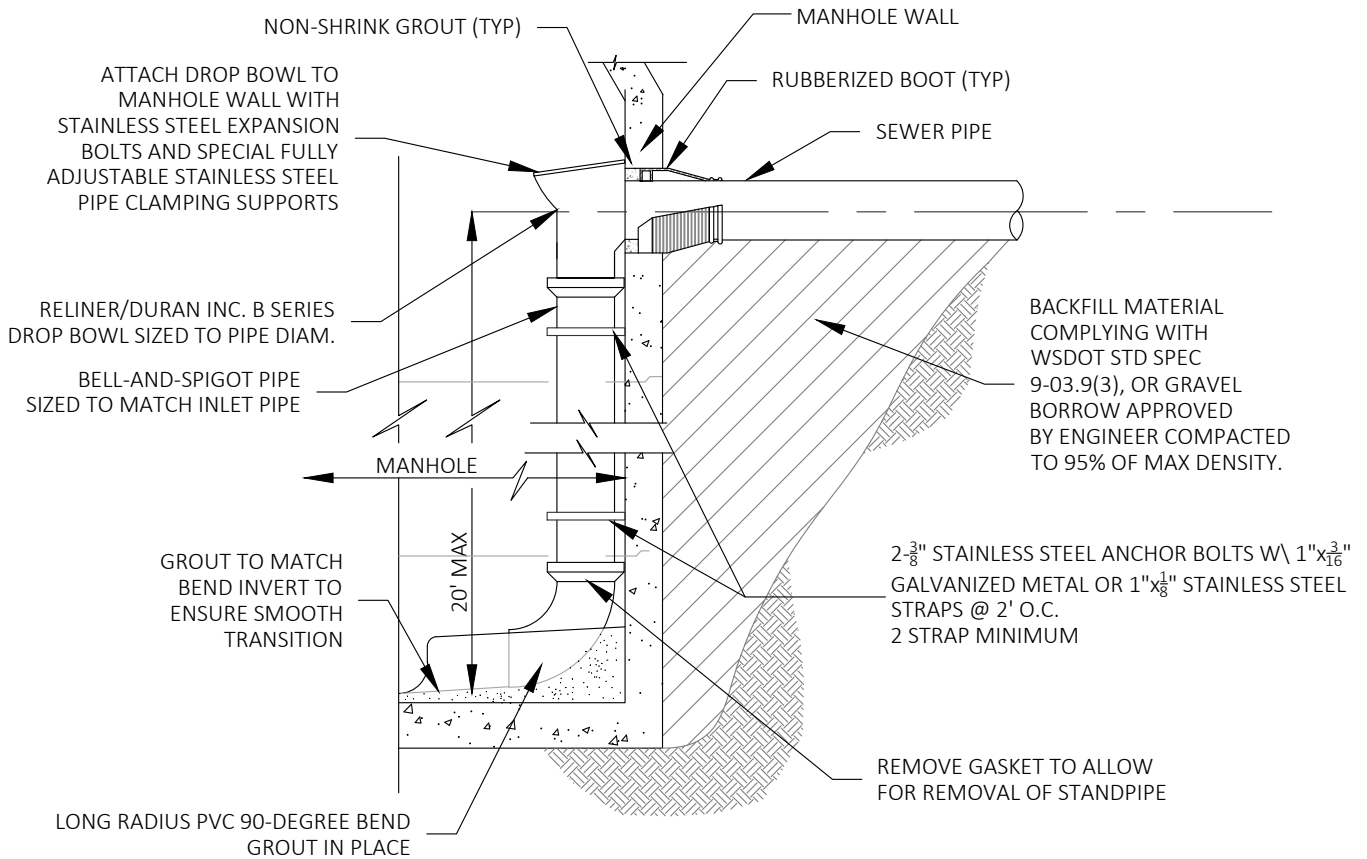

**ELEVATION**

SECTION A-A

NOTE: THIS ASSEMBLY TO BE USED ONLY WITH SPECIFIC AUTHORIZATION

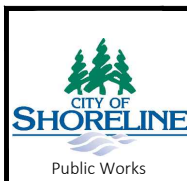

PUBLICATION DATE: **03/01/2024** REVISION DATE: **09/06/2023**

STANDARD DETAIL NUMBER: **613** SCALE: **NOT TO SCALE**

**MANHOLE INSIDE DROP CONNECTION - SANITARY**

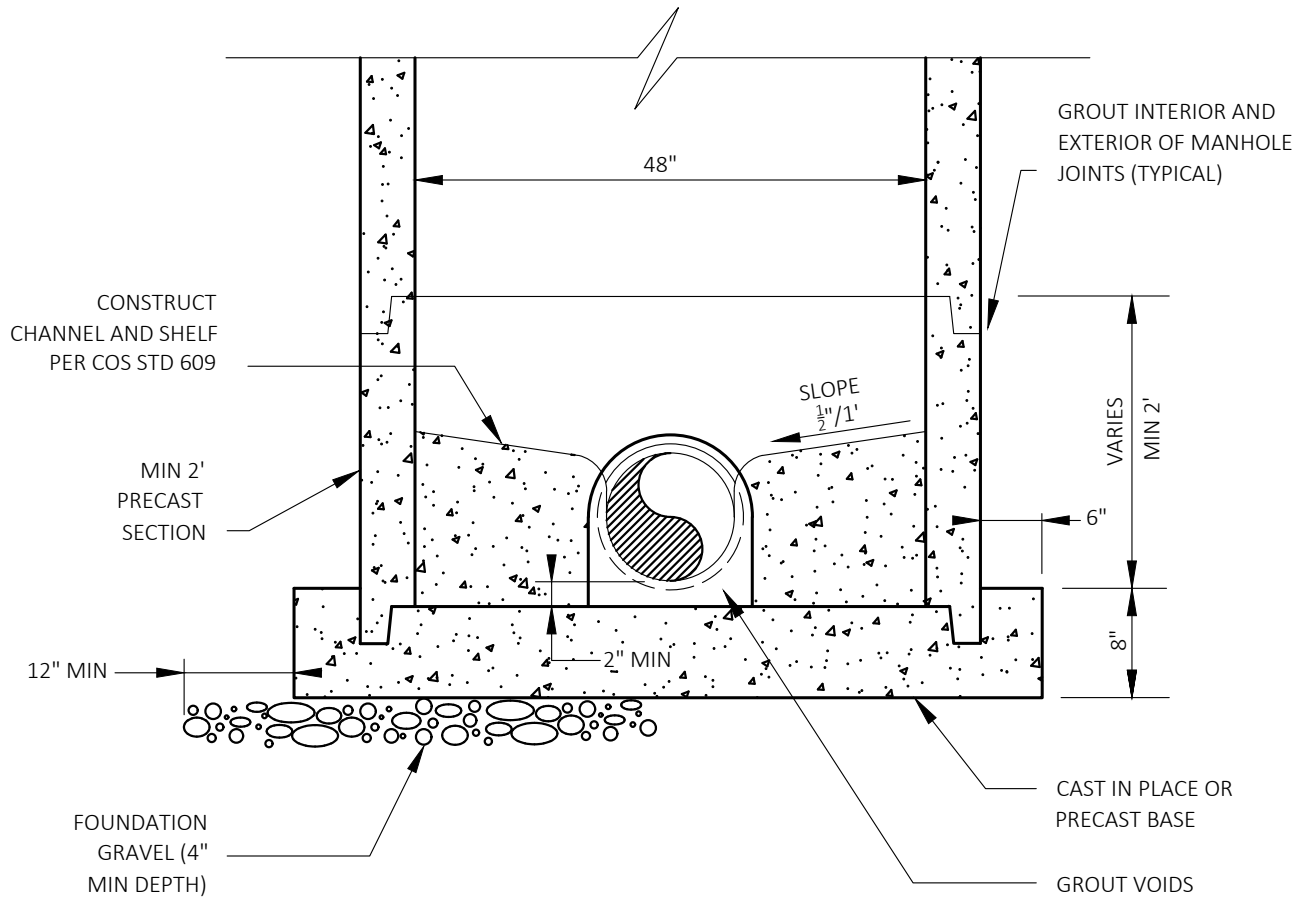

BASE MINIMUM STEEL AREA (IN <sup>2</sup> /FT)	
ID (IN)	SEPARATE BASE
48"	0.23
54"	0.19
60"	0.25
72"	0.35
84"-96"	0.25

**NOTES:**

1. SEWER MAIN TEO REMAIN IN SERVICE THROUGHOUT CONSTRUCTION PERIOD.
2. DO NOT CUT INTO SEWER MAIN UNTIL REMAINDER OF EXTENSION IS READY FOR SERVICE AND AUTHORIZED BY THE CITY.
3. SADDLED SEWER MAIN TO REMAIN ISOLATED UNTIL CITY APPROVES CHANNELING.

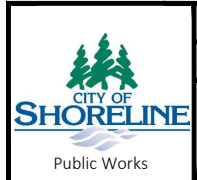

PUBLICATION DATE: **03/01/2024** REVISION DATE: **09/06/2023**  
 STANDARD DETAIL NUMBER: **614** SCALE: **NOT TO SCALE**

**SADDLE TYPE 48 IN DROP IN  
 MANHOLE - SANITARY**

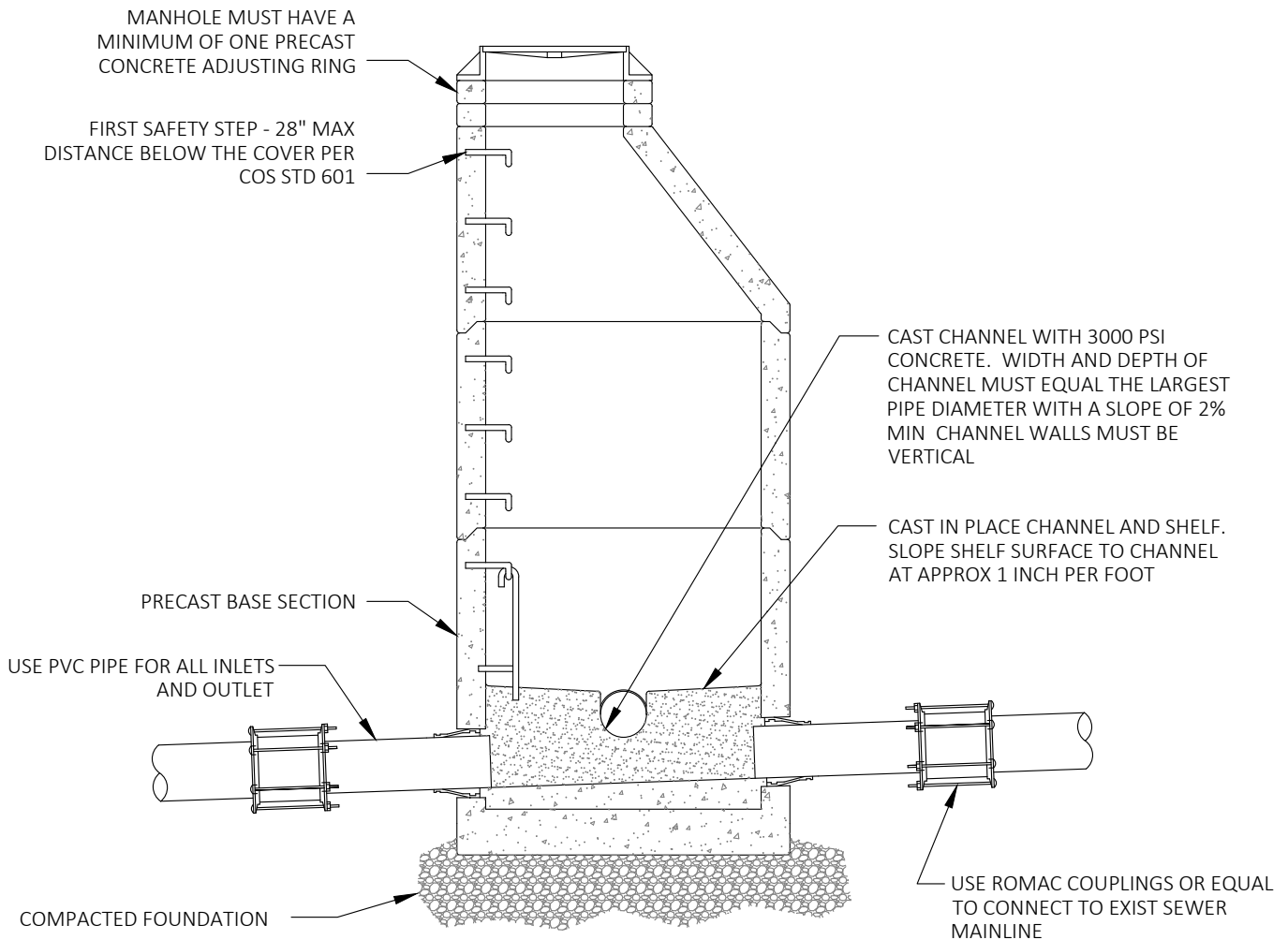

**NOTES:**

1. MANHOLE SHALL CONFORM TO THE GENERAL NOTES AND ALL APPLICABLE REQUIREMENTS OF COS STD 601.
2. THE ENTRY ANGLE OF THE NEW SEWER CONNECTION, RELATIVE TO THE EXISTING SEWER MAIN INLET, SHALL BE 90° OR LESS.
3. IF NEW SEWER CONNECTION IS A MAINLINE, THE INVERT OF THE NEW PIPE SHALL BE SET AT THE SPRINGLINE OF THE EXISTING MAINLINE.
4. IF NEW SEWER CONNECTION IS A SIDE SEWER, THE INVERT OF THE NEW PIPE SHALL BE SET AT OR ABOVE THE CROWN OF THE EXISTING MAINLINE. NEW CONNECTION NOT TO EXCEED 18" ABOVE THE MAINLINE INVERT.
5. PVC PIPE CONNECTION TO MANHOLE: KOR-N-SEAL OR EQUAL FOR CORE-DRILLED SECTIONS, OR SAND COLLAR FOR SECTIONS WITH KNOCKOUTS.
6. CONNECT NEW PVC PIPE TO EXISTING SEWER MAINLINE WITH ROMAC COUPLING OR EQUAL..
7. GROUT ALL JOINTS INSIDE, OUTSIDE AND IN BETWEEN TO ACHIEVE WATERTIGHT CONSTRUCTION. FINISH SMOOTH THE INSIDE OF STRUCTURE. USE NON-SHRINK GROUT ONLY.

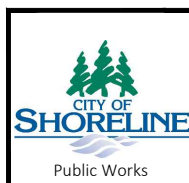

PUBLICATION DATE: **03/01/2024** REVISION DATE: **09/06/2023**

STANDARD DETAIL NUMBER: **615** SCALE: **NOT TO SCALE**

**MANHOLE CUT IN MAIN SECTION -  
SANITARY**

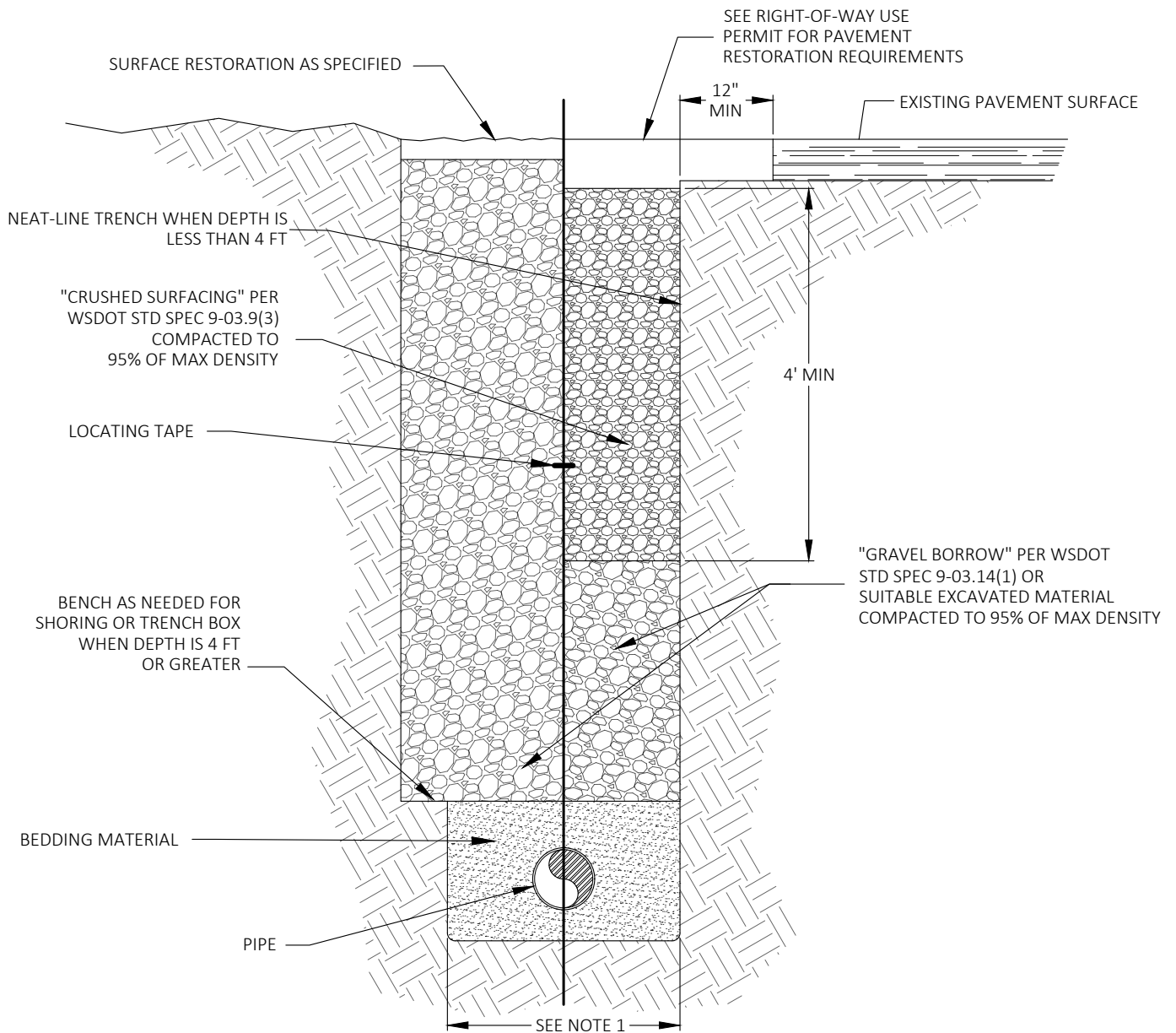

**UNPAVED AREAS**

**PAVED AREAS**

**NOTES:**

1. FOR PIPES WITH NOMINAL DIAMETERS 15 INCHES AND UNDER, MAX TRENCH WIDTH AT THE CROWN ELEVATION SHALL BE THE PIPE O.D. PLUS 30 INCHES. FOR PIPES WITH NOMINAL DIAMETERS GREATER THAN 15 INCHES, MAXIMUM TRENCH WIDTH AT PIPE CROWN ELEVATION SHALL BE PIPE O.D. PLUS 16 INCHES.
2. EXCAVATIONS OVER 4' DEEP SHALL COMPLY WITH THE SAFETY STANDARD DESCRIBED IN CHAPTER 296-155 - PART N OF THE WAC.
3. REFER TO WSDOT STANDARD SPEC SECTION 7-08.3(3) AND THE CITY OF SHORELINE SPECIAL PROVISIONS FOR BEDDING, BACKFILLING, AND COMPACTION REQUIREMENTS.
4. TRACER WIRES SHALL BE INSTALLED ON ALL FORCE MAIN ALIGNMENTS.
5. LOCATING TAPE SHALL BE PLACED HALF THE DISTANCE BETWEEN THE GROUND SURFACE AND PIPE CROWN. TAPE SHALL BE LABELED "SEWER."

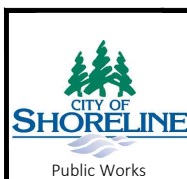

PUBLICATION DATE: <b>03/01/2024</b>	REVISION DATE: <b>09/06/2023</b>
STANDARD DETAIL NUMBER: <b>616</b>	SCALE: <b>NOT TO SCALE</b>

**TYPICAL TRENCH DETAIL - SANITARY**



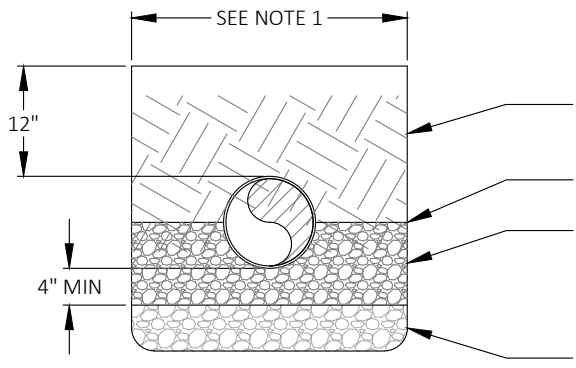

### **RIGID PIPE BEDDING**

COMPACTED BACKFILL (COMPACTED DENSITY PERCENTAGE PER COS STD 614)

SPRING LINE

COMPACTED BEDDING GRAVEL PER SECTION 9-03.12(3), "GRAVEL BACKFILL FOR PIPE ZONE BEDDING", OF THE WSDOT STANDARD SPECIFICATION, OR OTHER MATERIAL IF SPECIFIED. COMPACTION IN 6" LIFTS

FOUNDATION OF GRAVEL, IF REQUIRED (SEE NOTE 2)

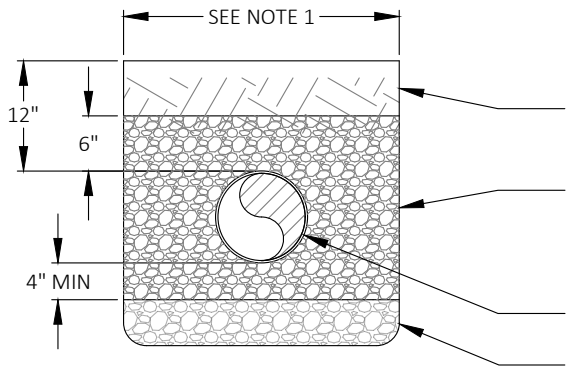

### **FLEXIBLE PIPE BEDDING**

COMPACTED BACKFILL (COMPACTED DENSITY PERCENTAGE PER COS STD 614)

COMPACTED BEDDING GRAVEL PER SECTION 9-03.12(3), "GRAVEL BACKFILL FOR PIPE ZONE BEDDING", OF THE WSDOT STANDARD SPECIFICATION, OR OTHER MATERIAL IF SPECIFIED. COMPACTION IN 6" LIFTS

PIPE

FOUNDATION OF GRAVEL, IF REQUIRED (SEE NOTE 2)

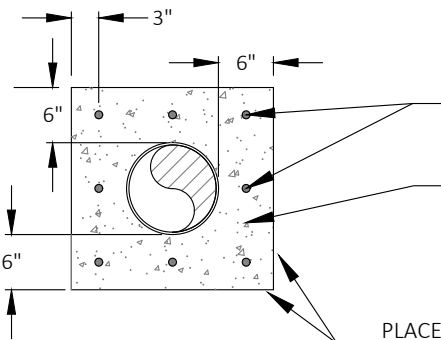

### **CONCRETE ENCASEMENT**

#5 GRADE 60 REBAR PARALLEL TO PIPE  
8 PLACED AS SHOWN, 3" CLEARANCE FROM  
CONCRETE EDGE

COMMERCIAL GRADE CONCRETE  
SEE NOTE 3

PLACE CONCRETE AGAINST EITHER  
SOLID FORMWORK OR UNDISTURBED EARTH

#### **NOTES:**

1. FOR PIPES WITH NOMINAL DIAMETERS 15 INCHES AND UNDER, MAXIMUM TRENCH WIDTH AT THE CROWN ELEVATION SHALL BE THE PIPE O.D. PLUS 30 INCHES. FOR PIPES WITH NOMINAL DIAMETERS GREATER THAN 15 INCHES, MAXIMUM TRENCH WIDTH AT THE CROWN ELEVATION SHALL BE PIPE O.D. PLUS 16 INCHES.
2. EXCAVATE UNSTABLE MATERIAL DOWN TO FIRM SOIL AND REPLACE WITH FOUNDATION GRAVEL PER SECTION 9-03.9(1), "BALLAST", OF THE WSDOT STANDARD SPECIFICATIONS.
3. THE CONTRACTOR SHALL BE RESPONSIBLE FOR ANCHORING PIPE TO PREVENT FLOTATION DURING CONCRETE PLACEMENT.
4. COMPACTED CRUSHED SURFACING PER SECTION 9-03.9(3), "CRUSHED SURFACING", OF THE WSDOT STANDARD SPECIFICATIONS CAN ALSO BE USED AS BEDDING GRAVEL.



PUBLICATION DATE: **03/01/2024** REVISION DATE: **09/06/2023**

STANDARD DETAIL NUMBER: **617** SCALE: **NOT TO SCALE**

## **PIPE ZONE BEDDING DETAIL - SANITARY**

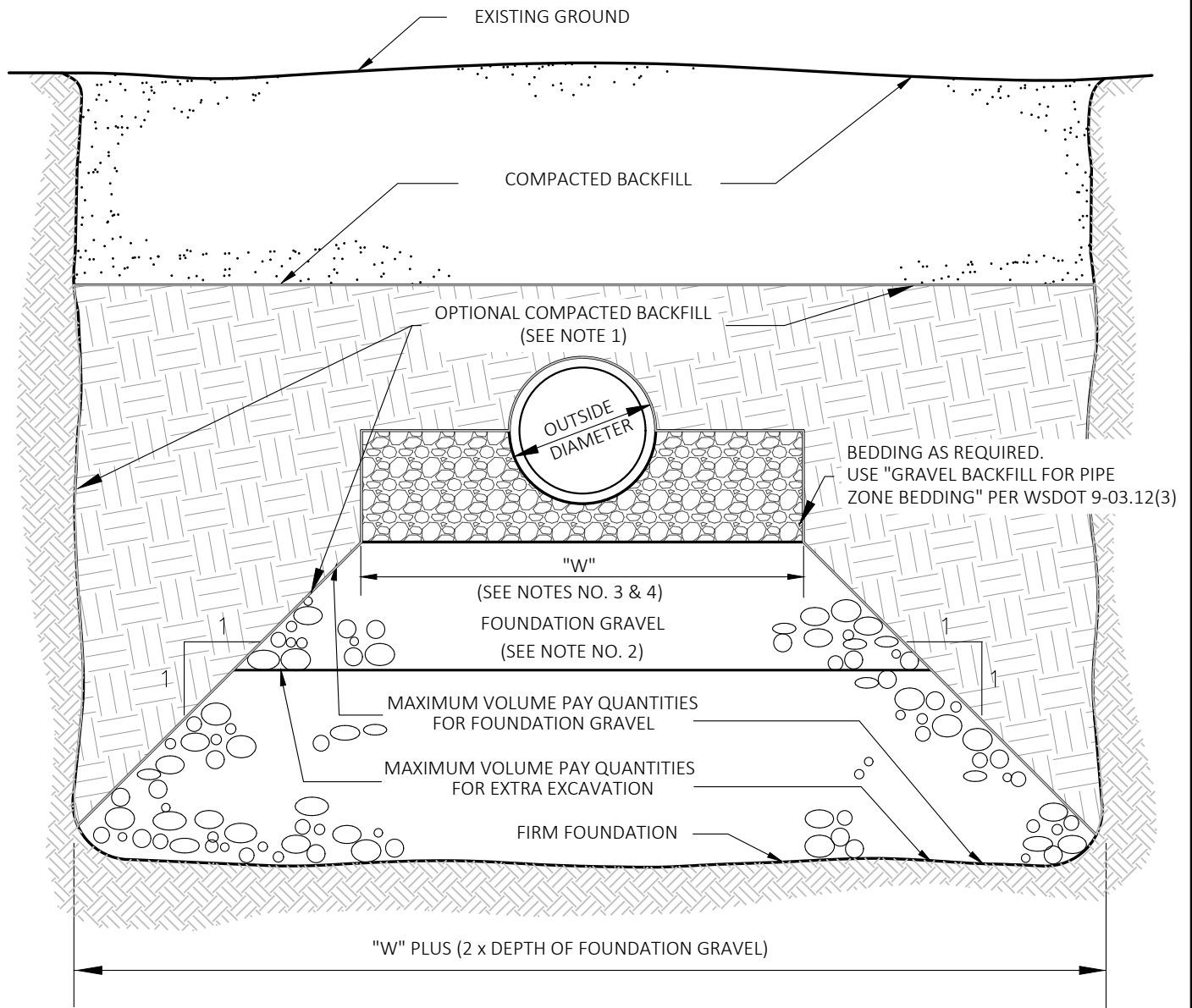

**NOTES:**

1. FOUNDATION GRAVEL OR GRAVEL BEDDING MAY BE SUBSTITUTED AT NO ADDITIONAL COST TO THE OWNER.
2. REMOVE UNSUITABLE MATERIAL TO FIRM FOUNDATION AND REPLACE WITH FOUNDATION GRAVEL WHERE REQUIRED.
3. "W"=40" FOR RIGID PIPE 15" OR LESS IN DIAMETER, "W"=1.5 INTERNAL DIAMETERS PLUS 18" FOR RIGID PIPE 15" OR LARGER IN DIAMETER.
4. "W"=6 PIPE DIAMETERS FOR FLEXIBLE PIPE.
5. TICKETS NOT REQUIRED, QUANTITIES TO BE COMPUTER TO NEAT LINES SHOWN.

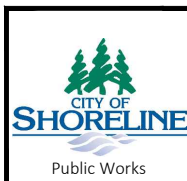

PUBLICATION DATE: <b>03/01/2024</b>	REVISION DATE: <b>09/06/2023</b>
STANDARD DETAIL NUMBER: <b>618</b>	SCALE: <b>NOT TO SCALE</b>
<b>FOUNDATION GRAVEL TO REPLACE UNSUITABLE MATERIAL</b>	

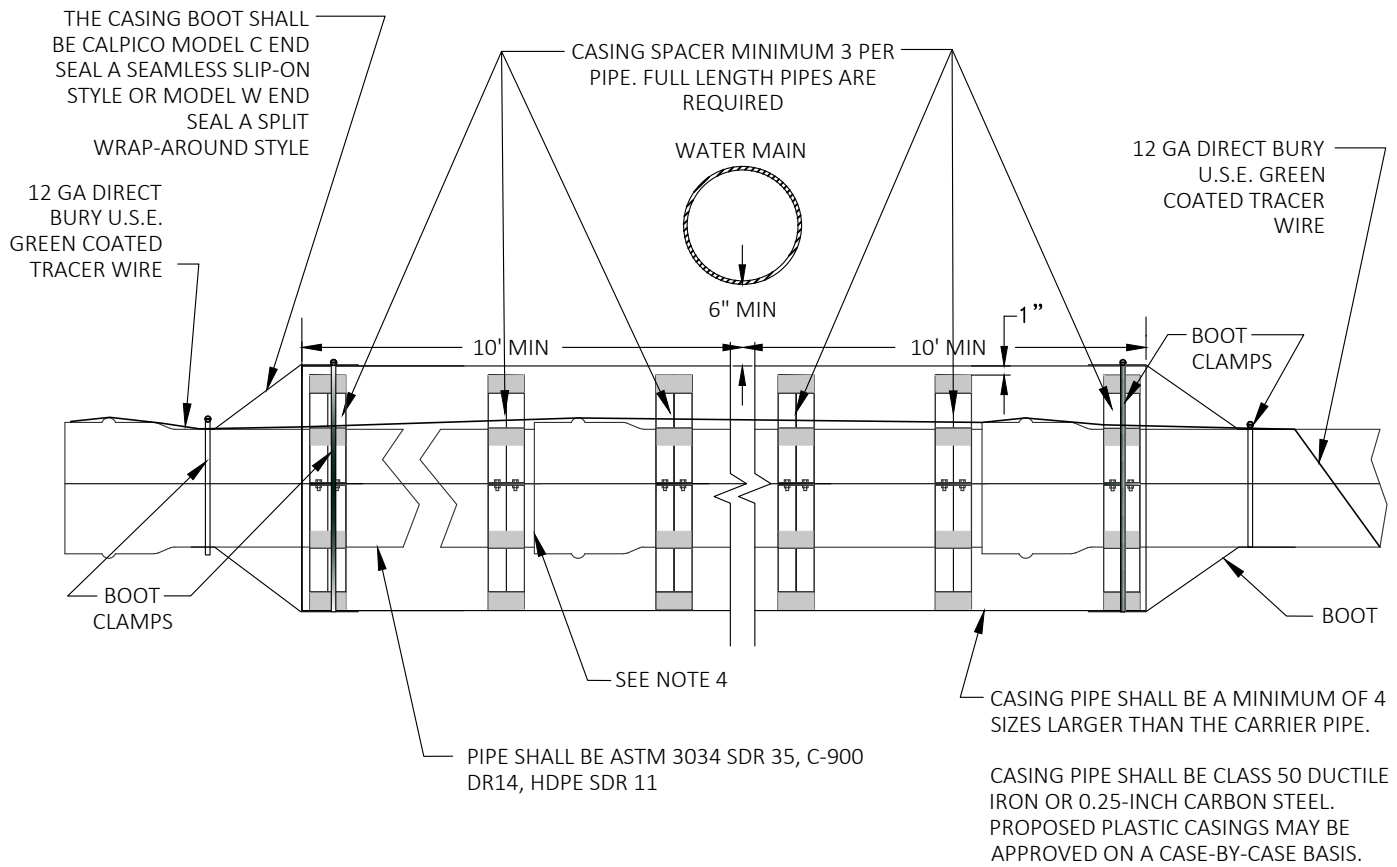

**NOTES:**

1. MANUFACTURED CASING SPACERS ARE REQUIRED AND SHALL BE UNI-FLANGE OR CALPICO INC. PRODUCTS OR AS APPROVED BY THE CITY OF SHORELINE.
2. THE PIPE LENGTHS SHALL BE 20' WITH A MINIMUM OF 3 CASING SPACERS PER PIPE.
3. THERE SHALL BE NO MORE THAN 1" OF CLEARANCE BETWEEN THE TOP OF THE SPACER TO THE TOP OF THE CASING.
4. ALL JOINTS FOR THE PIPE BEING INSTALLED SHALL BE LOCKING GASKET RESTRAINED JOINTS.
5. PROVIDE CATHODIC PROTECTION/CORROSION PROTECTION FOR DUCTILE IRON OR CARBON STEEL PIPES.

 CITY OF SHORELINE Public Works	PUBLICATION DATE: <b>03/01/2024</b>	REVISION DATE: <b>09/06/2023</b>
	STANDARD DETAIL NUMBER: <b>619</b>	SCALE: <b>NOT TO SCALE</b>
<b>SPLIT CASING DETAIL - SANITARY</b>		

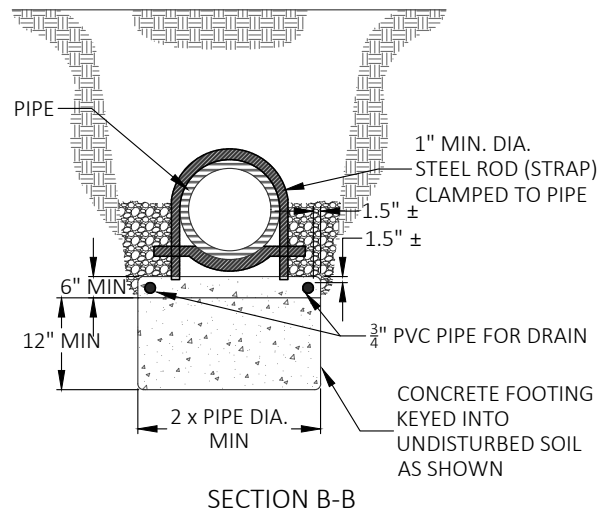
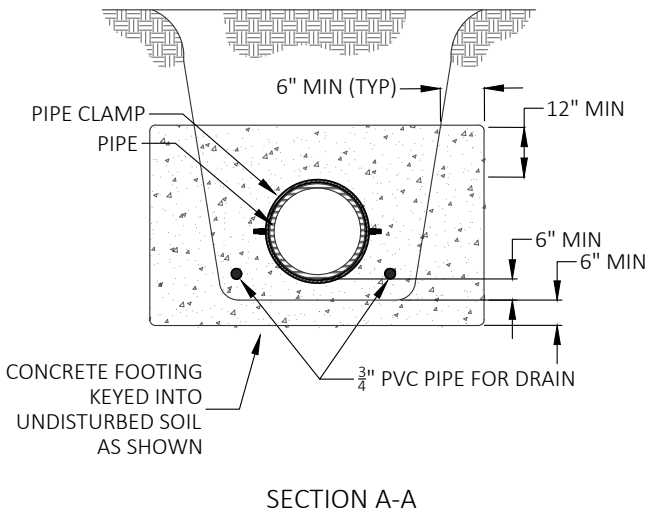
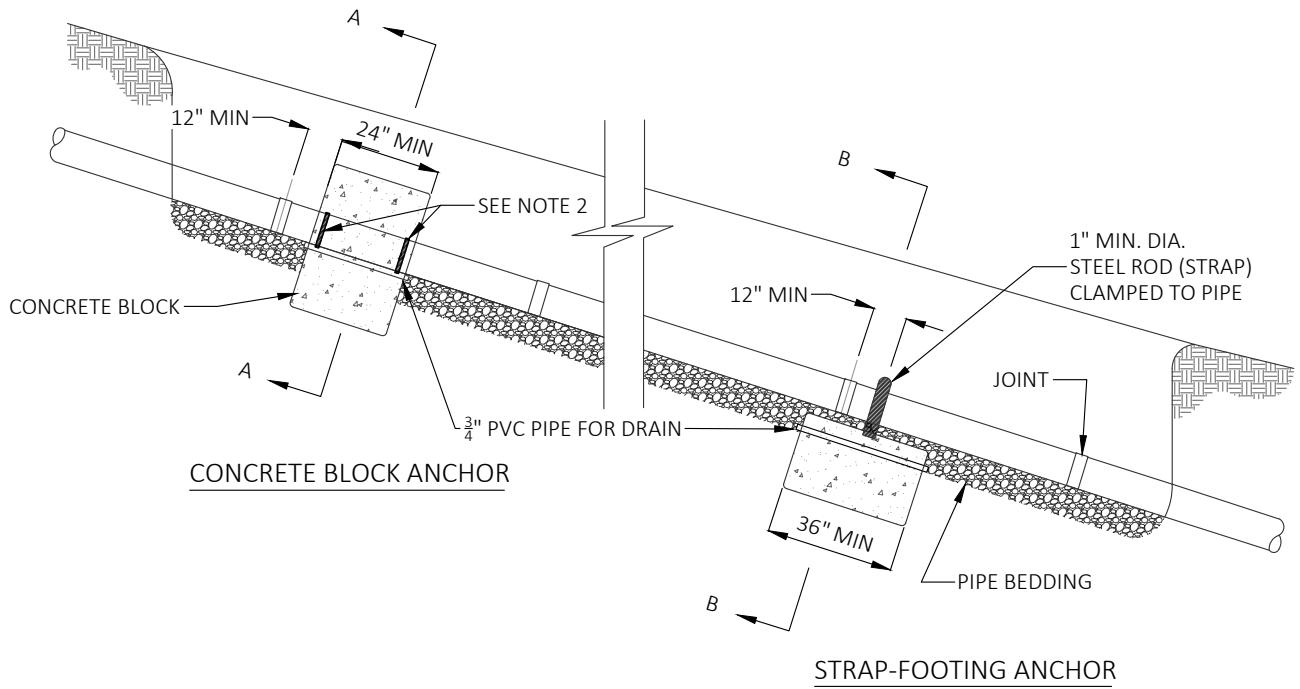

**NOTES:**

1. CONCRETE PIPE ANCHORS OR STRAP-FOOTING ANCHORS REQUIRED ON PIPE SLOPES OF 20% OR GREATER.
2. PLACE TWO PIPE CLAMPS, 4" FROM BLOCK ENDS TO PROVIDE ANCHORAGE TO CONCRETE BLOCK.

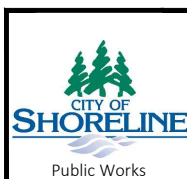

PUBLICATION DATE: <b>03/01/2024</b>	REVISION DATE: <b>09/06/2023</b>
STANDARD DETAIL NUMBER: <b>620</b>	SCALE: <b>NOT TO SCALE</b>

**PIPE ANCHOR DETAIL - SANITARY**

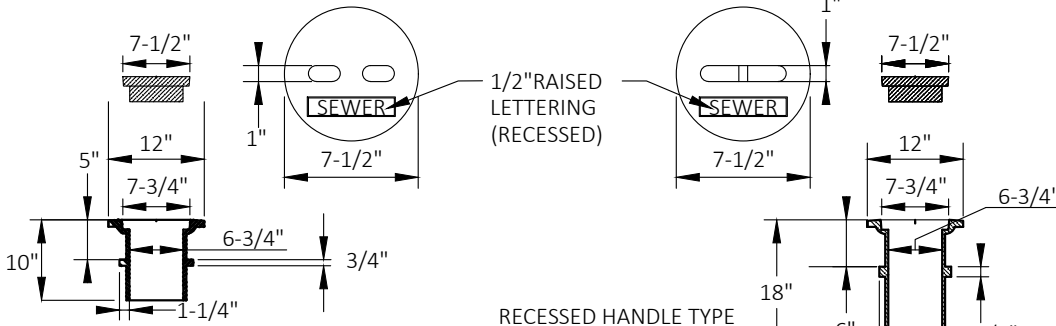

1/2" RAISED LETTERING (RECESSED)

RECESSED HANDLE TYPE LID WITH CITY OF SHORELINE & SEWER CAST IN LID

VALVE BOXES SHALL BE EAST JORDAN (EJ) 10" OR 18", OR OLYMPIC FOUNDRY VB-950 10" OR 18" DUCTILE IRON, MADE IN THE USA

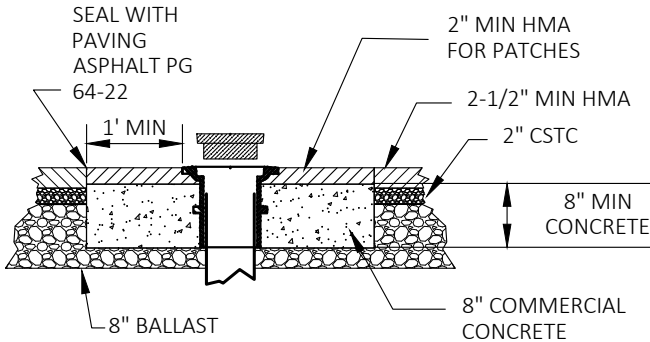

**INSIDE PAVED ROADWAY**

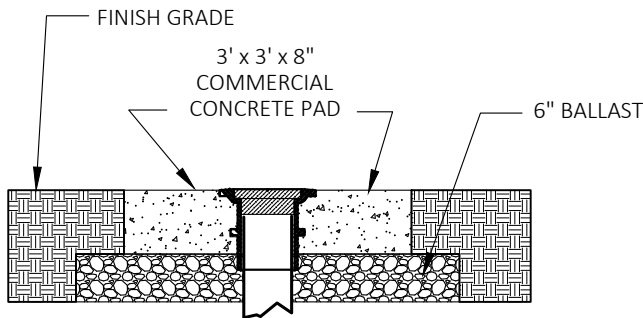
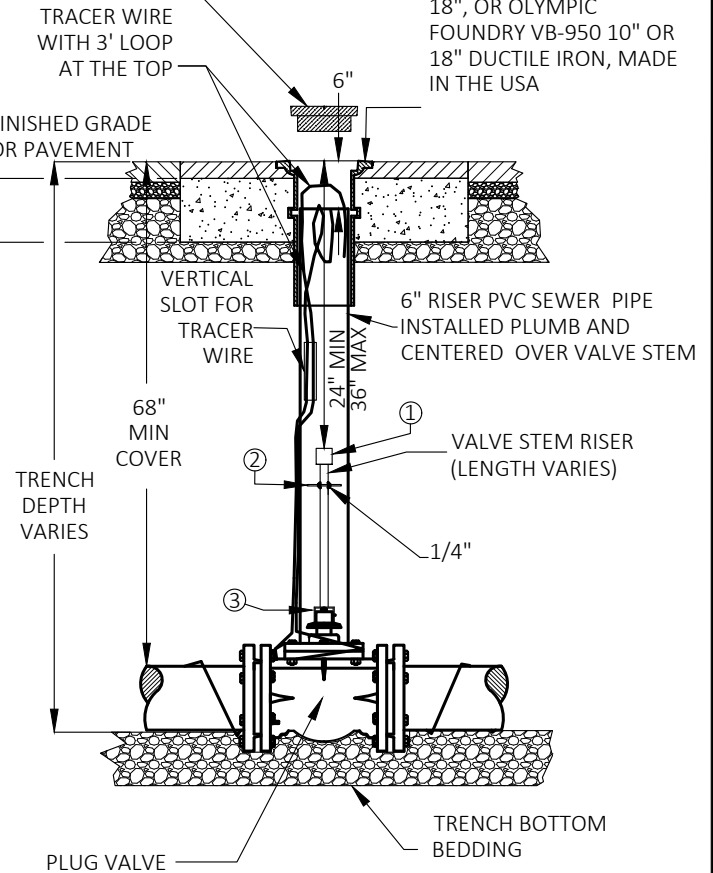

**OUTSIDE PAVED AREA**

**NOTES:**

1. ALL VALVES SHALL HAVE U.S.E. 12 GAUGE GREEN COATED COPPER TRACER WIRE TIED OFF AT VALVE BODY, THE TRACER WIRE SHALL EXTENDED UP ON THE OUTSIDE PVC RISER 1' ABOVE THE HUB THEN SHOULD ENTER THE RISER PIPE AND EXTEND THREE FEET ABOVE THE TOP OF VALVE BOX.
2. ALL WELDS TO THE SHAFT SHALL BE FILLET WELD, AROUND THE ENTIRE PLATE PER #2 BELOW.
3. VALVE BOX LID SHALL HAVE LOCKING RING & COVER WITH STAINLESS STEEL FASTENERS.
4. VALVE BOXES SHALL BE EAST JORDAN (EJ) 10" OR 18", OR OLYMPIC FOUNDRY VB-950 10" OR 18" DUCTILE IRON, MADE IN THE USA.

**VALVE STEM EXTENSION LEGEND**

- ① VALVE OPERATING NUT OR 1-7/8" X 1-7/8" X 2" HIGH GRADE STEEL WELDED TO GUIDE PLATE.
- ② 3/16" THICK X 5 1/5" DIA STEEL GUIDE PLATE WELDED TO RISER SHAFT.
- ③ 2"X2"X 3/16" SQUARE STRUCTURAL STEEL TUBING TO FIT OPERATING NUT. LENGTH AS REQUIRED.

	PUBLICATION DATE: <b>03/01/2024</b>	REVISION DATE: <b>09/06/2023</b>
	STANDARD DETAIL NUMBER: <b>621</b>	SCALE: <b>NOT TO SCALE</b>
<b>VALVE BOX DETAIL - SANITARY</b>		

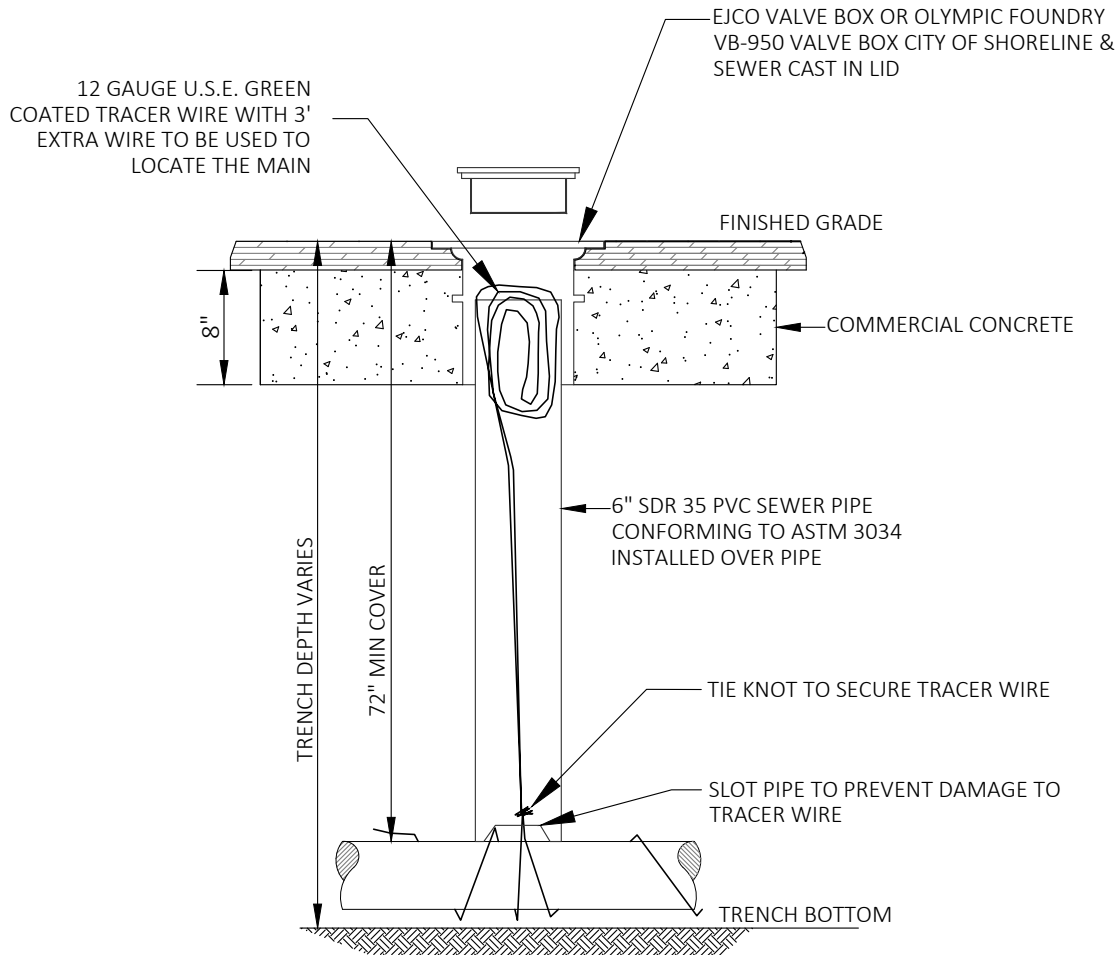

NOTES:

1. TRACER WIRE ACCESS PORT SHALL BE INSTALLED EVERY 500 FEET WHEN NO APPURTENANCES ARE CONNECTED TO IT.
2. RISER LID SHALL HAVE LOCKING RING & COVER WITH STAINLESS STEEL FASTENERS.

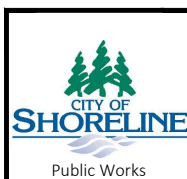

PUBLICATION DATE: **03/01/2024** REVISION DATE: **09/06/2023**

STANDARD DETAIL NUMBER: **622** SCALE: **NOT TO SCALE**

**LOCATE WIRE DETAIL - SANITARY**

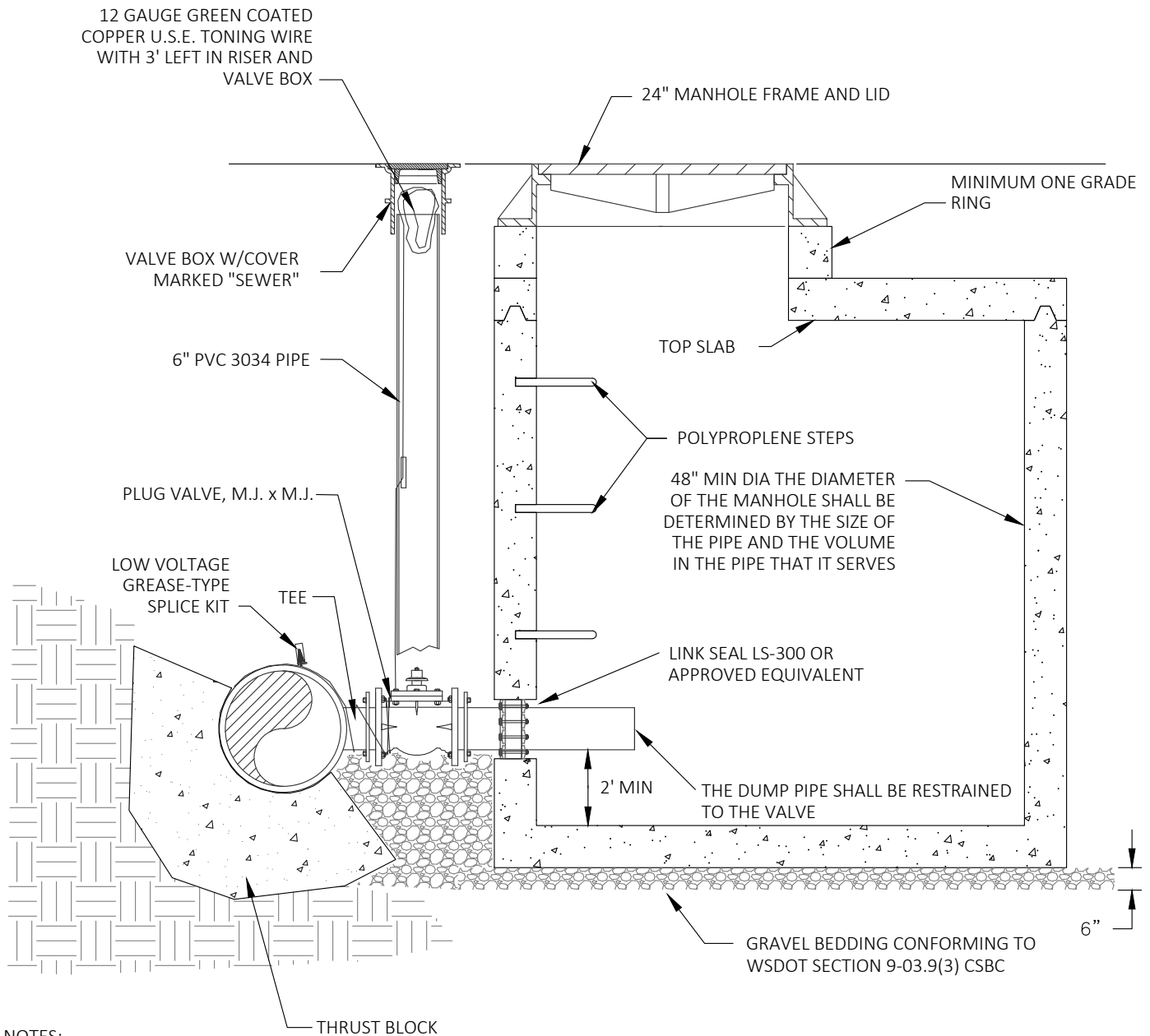

**NOTES:**

1. INSTALL A CONCRETE PAD WHEN LOW POINT DRAIN MANHOLE IS INSTALLED OUTSIDE OF PAVED AREA.
2. VALVE BOX LID SHALL HAVE LOCKING RING AND COVER WITH STAINLESS STEEL FASTENERS.
3. THE SIZE OF THE LOW POINT DRAIN SHALL BE APPROVED BY THE CITY.
4. MAINTAIN 12" MINIMUM CLEARANCE BETWEEN THRUST BLOCK AND FITTING BOLTS ON MECHANICAL JOINTS.
5. USE ONLY MECHANICAL JOINTS WITH PLUG VALVE.
6. PLUG VALVES SHALL BE INSTALLED ON PIPING 4" OR LARGER AND SHALL BE ATTACHED TO THE TEE, CEPEX TRUE UNION VALVES SHALL BE USED ON 3" OR SMALLER SCHEDULE 80 PIPING

 CITY OF SHORELINE Public Works	PUBLICATION DATE: <b>03/01/2024</b>	REVISION DATE: <b>09/06/2023</b>
	STANDARD DETAIL NUMBER: <b>623</b>	SCALE: <b>NOT TO SCALE</b>
<b>LOW POINT DRAIN DETAIL - SANITARY</b>		

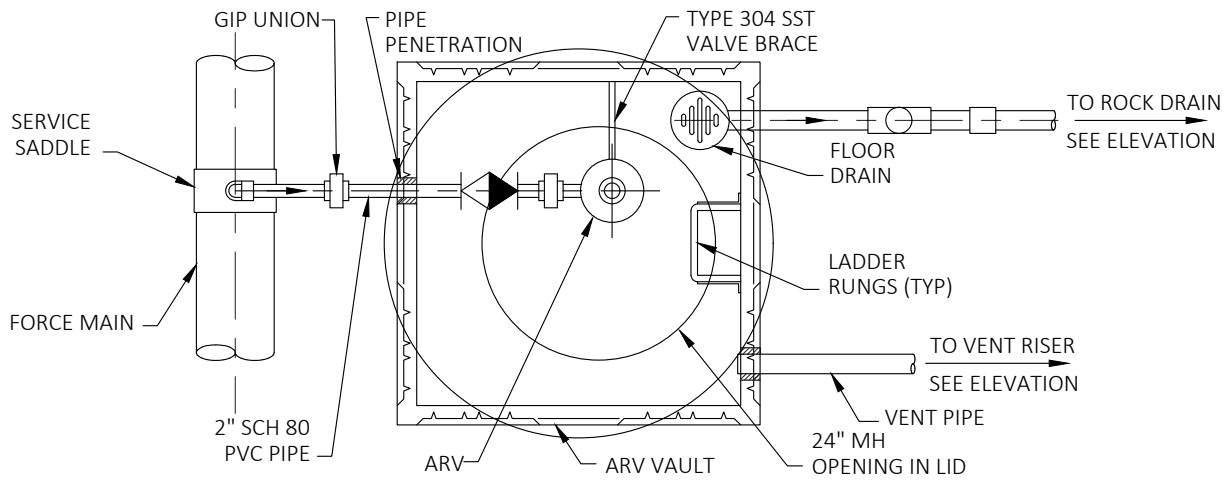

**PLAN**

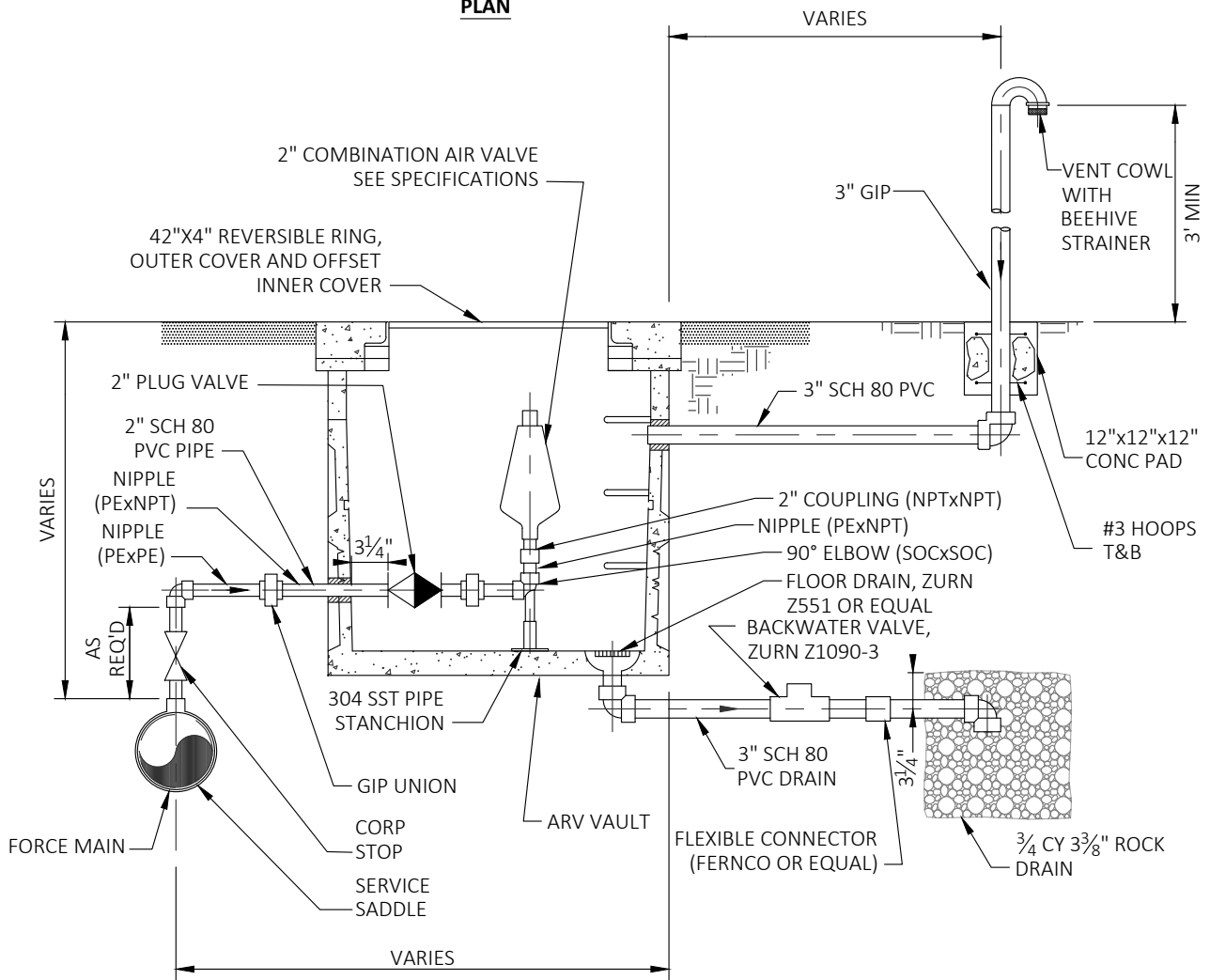

DIMENSIONS TO BE DETERMINED IN FIELD

**ELEVATION**

**NOTE:**

COMBINATION AIR VALVE ASSEMBLY SHALL INCLUDE ALL CONNECTIONS, WORK AND MATERIALS (SERVICE SADDLE TO VENT COWL) FOR A COMPLETE AND FULLY OPERATIONAL COMBINATION AIR VALVE ASSEMBLY

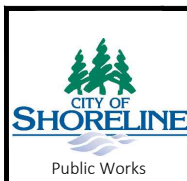

PUBLICATION DATE: **03/01/2024** REVISION DATE: **09/06/2023**

STANDARD DETAIL NUMBER: **624** SCALE: **NOT TO SCALE**

**AIR VALVE VAULT DETAIL - SANITARY**



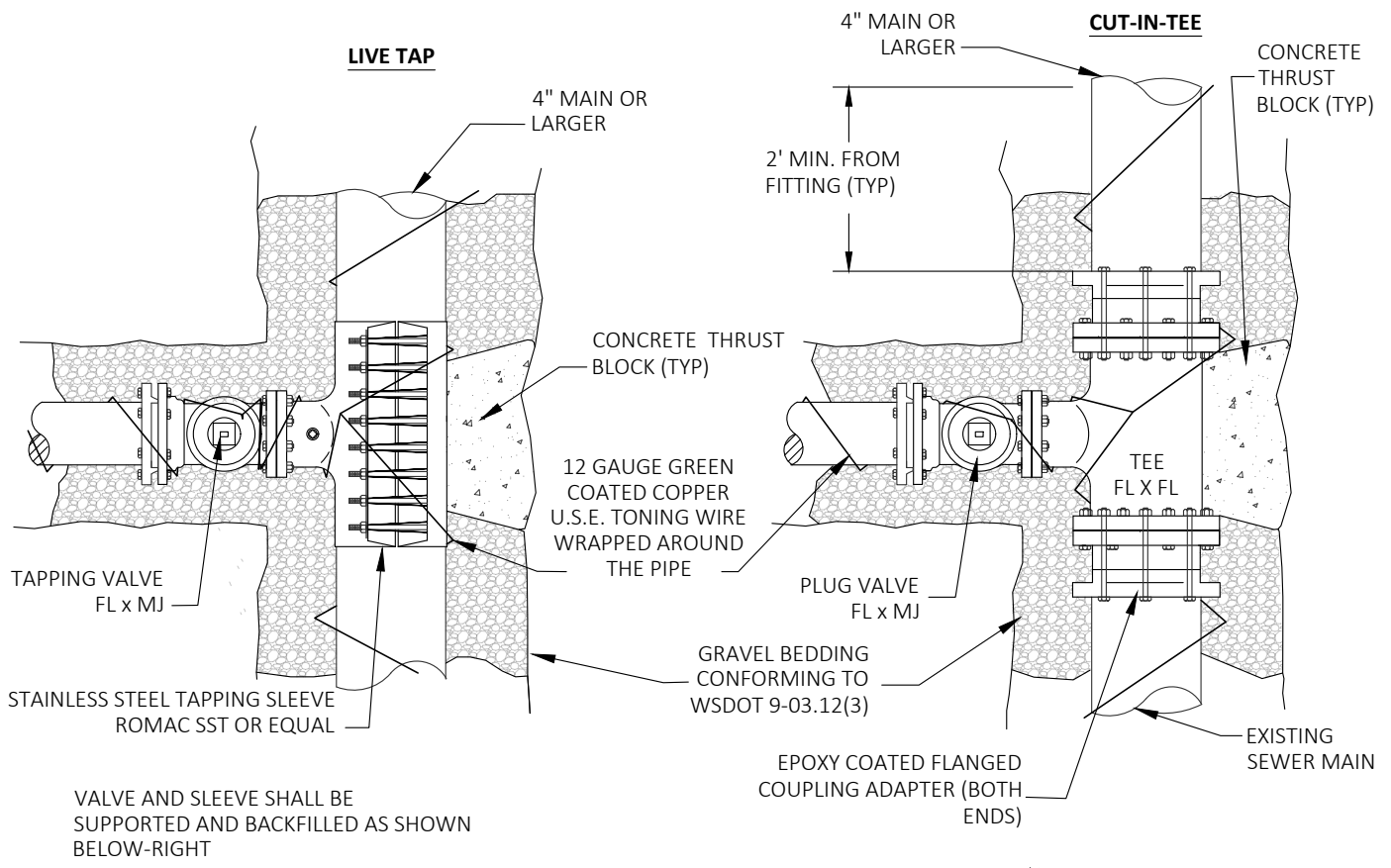

VALVE AND SLEEVE SHALL BE SUPPORTED AND BACKFILLED AS SHOWN BELOW-RIGHT

**SECTION VIEW - THRUST BLOCKING**

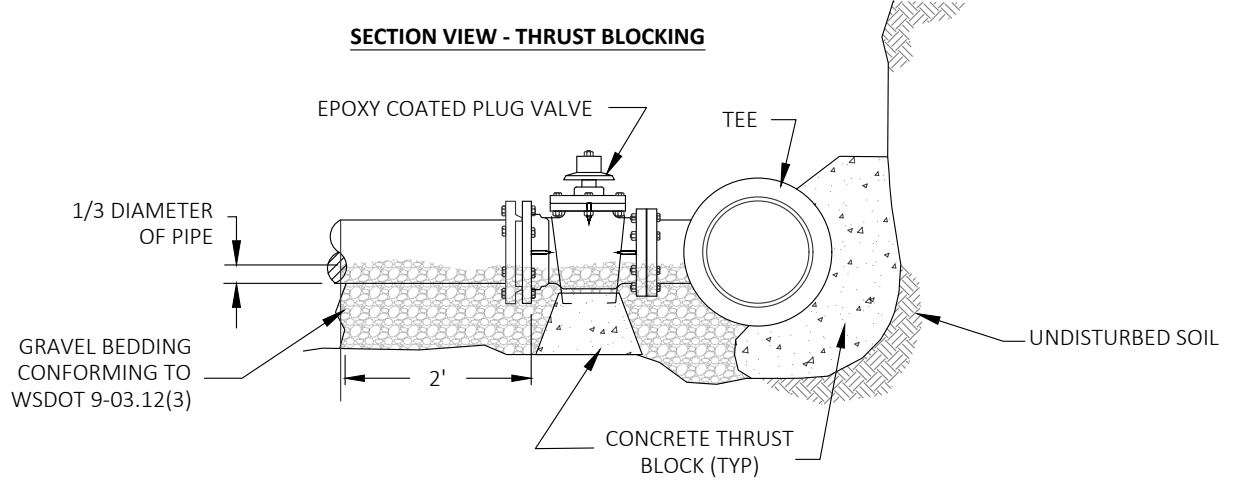

**NOTES:**

1. 11 MIL. PLASTIC OR CONSTRUCTION FABRIC SHALL BE WRAPPED AROUND PIPE AND FITTINGS BEFORE THRUST BLOCKS ARE POURED AND BACKFILLED. THRUST BLOCK SHALL BE CAST AGAINST UNDISTURBED SOIL.
2. THE MINIMUM DISTANCE FOR ANY TAP OR CUT-IN SHALL BE 2' FROM A BELL END OR FITTING.
3. SUPPORT VALVE AND SLEEVE CONTINUOUSLY THROUGH INSTALLATION.
4. CONNECT TO EXISTING TRACER WIRE.
5. CUT-IN TEE SHALL BE EPOXY COATED 10 MILS THICK OR COATED WITH PROTECTO 401 OR APPROVED EQUAL.

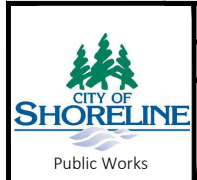

PUBLICATION DATE: <b>03/01/2024</b>	REVISION DATE: <b>09/06/2023</b>
STANDARD DETAIL NUMBER: <b>625</b>	SCALE: <b>NOT TO SCALE</b>

**CONNECTION TO EXISTING  
PRESSURE MAIN DETAIL - SANITARY**

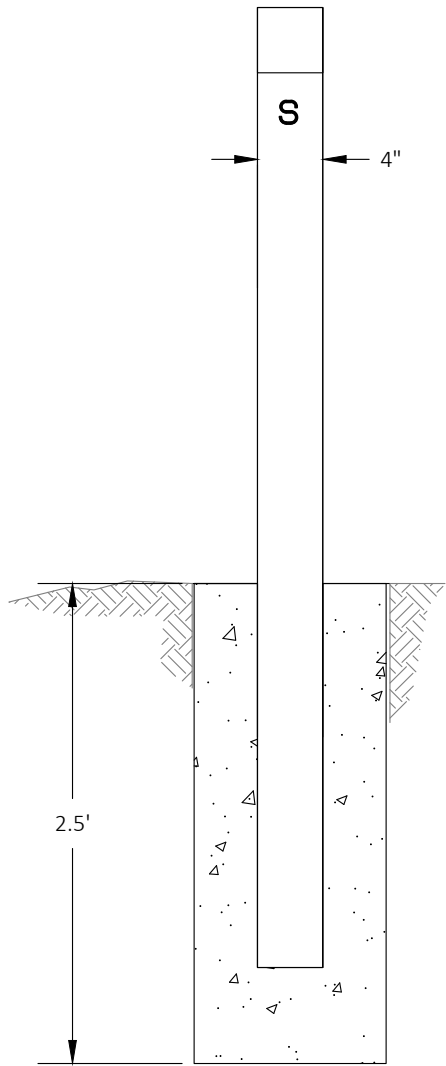

**FRONT**

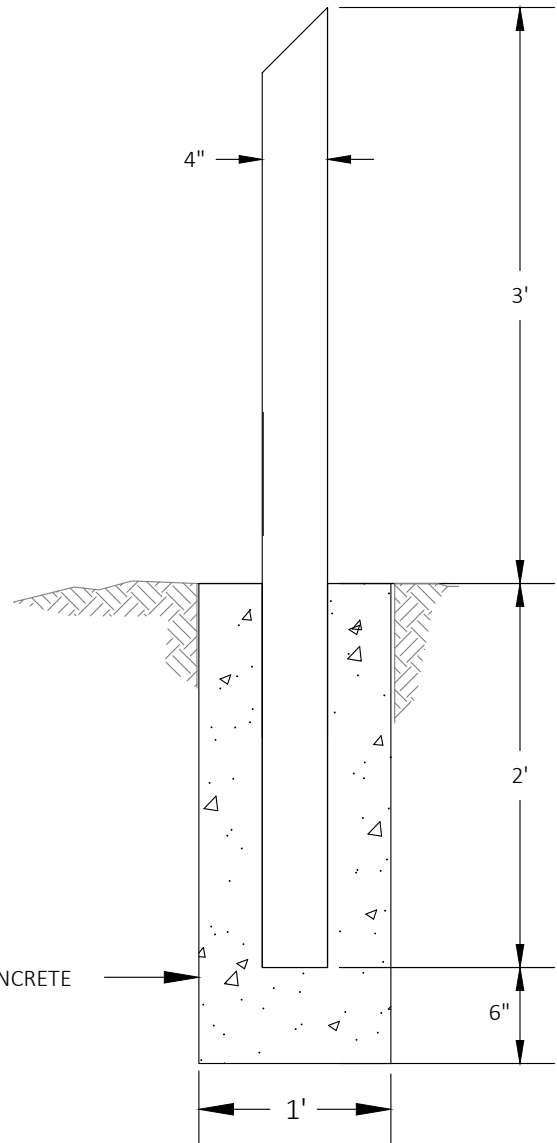

COMMERCIAL CONCRETE

**SIDE**

**NOTES:**

1. 4" SCHEDULE 40 STEEL OR REINFORCED CONCRETE MARKER POST STAMPED WITH A GREEN "S" AND DISTANCE TO VALVE.
2. THE POST TO BE COATED WITH ONE PRIME COAT AND TWO COATS OF OUTDOOR OIL BASE ENAMEL (WHITE).

	PUBLICATION DATE: <b>03/01/2024</b>	REVISION DATE: <b>09/06/2023</b>
	STANDARD DETAIL NUMBER: <b>626</b>	SCALE: <b>NOT TO SCALE</b>
<b>VALVE MARKER DETAIL - SANITARY</b>		

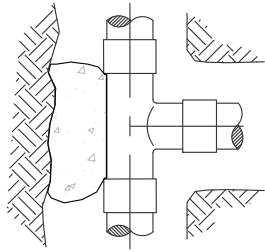

TOP VIEW

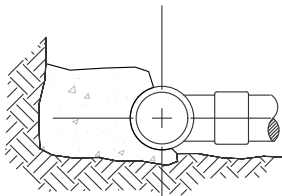

SIDE VIEW

TEE

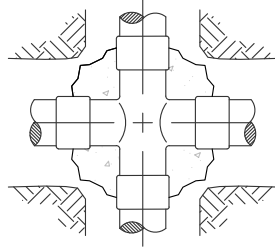

TOP VIEW

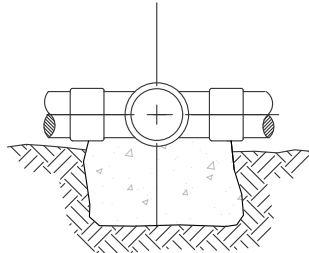

SIDE VIEW

CROSS

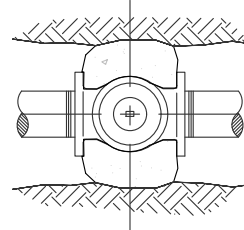

TOP VIEW

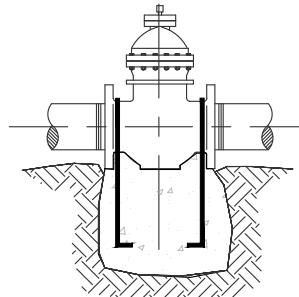

SIDE VIEW

GATE VALVE

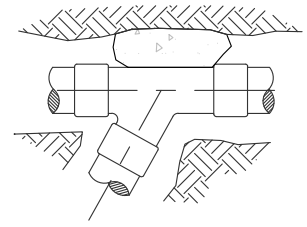

WYE

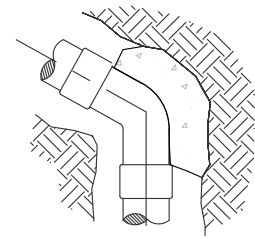

HORIZ. BEND

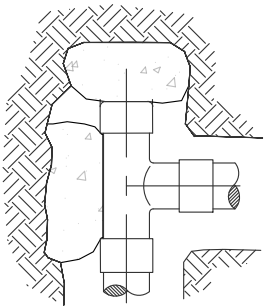

TEE WITH  
PLUG

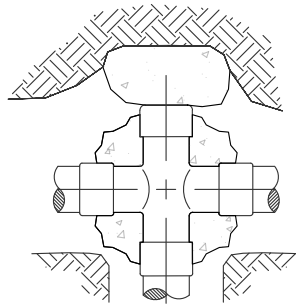

CROSS WITH  
PLUG

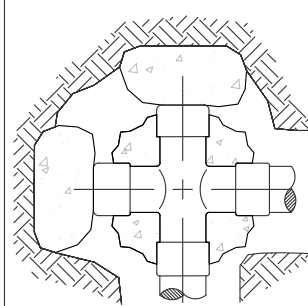

CROSS WITH  
PLUGS

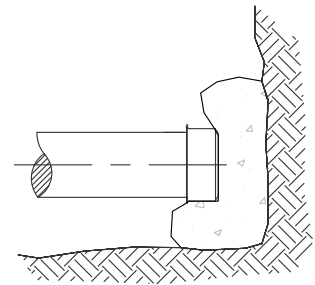

PLUG OR CAP

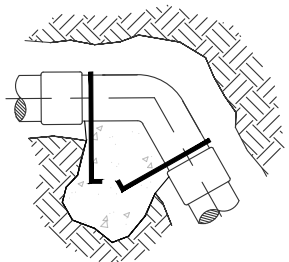

45° - 90°  
VERTICAL BEND

NOTES:

1. CONCRETE THRUST BLOCKING TO BE POURED AGAINST UNDISTURBED EARTH.
2. PLASTIC BARRIER SHALL BE PLACED BETWEEN ALL THRUST BLOCKS AND FITTINGS.
3. ANCHOR REBAR SHALL BE 5/8" MINIMUM DIAMETER.
4. CONCRETE BLOCKING SHALL BE PER APWA SPECIFICATION 7-11.3(13).
5. REBAR REINFORCEMENT SHALL BE DESIGNED BY A LICENSED ENGINEER IN THE STATE OF WASHINGTON



PUBLICATION DATE: **03/01/2024** REVISION DATE: **09/06/2023**

STANDARD DETAIL NUMBER: **627** SCALE: **NOT TO SCALE**

**THRUST BLOCK-VARIOUS DETAIL -  
SANITARY**

**THRUST LOADS**

THRUST AT FITTINGS IN POUNDS AT 200 POUNDS PER SQUARE INCH OF WATER PRESSURE

PIPE DIAMETER	90° BEND	45° BEND	22-1/2° BEND	11-1/4° BEND	DEAD END OR TEE
4"	3,600	2,000	1,000	500	2,600
6"	8,000	4,400	2,300	1,200	5,700
8"	14,300	7,700	4,000	2,000	10,100
10"	22,300	12,100	6,200	3,100	15,800
12"	32,000	17,400	8,900	4,500	22,700
14"	43,600	23,600	12,100	6,100	30,800
16"	57,000	30,800	15,700	7,900	40,300

NOTES:

- BLOCKING SHALL BE COMMERCIAL CONCRETE POURED IN PLACE AGAINST UNDISTURBED EARTH. FITTING SHALL BE ISOLATED FROM CONCRETE THRUST BLOCK WITH PLASTIC OR SIMILAR MATERIAL.
- TO DETERMINE THE BEARING AREA OF THE THRUST BLOCK IN SQUARE FEET (SF):  
EXAMPLE : 12" - 90° BEND IN SAND AND GRAVEL 32,000 LBS 3000 LB/SF = 10.7 SF OF AREA.
- AREAS MUST BE ADJUSTED FOR OTHER PIPE SIZE, PRESSURES AND SOIL CONDITIONS.
- BLOCKING SHALL BE ADEQUATE TO WITHSTAND FULL TEST PRESSURE AS WELL AS TO CONTINUOUSLY WITHSTAND OPERATING PRESSURE UNDER ALL CONDITIONS OF SERVICE.

**SAFE SOIL BEARING LOADS**

FOR HORIZONTAL THRUSTS WHEN THE DEPTH OF COVER OVER THE PIPE EXCEEDS 2 FEET

SOIL	POUNDS PER SQUARE FOOT
MUCK, PEAT	0
SOFT CLAY	1,000
SAND	2,000
SAND & GRAVEL	3,000
SAND & GRAVEL CEMENTED WITH CLAY	4,000
HARD SHALE	10,000

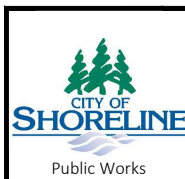

PUBLICATION DATE: **03/01/2024** REVISION DATE: **09/06/2023**

STANDARD DETAIL NUMBER: **628** SCALE: **NOT TO SCALE**

**THRUST LOAD CALCULATION -  
SANITARY**

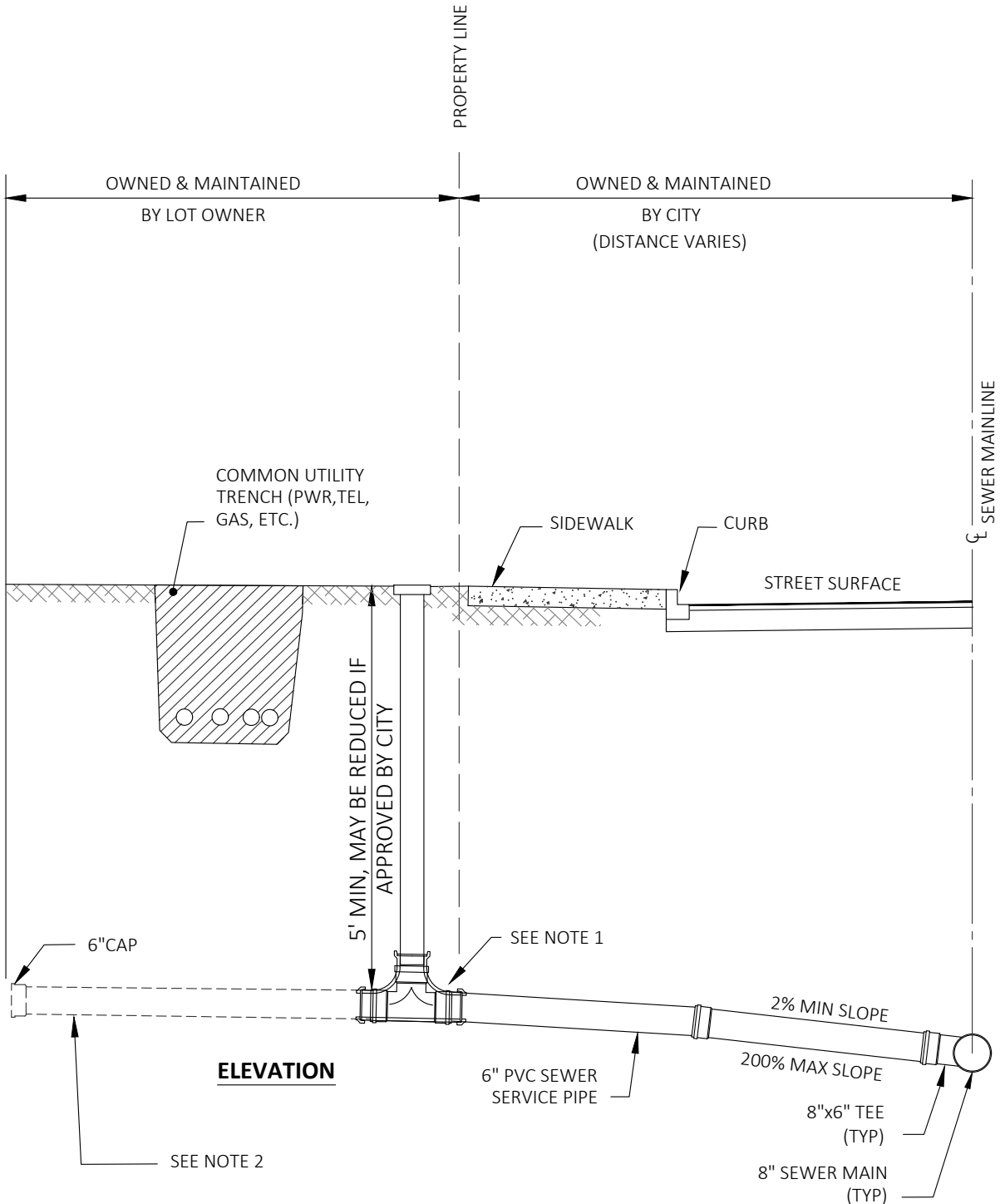

**NOTES:**

1. INSTALL 6"x6"x6" PVC SDR 35 GASKETED 2-WAY CLEANOUT TEE W/PLUG @ PROPERTY LINE. AFTER TEST, EXTEND CLEANOUT TO GRADE WITH LOCKING LID
2. DEVELOPER/CONTRACTOR MAY EXTEND STUB SERVICE DURING SEWER MAIN CONSTRUCTION. STUB MAY NEED TO BE LONGER IF PUBLIC SIDE SEWER WAS NOT FULLY EXTENDED IN ORIGINAL CONSTRUCTION.



PUBLICATION DATE: <b>03/01/2024</b>	REVISION DATE: <b>09/06/2023</b>
STANDARD DETAIL NUMBER: <b>629</b>	SCALE: <b>NOT TO SCALE</b>
<b>SIDE SEWER CONNECTION DETAIL - SANITARY</b>	

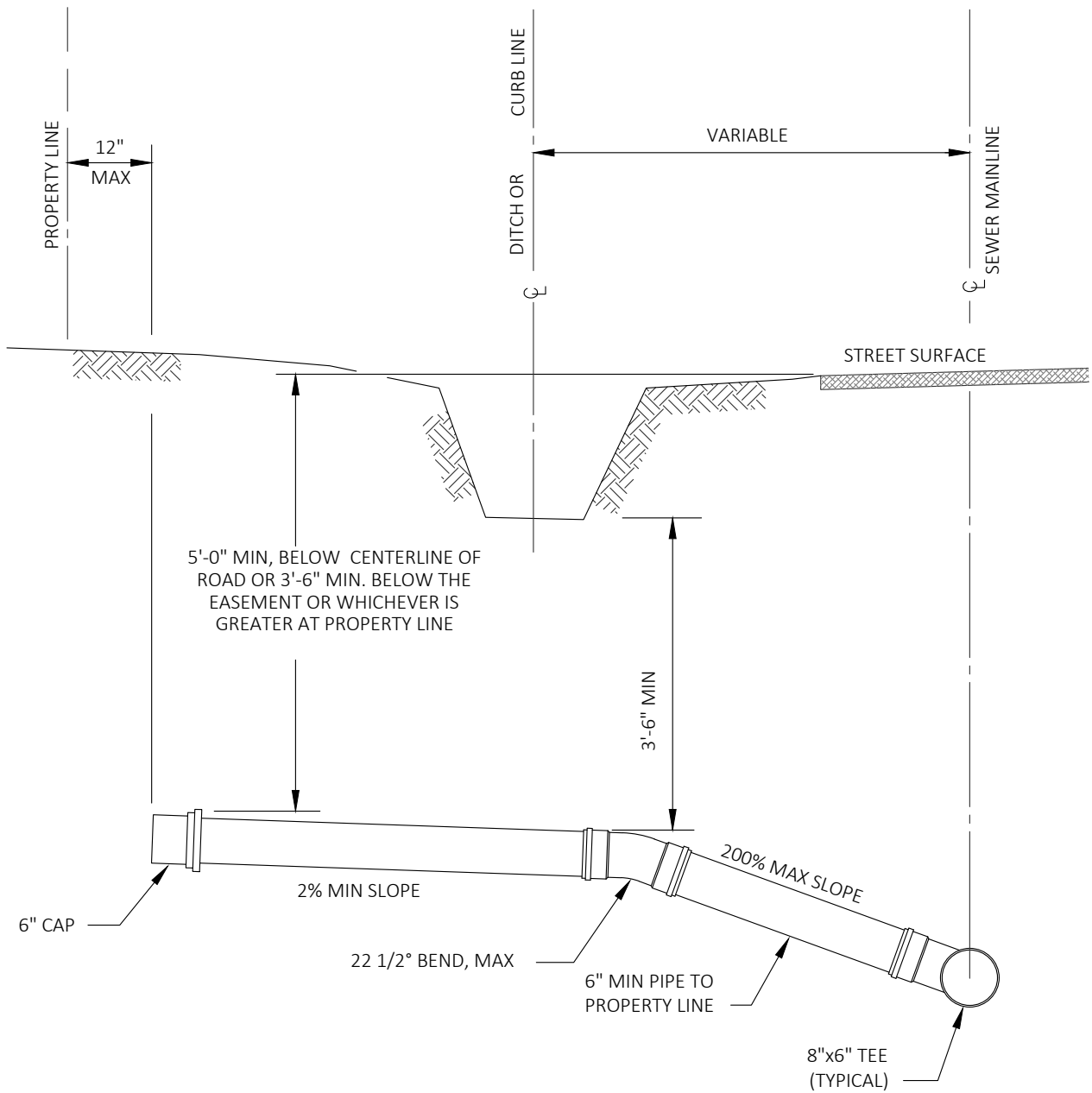

**ELEVATION**

**NOTES:**

1. MAXIMUM ALLOWANCE FOR INSTALLATION IS A 45° MANUFACTURED BEND.

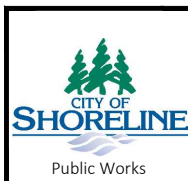

PUBLICATION DATE: **03/01/2024** REVISION DATE: **09/06/2023**

STANDARD DETAIL NUMBER: **630** SCALE: **NOT TO SCALE**

**SANITARY SEWER SERVICE - NEW CONSTRUCTION**

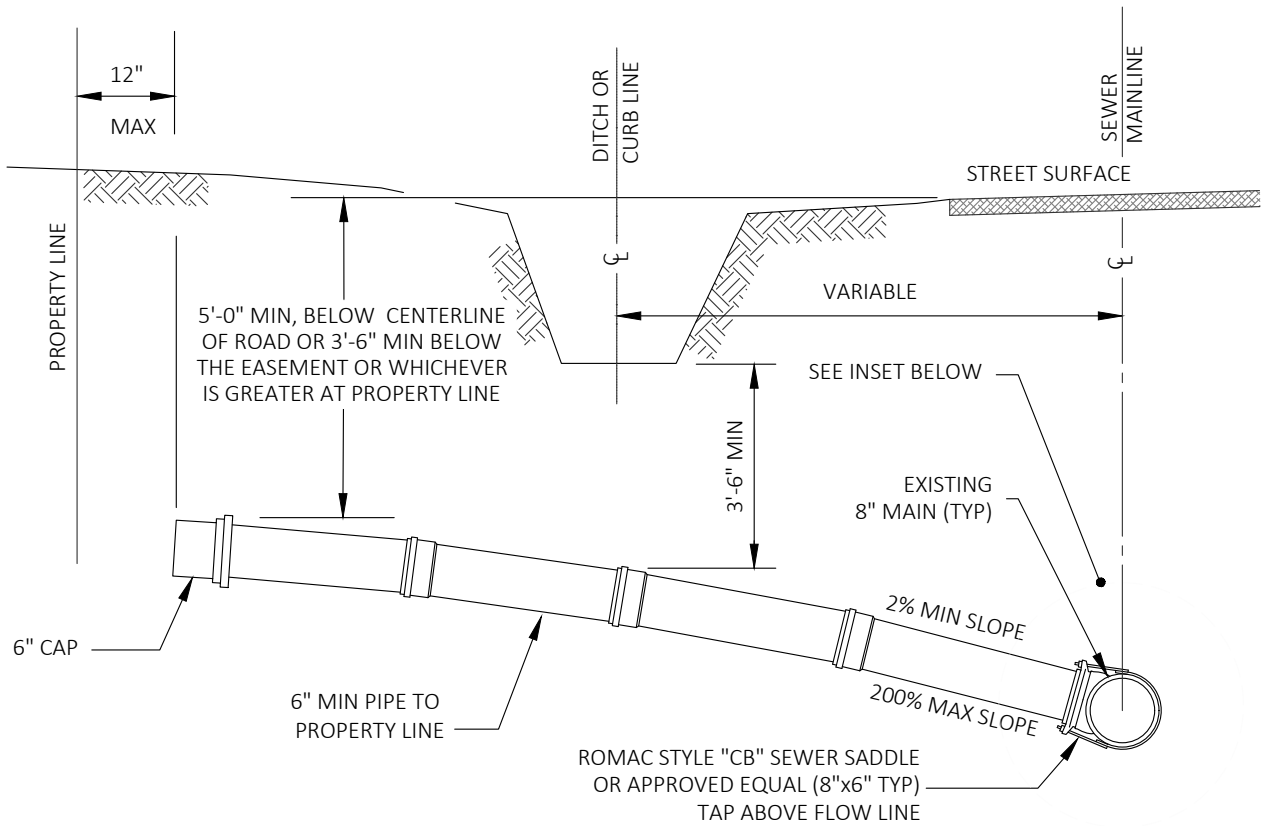

**ELEVATION**

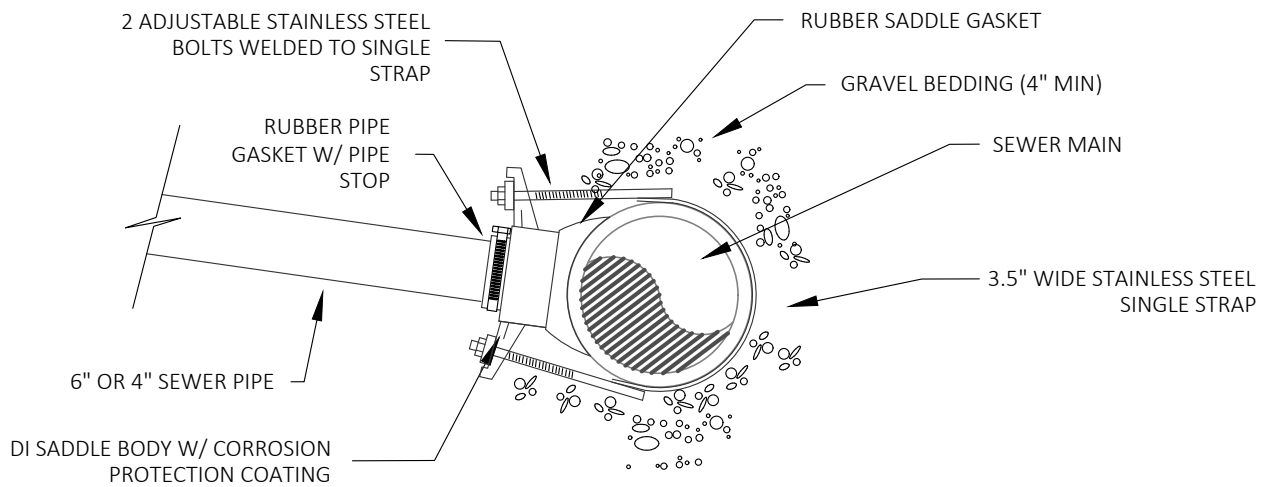

**NOTES:**

1. BRANCH SEWER MUST BE MIN 2" SMALLER THAN SEWER MAIN.
2. FOR STEEL, CAST IRON, ASBESTOS CEMENT, PVC AND CONCRETE PIPE.
3. MAXIMUM DEFLECTION PER JOINT NOT OVER 2" PER FOOT, OR 5" PER STANDARD 30' PIPE SECTION (NOT TO EXCEED PIPE MANUFACTURER'S SPECIFICATIONS).

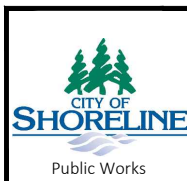

PUBLICATION DATE: **03/01/2024** REVISION DATE: **09/06/2023**

STANDARD DETAIL NUMBER: **631** SCALE: **NOT TO SCALE**

**SADDLE CONNECTION TO SEWER MAIN DETAIL - SANITARY**

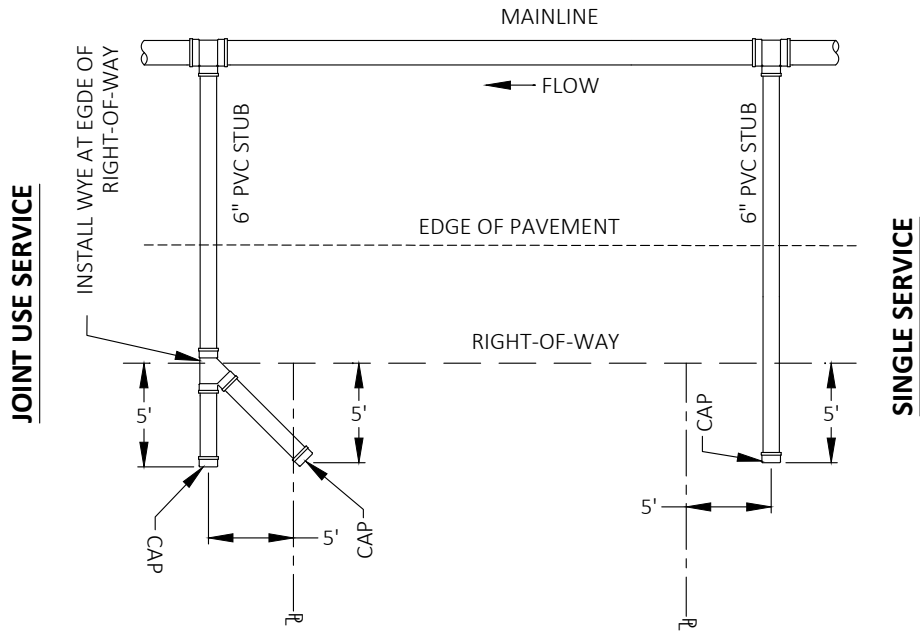

WRAP METALLIC MARKER TAPE AROUND SERVICE MARKER BOARD. 4 WRAPS MINIMUM. RUN UP BOARD TO SURFACE. MIN 4 WRAPS AT TOP.

INSTALL BURIED METALLIC MARKER TAPE 3' ABOVE PIPE. TAPE SHOULD READ "CAUTION BURIED SEWER BELOW," CARLTON IN., BLACKBURN MFG. CO. OR EQUAL.

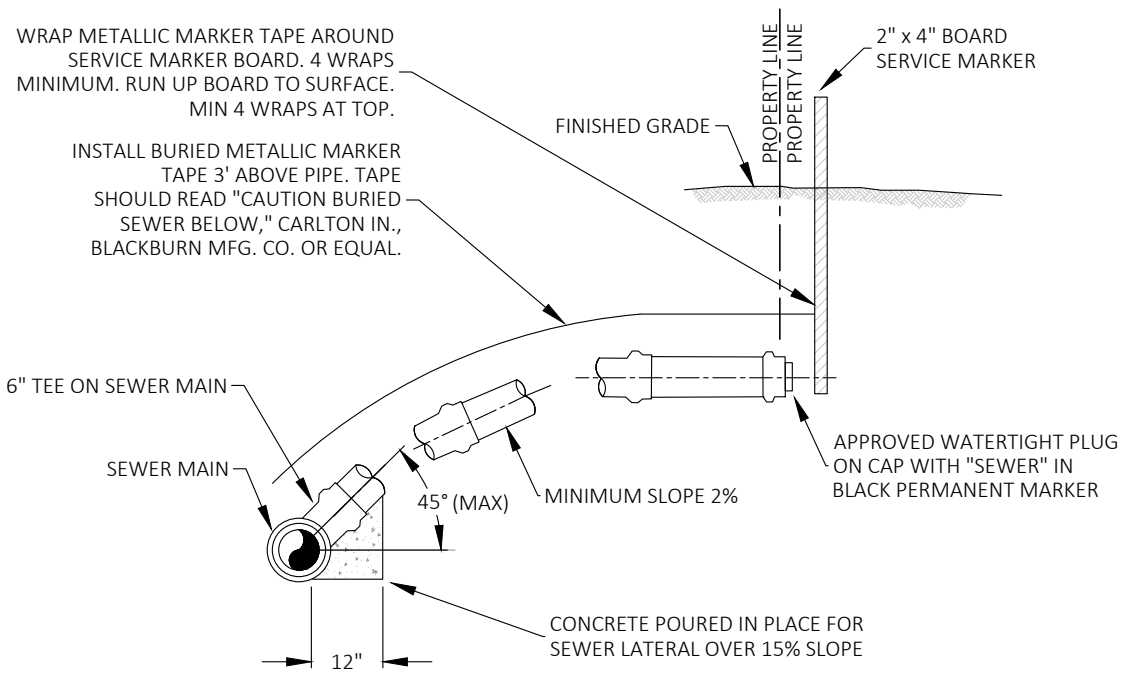

**NOTES:**

1. WHERE SIDE SEWER CONNECTS TO MANHOLE: INVERT OF SIDE SEWER SHALL BE EQUAL TO OR ABOVE MAIN SEWER CROWN, BUT NOT TO EXCEED 18" ABOVE INVERT OF MAIN SEWER.
2. UNLESS OTHERWISE INDICATED ON PLAN, SIDE SEWER SHALL BE MINIMUM OF 6' DEEP AT PROPERTY LINE, OR 5' LOWER THAN THE LOWEST ELEVATION, WHICHEVER IS LOWER.
3. PIPE CAN BE REDUCED TO 4" DIAMETER ON PRIVATE PROPERTY.

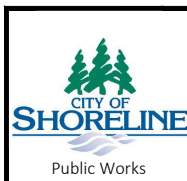

PUBLICATION DATE: **03/01/2024** REVISION DATE: **09/06/2023**

STANDARD DETAIL NUMBER: **632** SCALE: **NOT TO SCALE**

**SANITARY SEWER LATERAL DETAIL**



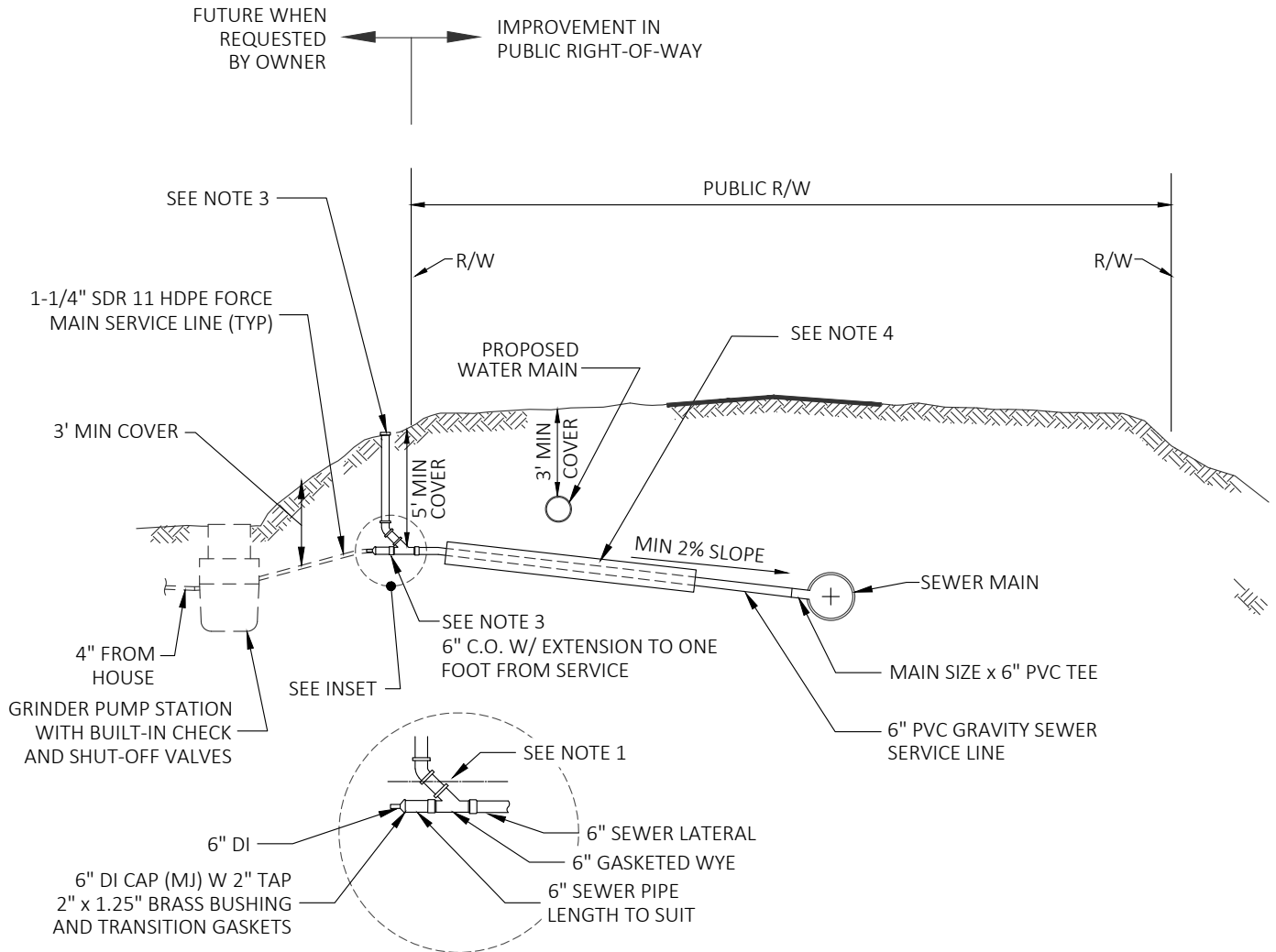

**NOTES:**

1. INSTALL 12-GAUGE SOLID COPPER TRACER WIRE ALONG TOP OF 6" GRAVITY SEWER SERVICE LINE AND HDPE FORCE MAIN SERVICE LINE WITH WARNING TAPE MARKED "SEWER" 12" ABOVE SERVICE LINE. TRACER WIRE SHALL EXTEND FROM 6" TEE AT RIGHT-OF-WAY LINE TEE TO GRINDER PUMP. TRACER WIRE SHALL TERMINATE AT GRINDER PUMP LID WITH 24" OF EXTRA COIL.
2. THE LOCATION OF THE STUB SERVICE TERMINATION SHALL BE MARKED BY THE CONTRACTOR WITH 2"x4" TIMBER EXTENDED VERTICALLY FROM THE PLUG END TO A MINIMUM OF 12" ABOVE THE GROUND SURFACE. A 12-GAUGE GALVANIZED WIRE SHALL BE ATTACHED TO THE TIMBER FROM END TO END. NEITHER THE WIRE NOR THE 2"x4" SHALL BE SECURED OR ATTACHED TO THE SEWER PIPE OR PLUG. THE EXPOSED PORTION OF THE 2"x4" SHALL BE PRE-PAINTED TRAFFIC WHITE WITH THE WORDS "GRINDER PUMP SEWER CONNECTION" STENCILED ON WITH BLACK PAINT. THE END OF THE 2"x4" SHALL BE PRE-MARKED IN PERMANENT INK WITH THE LENGTH OF THE TIMBER INSTALLED.
3. CLEANOUT WITH LOCKING LID AND TAPPED 1-1/4" FIPT.
4. SEWER FORCEMAIN SHALL BE ENCASED WHERE VERTICAL SEPARATION BETWEEN SEWER AND POTABLE WATER PIPE IS LESS THAN 18 INCHES, OR WHEN SEWER PIPE IS ABOVE WATER PIPE, REGARDLESS OF VERTICAL SEPARATION, OR WHEN THE PIPE RUNS BENEATH A DRIVEWAY. CASING SHALL EXTEND AT LEAST TEN FEET ON BOTH SIDES OF ANY WATER PIPELINE CROSSING.
5. INDIVIDUAL GRINDER MANUFACTURER SHALL BE ENVIRONMENT ONE OR EQUIVALENT. THE GRINDER PUMP SYSTEM SHALL BE SUBMITTED AND APPROVED BY THE CITY PRIOR TO INSTALLATION. THE PUMP STATION SHALL CONFORM TO KING COUNTY STANDARDS FOR DESIGN FLOW AND CAPACITY.

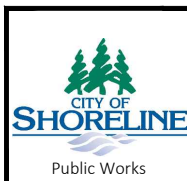

PUBLICATION DATE: **03/01/2024** REVISION DATE: **09/06/2023**

STANDARD DETAIL NUMBER: **633** SCALE: **NOT TO SCALE**

**GRINDER PUMP TO GRAVITY MAIN  
DETAIL - SANITARY**

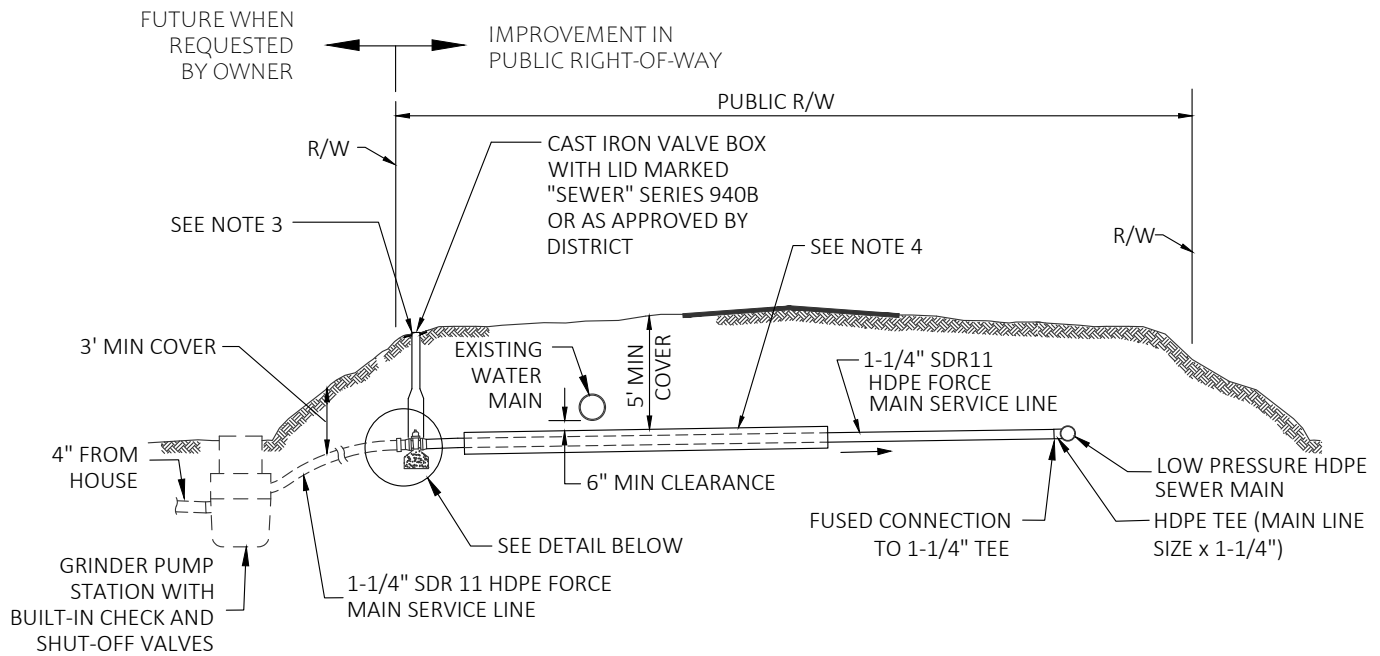

**INDIVIDUAL LIFT STATION (GRINDER) SERVICE CONNECTION**

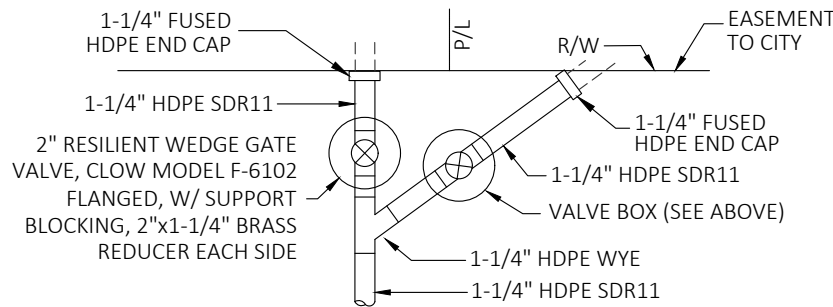

**DOUBLE SERVICE DETAIL**

**NOTES:**

1. INSTALL 12-GAUGE SOLID COPPER TRACER WIRE (NO. W114BLK-500 OR EQUAL) ALONG TOP OF HDPE FORCE MAIN SERVICE LINE WITH WARNING TAPE MARKED "SEWER" 12" ABOVE SERVICE LINE. TRACER WIRE SHALL EXTEND FROM LOW PRESSURE SEWER MAIN TO VALVE AT RIGHT-OF-WAY LINE AND FROM GATE VALVE TO GRINDER PUMP. TRACER WIRE SHALL TERMINATE IN VALVE CAN AND PUMP LID WITH EXTRA 24" OF COIL.
2. THE LOCATION OF THE STUB SERVICE TERMINATION SHALL BE MARKED BY THE CONTRACTOR WITH 2"x4" TIMBER EXTENDED VERTICALLY FROM THE PLUG END TO A MINIMUM OF 12" ABOVE THE GROUND SURFACE. A 12-GAUGE GALVANIZED WIRE SHALL BE ATTACHED TO THE TIMBER FROM END TO END. NEITHER THE WIRE NOR THE 2"x4" SHALL BE SECURED OR ATTACHED TO THE SEWER PIPE OR PLUG. THE EXPOSED PORTION OF THE 2"x4" SHALL BE PRE-PAINTED TRAFFIC WHITE WITH THE WORDS "GRINDER PUMP SEWER CONNECTION" STENCILED IN BLACK PAINT. THE END OF THE 2"x4" SHALL BE PRE-MARKED IN PERMANENT INK WITH THE LENGTH OF THE TIMBER INSTALLED.
3. INSTALL A 2 FOOT SQUARE x 4" THICK ASPHALT OR CONCRETE PAD AROUND THE VALVE BOX AT ALL VACANT LOTS. LOTS WITH EXISTING HOMES WILL HAVE PAD INSTALLED BY THE DISTRICT AFTER GRINDER PUMP CONNECTION IS COMPLETED.
4. SEWER FORCEMAIN SHALL BE ENCASED WHERE VERTICAL SEPARATION BETWEEN SEWER AND POTABLE WATER PIPE IS LESS THAN 18 INCHES, OR WHEN SEWER PIPE IS ABOVE WATER PIPE, REGARDLESS OF VERTICAL SEPARATION, OR WHEN THE PIPE RUNS BENEATH A DRIVEWAY. CASING SHALL EXTEND AT LEAST TEN FEET ON BOTH SIDES OF ANY WATER PIPELINE CROSSING.
5. INDIVIDUAL GRINDER LIFT STATION MANUFACTURER SHALL BE ENVIRONMENT ONE OR EQUIVALENT. THE GRINDER PUMP SYSTEM SHALL BE SUBMITTED TO AND APPROVED BY THE CITY PRIOR TO INSTALLATION. THE PUMP STATION SHALL CONFORM TO KING COUNTY STANDARDS FOR DESIGN FLOW AND CAPACITY.

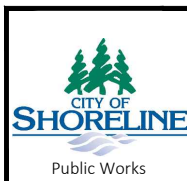

PUBLICATION DATE: **03/01/2024** REVISION DATE: **09/06/2023**

STANDARD DETAIL NUMBER: **634** SCALE: **NOT TO SCALE**

**GRINDER PUMP TO LOW PRESSURE FORCE MAIN**

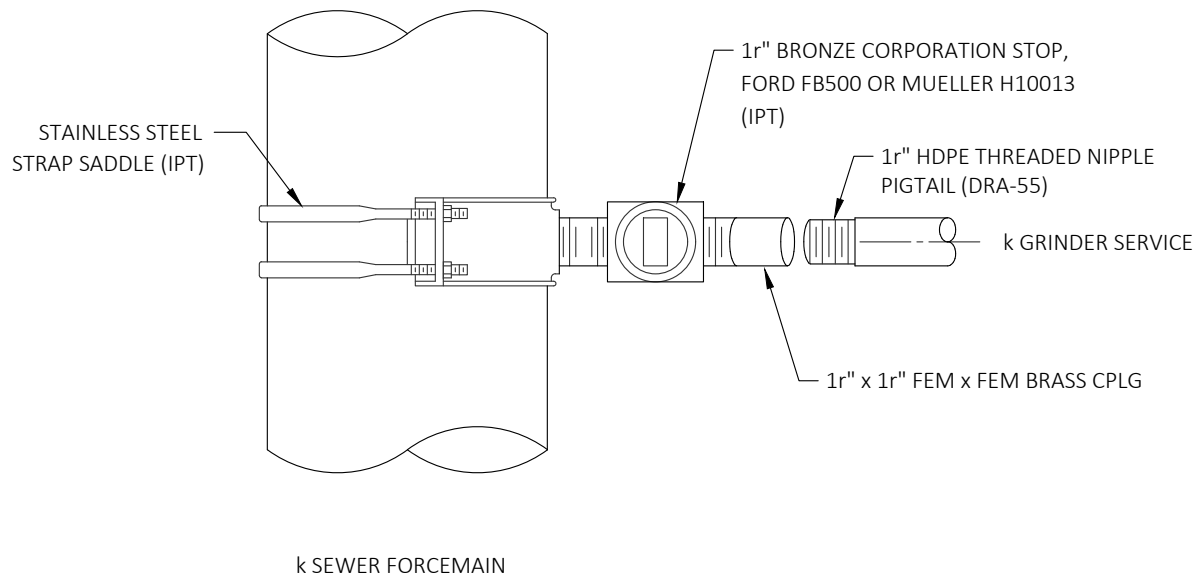

**PLAN**

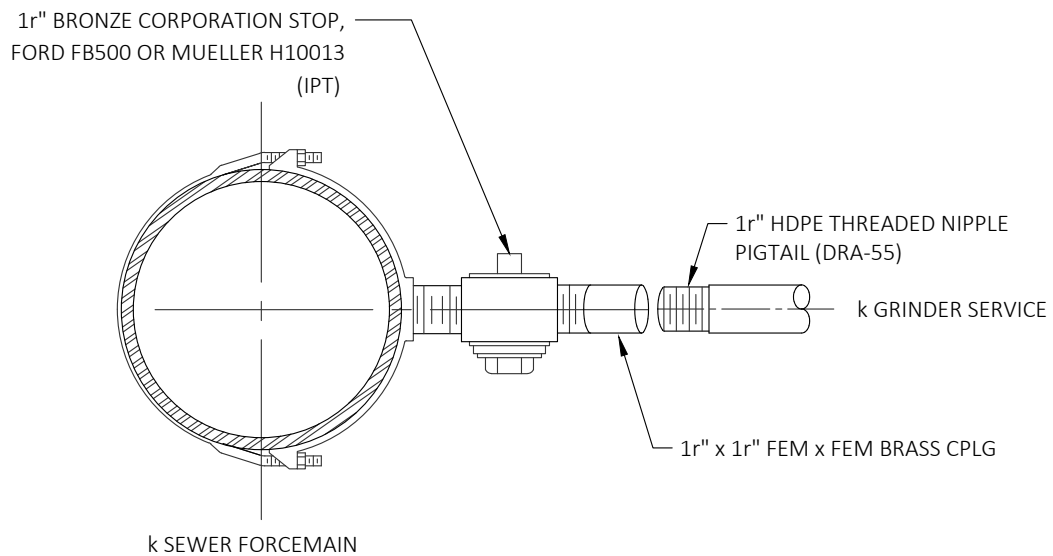

**ELEVATION**

**NOTE**

1. GRINDER LINE FITTINGS: ALL FITTINGS SHALL BE CAST FROM WATER WORKS BRASS CONFORMING TO C800-89.
2. MUNICIPAL SERVICE PIPE: IRON PIPE SIZE SDR 11 WITH TRACER WIRE AND WARNING TAPE MARKED "SEWER" 12" ABOVE.
3. FOR HDPE FORCE MAIN, USE SPRING WASHERS ON SADDLE.

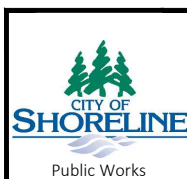

PUBLICATION DATE: **03/01/2024** REVISION DATE: **09/06/2023**

STANDARD DETAIL NUMBER: **635** SCALE: **NOT TO SCALE**

**GRINDER PUMP CONNECTION TO FORCEMAIN - SANITARY**

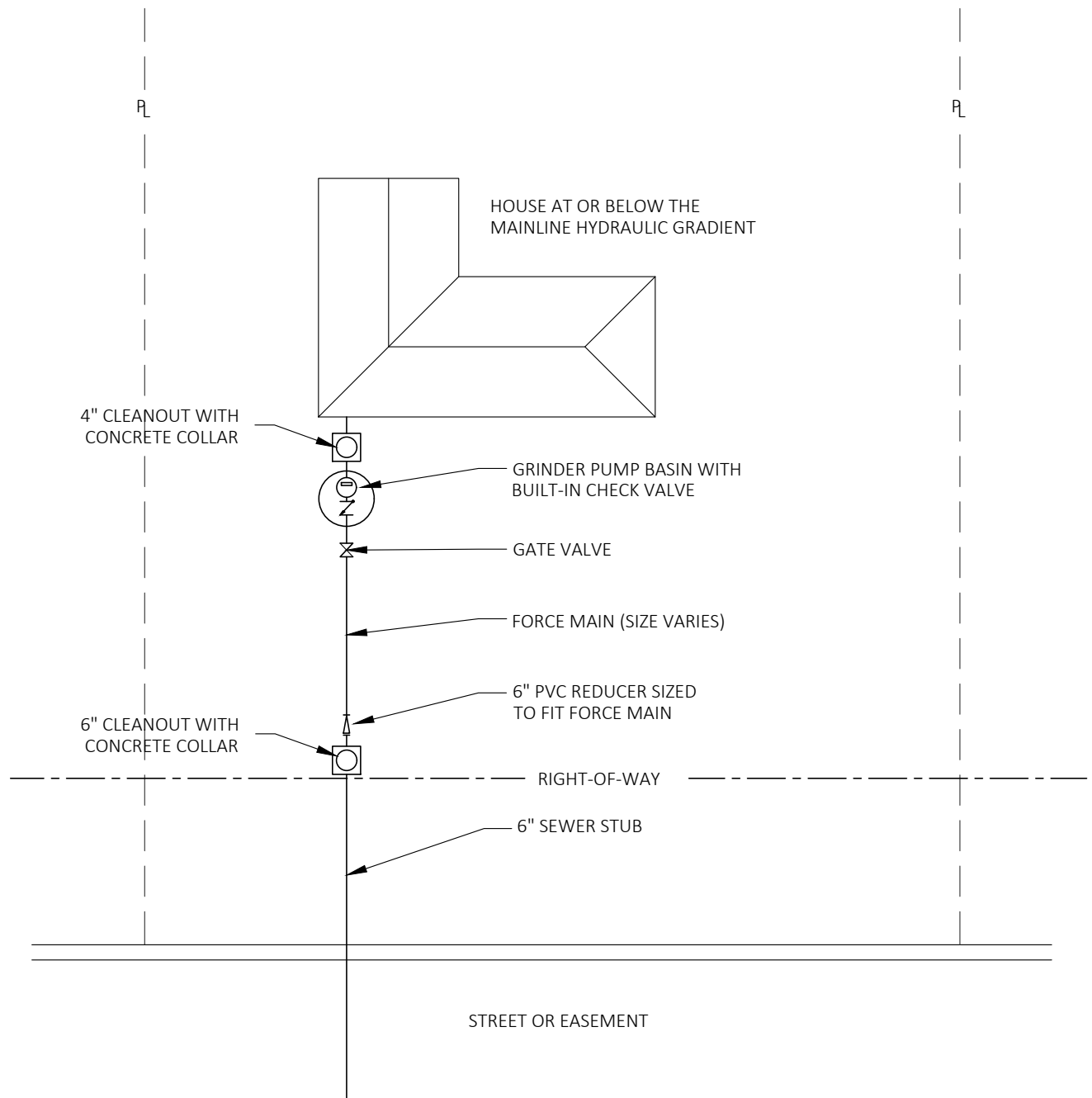

**NOTES:**

1. PUMP SHALL NOT BE CONNECTED TO A SEPTIC TANK OF ANY SIZE.
2. CHECK VALVES AND PUMP ASSEMBLIES ARE PRIVATE AND SHALL BE THE PROPERTY OWNERS RESPONSIBILITY TO MAINTAIN.
3. PUMP BASIN SYSTEM SHALL BE DESIGNED BY THE PUMP MANUFACTURER.
4. ALL CLEANOUTS SHALL BE INSTALLED TO GRADE PER COS STD 645.
5. FORCE MAIN TO 6" GRAVITY STUB CONNECT MUST BE MADE WITH PVC REDUCER, NOT FLEXIBLE COUPLING.
6. FORCE MAIN TESTING SHALL BE IN ACCORDANCE WITH SECTION 7-17.3 OF THE WSDOT STANDARD SPECIFICATIONS.

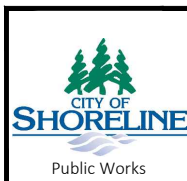

PUBLICATION DATE: <b>03/01/2024</b>	REVISION DATE: <b>09/06/2023</b>
STANDARD DETAIL NUMBER: <b>636</b>	SCALE: <b>NOT TO SCALE</b>

## GRINDER PUMP SYSTEM SCHEMATIC

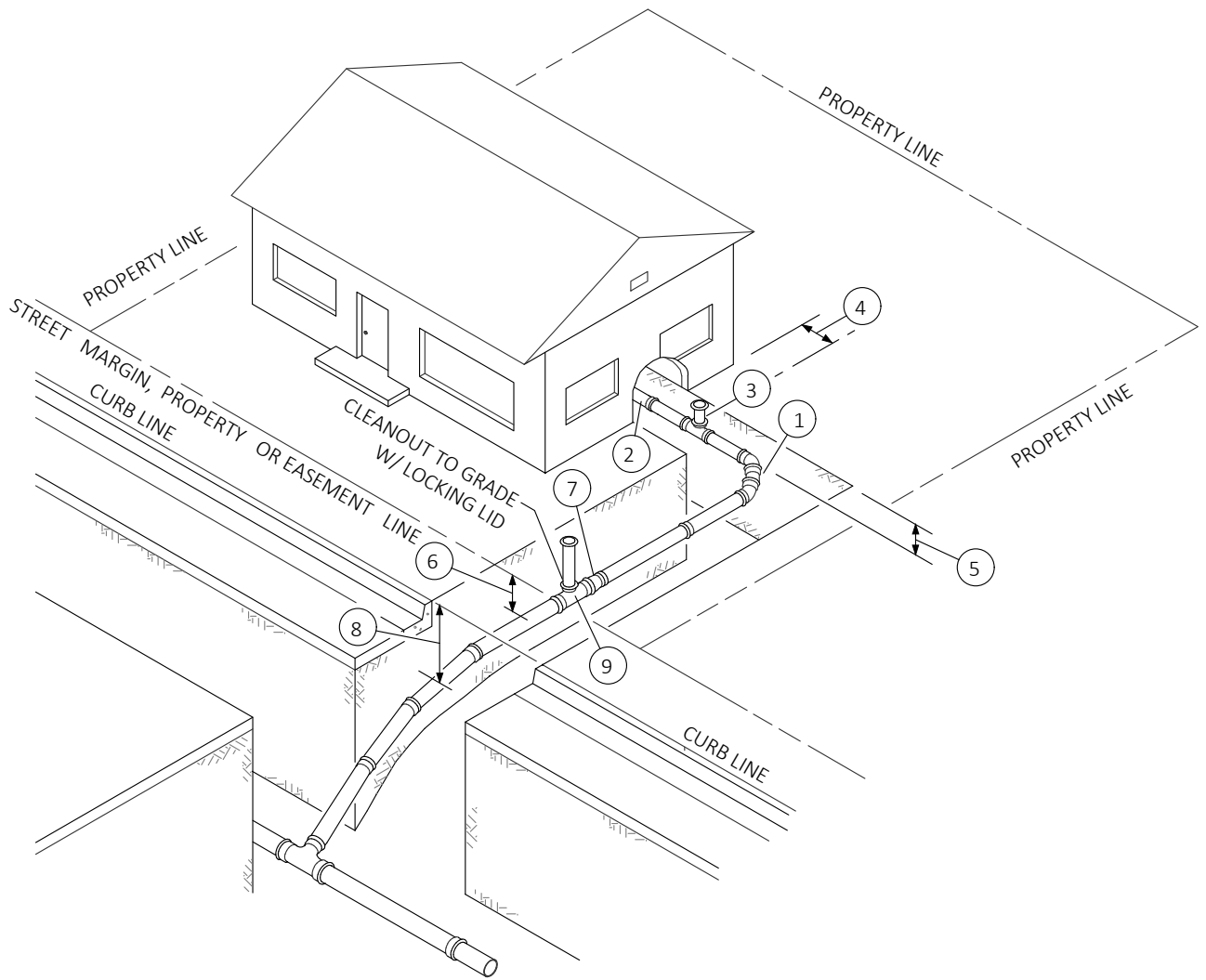

NOTES

- ① 2 - 45° BENDS WITH 24" MIN SEPARATION BETWEEN BENDS TO EQUAL 90° BEND.
- ② CONNECTION TO MAIN STACK FROM SIDE SEWER SHALL BE DUCTILE IRON OR PVC PIPE WITH STRONGBACK FERNCO COUPLING OR EQUAL.
- ③ 4" WYE OR TEE WITH CLEANOUT EXTENDED TO SURFACE.
- ④ 18" MINIMUM OR 30" MAXIMUM DISTANCE FROM HOUSE. IF ACCESS IS PREVENTED BY PORCH OR DECKS, THEN SURFACE CLEAN-OUT IS REQUIRED (SEE DETAIL NO. 30).
- ⑤ 18" MINIMUM COVER.
- ⑥ 5'-0" MINIMUM BELOW STREET CENTERLINE OR 3'-6" MINIMUM BELOW EASEMENT LINE ELEVATION, WHICHEVER IS DEEPER @ THE PROPERTY OR EASEMENT LINE.
- ⑦ STANDARD 4" TO 6" INCREASER.
- ⑧ 6'-0" MINIMUM BELOW ROAD GRADE OR CURB LINE.
- ⑨ 6"x6"x6" TEST TEE SHALL BE LOCATED INSIDE PRIVATE PROPERTY.

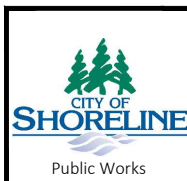

PUBLICATION DATE: **03/01/2024** REVISION DATE: **09/06/2023**

STANDARD DETAIL NUMBER: **637** SCALE: **NOT TO SCALE**

**HOUSE LATERAL CONNECTION TO GRAVITY MAIN - SANITARY**

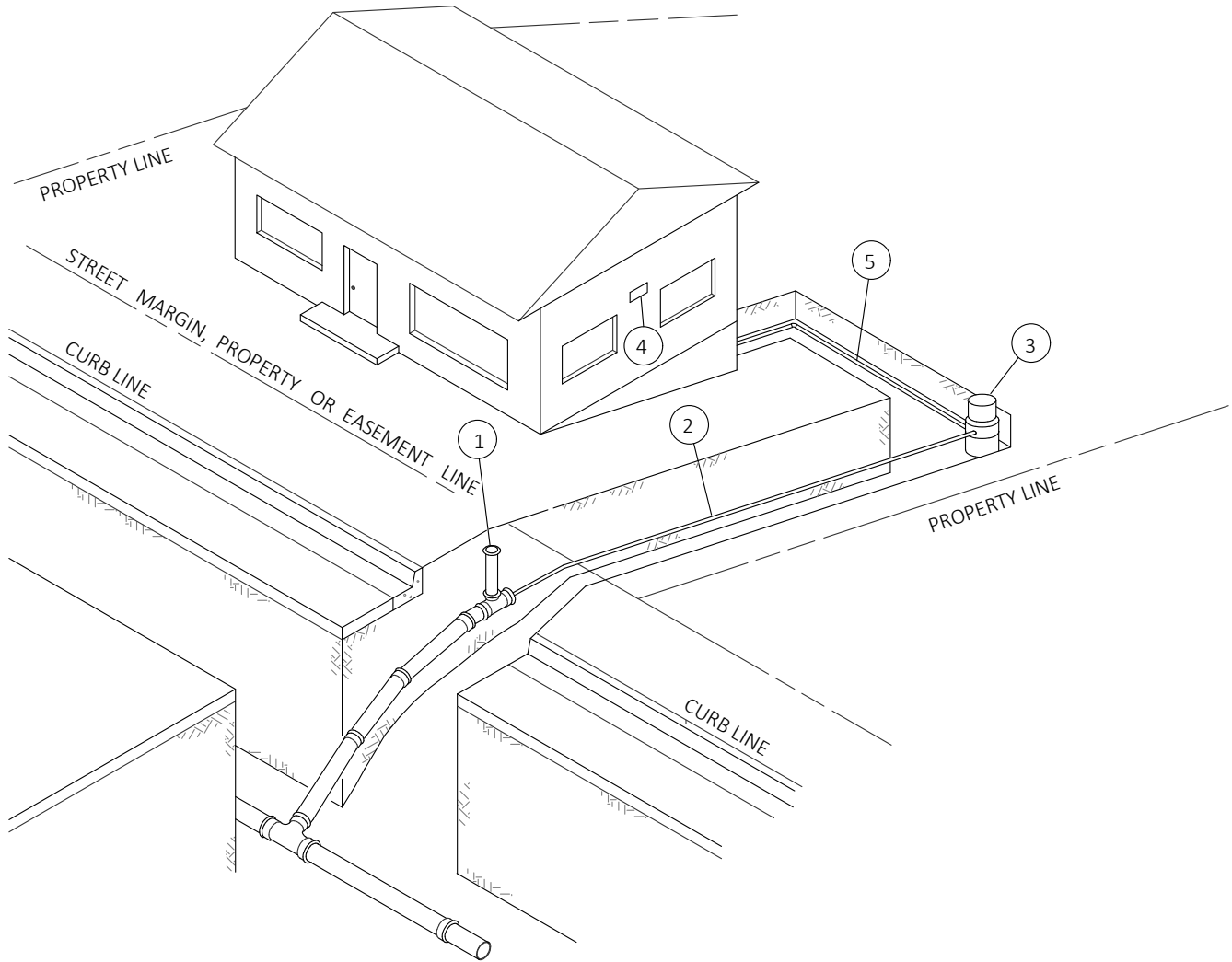

**NOTES**

- ① 6" TEE x MJ TAPPED WITH 1-1/4" NPT. EXTEND CLEANOUT PIPE TO SURFACE WITH LOCKING LID AFTER TESTING.
- ② 1-1/4" HDPE (TYP) ON-SITE SERVICE LINE WITH 16-GAUGE SOLID COPPER TRACER WIRE ALONG TOP OF HDPE FORCE MAIN AND WARNING TAPE MARKED "SEWER" 12" ABOVE.
- ③ GRINDER PUMP BASIN WITH PUMP ASSEMBLY AND BUILT-IN CHECK VALVE.
- ④ PUMP CONTROL PANEL WITH ALARM LIGHT. LOCATION MUST BE IN DIRECT LINE OF SIGHT FROM GRINDER PUMP, 3' MIN, 5' MAX ABOVE GROUND. CONTROL WIRE TO BE PLACED IN 1" MIN. CONDUIT FROM PANEL TO GRINDER PUMP.
- ⑤ GRAVITY HOUSE SERVICE TO GRINDER PUMP.
- ⑥ CONTACT THE CITY TO SCHEDULE AN ON-SITE PRECONSTRUCTION MEETING PRIOR TO ANY WORK.

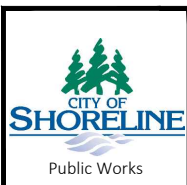

PUBLICATION DATE: <b>03/01/2024</b>	REVISION DATE: <b>09/06/2023</b>
STANDARD DETAIL NUMBER: <b>638</b>	SCALE: <b>NOT TO SCALE</b>
<b>HOUSE CONNECTION TO GRINDER PUMP - SANITARY</b>	

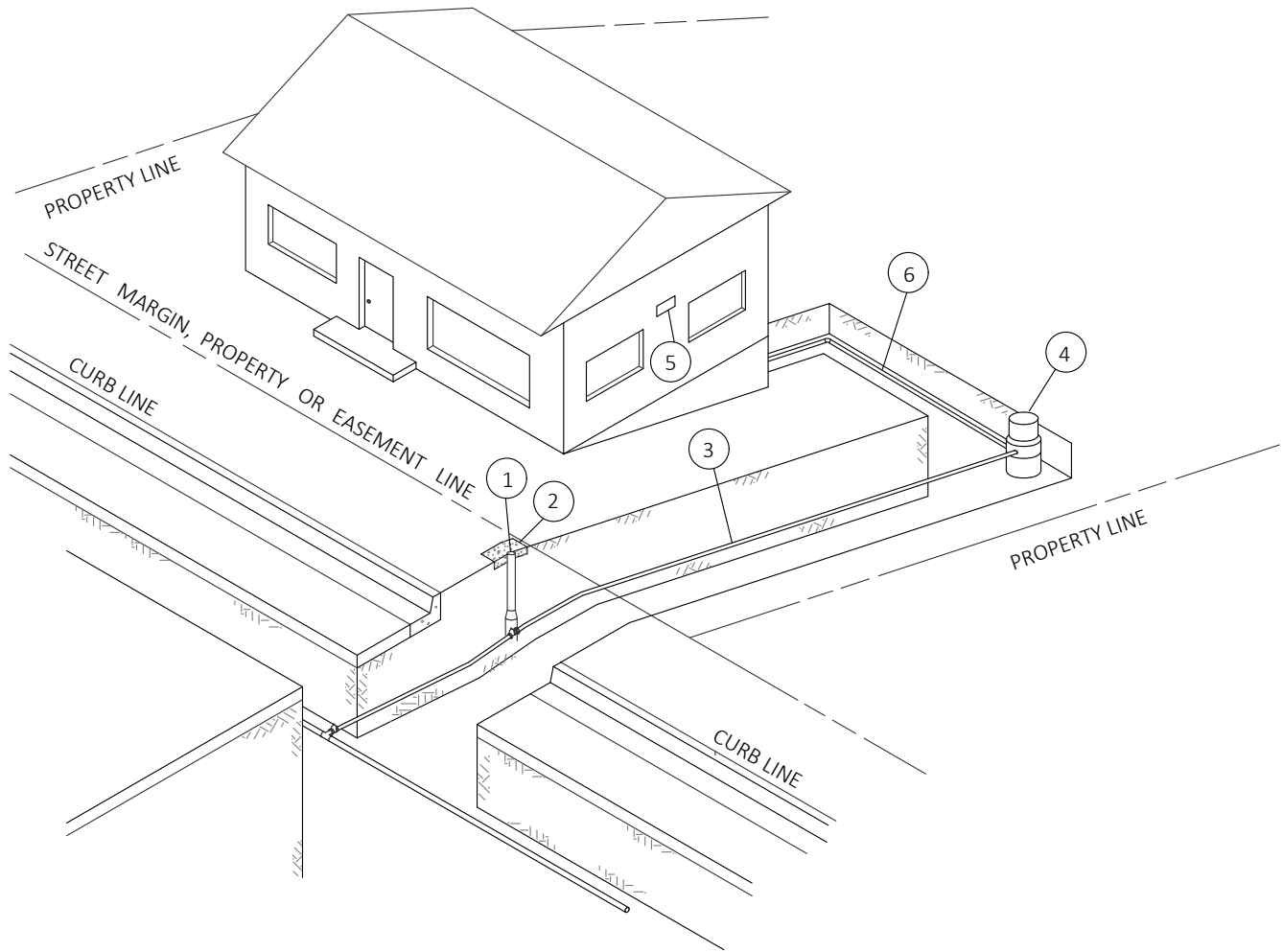

**NOTES:**

- ① CAST IRON VALVE BOX WITH LID MARKED "SEWER" SERIES 940B OR AS APPROVED BY CITY.
- ② INSTALL A 2 FOOT X 4 INCH THICK ASPHALT OR CONCRETE PAD AROUND THE VALVE BOX.
- ③ 1¼" HDPE ON-SITE SERVICE LINE WITH 16-GAUGE SOLID COPPER TRACER WIRE ALONG TOP OF HDPE FORCE MAIN AND WARNING TAPE MARKED "SEWER" 12" ABOVE LINE.
- ④ ENVIRONMENT ONE (OR APPROVED EQUAL) INDIVIDUAL GRINDER LIFT STATION, 70-150 GAL (TYP).
- ⑤ CONTROL PANEL SHALL BE MANUFACTURED BY ENVIRONMENT ONE OR ENGINEER-APPROVED EQUIVALENT. MOUNT CONTROL PANEL 3 TO 5 FEET FROM THE GROUND SURFACE WITHIN SIGHT OF THE PUMP BASIN LID. USE 1-INCH CONDUIT TO RUN UNSPLICED CONTROL WIRE BETWEEN PANEL AND PUMP. IF CABLE LONGER THAN 100 FT IS NEEDED AND SPLICING IS NECESSARY, CITY APPROVAL IS REQUIRED FOR SPECIAL SPLICING REQUIREMENTS. ALL CONTROL PANEL WIRING SHALL BE DONE ACCORDING TO MANUFACTURER'S WIRING DIAGRAM LOCATED INSIDE THE DOOR OF CONTROL PANEL.
- ⑥ GRAVITY HOUSE SERVICE TO GRINDER PUMP.
- ⑦ CONTACT THE CITY TO SCHEDULE AN ON-SITE PRECONSTRUCTION MEETING PRIOR TO BEGINNING ANY WORK.

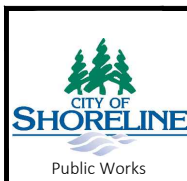

PUBLICATION DATE: **03/01/2024** REVISION DATE: **09/06/2023**

STANDARD DETAIL NUMBER: **639** SCALE: **NOT TO SCALE**

**HOUSE CONNECTION W-GRINDER  
PUMP TO GRAVITY MAIN - SANITARY**

**CONSTRUCTION REQUIREMENTS ( STUB SERVICE )**

(TO BE CONSTRUCTED BY CITY OR DEVELOPER AS PART OF THE PROJECT)

1. JOINTS MUST BE MADE W/RUBBER TYPE GASKET AS APPROVED BY CITY.
2. ALL STUB SERVICES SHALL BE TESTED IN ACCORDANCE WITH THE CITY'S SPECIFICATIONS PRIOR TO APPROVAL.
3. ALL MATERIALS USED IN THE CONSTRUCTION OF ANY STUB SERVICE SHALL HAVE PRIOR APPROVAL OF THE CITY.

**CONSTRUCTION REQUIREMENTS ( SIDE SEWER )**

(TO BE CONSTRUCTED BY PROPERTY OWNER AFTER COMPLETION OF PROJECT)

1. SIDE SEWER SHALL BE CONNECTED TO STUB SERVICE WITH A 6"x6"x6" CLEANOUT TO GRADE WITH LOCKING LID AND 6"x4" REDUCER, BY PROPERTY OWNER.
2. 4" MIN SEWER PIPE REQUIRED ON PROPERTY. PERMIT REQUIRED.
3. 6" MIN SEWER PIPE REQUIRED ON PROPERTY, FOR JOINT SIDE SEWERS. PERMIT AND JOINT SIDE SEWER EASEMENT AGREEMENT REQUIRED.
4. 2% MIN GRADE (1/4" FALL PER FOOT); 200% MAXIMUM GRADE (24" FALL PER FOOT).
5. JOINTS MUST BE MADE W/RUBBER TYPE GASKET, APPROVED BY CITY.
6. CONSTRUCTION ON PRIVATE PROPERTY MAY BE DONE BY OWNER, BUT REQUIRES A PERMIT.
7. ALL MATERIALS USED IN THE CONSTRUCTION OF ANY SIDE SEWER SHALL HAVE PRIOR APPROVAL OF CITY. PIPE TO BE CLASS 50 DUCTILE IRON, OR ASTM D-3034, SDR 35 PVC, OR SDR 11 HDPE FOR ALTERNATIVE SEWER SERVICE.
8. ALL SIDE SEWERS SHALL BE TESTED IN ACCORDANCE WITH THE CITY'S SPECIFICATIONS PRIOR TO APPROVAL BY CITY.
9. CONNECTIONS SHALL BE COMPLETE AT BOTH ENDS BEFORE CALLING FOR INSPECTION.
10. NO DOWNSPOUTS OR OUTSIDE DRAINS SHALL BE CONNECTED TO SANITARY SEWERS.
11. CLEAN-OUTS TO GRADE SHALL BE PROVIDED 18" MIN TO 30" MAXIMUM FROM BUILDING AND SPACED AT 100' (MAXIMUM) INTERVALS UNLESS APPROVED BY CITY.
12. ALL CONSTRUCTION OF SIDE SEWERS MUST COMPLY WITH CITY REGULATIONS.
13. TWO 45° BENDS WITH 24" MIN SEPARATION BETWEEN BENDS TO EQUAL 90° BEND.

**INDIVIDUAL LIFT STATION MATERIALS LIST**

1. SDR-11 1-1/4" HDPE PIPE, DR11-55.
2. TRACER WIRE (16 GAUGE SOLID COPPER), NO. W14BLK-500 OR EQUAL.
3. TRACER TAPE (MARKED SEWER) NO. WWTAPEDT-25.
4. 1-1/4" HDPE BUTT FUSED JOINT.
5. 6" MJ CAP TAPPED 1-1/4" OR 2" IP WITH MJ KIT NO. IFD2MX5L.
6. 2"x1-1/4" STAINLESS STEEL OR BRASS BUSHING.
7. IF PIPE IS 6" 3034 SEWER, A 6" MJ x PSM TRANSITION GASKET NO. IFGMPSMZ WILL BE REQUIRED.
8. 1-1/4" TRANSITION FITTING HDPE SDR11 x MIP 304SS (DRAS-5).
9. 2" BRASS SWING CHECK FIPxFIP (LEGEND VALVE T-451 OR EQUAL).

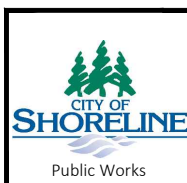

PUBLICATION DATE: <b>03/01/2024</b>	REVISION DATE: <b>09/06/2023</b>
STANDARD DETAIL NUMBER: <b>640</b>	SCALE: <b>NOT TO SCALE</b>

**HOUSE CONNECTION  
REQUIREMENTS - SANITARY**



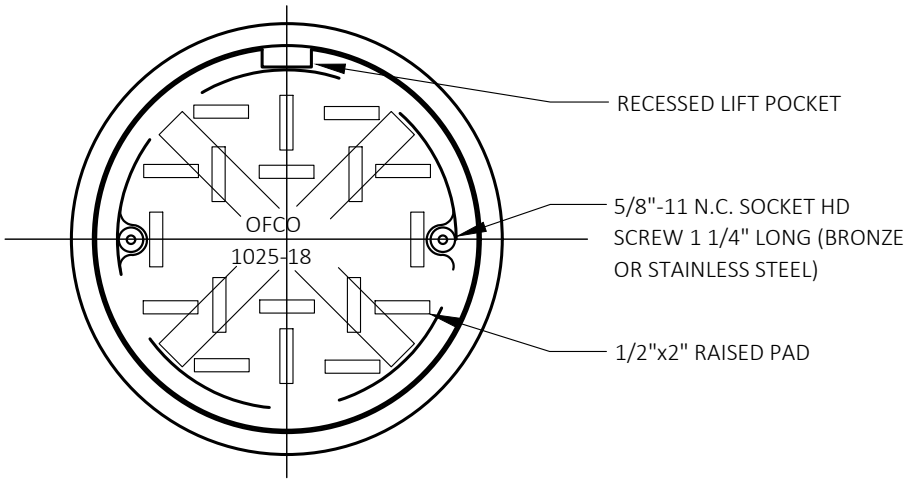

**PLAN**

NOTE:  
 IN SOFTSCAPE AND UNPAVED  
 USE CARSON MODEL 910-4  
 CLEANOUT COVER.

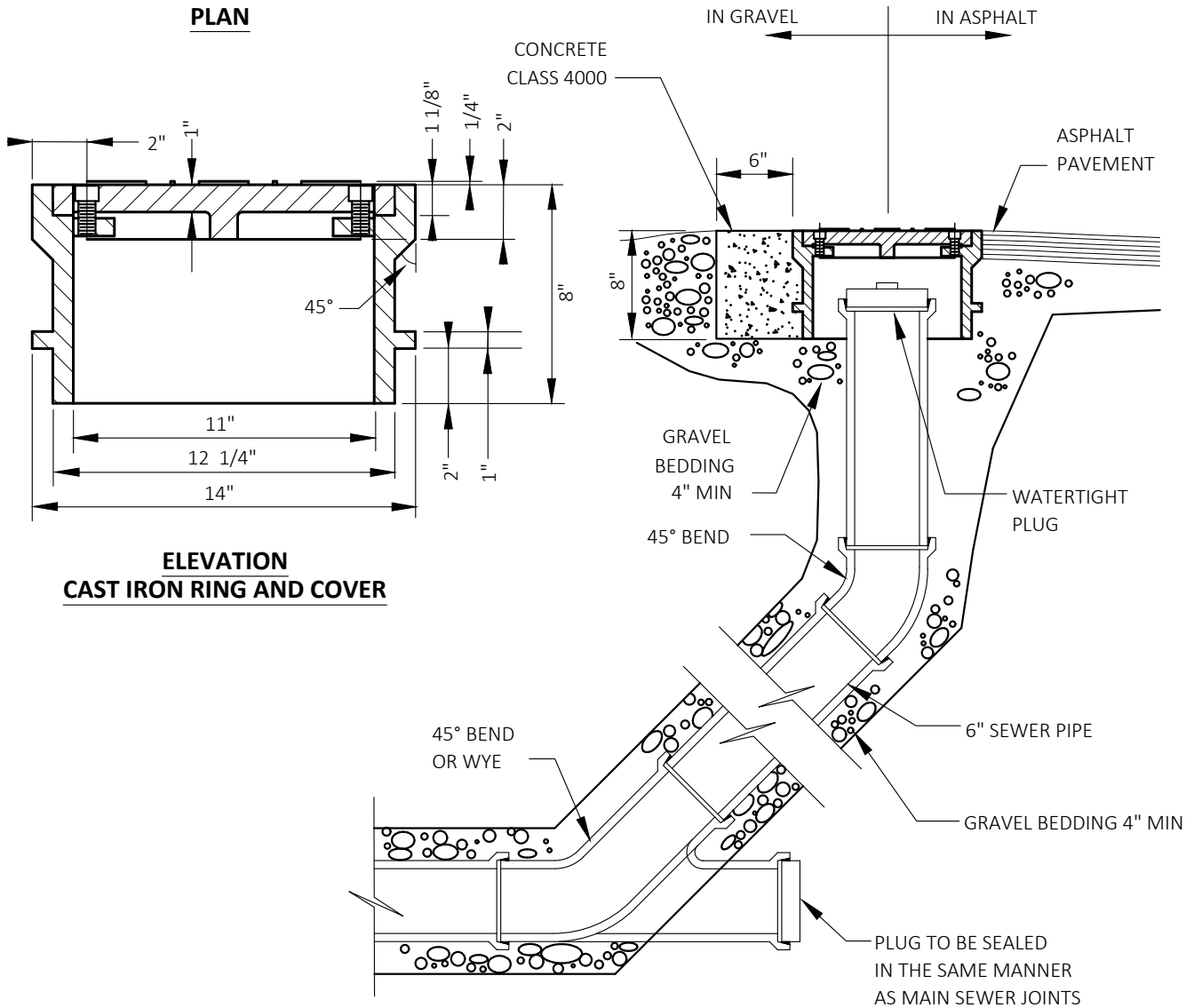

**ELEVATION  
 CAST IRON RING AND COVER**

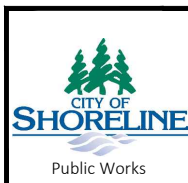

PUBLICATION DATE: **03/01/2024** REVISION DATE: **09/06/2023**

STANDARD DETAIL NUMBER: **641** SCALE: **NOT TO SCALE**

**SANITARY SEWER CLEANOUT  
 DETAIL**

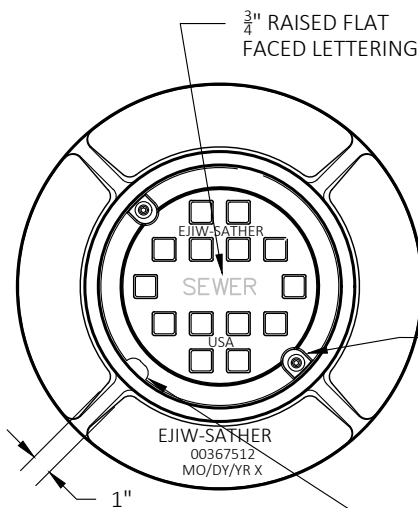

**PLAN**

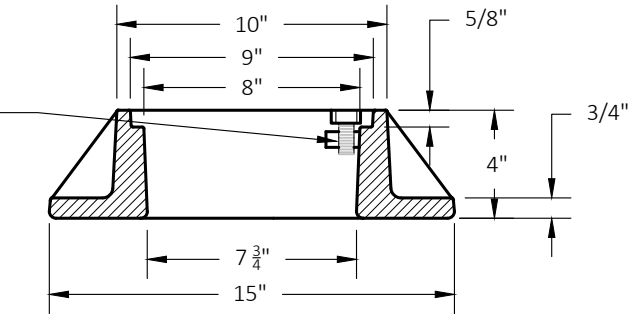
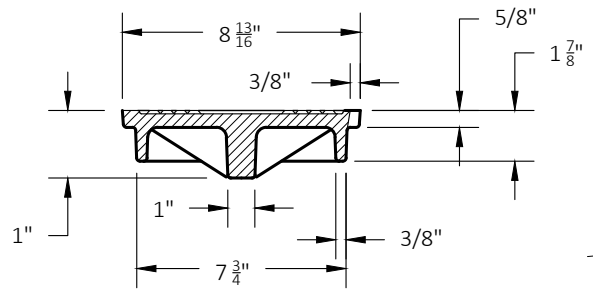

**ELEVATION CAST IRON RING AND COVER**

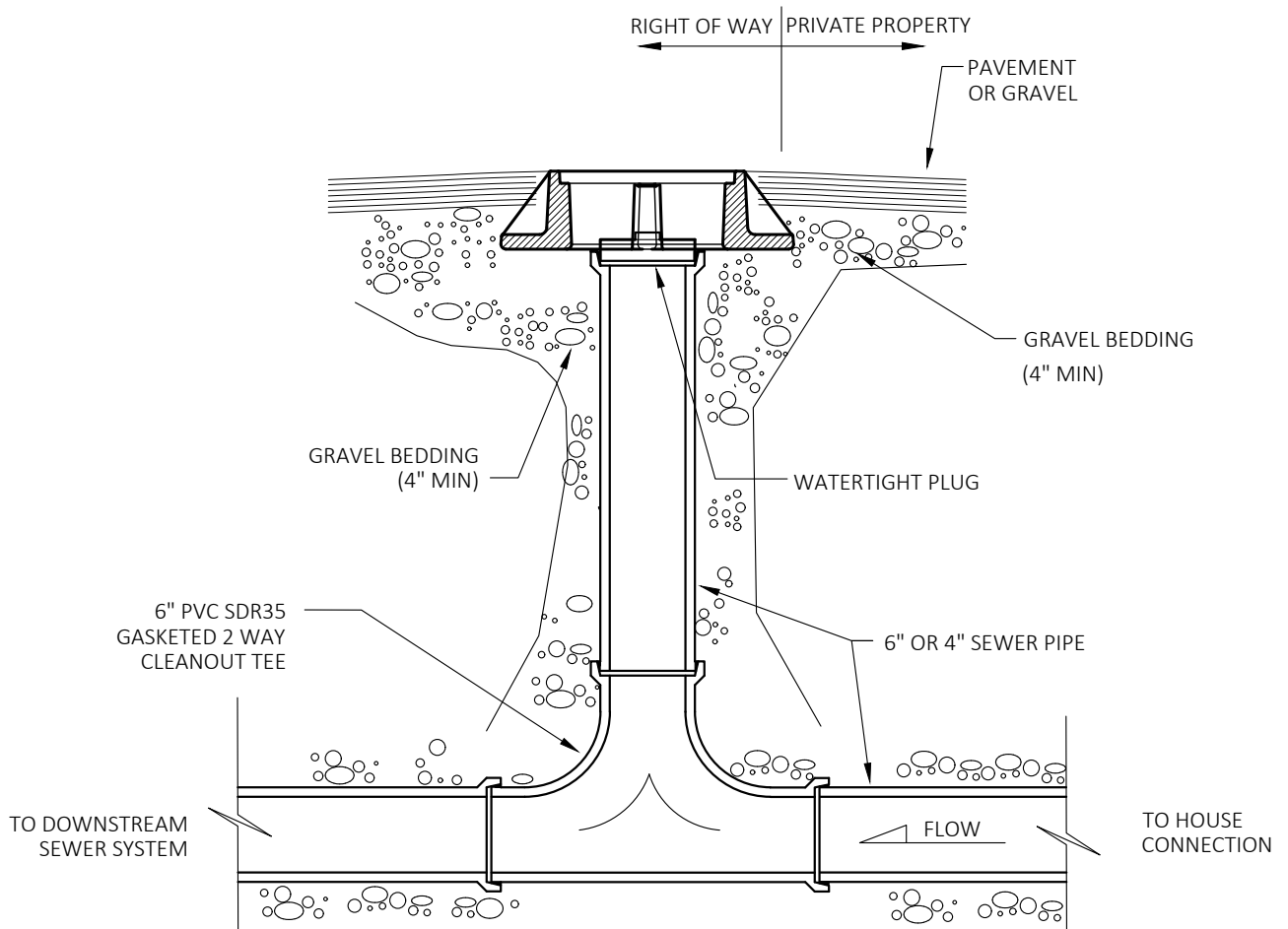

 CITY OF SHORELINE Public Works	PUBLICATION DATE: <b>03/01/2024</b>	REVISION DATE: <b>09/06/2023</b>
	STANDARD DETAIL NUMBER: <b>642</b>	SCALE: <b>NOT TO SCALE</b>
	<b>TWO WAY SEWER CLEANOUT AT PROPERTY LINE</b>	

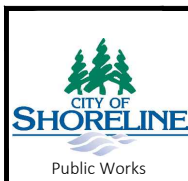
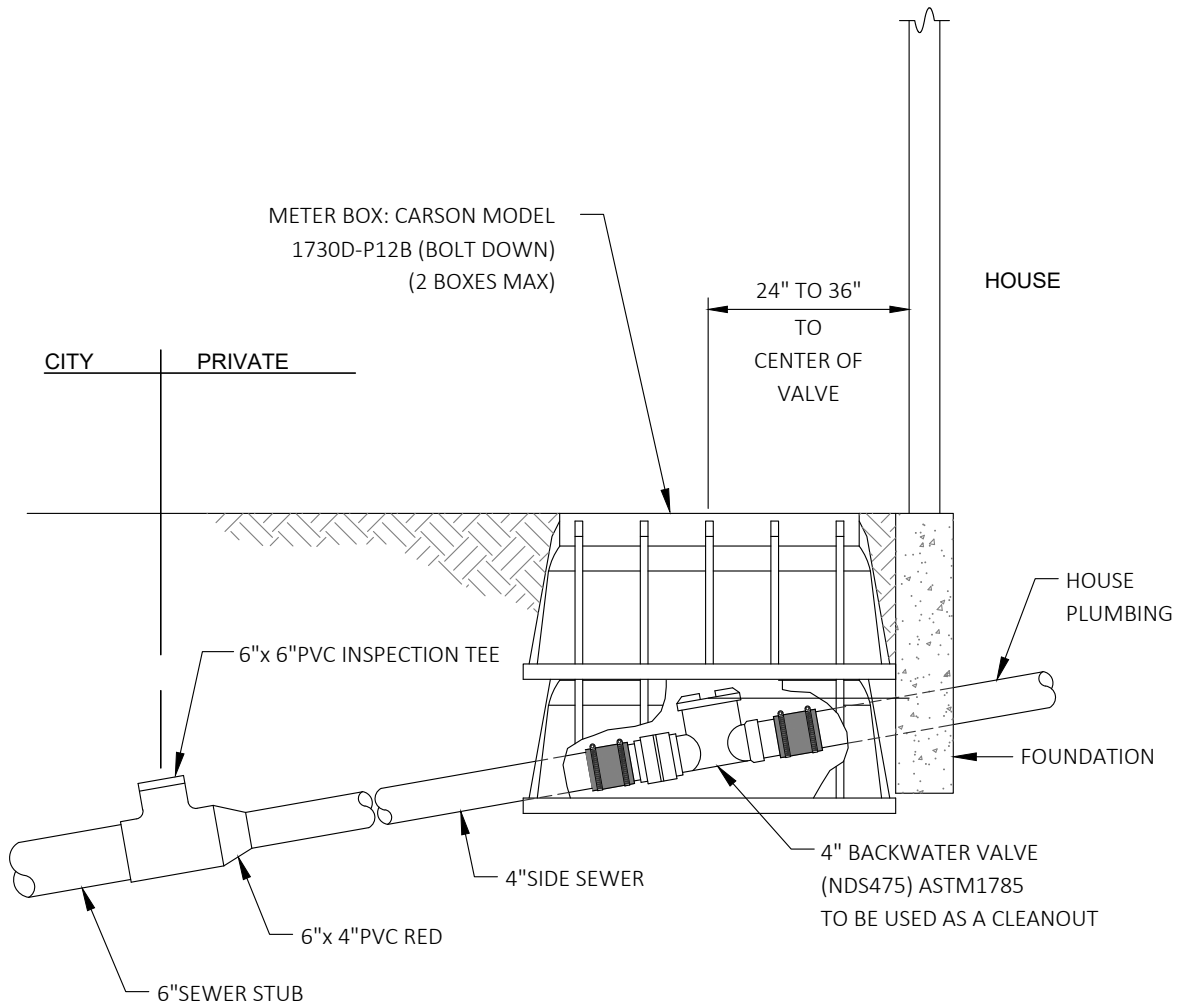
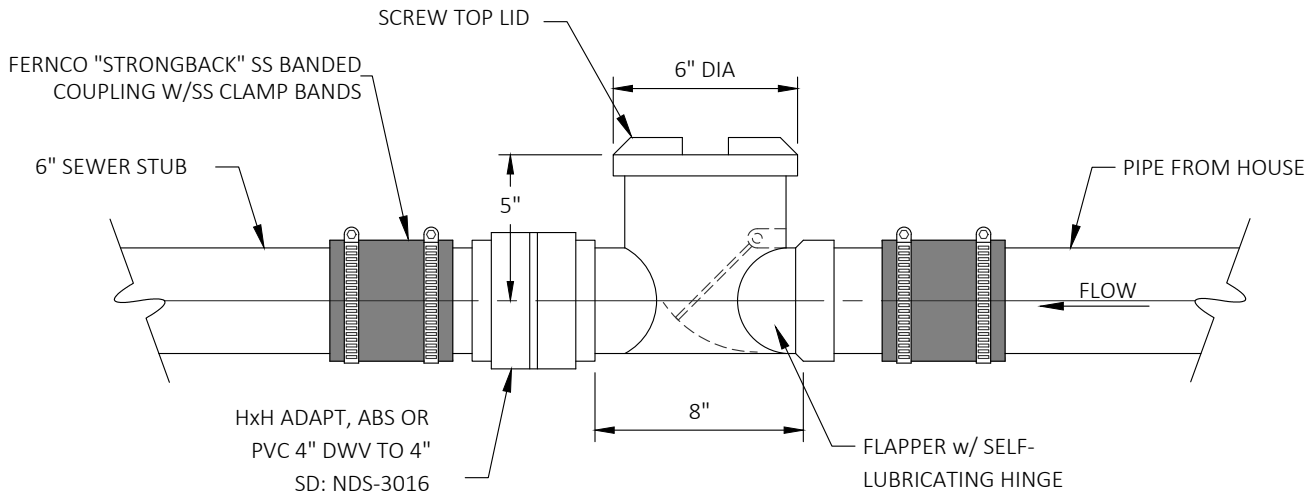

PUBLICATION DATE: <b>03/01/2024</b>	REVISION DATE: <b>09/06/2023</b>
STANDARD DETAIL NUMBER: <b>643</b>	SCALE: <b>NOT TO SCALE</b>

## BACKFLOW PREVENTER DETAIL - SANITARY

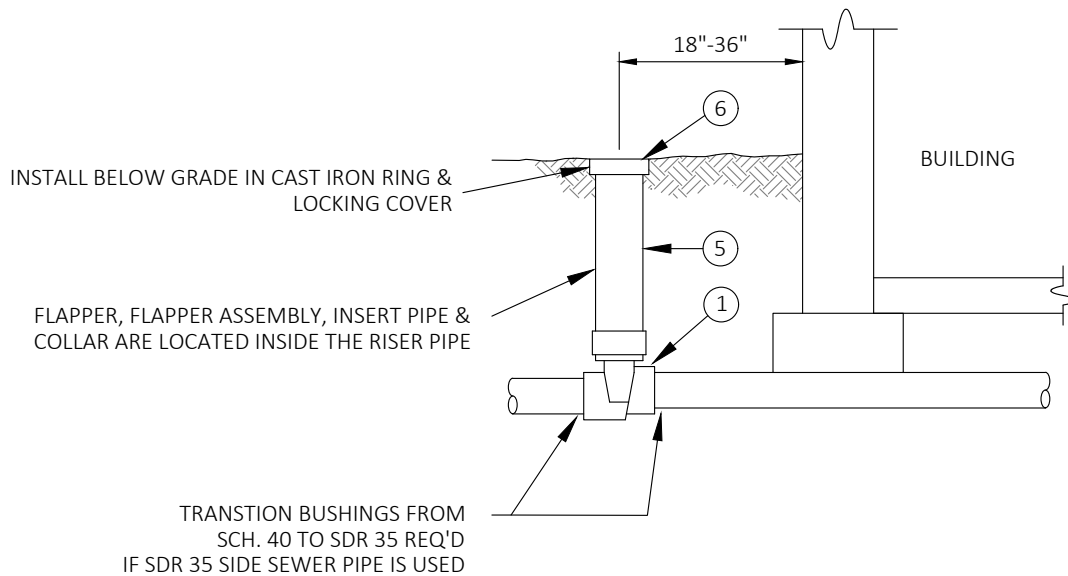

**MATERIAL LIST:**

- ① CLEAN CHECK INC. 4" OR 6" SHOE VALVE BODY.  
USE 4" VALVE FOR SINGLE FAMILY RESIDENTIAL.  
USE 6" VALVE BODY FOR MULTI-FAMILY AND COMMERCIAL.
- ② FLAPPER AND FLAPPER ASSEMBLY BY CLEAN CHECK INC.
- ③ COLLAR BY CLEAN CHECK INC.
- ④ 4" OR 6" PVC INSERT PIPE. USE 4" INSERT PIPE FOR 4" VALVE. USE 6" INSERT PIPE FOR 6" VALVE.  
CUT INSERT PIPE TO LENGTH PER SPECIFICATIONS.
- ⑤ 6" OR 8" PVC RISER PIPE. USE 6" RISER FOR 4" VALVE. USE 8" RISER FOR 6" VALVE. CUT TO LENGTH FOR BELOW GRADE INSTALLATION WITH CAST IRON RING AND LOCKING COVER OR TRAFFIC BEARING METER BOX.
- ⑥ 6" OR 8" THREAD BY HUB ADAPTER WITH THREADED PLUG. ADAPTER SHALL BE INSTALLED BELOW GRADE INSIDE A CAST IRON RING AND LOCKING COVER OR TRAFFIC BEARING METER BOX IN AREAS OF VEHICLE OR PEDESTRIAN TRAFFIC. SEE SURFACE CLEANOUT DETAIL FOR ADDITIONAL INFORMATION.

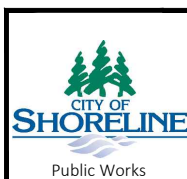
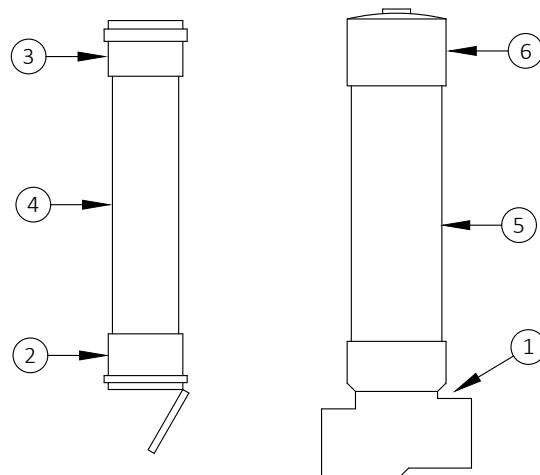

PUBLICATION DATE: <b>03/01/2024</b>	REVISION DATE: <b>09/06/2023</b>
STANDARD DETAIL NUMBER: <b>644</b>	SCALE: <b>NOT TO SCALE</b>

**BACKFLOW PREVENTER  
CLEANSWEEP DETAIL - SANITARY**

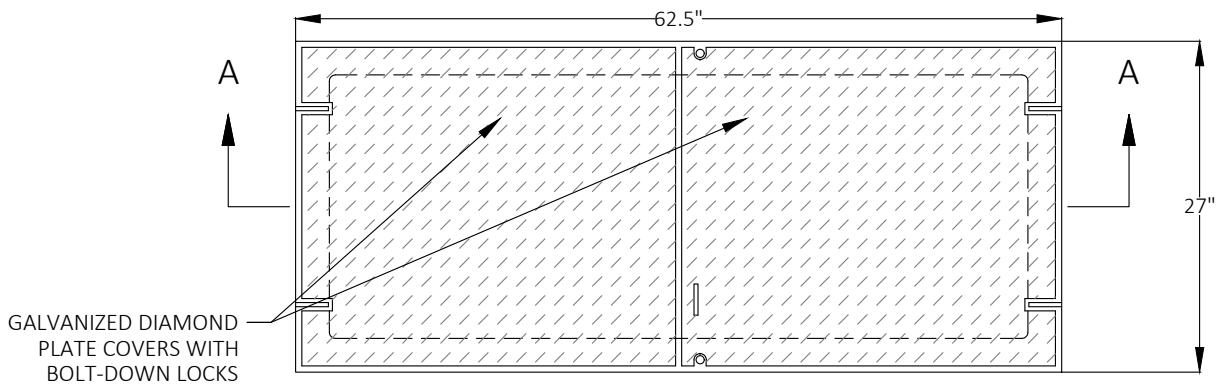

**COVER PLAN**

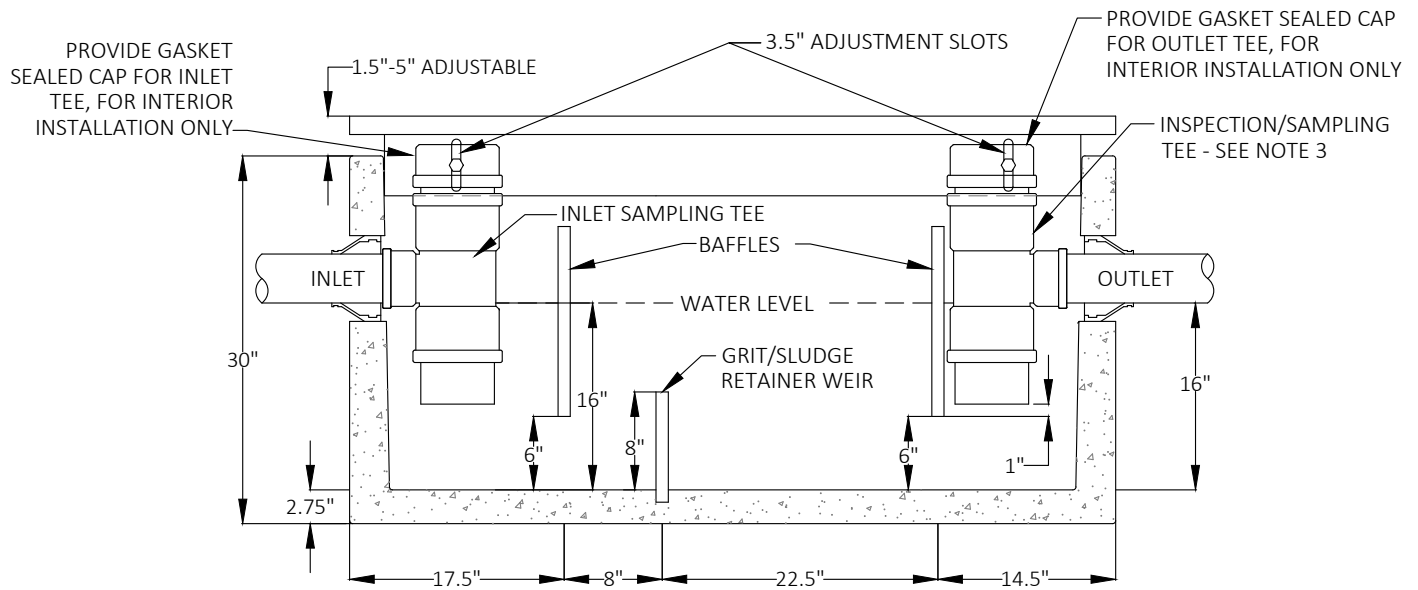

**SECTION A-A**

**NOTES:**

1. USE UTILITY VAULT COMPANY INC. MODEL #25-SA OR EQUAL. PRECAST VAULT SHALL HAVE KNOCKOUTS AT ALL PIPE OPENINGS. IF KNOCKOUTS ARE NOT PRESENT, THEN PIPE OPENINGS SHALL BE CORE-DRILLED. PIPE OPENINGS SHALL BE 2" LARGER THAN THE PIPE DIAMETER.
2. LOCATE VAULT WITHIN 20' OF DRIVE FOR ACCESS BY MAINTENANCE VEHICLES.
3. PVC INSPECTION AND SAMPLING TEE SHALL BE THE SAME SIZE AS THE OUTLET PIPE FOR 6" OUTLET OR GREATER. USE 6" BY OUTLET-SIZE TEE WHERE OUTLET PIPE SIZE IS LESS THAN 6". INSTALL GASKETED CAP ON TOP OF THE SAMPLING TEE, FOR INTERIOR INSTALLATION ONLY.
4. FILL WITH CLEAN WATER PRIOR TO START-UP OF THE SYSTEM.
5. BLACK WATER SHALL BE CARRIED BY SEPARATE SIDE SEWER AND NOT CONNECTED TO OIL/WATER SEPARATOR.
6. PIPE CONNECTION TO VAULT: KOR-N-SEAL OR EQUAL FOR CORE-DRILLED OPENINGS, OR SAND COLLAR FOR KNOCKOUT OPENING. SEAL ALL PIPE CONNECTIONS WITH NONSHRINK GROUT.
7. INTERIOR OIL/WATER SEPARATORS SHALL HAVE VENTING PER THE UNIFORM PLUMBING CODE.
8. PRIOR TO STARTUP, OIL/WATER SEPARATOR SHALL PASS 1% PER DAY LEAK TEST WHERE ONLY A MAXIMUM OF 1% OF OF DEAD STORAGE REDUCTION IS ALLOWED WITHIN A 24 HOUR PERIOD PER THE UNIFORM PLUMBING CODE.
9. ACCESS LID SHALL HAVE SLIP RESISTANT TREATMENT.



PUBLICATION DATE: <b>03/01/2024</b>	REVISION DATE: <b>09/06/2023</b>
STANDARD DETAIL NUMBER: <b>645</b>	SCALE: <b>NOT TO SCALE</b>

**SMALL OIL WATER SEPARATOR-  
SANITARY**

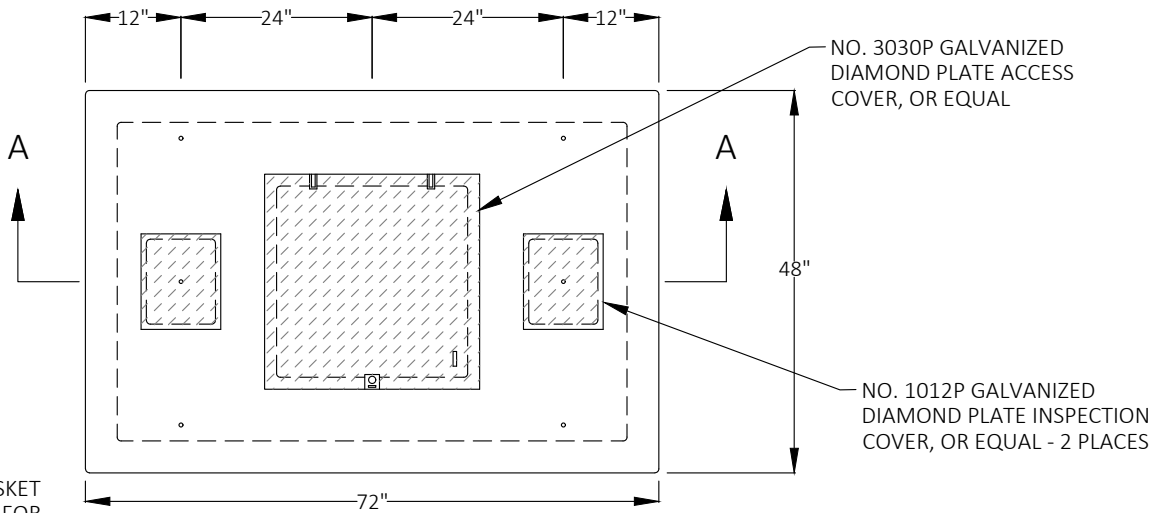

**COVER PLAN**

PROVIDE GASKET SEALED CAP FOR INLET TEE, FOR INTERIOR INSTALLATION ONLY

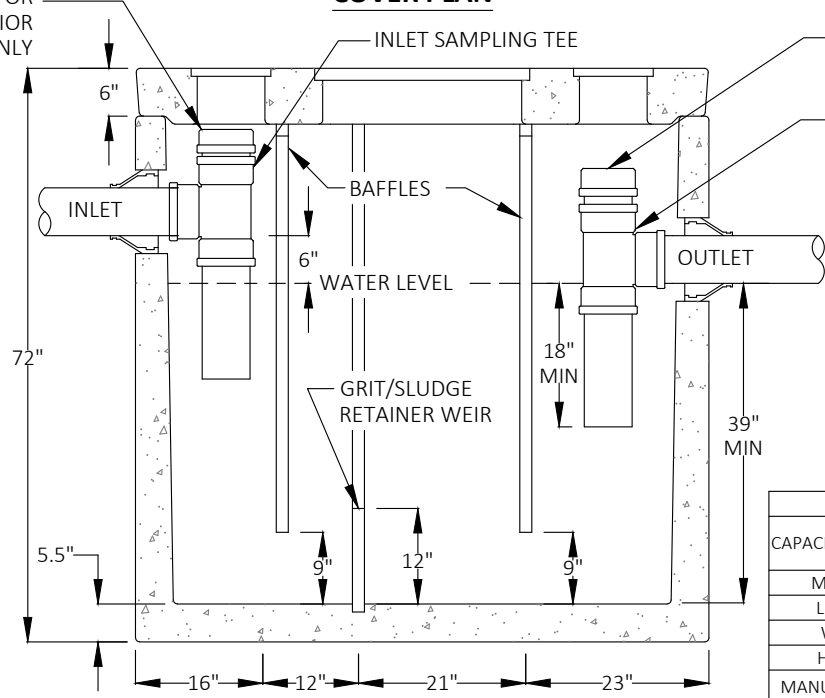

**SECTION A-A**

PROVIDE GASKET SEALED CAP FOR OUTLET TEE, FOR INTERIOR INSTALLATION ONLY

INSPECTION/SAMPLING TEE - SEE NOTE 3

VAULT CHART		
CAPACITY GALLONS	450	750-900
MODEL #	660-SA	577-SA
LENGTH	6'-0"	7'-0"
WIDTH	4'-0"	4'-8"
HEIGHT	6'-0"	7'-0"
MANUFACTURER	UV	UV

**NOTES:**

1. USE UTILITY VAULT COMPANY INC. MODELS (SEE CHART) OR EQUAL. PRECAST VAULT SHALL HAVE KNOCKOUTS AT ALL PIPE OPENINGS. IF KNOCKOUTS ARE NOT PRESENT, THEN PIPE OPENINGS SHALL BE CORE-DRILLED. PIPE OPENINGS SHALL BE 2" LARGER THAN THE PIPE DIAMETER.
2. LOCATE VAULT WITHIN 20' OF DRIVE FOR ACCESS BY MAINTENANCE VEHICLES.
3. P.V.C. INSPECTION AND SAMPLING TEE SHALL BE THE SAME SIZE AS THE OUTLET PIPE FOR 6" OUTLET OR GREATER. USE 6" P.V.C. TEE WHERE OUTLET PIPE SIZE IS LESS THAN 6". INSTALL GASKETED CAP ON TOP OF THE SAMPLING TEE, FOR INTERIOR INSTALLATIONS ONLY.
4. FILL WITH CLEAN WATER PRIOR TO START-UP OF THE SYSTEM.
5. BLACK WATER SHALL BE CARRIED BY SEPARATE SIDE SEWER AND NOT CONNECTED TO OIL/WATER SEPARATOR.
6. PIPE CONNECTION TO VAULT: KOR-N-SEAL OR EQUAL FOR CORE-DRILLED OPENINGS, OR SAND COLLAR FOR KNOCKOUT OPENING. SEAL ALL PIPE CONNECTIONS WITH NONSHRINK GROUT.
7. INTERIOR OIL/WATER SEPARATORS SHALL HAVE VENTING PER THE UNIFORM PLUMBING CODE.
8. PRIOR TO STARTUP, OIL/WATER SEPARATOR SHALL PASS 1% PER DAY LEAK TEST WHERE ONLY A MAXIMUM OF 1% OF DEAD STORAGE REDUCTION IS ALLOWED WITHIN A 24 HOUR PERIOD PER THE UNIFORM PLUMBING CODE.
9. ACCESS LIDS SHALL HAVE SLIP RESISTANT TREATMENT.

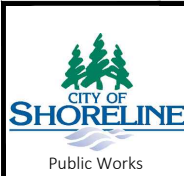

PUBLICATION DATE: **03/01/2024** REVISION DATE: **09/06/2023**

STANDARD DETAIL NUMBER: **646** SCALE: **NOT TO SCALE**

**MEDIUM OIL WATER SEPARATOR-SANITARY**

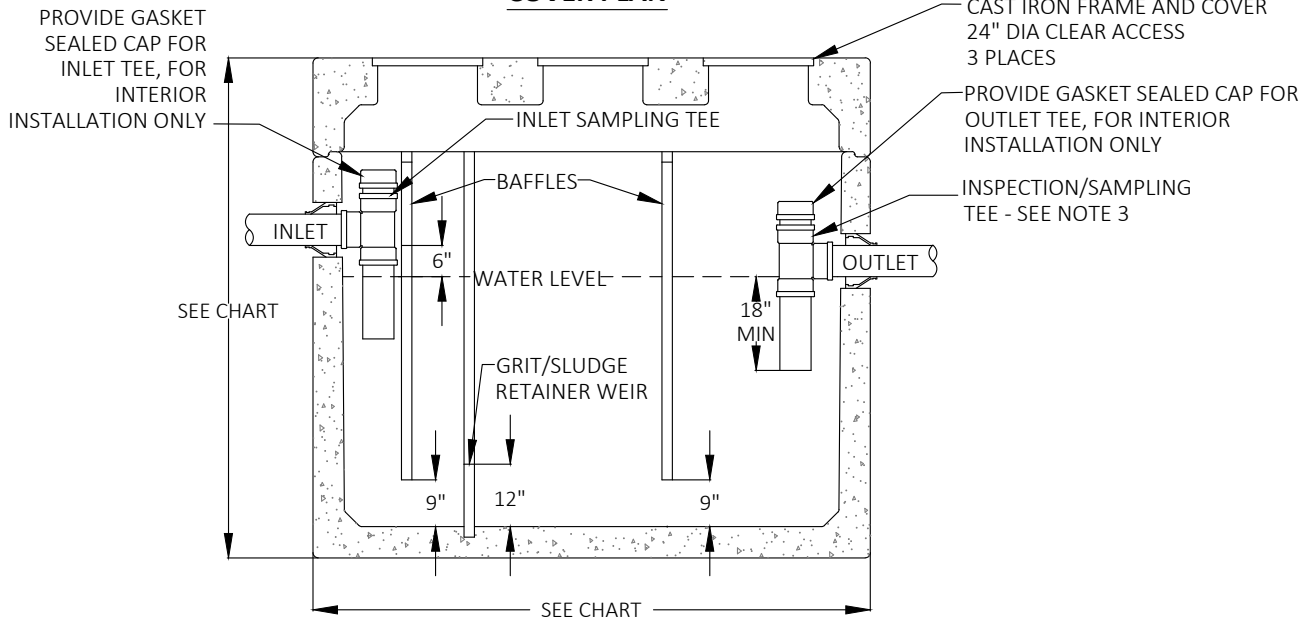
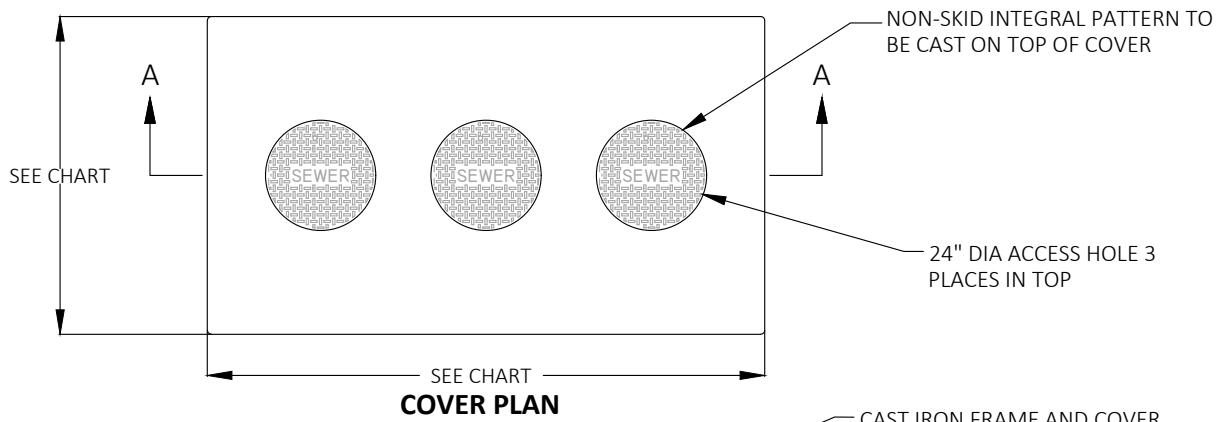

**SECTION A-A**

OIL/WATER SEPARATORS					
CAPACITY GALLONS	1100	1500	2200	3000- 4000	5000
MODEL #	4484-SA	5106-SA	612-SA	712-SA	814-SA
LENGTH	9'-0"	11'-2"	12'-8"	13'-1"	15'-7"
WIDTH	5'-0"	5'-8"	6'-8"	8'-0"	9'-7"
HEIGHT	7'-2½"	7'-2"	8'-0"	8'-7"	10'-½"
MANUFACTURER	UV	UV	UV	UV	UV

**NOTES:**

1. USE UTILITY VAULT COMPANY INC. MODEL (SEE CHART) OR EQUAL. PRECAST VAULT SHALL HAVE KNOCKOUTS AT ALL PIPE OPENINGS. IF KNOCKOUTS ARE NOT PRESENT, THEN PIPE OPENINGS SHALL BE CORE-DRILLED. PIPE OPENINGS SHALL BE 2" LARGER THAN THE PIPE DIAMETER.
2. LOCATE VAULT WITHIN 20' OF DRIVE FOR ACCESS BY MAINTENANCE VEHICLES.
3. PVC SAMPLING TEE SHALL BE THE SAME SIZE AS THE OUTLET PIPE FOR 6" OUTLET OR GREATER. USE 6" P.V.C. TEE WHERE OUTLET PIPE SIZE IS LESS THAN 6". INSTALL GASKETED CAP ON TOP OF THE SAMPLING TEE, FOR INTERIOR INSTALLATION ONLY.
4. FILL WITH CLEAN WATER PRIOR TO START-UP OF THE SYSTEM.
5. BLACK WATER SHALL BE CARRIED BY SEPARATE SIDE SEWER AND NOT CONNECTED TO OIL/WATER SEPARATOR.
6. PIPE CONNECTION TO VAULT: KOR-N-SEAL OR EQUAL FOR CORE-DRILLED OPENINGS, OR SAND COLLAR FOR KNOCKOUT OPENING. SEAL ALL PIPE CONNECTIONS WITH NONSHRINK GROUT.
7. INTERIOR OIL/WATER SEPARATORS SHALL HAVE VENTING PER THE UNIFORM PLUMBING CODE.
8. PRIOR TO STARTUP, OIL/WATER SEPARATOR SHALL PASS 1% PER DAY LEAK TEST WHERE ONLY A MAXIMUM OF 1% OF DEAD STORAGE REDUCTION IS ALLOWED WITHIN A 24 HOUR PERIOD PER THE UNIFORM PLUMBING CODE.

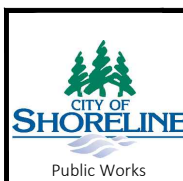

PUBLICATION DATE: **03/01/2024** REVISION DATE: **09/06/2023**

STANDARD DETAIL NUMBER: **647** SCALE: **NOT TO SCALE**

**LARGE OIL WATER SEPARATOR  
-SANITARY**

24" AIR AND GAS TIGHT BOLT-LOCKING RING AND COVER - 3 PLACES

RAISE CLEANOUT TO GRADE PER COS STD 645

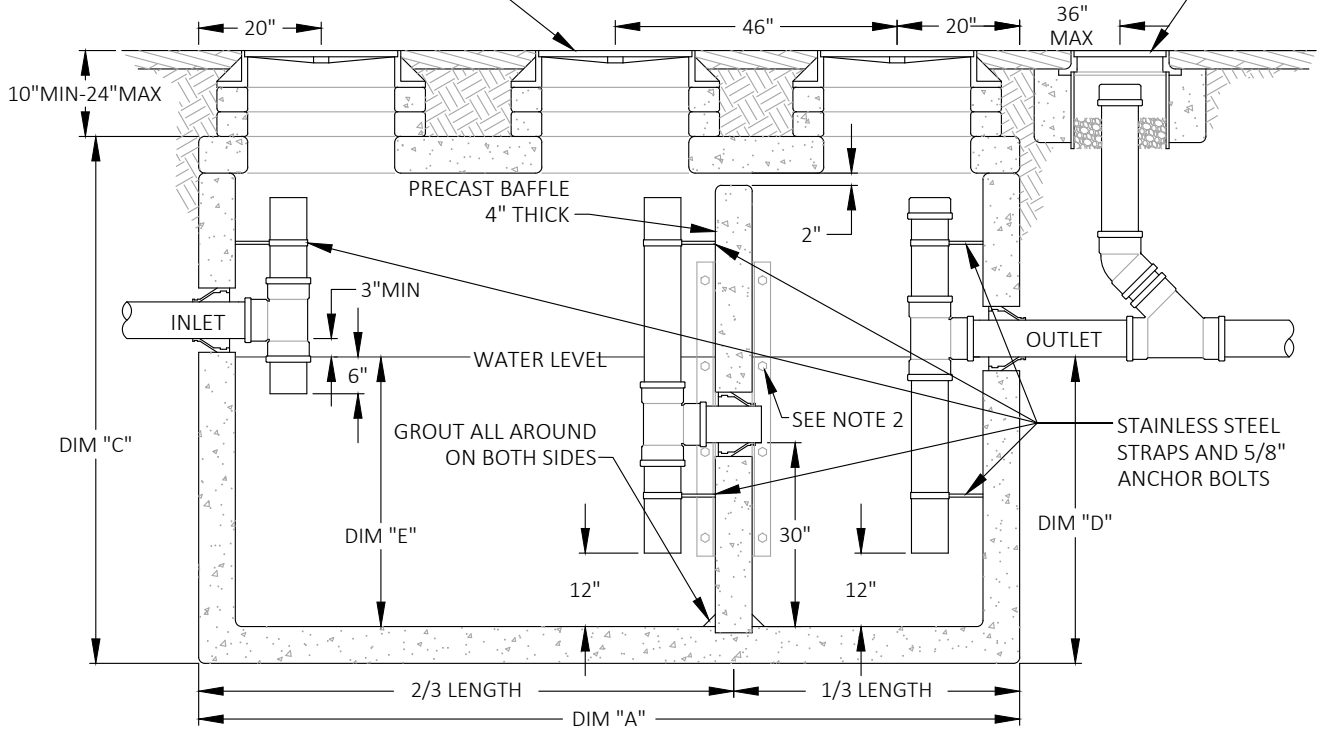

GALLON CAPACITY		600	750	1000	1500	2000	2500	3000	4000	5000	6000
UV CO. MODEL No.		577-GA	577-GA	4484-GA	5106-GA	612-GA	612-GA	712-GA	712-GA	818-GA	818-GA
LENGTH	DIM "A"	7'-0"	7'-0"	9'-0"	11'-2"	12'-8"	12'-8"	15'-7"	15'-7"	19'-11"	19'-11"
WIDTH	DIM "B"	4'-8"	4'-8"	5'-0"	5'-8"	6'-8"	6'-8"	9'-7"	9'-7"	9'-11"	9'-11"
HEIGHT	DIM "C"	7'-0"	7'-0"	7'-2"	7'-2"	8'-0"	8'-0"	8'-6 1/2"	8'-6 1/2"	8'-11"	10'-5"
	DIM "D"	3'-6"	4'-3"	4'-2"	4'-4"	4'-7"	5'-6"	5'-0"	6'-3"	6'-2"	7'-2"
WATER DEPTH	DIM "E"	3'-2"	3'-11"	3'-10"	4'-0"	3'-10"	4'-9"	3'-9"	5'-0"	4'-9"	5'-9"

**NOTES:**

- USE UTILITY VAULT COMPANY INC. PRECAST CONCRETE VAULT OR EQUAL. SEE CHART ABOVE FOR DIMENSIONS REQUIRED FOR EACH GALLON CAPACITY. PRECAST VAULT SHALL HAVE KNOCKOUTS AT ALL PIPE OPENINGS. IF KNOCKOUTS ARE NOT PRESENT, THEN PIPE OPENINGS SHALL BE CORE-DRILLED. PIPE OPENINGS SHALL BE 2" LARGER THAN THE PIPE DIAMETER.
- IF VAULT IS NOT SLOTTED TO ACCEPT PRECAST CONCRETE BAFFLE THEN BAFFLE SHALL BE HELD IN PLACE BY (2) 3"x3"x3/8" ANGLE 4FT LONG ON EACH SIDE. ALL 4 PIECES OF ANGLE SHALL BE HELD IN PLACE WITH 4 - 1/2" BOLTS WITH WASHERS SPACED 14" ON CENTER. ANGLE AND FASTENERS SHALL BE STAINLESS STEEL OR GALVANIZED AND ASPHALT COATED.
- LOCATE VAULT WITHIN 20' OF DRIVE FOR ACCESS BY MAINTENANCE VEHICLES.
- PVC INSPECTION AND SAMPLING TEE SHALL BE THE SAME SIZE AS THE OUTLET PIPE FOR 6" OUTLET OR GREATER. USE 6" PVC TEE WHERE OUTLET PIPE SIZE IS LESS THAN 6". INSTALL GASKETED CAP ON TOP OF THE SAMPLING TEE.
- POSITION RISERS BELOW ACCESS OPENINGS TO ALLOW CLEAR ACCESS TO RISER AND VAULT CHAMBER.
- ALL RINGS AND COVERS SHALL BE AIR AND GAS TIGHT BOLT-LOCKING TYPE, RATED FOR H2O LOAD MIN.
- FOR 1000 GALLON INTERCEPTOR, SUBSTITUTE 12" RING AND COVER FOR "CENTER MANHOLE". LOCATE 12" RING AND COVER DIRECTLY ABOVE TEE AND RISER.
- FOR 600 AND 700 GALLON INTERCEPTOR, SUBSTITUTE 30" RING AND COVER FOR THE TWO 24" MANHOLES LOCATED AT THE OUTLET END OF THE VAULT. CENTER OF 30" RING AND COVER SHALL BE LOCATED 2 FT FROM THE OUTLET FACE OF VAULT.
- FILL WITH CLEAN WATER PRIOR TO START-UP OF THE SYSTEM.
- GRAY WATER ONLY. BLACK WATER SHALL BE CARRIED BY SEPARATE SIDE SEWER.
- PIPE CONNECTION TO VAULT: KOR-N-SEAL OR EQUAL FOR CORE-DRILLED OPENINGS, OR SAND COLLAR FOR KNOCKOUT OPENING. SEAL ALL PIPE CONNECTIONS WITH NONSHRINK GROUT.
- INTERIOR GREASE INTERCEPTORS SHALL HAVE VENTING PER THE UNIFORM PLUMBING CODE.
- PRIOR TO STARTUP, GREASE INTERCEPTOR SHALL PASS 1% PER DAY LEAK TEST WHERE ONLY A MAXIMUM OF 1% OF DEAD STORAGE REDUCTION IS ALLOWED WITHIN A 24 HOUR PERIOD PER THE UNIFORM PLUMBING CODE.

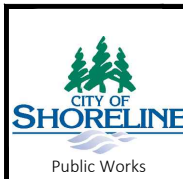

PUBLICATION DATE: **03/01/2024** REVISION DATE: **09/06/2023**

STANDARD DETAIL NUMBER: **648** SCALE: **NOT TO SCALE**

**GREASE INTERCEPTOR DETAIL-SANITARY**



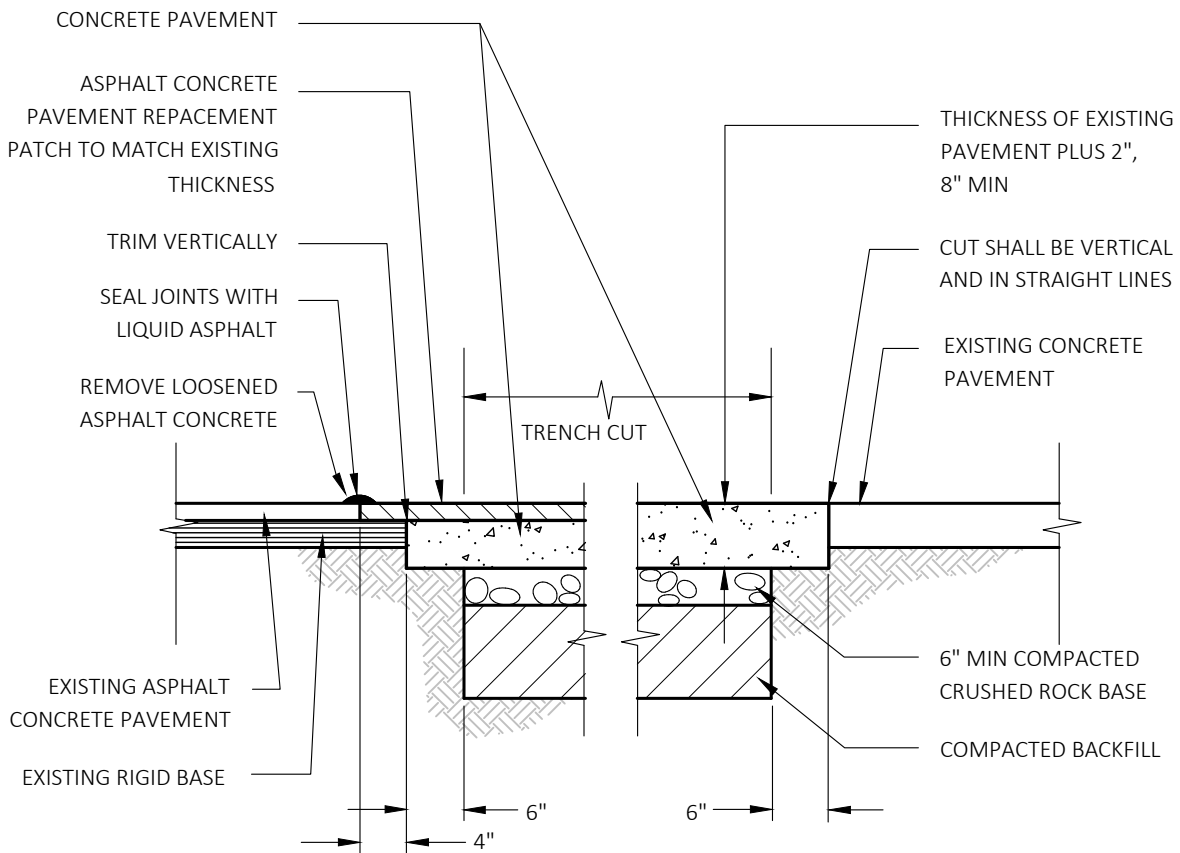

**RIGID PAVEMENT WITH ASPHALTIC CONCRETE SURFACE**

**CEMENT CONCRETE PAVEMENT**

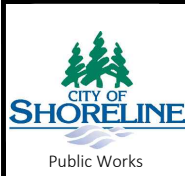

PUBLICATION DATE: <b>03/01/2024</b>	REVISION DATE: <b>09/06/2023</b>
STANDARD DETAIL NUMBER: <b>649</b>	SCALE: <b>NOT TO SCALE</b>

**RIGID PAVEMENT PATCHING**