

REINFORCING STEEL			
FOR SEPARATE BASES		FOR PRECAST BASE & INTEGRAL RISER	
DIA	SQ IN/FT	DIA	SQ IN/FT
48"	0.23	48"	0.15
54"	0.19	54"	0.19
60"	0.25	60"	0.25

**NOTES:**

- MANHOLES SHALL BE CONSTRUCTED IN ACCORDANCE WITH AASHTO M199 UNLESS OTHERWISE SHOWN ON PLANS OR NOTED IN THE WSDOT/APWA STANDARD SPECIFICATIONS.
- HANDHOLDS IN ADJUSTMENT SECTION SHALL HAVE 3" MIN CLEARANCE. STEPS IN MANHOLE SHALL HAVE 6" MIN CLEARANCE. SEE COS STD 606. HANDHOLDS SHALL BE PLACED IN ALTERNATING GRADE RINGS OR LEVELING BRICK COURSE WITH A MIN OF ONE HAND HOLD BETWEEN THE LAST STEP AND THE TOP OF THE MANHOLE.
- ALL REINFORCED CAST-IN-PLACE CONCRETE SHALL BE CLASS 4000. ALL PRECAST CONCRETE SHALL BE CLASS 4000. NON-REINFORCED CONCRETE IN CHANNEL AND SHELF SHALL BE CLASS 3000.
- PRECAST BASES SHALL BE FURNISHED WITH CUTOUTS OR KNOCKOUTS. KNOCKOUTS SHALL HAVE WALL THICKNESS OF 2" MIN. UNUSED KNOCKOUTS NEED NOT BE GROUTED IF WALL IS LEFT INTACT. PIPES SHALL BE INSTALLED ONLY IN FACTORY KNOCKOUTS UNLESS OTHERWISE APPROVED BY THE ENGINEER.
- KNOCKOUT OR CUTOUT HOLE SIZE SHALL EQUAL PIPE OUTER DIA PLUS MANHOLE WALL THICKNESS. MAX. HOLE SIZE SHALL BE 36" FOR 48" MANHOLE, 42" FOR 54" MANHOLE, 48" FOR 60" MH MIN DISTANCE BETWEEN HOLES SHALL BE 8".
- MANHOLE RINGS AND COVERS SHALL MEET THE STRENGTH REQUIREMENTS OF FEDERAL SPECIFICATION A-A-60005. MATING SURFACES SHALL BE FINISHED TO ASSURE NON-ROCKING FIT WITH ANY COVER POSITION.
- ALL BASE REINFORCING STEEL SHALL HAVE A MIN YIELD STRENGTH OF 60,000 PSI AND BE PLACED IN THE UPPER HALF OF THE BASE WITH 1" MIN AND 2.5" MAX CLEARANCE.
- FOR HEIGHTS OF 12' OR LESS, MIN SOIL BEARING VALUE SHALL EQUAL 3,300 POUNDS PER SQUARE FOOT. FOR HEIGHTS OVER 12', MIN SOIL BEARING VALUE SHALL EQUAL 3,800 POUNDS PER SQUARE FOOT.
- FOR DETAILS SHOWING GRADE RING, LADDER, STEPS, HANDHOLDS, AND TOP SLABS, SEE COS STD 606.
- SEE WSDOT STANDARD SPECIFICATIONS SEC 7-05.3 FOR JOINT REQUIREMENTS.

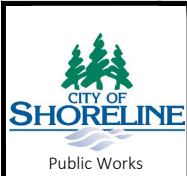

PUBLICATION DATE: <b>3/1/2022</b>	REVISION DATE: <b>4/30/2021</b>
STANDARD DETAIL NUMBER: <b>601</b>	SCALE: <b>NOT TO SCALE</b>

**MANHOLE TYPE I - SANITARY**

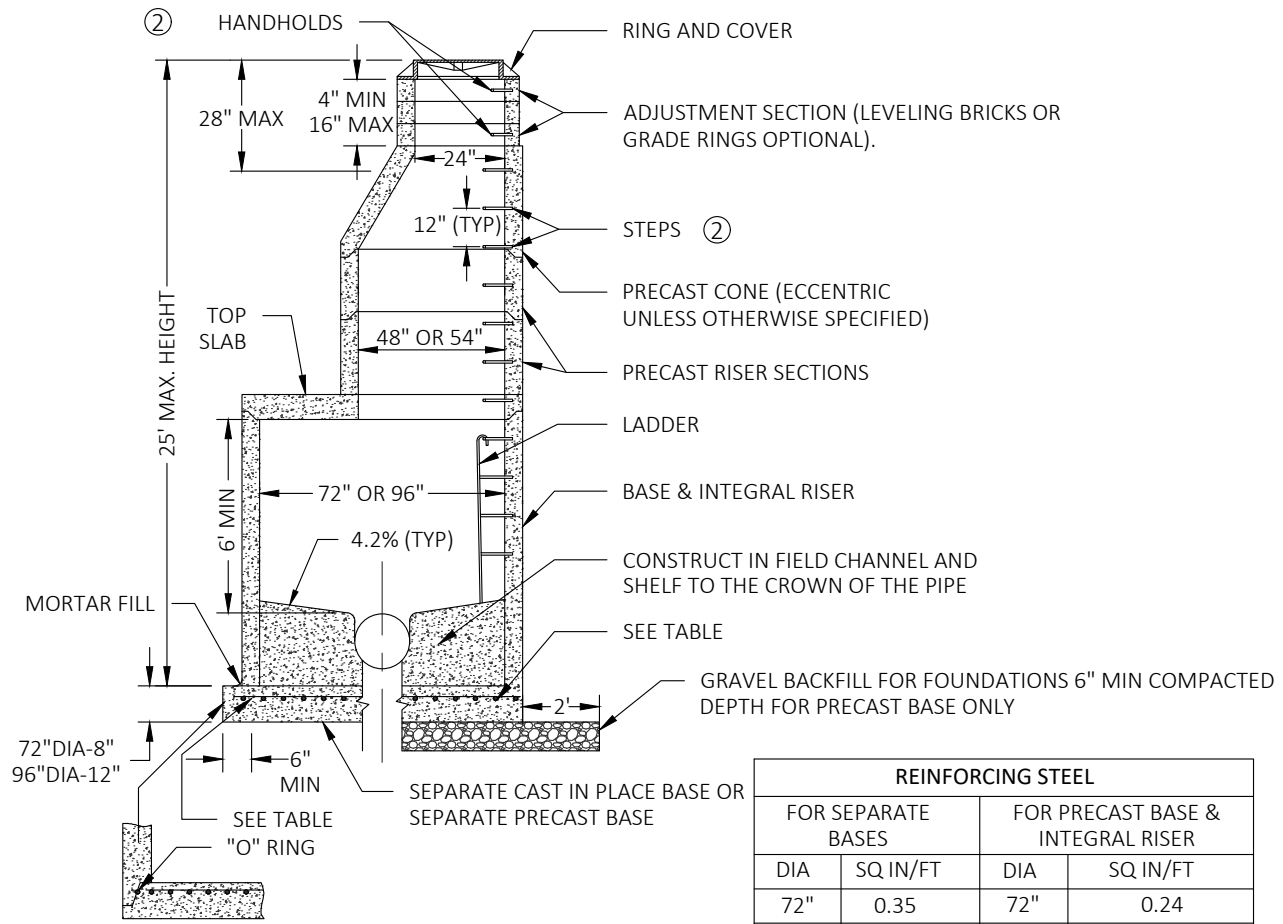

REINFORCING STEEL			
FOR SEPARATE BASES		FOR PRECAST BASE & INTEGRAL RISER	
DIA	SQ IN/FT	DIA	SQ IN/FT
72"	0.35	72"	0.24
96"	0.39	96"	0.29

**NOTES: PRECAST BASE JOINT**

- MANHOLES SHALL BE CONSTRUCTED IN ACCORDANCE WITH AASHTO M199 UNLESS OTHERWISE SHOWN ON PLANS OR NOTED IN THE WSDOT/APWA STANDARD SPECIFICATIONS.
- HANDHOLDS IN ADJUSTMENT SECTION SHALL HAVE 3" MIN. CLEARANCE. STEPS IN MANHOLE SHALL HAVE 6" MIN CLEARANCE. SEE COS STD 606, "MANHOLE DETAILS." HANDHOLDS SHALL BE PLACED IN ALTERNATING GRADE RINGS OR LEVELING BRICK COURSE WITH A MIN OF ONE HAND HOLD BETWEEN THE LAST STEP AND THE TOP OF THE MANHOLE.
- ALL REINFORCED CAST-IN-PLACE CONCRETE SHALL BE CLASS 4000. ALL PRECAST CONCRETE SHALL BE CLASS 4000. NON-REINFORCED CONCRETE IN CHANNEL AND SHELF SHALL BE CLASS 3000.
- PRECAST BASES SHALL BE FURNISHED WITH CUTOUTS OR KNOCKOUTS. KNOCKOUTS SHALL HAVE WALL THICKNESS OF 2" MIN. UNUSED KNOCKOUTS NEED NOT BE GROUTED IF WALL IS LEFT INTACT. PIPES SHALL BE INSTALLED ONLY IN FACTORY KNOCKOUTS UNLESS OTHERWISE APPROVED BY THE ENGINEER.
- KNOCKOUT OR CUTOUT HOLE SIZE SHALL EQUAL PIPE OUTER DIA PLUS MANHOLE WALL THICKNESS. MAX HOLE SIZE SHALL BE 60" FOR 72" MANHOLE, 84" FOR 96" MANHOLE. MIN DISTANCE BETWEEN HOLES SHALL BE 12".
- MANHOLE RINGS AND COVERS SHALL MEET THE STRENGTH REQUIREMENTS OF FEDERAL SPECIFICATION A-A-60005. MATING SURFACES SHALL BE FINISHED TO ASSURE NON-ROCKING FIT WITH ANY COVER POSITION.
- ALL BASE REINFORCING STEEL SHALL HAVE A MIN YIELD STRENGTH OF 60,000 PSI AND BE PLACED IN THE UPPER HALF OF THE BASE WITH 1" MIN. AND 2.5" MAX CLEARANCE.
- FOR HEIGHTS OF 12' OR LESS, MIN SOIL BEARING VALUE SHALL EQUAL 3,300 POUNDS PER SQUARE FOOT. FOR HEIGHTS OVER 12', MIN SOIL BEARING VALUE SHALL EQUAL 3,800 POUNDS PER SQUARE FOOT.
- FOR DETAILS SHOWING GRADE RING, LADDER, STEPS, HANDHOLDS, AND TOP SLABS, SEE COS STD 606, "MANHOLE DETAILS".
- SEE WSDOT STANDARD SPECIFICATIONS SEC 7-05.3 FOR JOINT REQUIREMENTS.

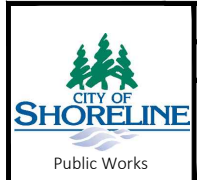

PUBLICATION DATE: <b>3/1/2022</b>	REVISION DATE: <b>4/30/2021</b>
STANDARD DETAIL NUMBER: <b>602</b>	SCALE: <b>NOT TO SCALE</b>

**MANHOLE TYPE II- SANITARY**

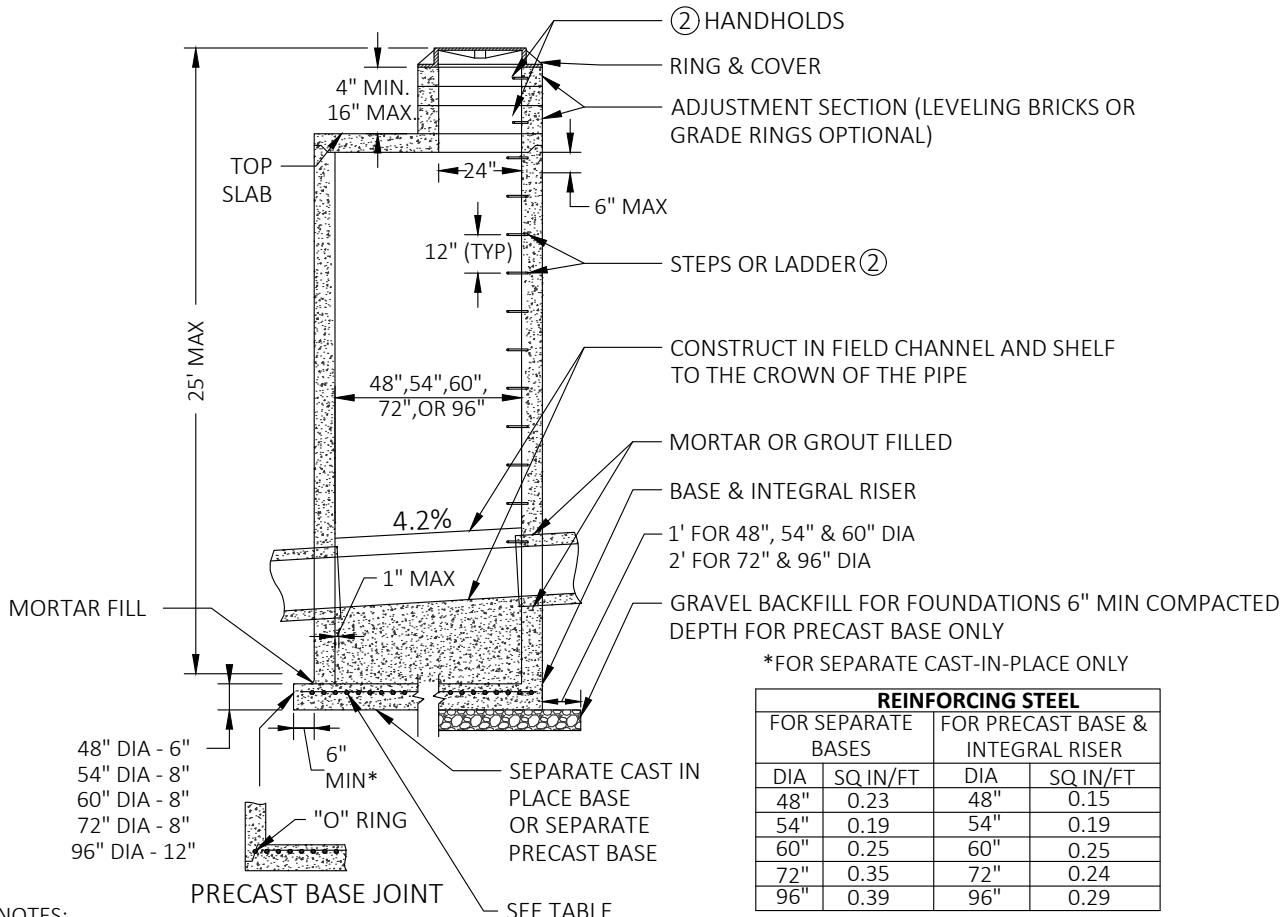

REINFORCING STEEL			
FOR SEPARATE BASES		FOR PRECAST BASE & INTEGRAL RISER	
DIA	SQ IN/FT	DIA	SQ IN/FT
48"	0.23	48"	0.15
54"	0.19	54"	0.19
60"	0.25	60"	0.25
72"	0.35	72"	0.24
96"	0.39	96"	0.29

**NOTES:**

- MANHOLES SHALL BE CONSTRUCTED IN ACCORDANCE WITH AASHTO M199 UNLESS OTHERWISE SHOWN ON PLANS OR NOTED IN THE WSDOT/APWA STANDARD SPECIFICATIONS.
- HANDHOLDS IN ADJUSTMENT SECTION SHALL HAVE 3" MIN. CLEARANCE. STEPS IN MANHOLE SHALL HAVE 6" MIN CLEARANCE. SEE COS STD 716, "MANHOLE DETAILS" HANDHOLDS SHALL BE PLACED IN ALTERNATING GRADE RINGS OR LEVELING BRICK COURSE WITH A MIN OF ONE HAND HOLD BETWEEN THE LAST STEP AND THE TOP OF THE MANHOLE
- ALL REINFORCED CAST-IN-PLACE CONCRETE SHALL BE CLASS 4000. ALL PRECAST CONCRETE SHALL BE CLASS 4000. NON-REINFORCED CONCRETE IN CHANNEL AND SHELF SHALL BE CLASS 3000.
- PRECAST BASES SHALL BE FURNISHED WITH CUTOUTS OR KNOCKOUTS. KNOCKOUTS SHALL HAVE WALL THICKNESS OF 2" MIN UNUSED KNOCKOUTS NEED NOT BE GROUTED IF WALL IS LEFT INTACT. PIPES SHALL BE INSTALLED ONLY IN FACTORY KNOCKOUTS UNLESS OTHERWISE APPROVED BY THE ENGINEER.
- KNOCKOUT OR CUTOUT HOLE SIZE SHALL EQUAL PIPE OUTER DIA PLUS MANHOLE WALL THICKNESS. MAX HOLE SIZE SHALL BE 36" FOR 48" MH, 42" FOR 54" MH, 48" FOR 60" MH, 60" FOR 72" MH, 84" FOR 96" MH MIN DISTANCE BETWEEN HOLES SHALL BE 8" FOR 48", 54", AND 60" MH, 12" FOR 72" AND 96" MH
- MANHOLE RINGS AND COVERS SHALL MEET THE STRENGTH REQUIREMENTS OF FEDERAL SPECIFICATION A-A-60005. MATING SURFACES SHALL BE FINISHED TO ASSURE NON-ROCKING FIT WITH ANY COVER POSITION.
- ALL BASE REINFORCING STEEL SHALL HAVE A MIN YIELD STRENGTH OF 60,000 PSI AND BE PLACED IN THE UPPER HALF OF THE BASE WITH 1" MIN CLEARANCE.
- FOR HEIGHTS OF 12' OR LESS, MIN SOIL BEARING VALUE SHALL EQUAL 3,300 POUNDS PER SQUARE FOOT. FOR HEIGHTS OVER 12', MIN SOIL BEARING VALUE SHALL EQUAL 3,800 POUNDS PER SQUARE FOOT.
- FOR DETAILS SHOWING GRADE RING, LADDER, STEPS, HANDHOLDS, AND TOP SLABS, SEE COS STD 606.
- SEE WSDOT STANDARD SPECIFICATIONS SEC 7-05.3 FOR JOINT REQUIREMENTS.



PUBLICATION DATE: **3/1/2022** REVISION DATE: **4/30/2021**  
 STANDARD DETAIL NUMBER: **603** SCALE: **NOT TO SCALE**

**MANHOLE TYPE III- SANITARY**

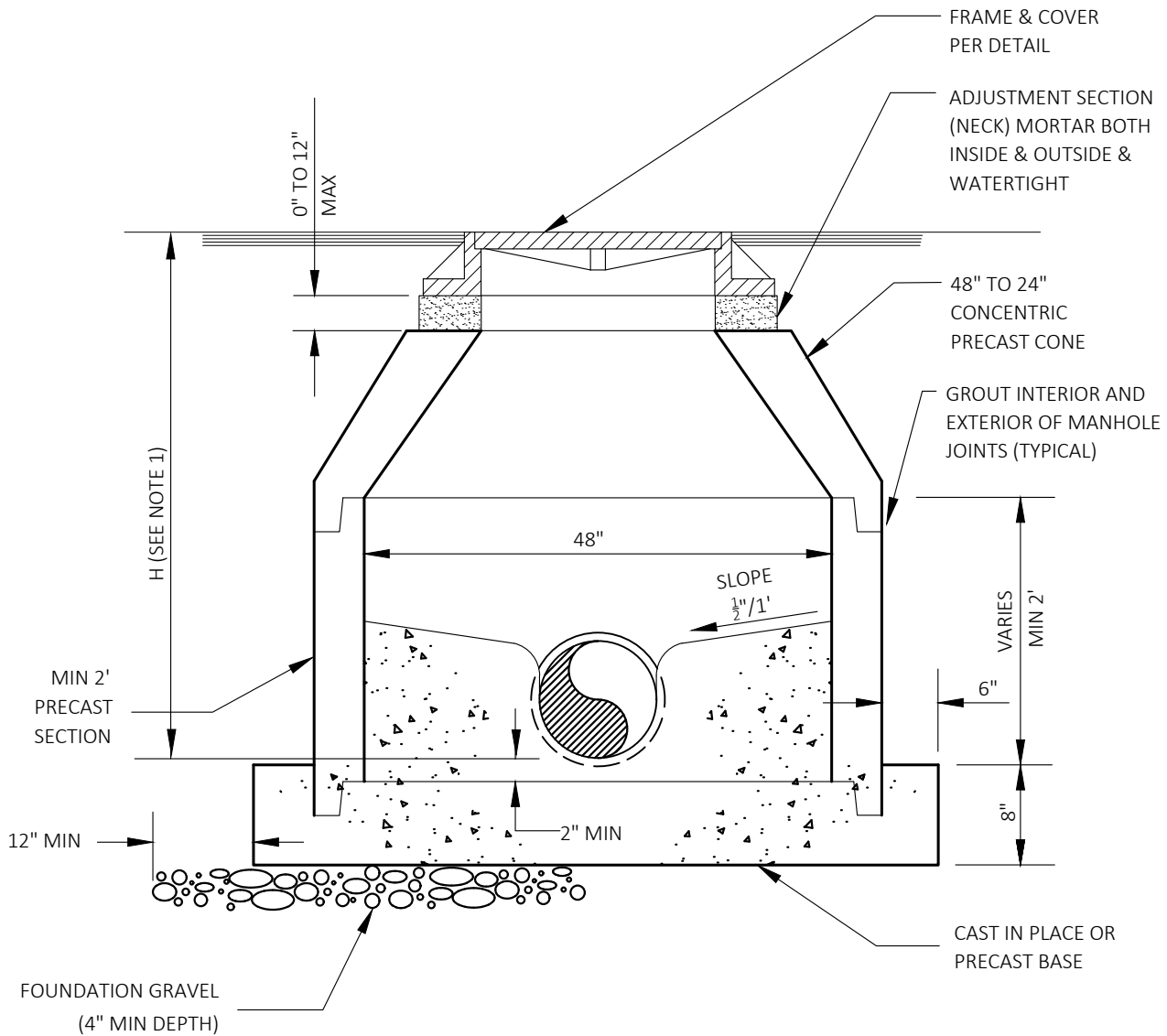

**NOTES:**

1. MAXIMUM H IS 5'. WHEN H IS LESS THAN 3'-6", USE A CONCENTRIC FLAT TOP SLAB.
2. TO BE USED ONLY WITH PRIOR AUTHORIZATION.
3. MAXIMUM PIPE SIZE 12".
4. PIPE MANHOLE COLLAR REQUIRED FOR PVC PIPE.



PUBLICATION DATE: **3/1/2022** REVISION DATE: **4/30/2021**

STANDARD DETAIL NUMBER: **604** SCALE: **NOT TO SCALE**

**MANHOLE TYPE IIIA 48 IN-SANITARY**

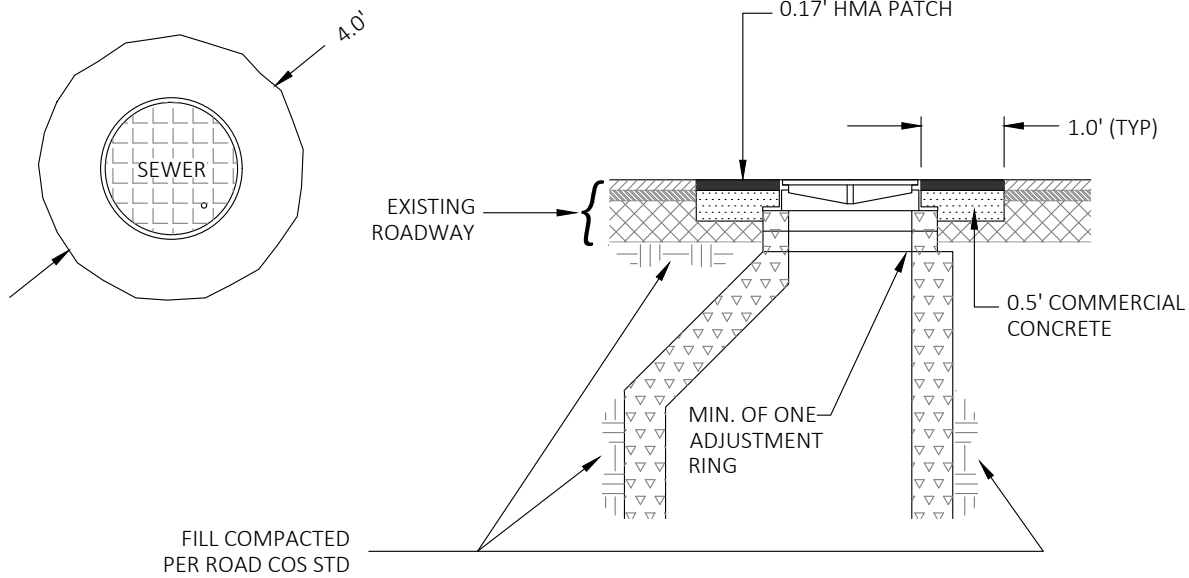

**MANHOLE IN PAVED AREA**

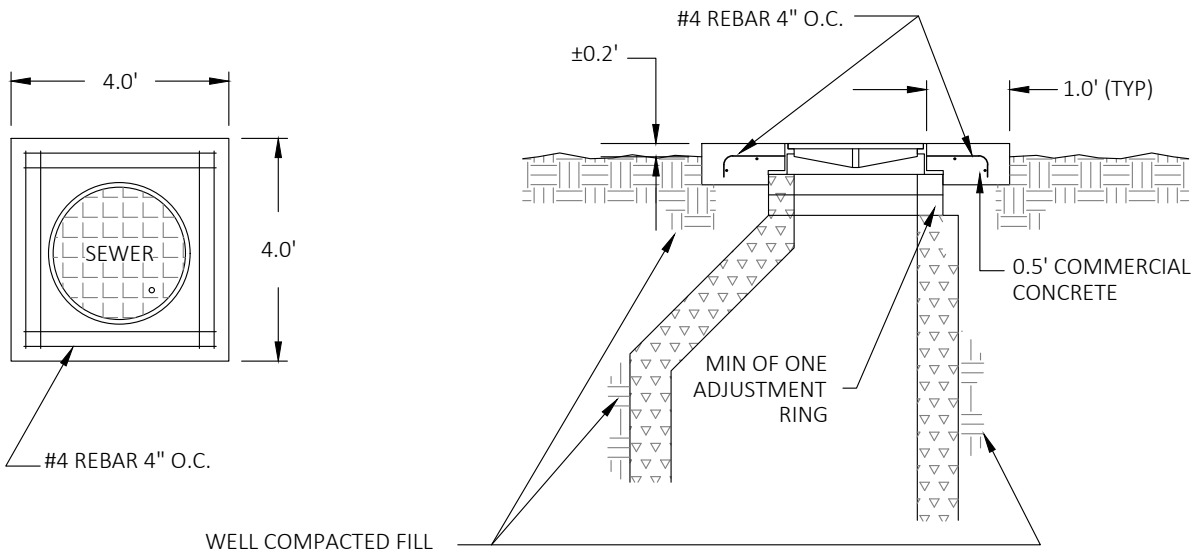

**MANHOLE OUTSIDE PAVED AREA**

**NOTES:**

1. ON MANHOLE OUTSIDE ASPHALT, ADD REINFORCING STEEL AS SHOWN ABOVE. DEFORMED BAR TO MEET ASTM A615 GRADE 60, FY=60,000 P.S.I.
2. OPENING IN LID FOR USE OF MANHOLE HOOK IS REQUIRED.
3. MANHOLE COVERS SHALL BE LOCKING TYPE.

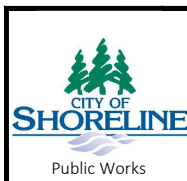

PUBLICATION DATE: <b>3/1/2022</b>	REVISION DATE: <b>4/30/2021</b>
STANDARD DETAIL NUMBER: <b>605</b>	SCALE: <b>NOT TO SCALE</b>

**MANHOLE OUTSIDE PAVING  
CONCRETE COLLAR - SANITARY**

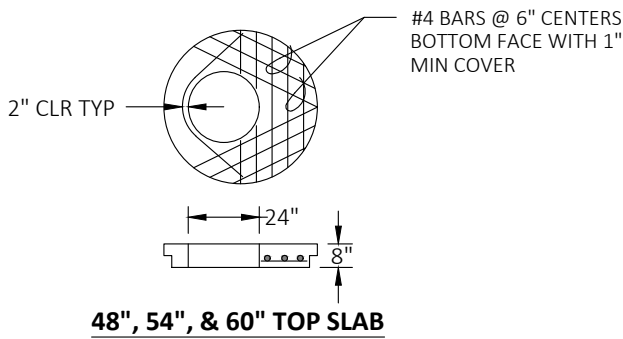

\* ALL STEPS & RUNGS 1" DIA GALV  
REBAR OR COPOLYMER PROPYLENE

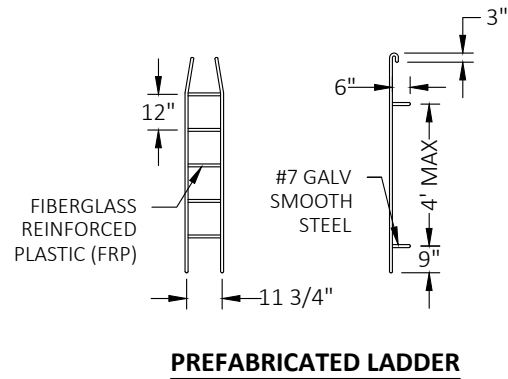
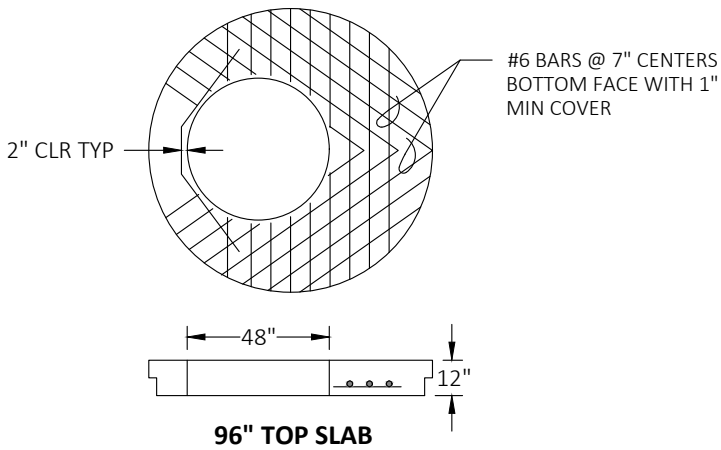
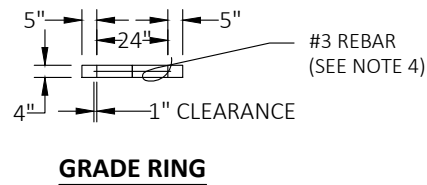
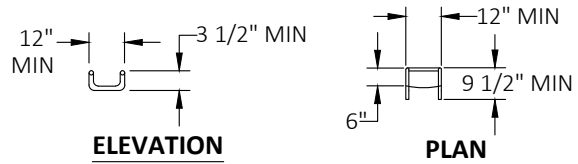
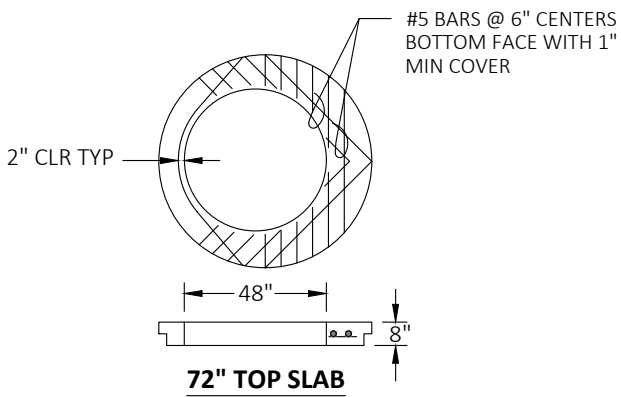
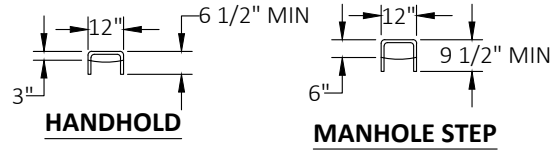

**NOTES:**

1. PROPRIETARY MANHOLE HANDHOLDS AND STEPS ARE ACCEPTABLE, PROVIDED THAT THEY CONFORM TO SEC R, ASTM C478, AASHTO M199 AND MEET ALL WISHA REQUIREMENTS.
2. MANHOLE STEP/HANDHOLD LEGS SHALL BE PARALLEL OR APPROXIMATELY RADIAL AT THE OPTION OF THE MANUFACTURER, EXCEPT THAT ALL STEPS IN ANY MANHOLE SHALL BE SIMILAR. PENETRATION OF OUTER WALL BY A LEG IS PROHIBITED.
3. HANDHOLDS AND STEPS SHALL HAVE "DROP" RUNGS OR PROTUBERANCES TO PREVENT SIDEWAYS SLIP.
4. LADDERS OR STEPS SHALL EXTEND TO WITHIN 16" OF BOTTOM OF MANHOLE.
5. HANGING LADDERS SHALL BE PERMANENTLY FASTENED AT TOP BY HANGING ON STEP OR BY BOLTING OR EMBEDDING IN CONCRETE. EACH SHALL BE EMBEDDED AT BOTTOM IN BASE.
6. ADDITIONAL SAFETY FEATURES MAY BE REQUIRED.

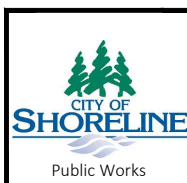

PUBLICATION DATE: **3/1/2022** REVISION DATE: **4/30/2021**

STANDARD DETAIL NUMBER: **606** SCALE: **NOT TO SCALE**

**MANHOLE LADDER & HANDHOLD  
DETAIL - SANITARY**

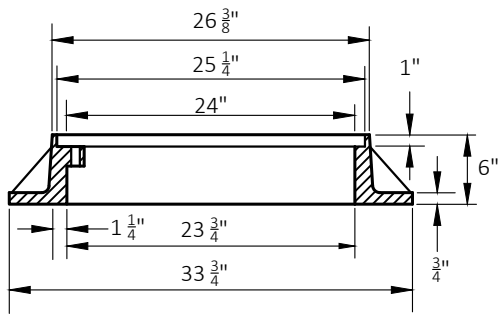
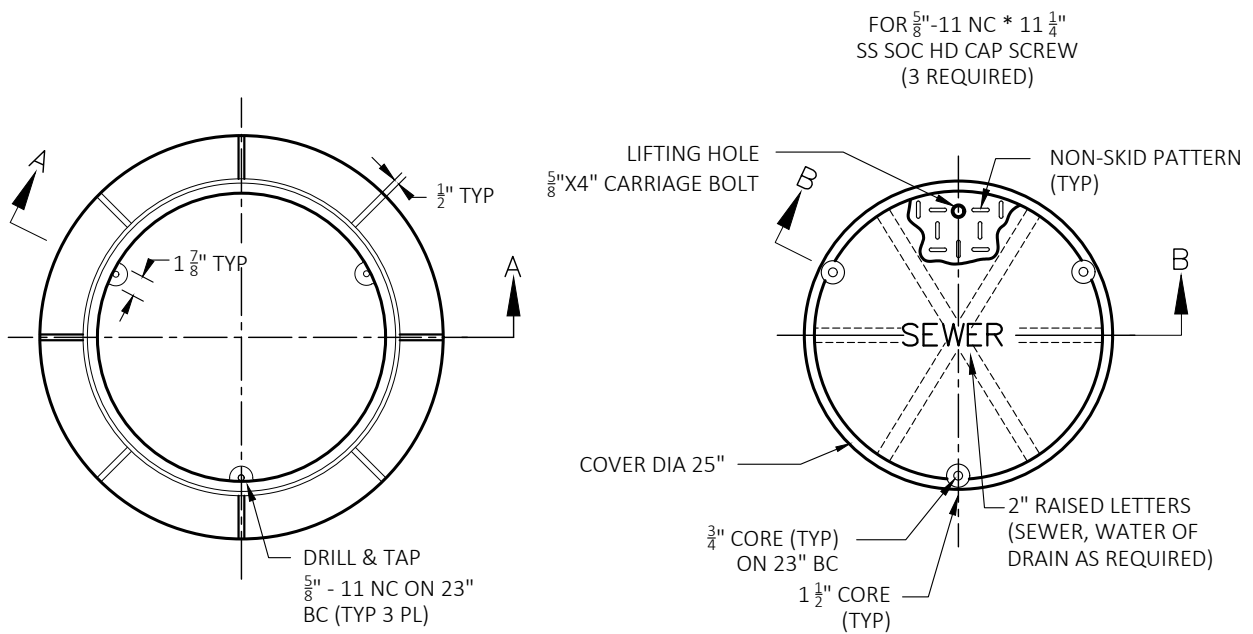

**SECTION A-A**

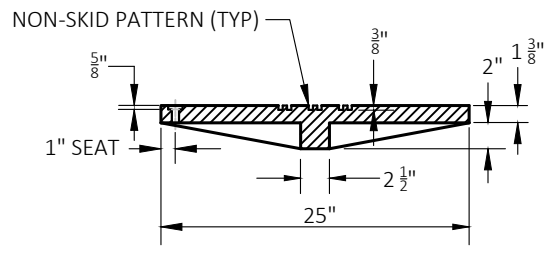

**SECTION B-B**

**NOTES:**

1. DRILL LUG HOLES FULL DEPTH.
2. BOLT COVER TO LUGS IN RING.
3. PROVIDE  $\frac{7}{8}$ "  $\phi$  LIFTING HOLE AND LIFT HOLE BOLT/NUT (5/8"x4" CARRAGE BOLT). DEFORM THREADS TO PREVENT LOSS OF NUT.
4. DUCTILE IRON COVER, CAST IRON FRAME.
5. SEE SPECIFICATION O2605 FOR ADDITIONAL REQUIREMENTS.
6. FRAME AND COVER PER APWA.
7. EJIW MODEL NUMBER 3715 ZPT OR EQUAL.



PUBLICATION DATE: <b>3/1/2022</b>	REVISION DATE: <b>10/6/2021</b>
STANDARD DETAIL NUMBER: <b>607</b>	SCALE: <b>NOT TO SCALE</b>

**MANHOLE FRAME & COVER  
SANITARY**

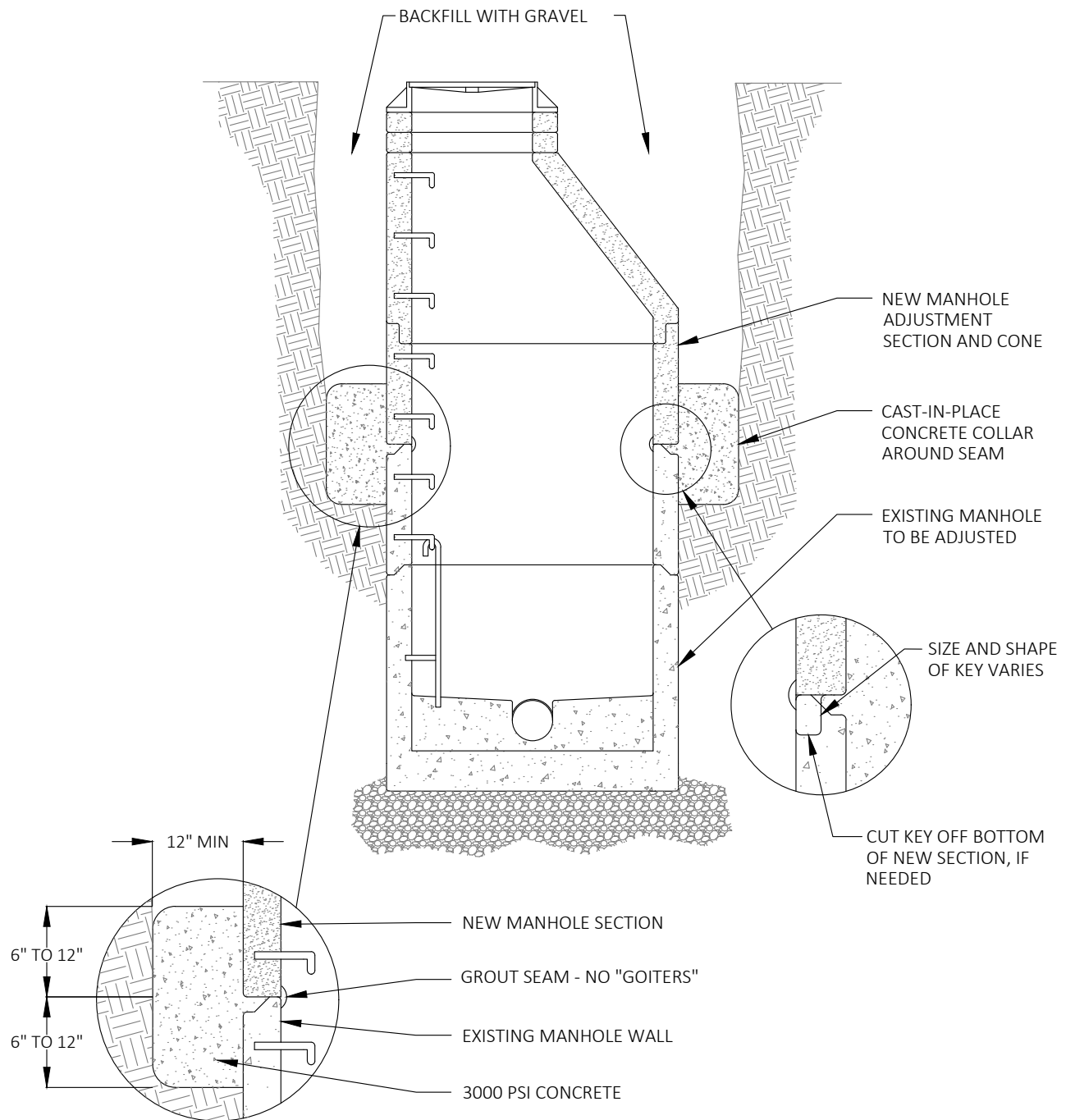

**NOTES:**

1. MANHOLE SHALL CONFORM TO THE GENERAL NOTES AND ALL APPLICABLE REQUIREMENTS OF COS STD 601.
2. WHERE DEPTH OF MANHOLE NECK EXCEEDS 24", ADJUST MANHOLE TO GRADE BY INSTALLING NEW MANHOLE BARREL SECTION AND CONE ON EXISTING MANHOLE BARREL.
3. WHERE KEY SECTIONS OF NEW AND EXISTING MANHOLES ARE NOT COMPATIBLE, CUT KEY OFF BOTTOM OF NEW SECTION AND PROVIDE A CAST-IN-PLACE CONCRETE COLLAR AROUND MANHOLE PERIMETER. CAST COLLAR WITH 3000 PSI CONCRETE.
4. UPWARD ADJUSTMENT OF EXISTING MANHOLES MUST BE DONE WITH ALL NEW PARTS, AS NECESSARY, TO ENSURE ONLY ONE INCOMPATIBLE SEAM.
5. GROUT ALL JOINTS INSIDE, OUTSIDE AND IN BETWEEN TO ACHIEVE WATERTIGHT CONSTRUCTION. FINISH SMOOTH THE INSIDE OF STRUCTURE. USE NON-SHRINK GROUT ONLY.

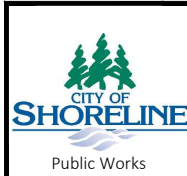

PUBLICATION DATE: <b>3/1/2022</b>	REVISION DATE: <b>4/30/2021</b>
STANDARD DETAIL NUMBER: <b>608</b>	SCALE: <b>NOT TO SCALE</b>

**MANHOLE ADJUST DETAIL-  
SANITARY**



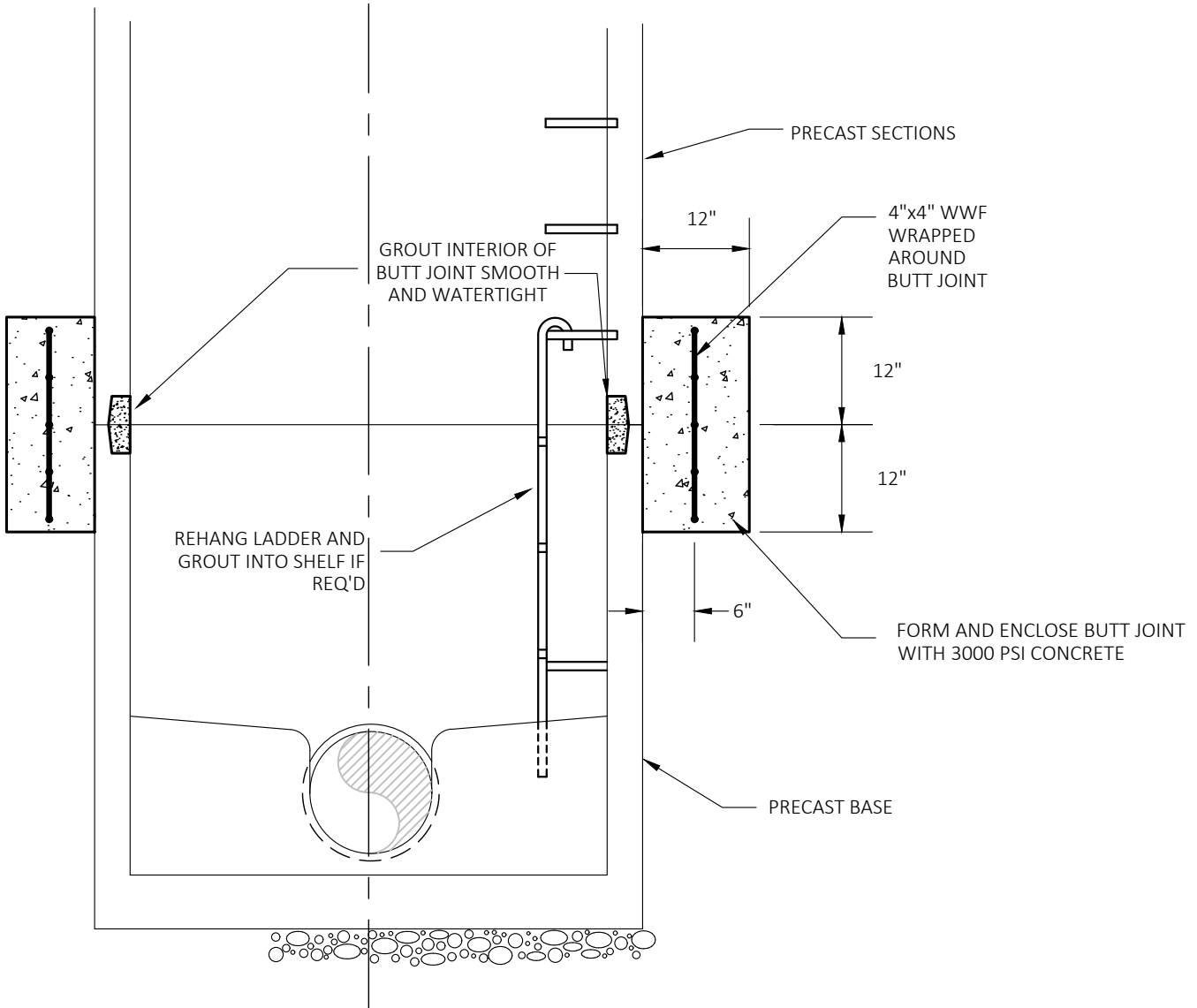

**NOTE:**

1. REQUIRES SPECIAL PERMISSION AND INSPECTION BY RWD.
2. NO WALL PENETRATIONS ALLOWED IN THE BUTT JOINT AREA.
3. PRECAST SECTION BUTT JOINT AREA MUST BE CLEAN AND UNBROKEN.



PUBLICATION DATE: **3/1/2022**

REVISION DATE: **4/30/2021**

STANDARD DETAIL NUMBER: **608A**

SCALE: **NOT TO SCALE**

**MANHOLE BUTT JOINT**

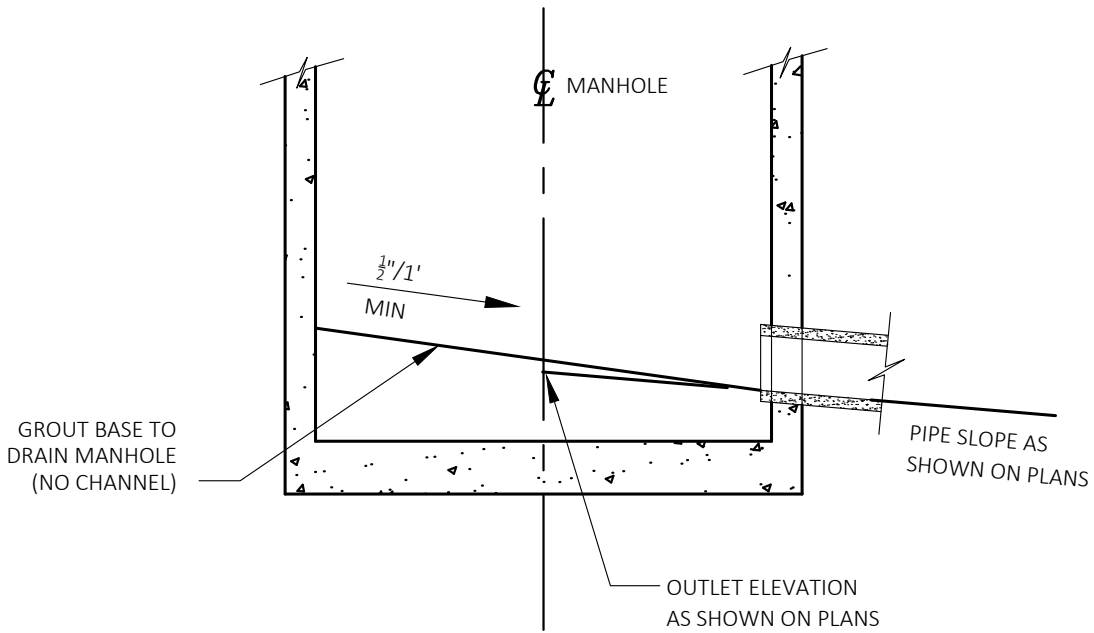

**TERMINAL MANHOLE**

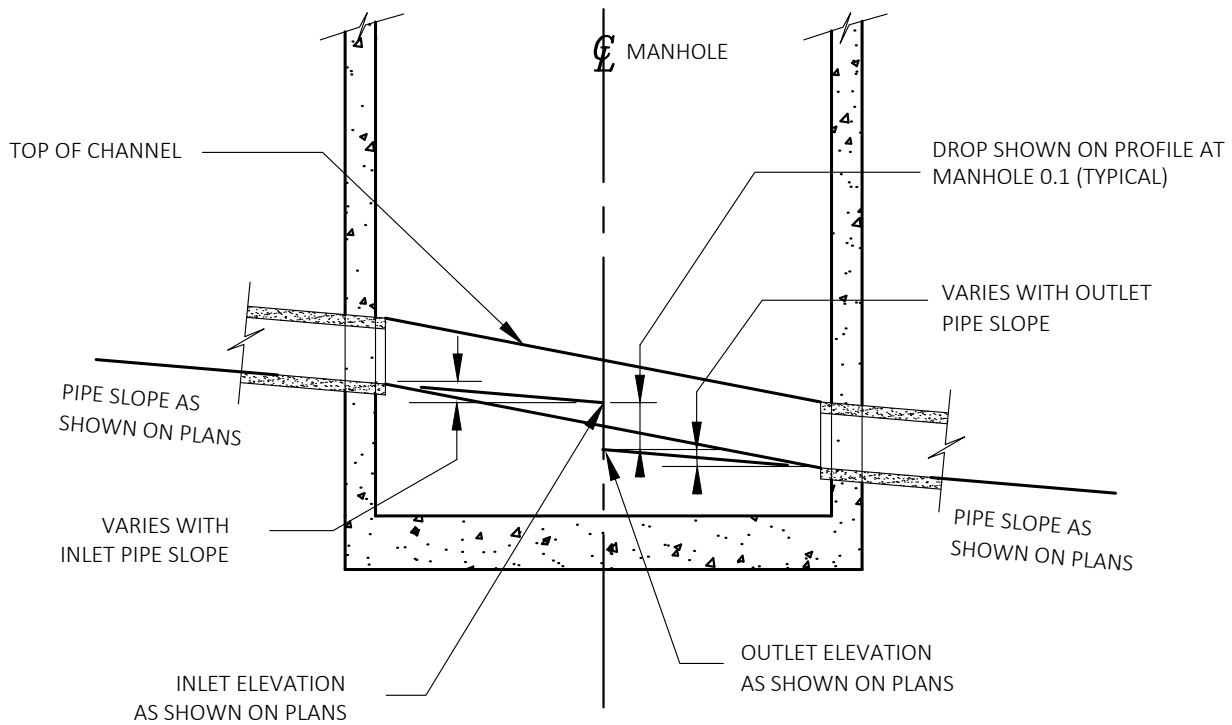

**MAIN-LINE MANHOLE**

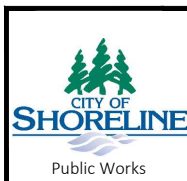

PUBLICATION DATE: **3/1/2022**

REVISION DATE: **4/30/2021**

STANDARD DETAIL NUMBER: **609**

SCALE: **NOT TO SCALE**

**MANHOLE CHANNELING DETAIL-  
SANITARY**

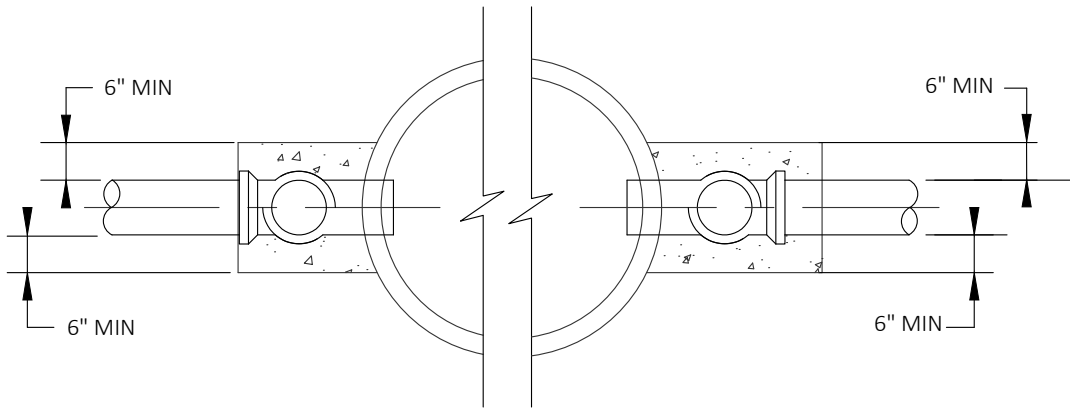

**PLAN**

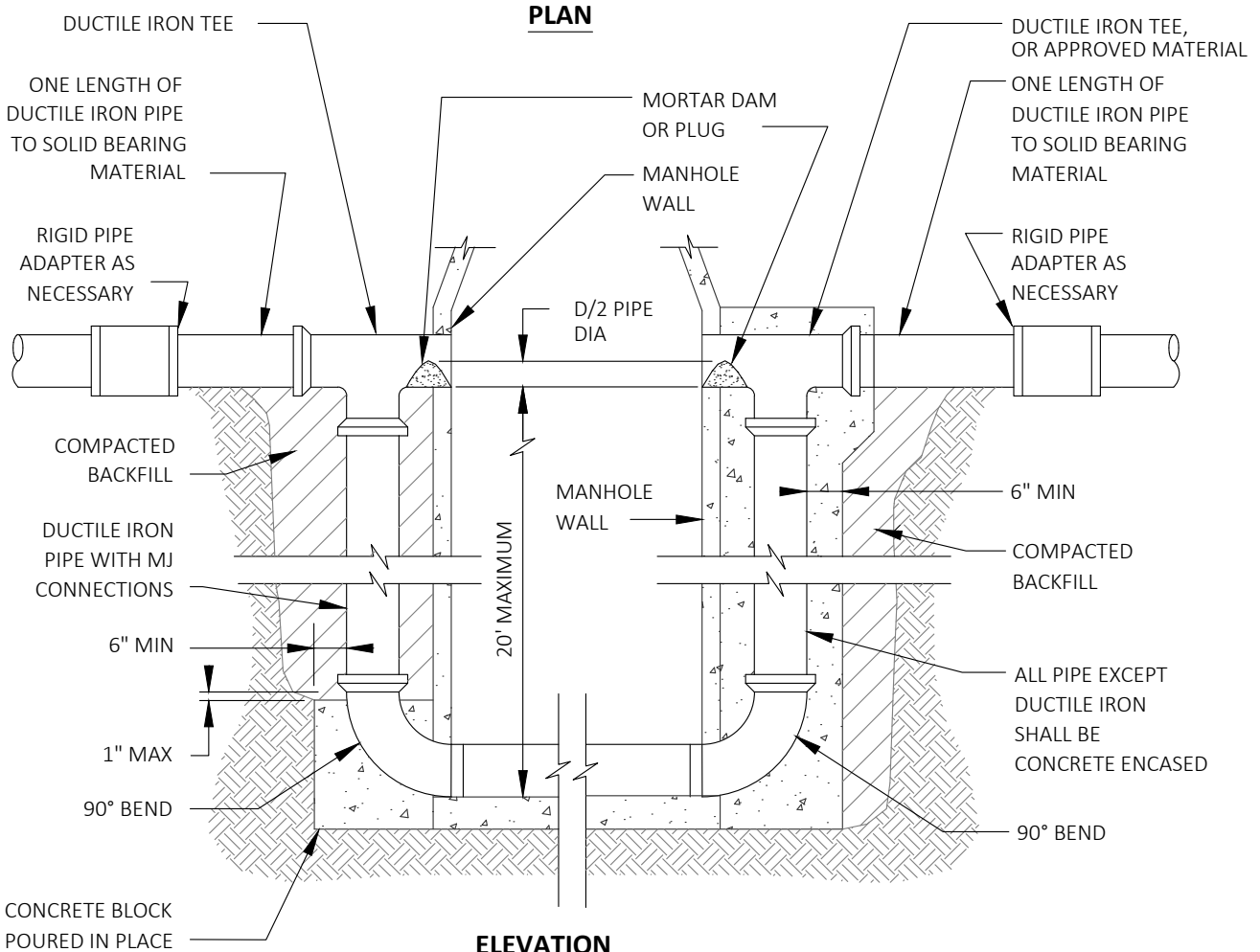

**ELEVATION**

**DUCTILE IRON**  
ALTERNATIVE

**CONCRETE ENCASED**  
ALTERNATIVE



PUBLICATION DATE: **3/1/2022** REVISION DATE: **10/6/2021**  
STANDARD DETAIL NUMBER: **610** SCALE: **NOT TO SCALE**

**MANHOLE OUTSIDE DROP CONNECTION- SANITARY**

ALIGN PIPE TOWARDS FLOWLINE

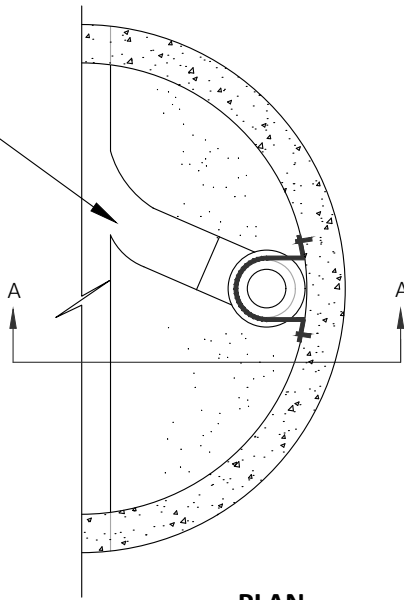

**PLAN**

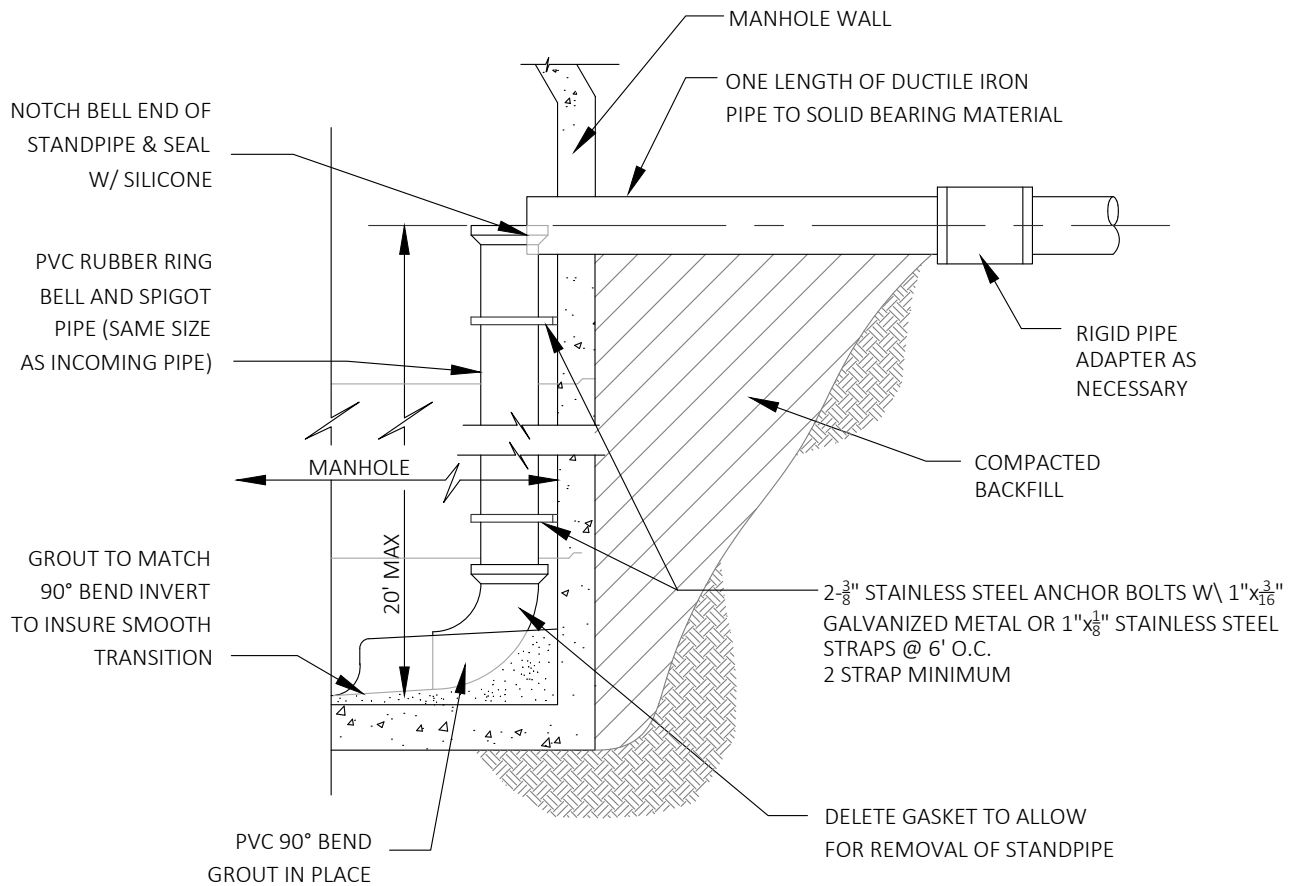

**ELEVATION**

SECTION A-A

NOTE: THIS ASSEMBLY TO BE USED ONLY WITH SPECIFIC AUTHORIZATION

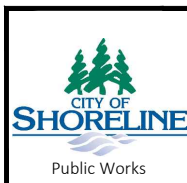

PUBLICATION DATE: **3/1/2022**

REVISION DATE: **10/6/2021**

STANDARD DETAIL NUMBER: **611**

SCALE: **NOT TO SCALE**

**MANHOLE INSIDE DROP CONNECTION - SANITARY**

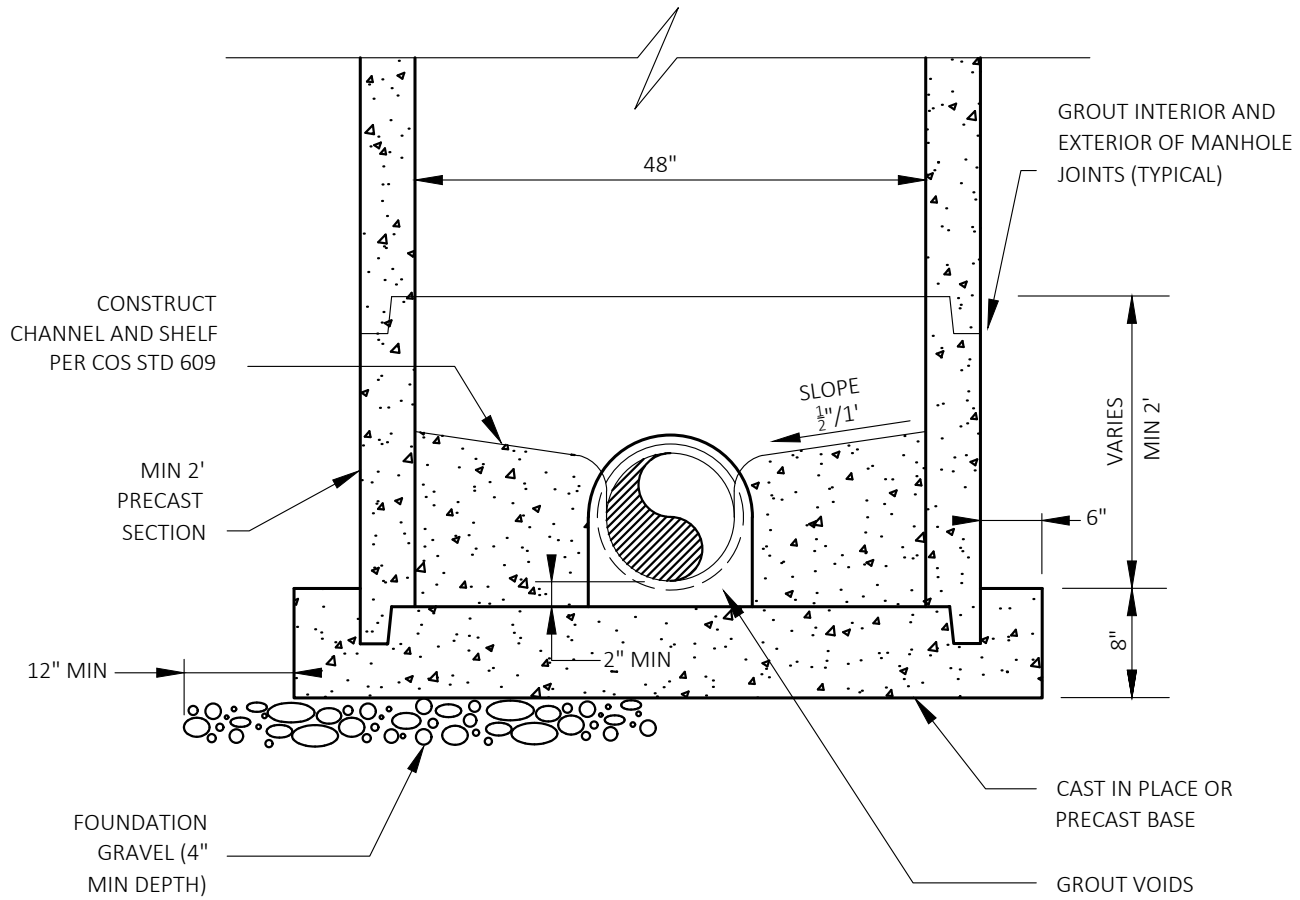

NOTES:

1. SEWER MAIN TO REMAIN IN SERVICE THROUGHOUT CONSTRUCTION PERIOD.
2. DO NOT CUT INTO SEWER MAIN UNTIL REMAINDER OF EXTENSION IS READY FOR SERVICE AND AUTHORIZED BY CITY.

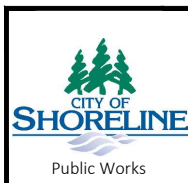

PUBLICATION DATE: **3/1/2022** REVISION DATE: **4/30/2021**

STANDARD DETAIL NUMBER: **612** SCALE: **NOT TO SCALE**

**SADDLE TYPE 48 IN DROP IN  
MANHOLE - SANITARY**

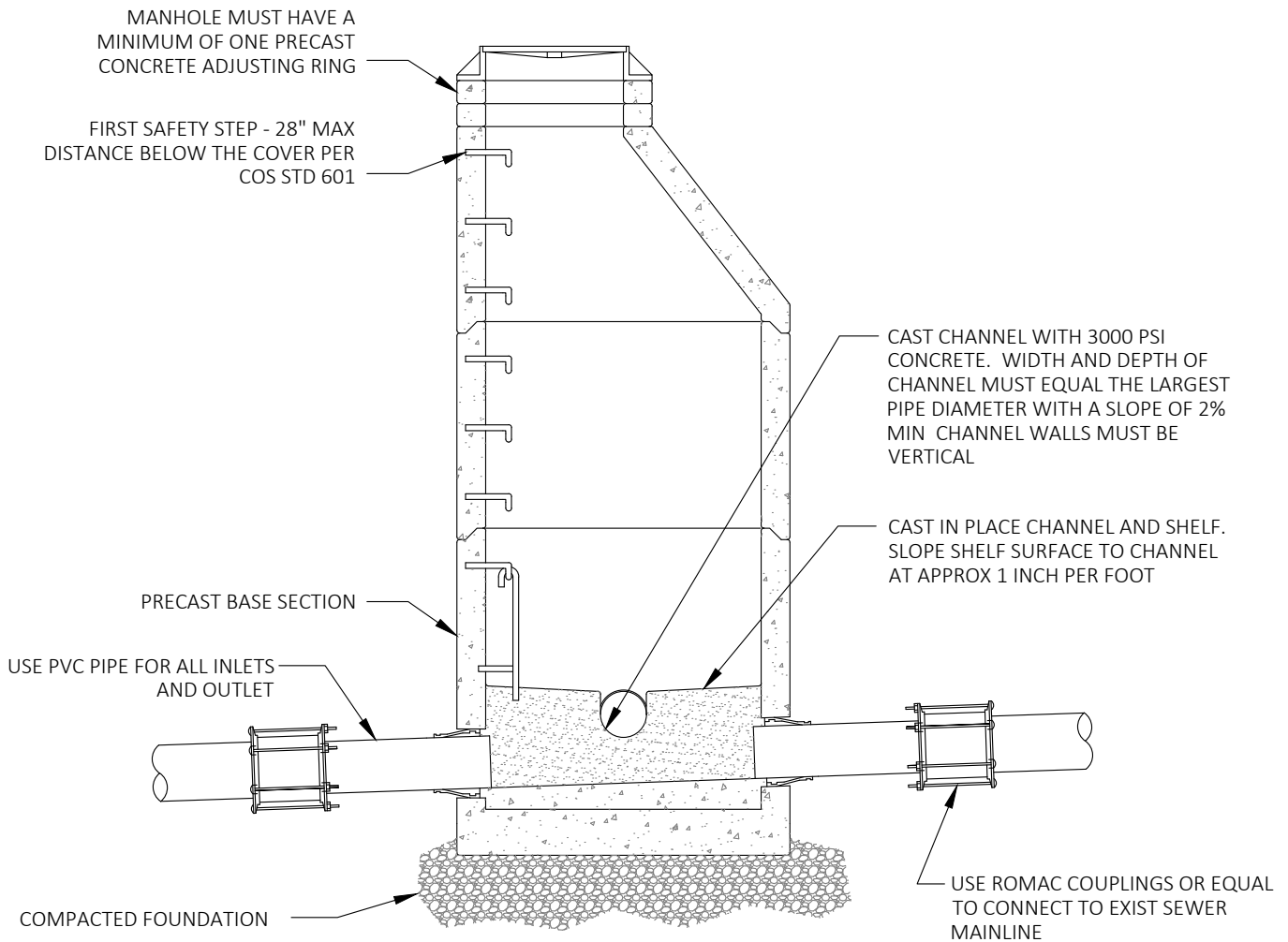

**NOTES:**

1. MANHOLE SHALL CONFORM TO THE GENERAL NOTES AND ALL APPLICABLE REQUIREMENTS OF COS STD 601.
2. THE ENTRY ANGLE OF THE NEW SEWER CONNECTION, RELATIVE TO THE EXISTING SEWER MAIN INLET, SHALL BE 90° OR LESS.
3. IF NEW SEWER CONNECTION IS A MAINLINE, THE INVERT OF THE NEW PIPE SHALL BE SET AT THE SPRINGLINE OF THE EXISTING MAINLINE.
4. IF NEW SEWER CONNECTION IS A SIDE SEWER, THE INVERT OF THE NEW PIPE SHALL BE SET AT OR ABOVE THE CROWN OF THE EXISTING MAINLINE. NEW CONNECTION NOT TO EXCEED 18" ABOVE THE MAINLINE INVERT.
5. PVC PIPE CONNECTION TO MANHOLE: KOR-N-SEAL OR EQUAL FOR CORE-DRILLED SECTIONS, OR SAND COLLAR FOR SECTIONS WITH KNOCKOUTS.
6. CONNECT NEW PVC PIPE TO EXISTING SEWER MAINLINE WITH ROMAC COUPLING OR EQUAL.
7. GROUT ALL JOINTS INSIDE, OUTSIDE AND IN BETWEEN TO ACHIEVE WATERTIGHT CONSTRUCTION. FINISH SMOOTH THE INSIDE OF STRUCTURE. USE NON-SHRINK GROUT ONLY.



PUBLICATION DATE: **3/1/2022**

REVISION DATE: **4/30/2021**

STANDARD DETAIL NUMBER: **613**

SCALE: **NOT TO SCALE**

**MANHOLE CUT IN MAIN SECTION -  
SANITARY**

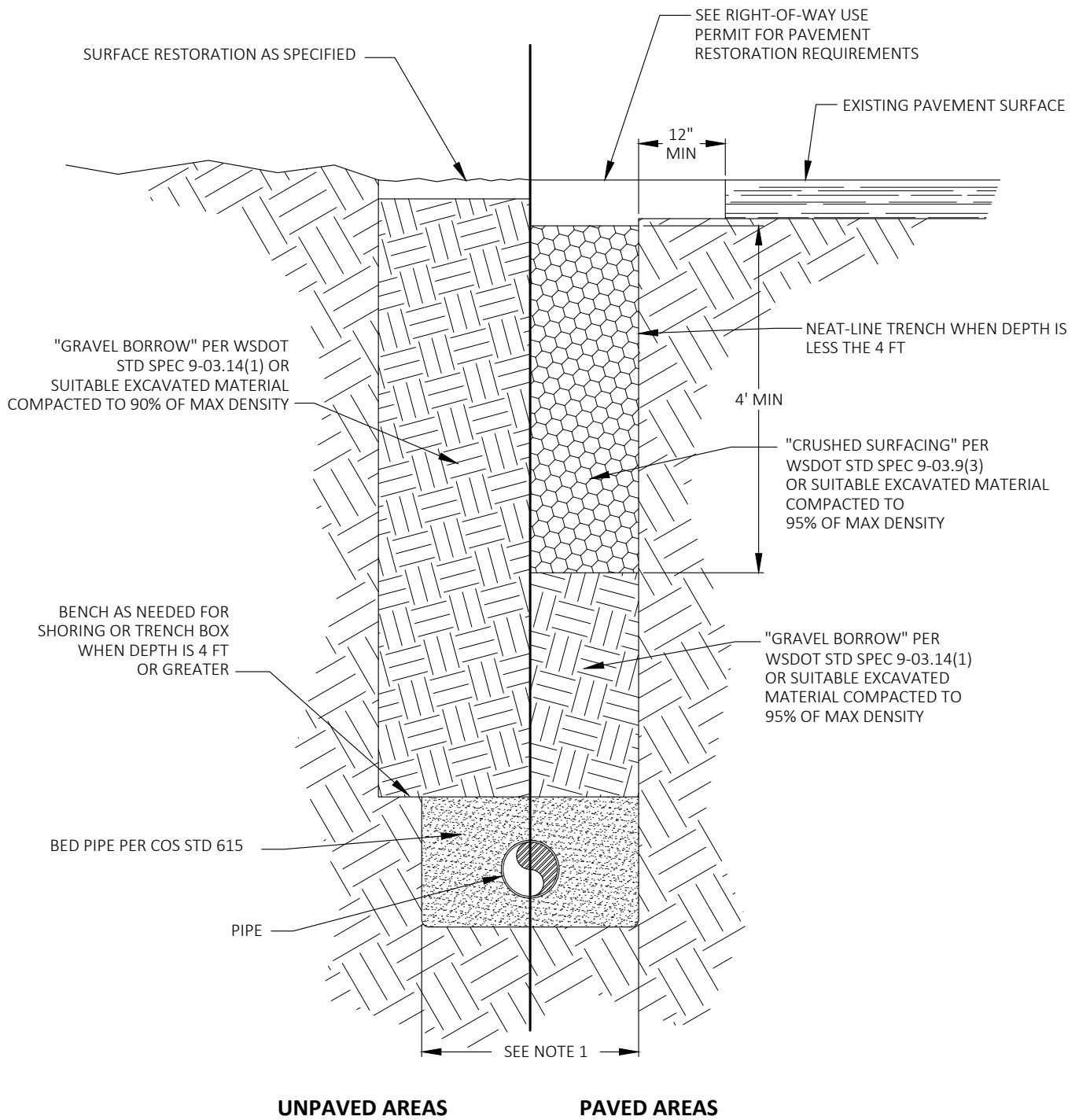

**NOTES:**

1. MAXIMUM WIDTH OF TRENCH AT TOP OF PIPE:
  - 30" FOR PIPE UP TO AND INCLUDING 12" NOMINAL DIAMETER.
  - O.D. PLUS 16" FOR PIPE LARGER THAN 12" NOMINAL DIAMETER.
2. EXCAVATIONS OVER 4" DEEP SHALL COMPLY WITH THE SAFETY STANDARD DESCRIBED IN CHAPTER 296-155 - PART N OF THE WAC.
3. SEE "BEDDING, BACKFILL AND COMPACTION" IN CHAPTER S5 OF THE ENGINEERING STANDARDS FOR ADDITIONAL CONSTRUCTION REQUIREMENTS.
4. FOE PIPE BEDDING SEE COS STD 615.

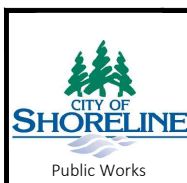

PUBLICATION DATE: <b>3/1/2022</b>	REVISION DATE: <b>4/30/2021</b>
STANDARD DETAIL NUMBER: <b>614</b>	SCALE: <b>NOT TO SCALE</b>

**TYPICAL TRENCH DETAIL - SANITARY**

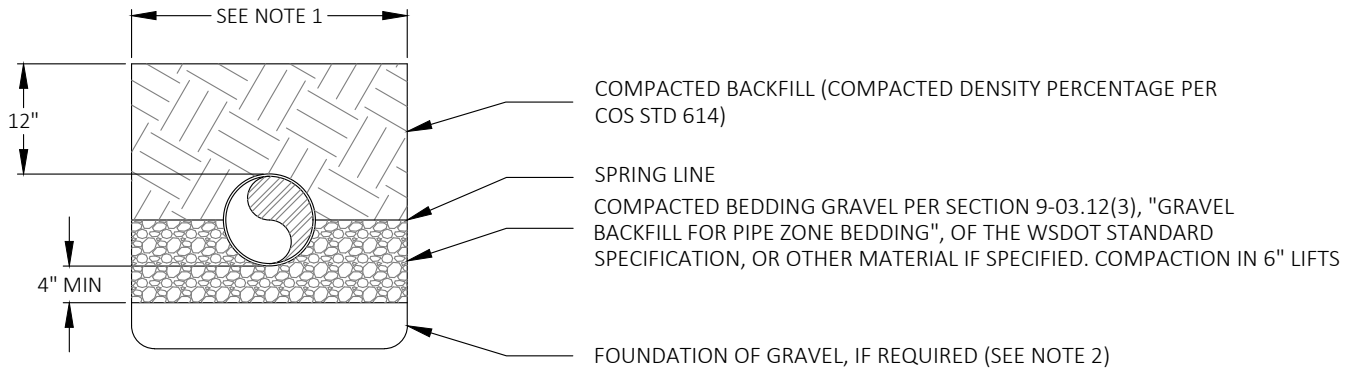

### RIGID PIPE BEDDING

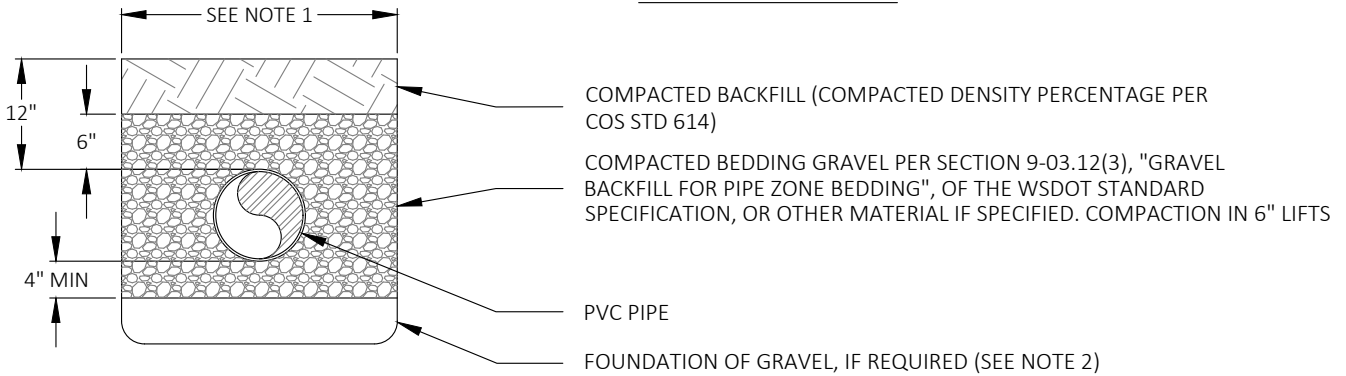

### FLEXIBLE PIPE BEDDING

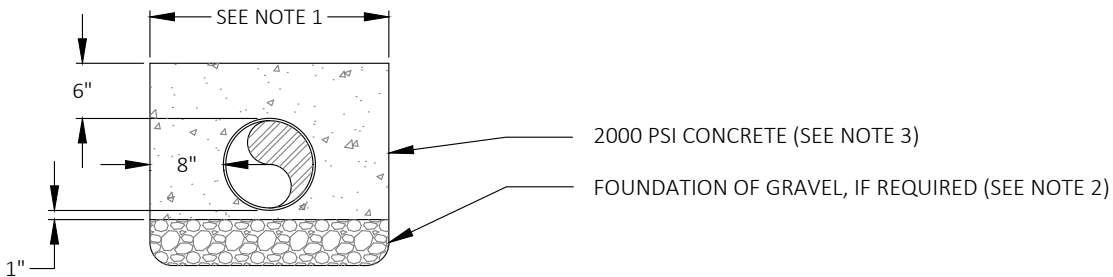

### CONCRETE ENCASEMENT

#### NOTES

1. FOR PIPES 15-INCHES AND UNDER, TRENCH WIDTH=I.D. + 30-INCHES. FOR PIPES 18-INCHES AND OVER, TRENCH WIDTH=(1.5 x I.D.)+18-INCHES. PER SECTION 2-09.4, "MEASUREMENT", OF THE WSDOT STANDARD SPECIFICATIONS.
2. EXCAVATE UNSTABLE MATERIAL DOWN TO FIRM SOIL AND REPLACE WITH FOUNDATION GRAVEL PER SECTION 9-03.9(3), "BALLAST", OF THE WSDOT STANDARD SPECIFICATIONS.
3. THE CONTRACTOR SHALL BE RESPONSIBLE FOR ANCHORING PIPE TO PREVENT FLOTATION DURING CONCRETE PLACEMENT.
4. COMPACTED CRUSHED SURFACING PER SECTION 9-03.9(3), "CRUSHED SURFACING", OF THE WSDOT STANDARD SPECIFICATIONS CAN ALSO BE USED AS BEDDING GRAVEL.



PUBLICATION DATE: **3/1/2022** REVISION DATE: **4/30/2021**

STANDARD DETAIL NUMBER: **615** SCALE: **NOT TO SCALE**

**PIPE ZONE BEDDING DETAIL -  
SANITARY**



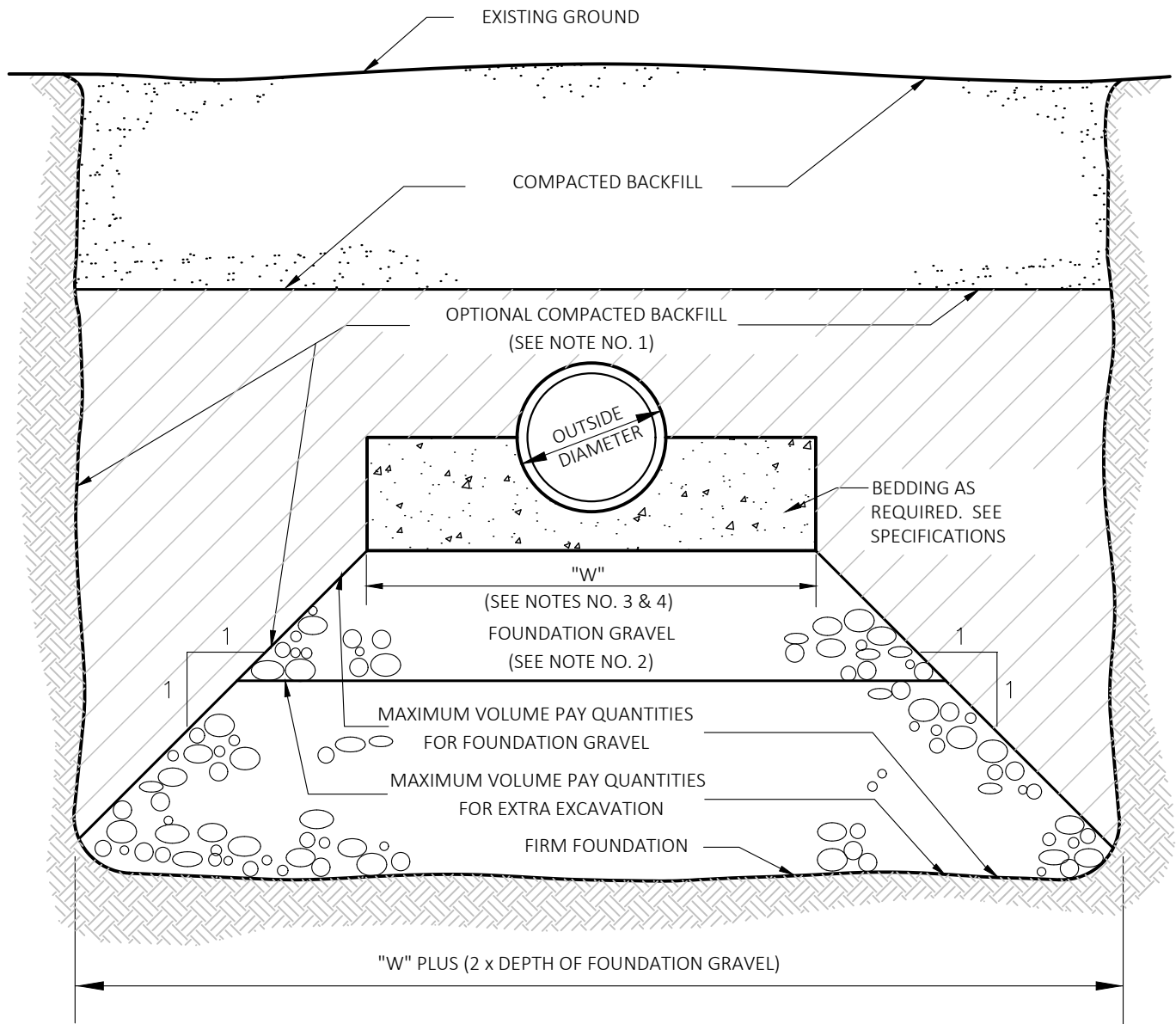

**NOTE:**

1. FOUNDATION GRAVEL OR GRAVEL BEDDING MAY BE SUBSTITUTED AT CONTRACTORS OPTION WITH NO ADDITIONAL COST TO THE OWNER.
2. REMOVE UNSUITABLE MATERIAL TO FIRM FOUNDATION AND REPLACE WITH FOUNDATION GRAVEL WHERE REQUIRED.
3. "W"=40" FOR RIGID PIPE 15" OR LESS IN DIAMETER, "W"=1.5 INTERNAL DIAMETERS PLUS 18" FOR RIGID PIPE 15" OR LARGER IN DIAMETER.
4. "W"=6 PIPE DIAMETERS FOR FLEXIBLE PIPE.
5. TICKETS NOT REQUIRED, QUANTITIES TO BE COMPUTER TO NEAT LINES SHOWN.

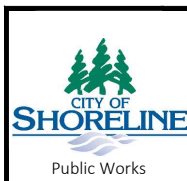

PUBLICATION DATE: <b>3/1/2022</b>	REVISION DATE: <b>4/30/2021</b>
STANDARD DETAIL NUMBER: <b>615A</b>	SCALE: <b>NOT TO SCALE</b>

## FOUNDATION GRAVEL AND BACKFILL

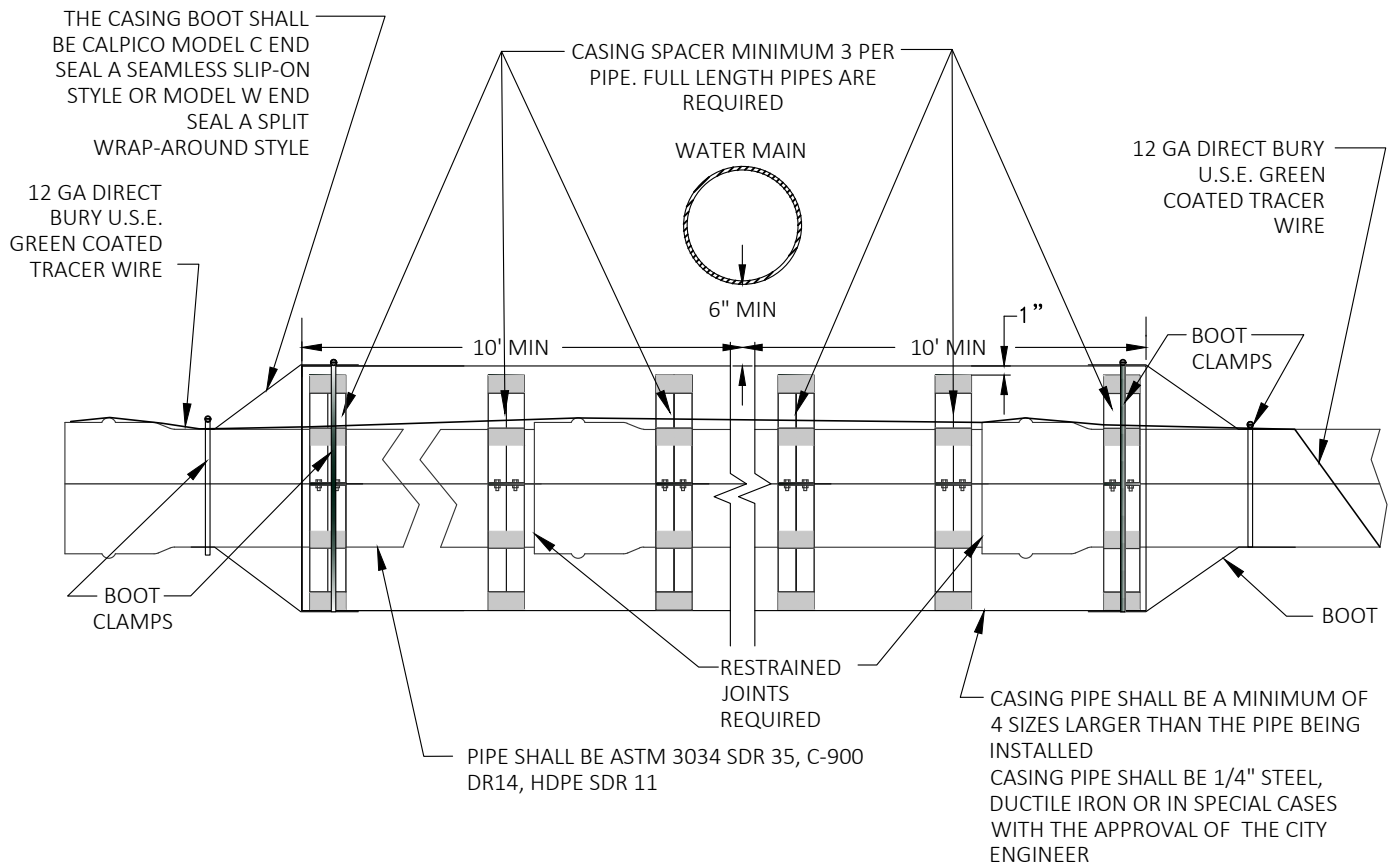

**NOTES:**

1. MANUFACTURED CASING SPACERS ARE REQUIRED AND SHALL BE UNI-FLANGE OR CALPICO INC. PRODUCTS OR AS APPROVED BY THE CITY OF SHORELINE.
2. THE PIPE LENGTHS SHALL BE 20' WITH A MINIMUM OF 3 CASING SPACERS PER PIPE.
3. THERE SHALL BE NO MORE THAN 1" OF CLEARANCE BETWEEN THE TOP OF THE SPACER TO THE TOP OF THE CASING.
4. ALL JOINTS FOR THE PIPE BEING INSTALLED SHALL BE RESTRAINED.
5. IF PLASTIC PIPE IS ALLOWED BY THE CITY THE RESTRAINTS SHALL BE APPROVED BEFORE IT CAN BE ORDERED.
6. WHEN INSTALLING PVC C-900 DR14 OR HDPE SDR 11 PIPE IN A CASING, APPROVAL FOR THE SIZE AND TYPE OF PIPE SHALL BE OBTAINED FROM THE CITY ENGINEER.
7. SINCE MOST CASING SPACERS ARE MANUFACTURED WHEN ORDERED ALL OF THE ABOVE INFORMATION SHOULD BE OBTAINED AS EARLY AS POSSIBLE SO THERE IS NO DELAY IN THE PROJECT.
8. ENCASMENT PER THIS DETAIL SHALL BE THE ONLY METHOD OF INSTALLATION FOR GRAVITY SEWER, DIRECTIONAL BORING OR BORING AND DRAGGING OF A GRAVITY SEWER MAIN IS NOT ALLOWED.



PUBLICATION DATE: <b>3/1/2022</b>	REVISION DATE: <b>4/30/2021</b>
STANDARD DETAIL NUMBER: <b>616</b>	SCALE: <b>NOT TO SCALE</b>

**SPLIT CASING DETAIL - SANITARY**

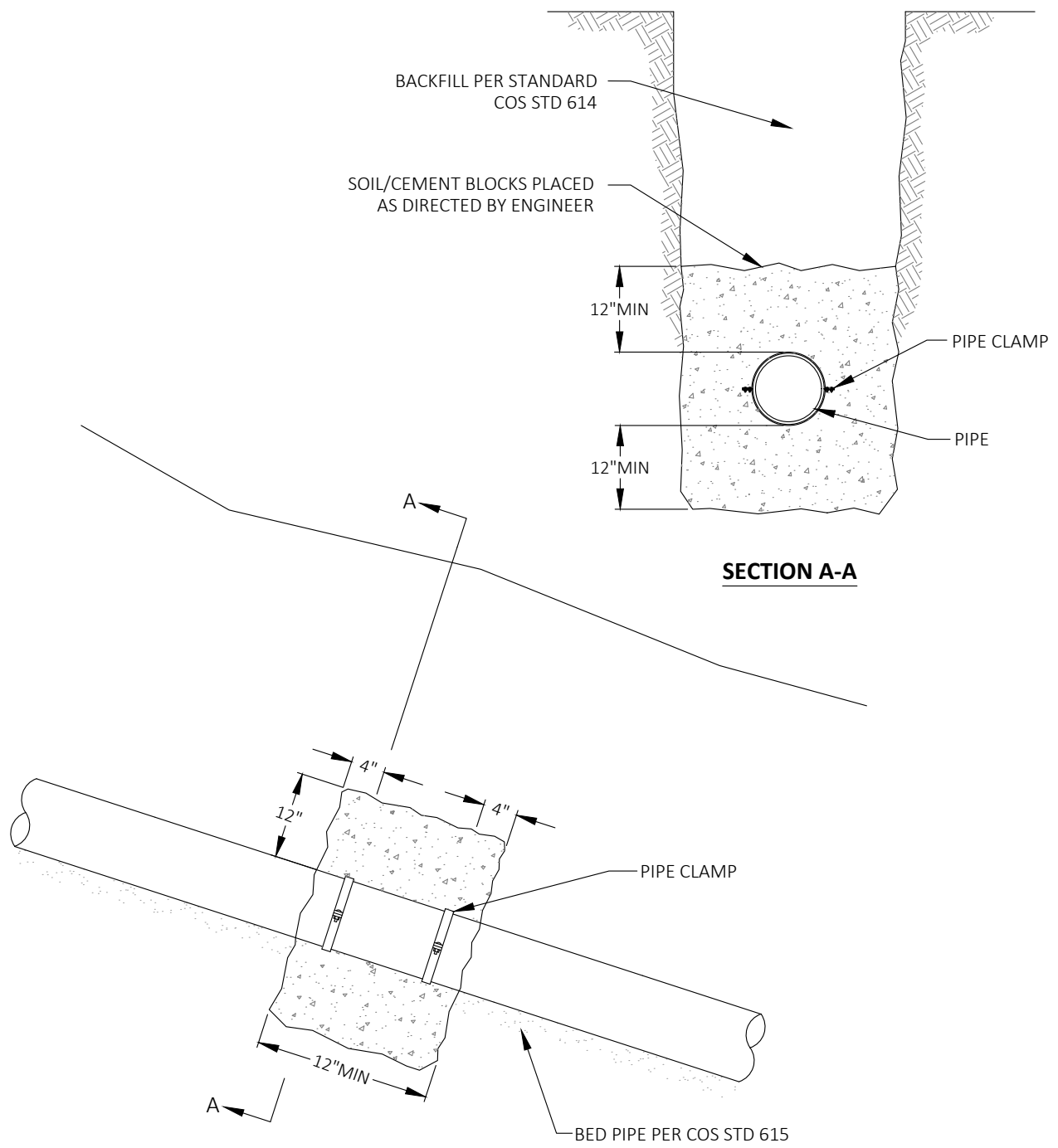

**NOTES:**

1. SOIL CEMENT BLOCKS REQUIRED ON PIPE SLOPES OF 20% OR GREATER.
2. SOIL CEMENT BLOCKS PLACED OVER AND AROUND. TAMPED INTO PLACE BEFORE BACKFILLING. USE 10% CEMENT WITH 90% NATIVE SOIL MIX. ADD ENOUGH WATER TO FORM A DRY MIX THAT WILL HOLD ITS SHAPE WHEN MOLDED INTO A BALL.
3. PLACE TWO PIPE CLAMPS, 4" FROM BLOCK ENDS TO PROVIDE ANCHORAGE TO SOIL/CEMENT MIX.
4. CONCRETE PIPE ANCHORS ALSO ACCEPTABLE WITH CITY APPROVAL.

 CITY OF SHORELINE Public Works	PUBLICATION DATE: <b>3/1/2022</b>	REVISION DATE: <b>4/30/2021</b>
	STANDARD DETAIL NUMBER: <b>617</b>	SCALE: <b>NOT TO SCALE</b>
<b>PIPE ANCHOR DETAIL - SANITARY</b>		

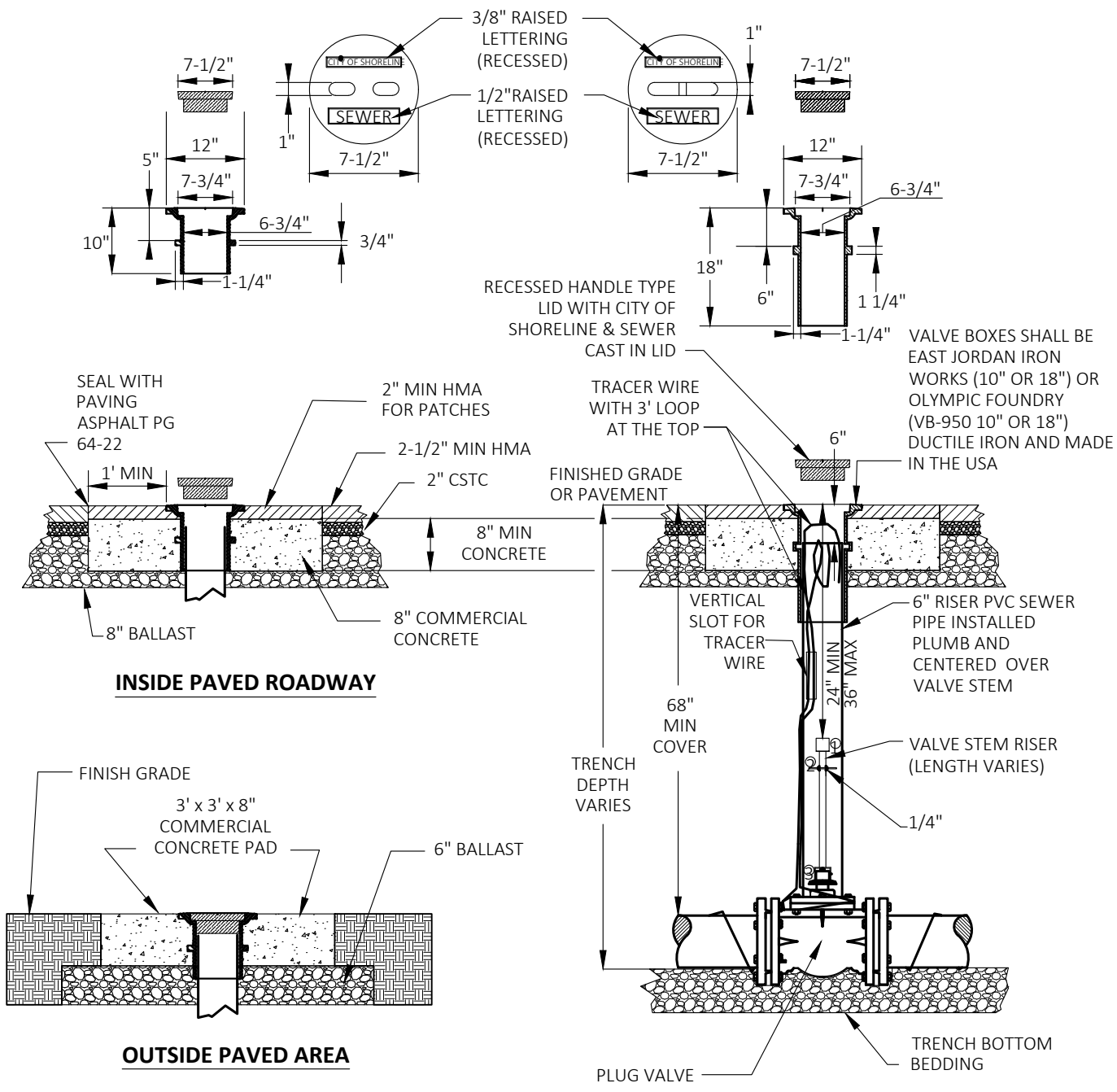

**NOTES:**

1. ALL VALVES SHALL HAVE U.S.E. 12 GAUGE GREEN COATED COPPER TRACER WIRE TIED OFF AT VALVE BODY, THE TRACER WIRE SHALL EXTENDED UP ON THE OUTSIDE PVC RISER 1' ABOVE THE HUB THEN SHOULD ENTER THE RISER PIPE AND EXTEND THREE FEET ABOVE THE TOP OF VALVE BOX.
2. ALL WELDS TO THE SHAFT SHALL BE FILLET WELD, AROUND THE ENTIRE PLATE PER #2 BELOW.

**VALVE STEM EXTENSION LEGEND**

- ① VALVE OPERATING NUT OR 1-7/8" X 1- 7/8" X 2" HIGH GRADE STEEL WELDED TO GUIDE PLATE.
- ② 3/16" THICK X 5 1/5" DIA STEEL GUIDE PLATE WELDED TO RISER SHAFT.
- ③ 2"x2"x 3/16" SQUARE STRUCTURAL STEEL TUBING TO FIT OPERATING NUT. LENGTH AS REQUIRED.

 <p><b>CITY OF SHORELINE</b> Public Works</p>	PUBLICATION DATE: <b>3/1/2022</b>	REVISION DATE: <b>4/30/2021</b>
	STANDARD DETAIL NUMBER: <b>618</b>	SCALE: <b>NOT TO SCALE</b>
<h2 style="margin: 0;">VALVE BOX DETAIL - SANITARY</h2>		

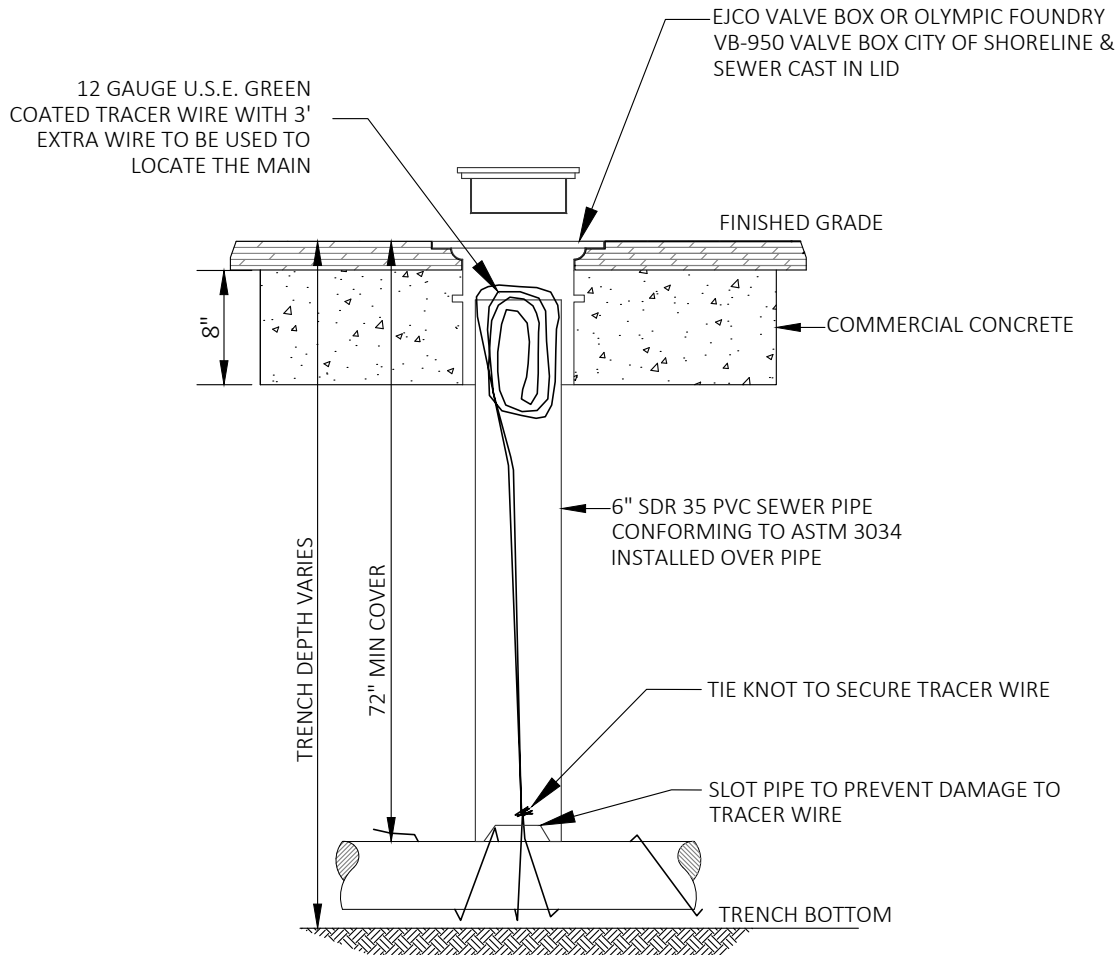

NOTE:

1. TRACER WIRE ACCESS PORT SHALL BE INSTALLED EVERY 500 FEET WHEN NO APPURTENANCES ARE CONNECTED TO IT.



PUBLICATION DATE: **3/1/2022**

REVISION DATE: **4/30/2021**

STANDARD DETAIL NUMBER: **619**

SCALE: **NOT TO SCALE**

**LOCATE WIRE DETAIL - SANITARY**

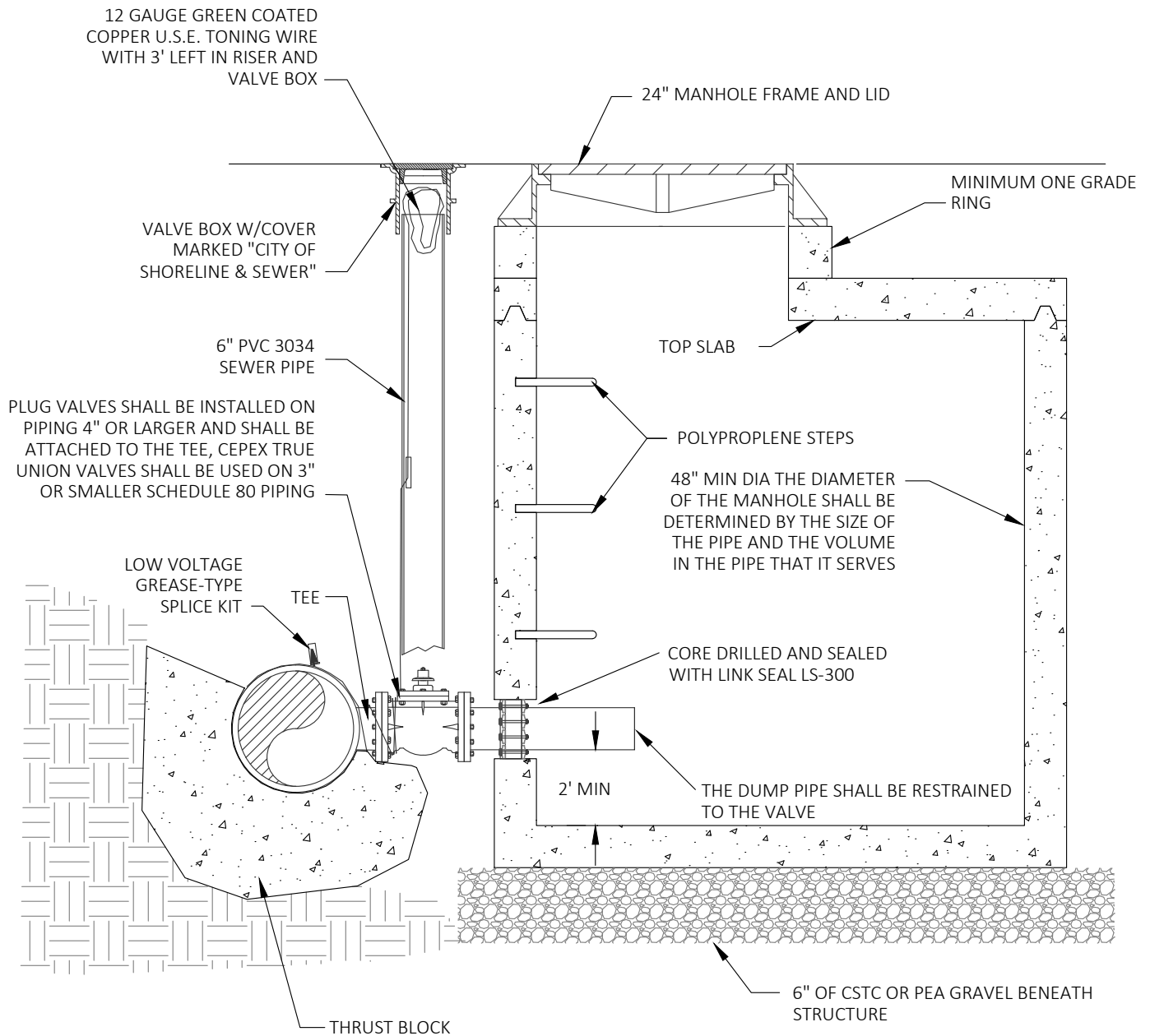

- NOTES:
1. INSTALL A CONCRETE PAD WHEN LOW POINT DRAIN MANHOLE IS INSTALLED OUTSIDE OF PAVED AREA.
  2. THE MANHOLE LID SHALL BE THE CITY OF SHORELINE "LOGO".
  3. THE SIZE OF THE LOW POINT DRAIN SHALL BE APPROVED BY THE CITY.
  4. FOR VALVE BOX REQUIREMENTS SEE COS STD 618.

 <p>CITY OF SHORELINE Public Works</p>	PUBLICATION DATE: <b>3/1/2022</b>	REVISION DATE: <b>4/30/2021</b>
	STANDARD DETAIL NUMBER: <b>620</b>	SCALE: <b>NOT TO SCALE</b>
<h2>LOW POINT DRAIN DETAIL - SANITARY</h2>		

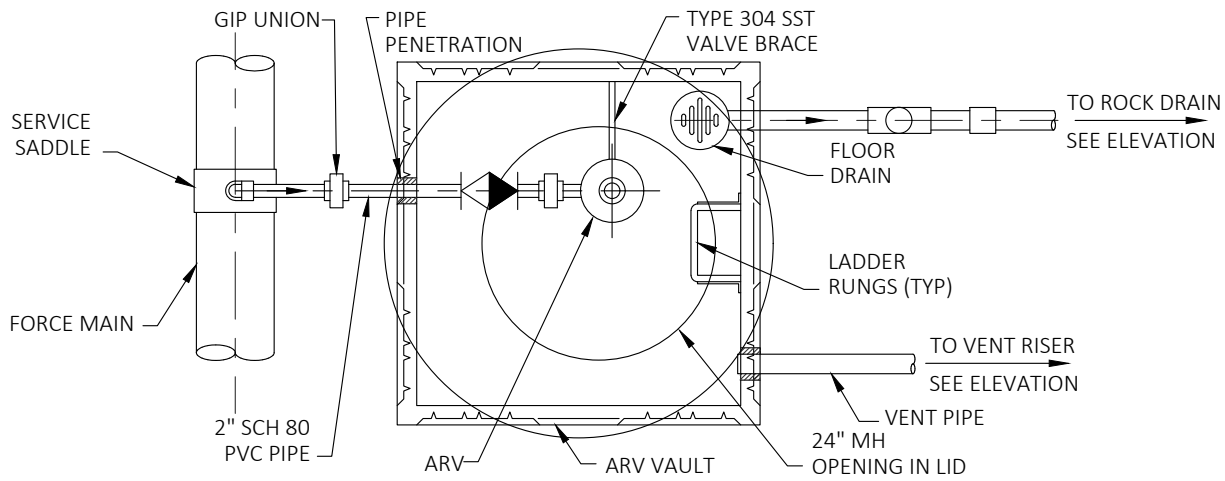

**PLAN**

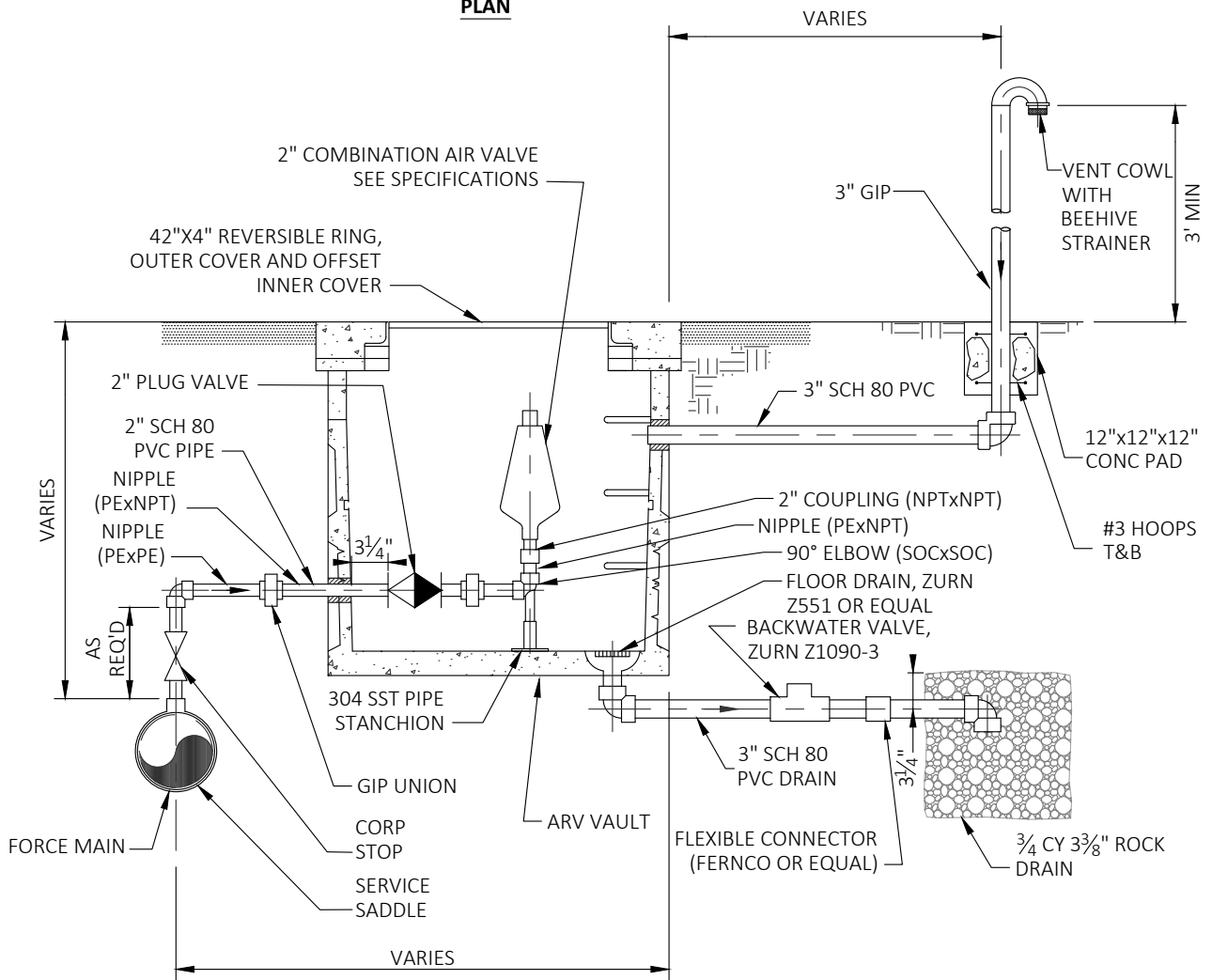

DIMENSIONS TO BE DETERMINED IN FIELD

**ELEVATION**

**NOTE:**

COMBINATION AIR VALVE ASSEMBLY SHALL INCLUDE ALL CONNECTIONS, WORK AND MATERIALS (SERVICE SADDLE TO VENT COWL) FOR A COMPLETE AND FULLY OPERATIONAL COMBINATION AIR VALVE ASSEMBLY

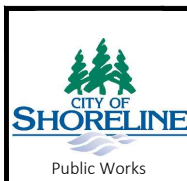

PUBLICATION DATE: **3/1/2022**

REVISION DATE: **10/6/2021**

STANDARD DETAIL NUMBER: **621**

SCALE: **NOT TO SCALE**

**AIR VALVE VAULT DETAIL -  
SANITARY**

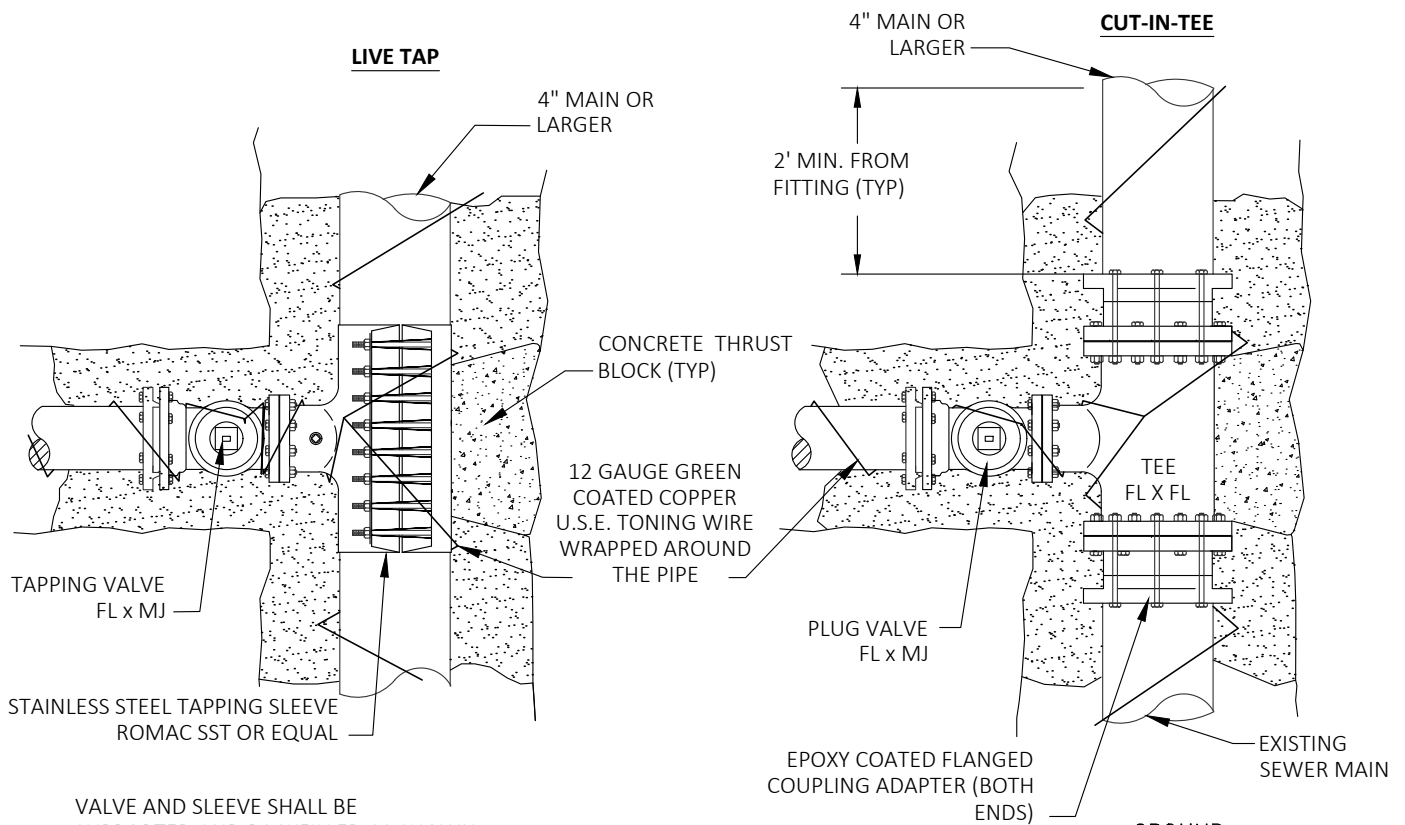

VALVE AND SLEEVE SHALL BE SUPPORTED AND BACKFILLED AS SHOWN BELOW-RIGHT

**PRECAST BASE JOINT**

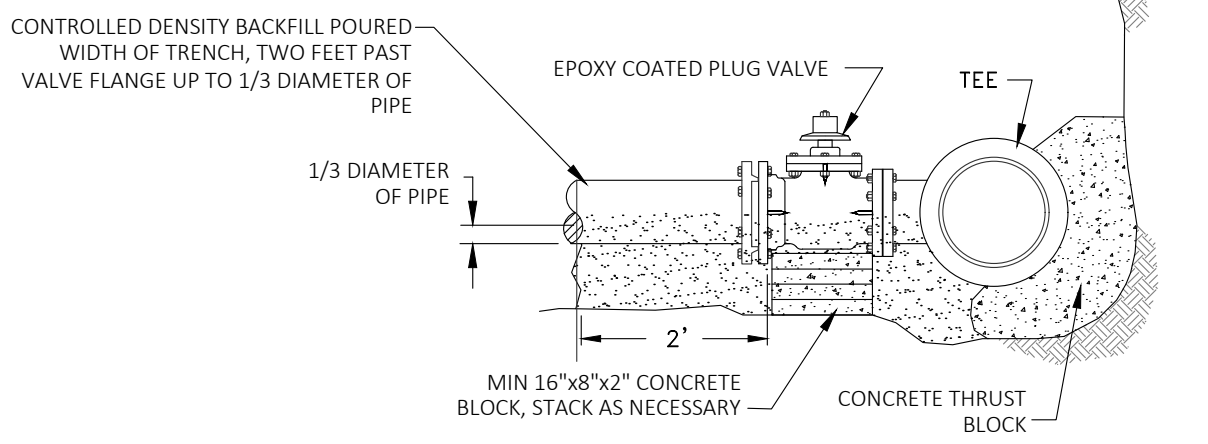

**NOTES:**

1. 11 MIL. PLASTIC OR CONSTRUCTION FABRIC SHALL BE WRAPPED AROUND PIPE AND FITTINGS BEFORE THRUST BLOCK IS POURED AND BACKFILLED.
2. CONTROLLED DENSITY FILL SHALL CONSIST OF 1750# SAND, 1750# PEA GRAVEL, 230# WATER, 141# CEMENT, 6 OZ. WATER REDUCING AGENT PER 100# CEMENT.
3. THE MINIMUM DISTANCE FOR ANY TAP OR CUT-IN SHALL BE 2' FROM A BELL END OR FITTING.
4. SUPPORT VALVE AND SLEEVE CONTINUOUSLY THROUGH INSTALLATION.
5. CONNECT TO EXISTING TRACER WIRE.
6. CUT-IN TEE SHALL BE EPOXY COATED 10 MILS THICK OR COATED WITH PROTECTO 401 OR APPROVED EQUAL.



PUBLICATION DATE: <b>3/1/2022</b>	REVISION DATE: <b>4/30/2021</b>
STANDARD DETAIL NUMBER: <b>622</b>	SCALE: <b>NOT TO SCALE</b>
<b>CONNECTION TO EXISTING PRESSURE MAIN DETAIL - SANITARY</b>	



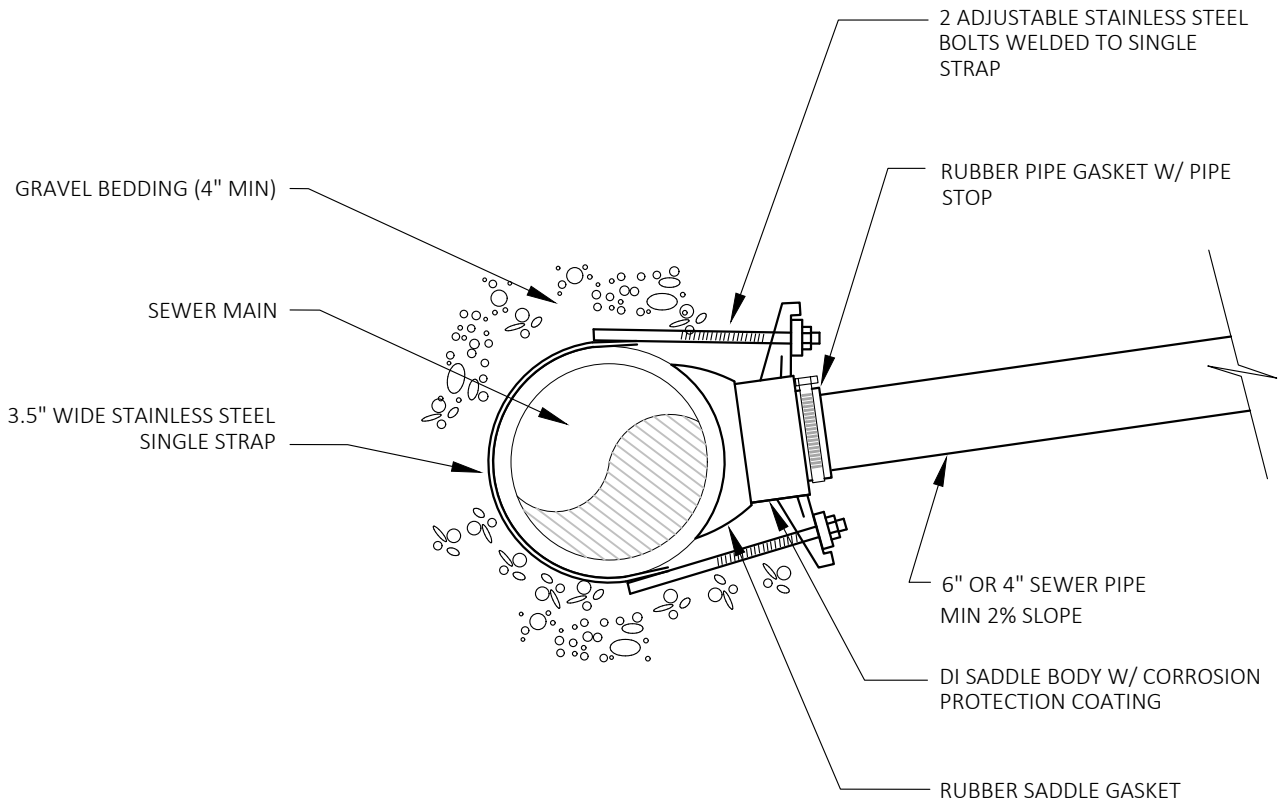

**NOTES:**

1. THIS ASSEMBLY TO BE USED ONLY WITH SPECIFIC AUTHORIZATION.
2. ROMAC STYLE CB SEWER SADDLE OR EQUAL.
3. BRANCH SEWER MUST BE MIN 2" SMALLER THAN SEWER MAIN.
4. SEE COS STD 645A FOR ADDITIONAL SIDE SEWER REQUIREMENTS.
5. FOR STEEL, CAST IRON, ASBESTOS CEMENT, PVC AND CONCRETE PIPE.

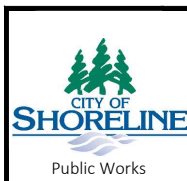

PUBLICATION DATE: **3/1/2022**

REVISION DATE: **4/30/2021**

STANDARD DETAIL NUMBER: **622A**

SCALE: **NOT TO SCALE**

**SEWER SADDLE CONNECTION**

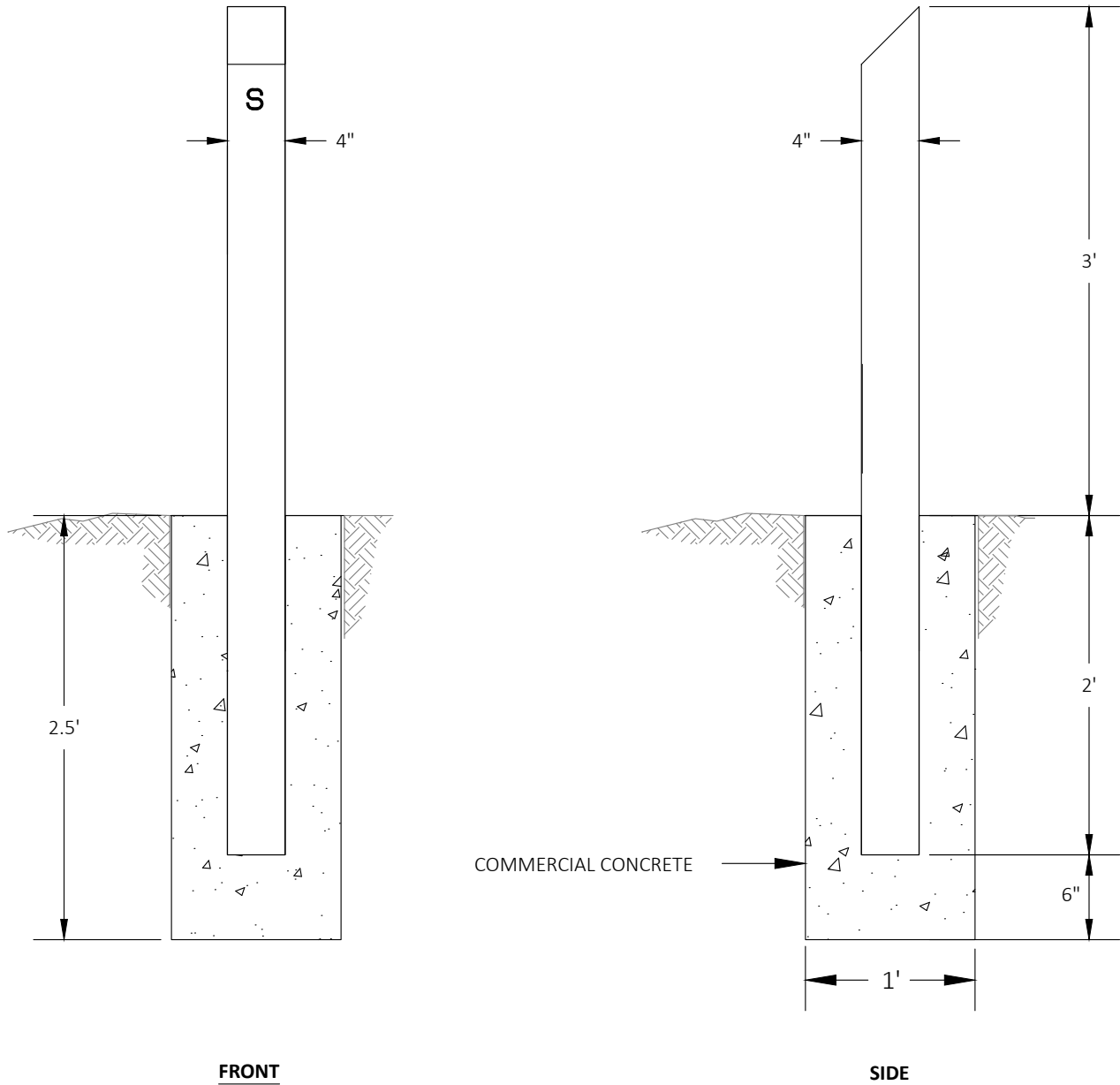

**FRONT**

**SIDE**

**NOTES:**

1. 4" SCHEDULE 40 STEEL OR REINFORCED CONCRETE MARKER POST STAMPED WITH A GREEN "S" AND DISTANCE TO VALVE.
2. THE POST TO BE COATED WITH ONE PRIME COAT AND TWO COATS OF OUTDOOR OIL BASE ENAMEL (WHITE).

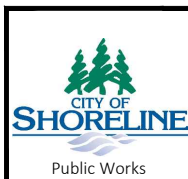

PUBLICATION DATE: <b>3/1/2022</b>	REVISION DATE: <b>4/30/2021</b>
STANDARD DETAIL NUMBER: <b>623</b>	SCALE: <b>NOT TO SCALE</b>
<b>VALVE MARKER DETAIL - SANITARY</b>	

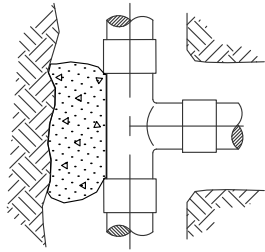

TOP VIEW

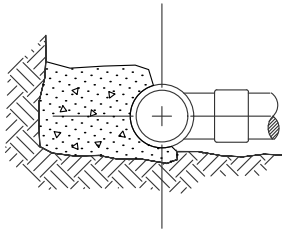

SIDE VIEW

TEE

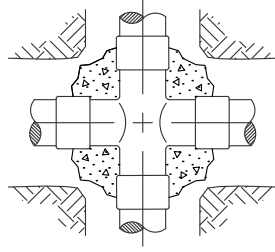

TOP VIEW

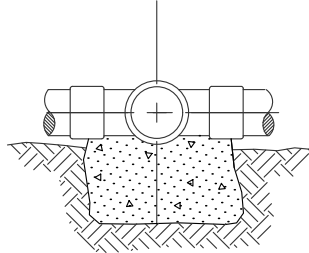

SIDE VIEW

CROSS

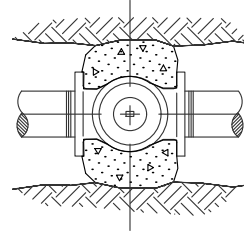

TOP VIEW

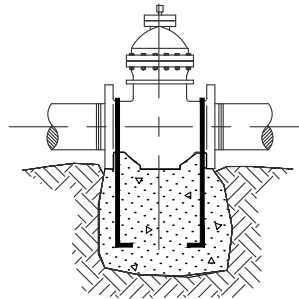

SIDE VIEW

GATE VALVE

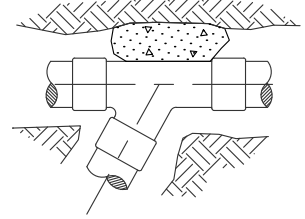

WYE

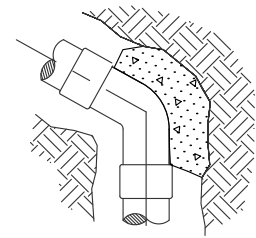

HORIZ. BEND

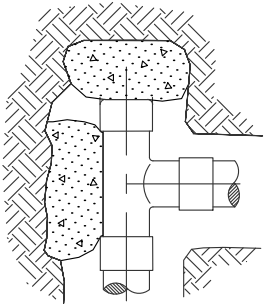

TEE WITH  
PLUG

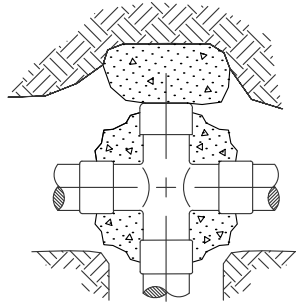

CROSS WITH  
PLUG

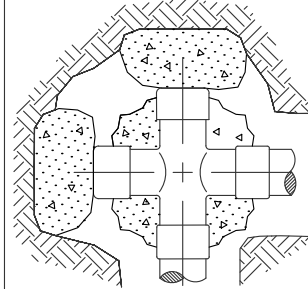

CROSS WITH  
PLUGS

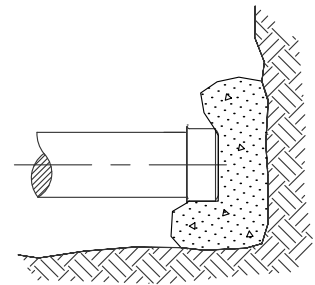

PLUG OR CAP

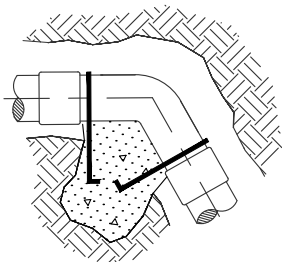

45° - 90°  
VERTICAL BEND

NOTES:

1. CONCRETE THRUST BLOCKING TO BE POURED AGAINST UNDISTURBED EARTH.
2. PLASTIC BARRIER SHALL BE PLACED BETWEEN ALL THRUST BLOCKS AND FITTINGS.
3. ANCHOR REBAR SHALL BE 5/8" MINIMUM DIAMETER.
4. CONCRETE BLOCKING SHALL BE PER APWA SPECIFICATION 7-11.3(13).



PUBLICATION DATE: **3/1/2022**

REVISION DATE: **10/6/2021**

STANDARD DETAIL NUMBER: **624**

SCALE: **NOT TO SCALE**

**THRUST BLOCK-VARIOUS DETAIL -  
SANITARY**

**THRUST LOADS**

THRUST AT FITTINGS IN POUNDS AT 200 POUNDS PER SQUARE INCH OF WATER PRESSURE

PIPE DIAMETER	90° BEND	45° BEND	22-1/2° BEND	11-1/4° BEND	DEAD END OR TEE
4"	3,600	2,000	1,000	500	2,600
6"	8,000	4,400	2,300	1,200	5,700
8"	14,300	7,700	4,000	2,000	10,100
10"	22,300	12,100	6,200	3,100	15,800
12"	32,000	17,400	8,900	4,500	22,700
14"	43,600	23,600	12,100	6,100	30,800
16"	57,000	30,800	15,700	7,900	40,300

**NOTES**

- BLOCKING SHALL BE COMMERCIAL CONCRETE POURED IN PLACE AGAINST UNDISTURBED EARTH. FITTING SHALL BE ISOLATED FROM CONCRETE THRUST BLOCK WITH PLASTIC OR SIMILAR MATERIAL.
- TO DETERMINE THE BEARING AREA OF THE THRUST BLOCK IN SQUARE FEET (SF):  
EXAMPLE : 12" - 90° BEND IN SAND AND GRAVEL 32,000 LBS 3000 LB/SF = 10.7 SF OF AREA.
- AREAS MUST BE ADJUSTED FOR OTHER PIPE SIZE, PRESSURES AND SOIL CONDITIONS.
- BLOCKING SHALL BE ADEQUATE TO WITHSTAND FULL TEST PRESSURE AS WELL AS TO CONTINUOUSLY WITHSTAND OPERATING PRESSURE UNDER ALL CONDITIONS OF SERVICE.

**SAFE SOIL BEARING LOADS**

FOR HORIZONTAL THRUSTS WHEN THE DEPTH OF COVER OVER THE PIPE EXCEEDS 2 FEET

SOIL	POUNDS PER SQUARE FOOT
MUCK, PEAT	0
SOFT CLAY	1,000
SAND	2,000
SAND & GRAVEL	3,000
SAND & GRAVEL CEMENTED WITH CLAY	4,000
HARD SHALE	10,000

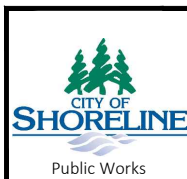

PUBLICATION DATE: **3/1/2022** | REVISION DATE: **4/30/2021**

STANDARD DETAIL NUMBER: **625** | SCALE: **NOT TO SCALE**

**THRUST LOAD CALCULATION -  
SANITARY**

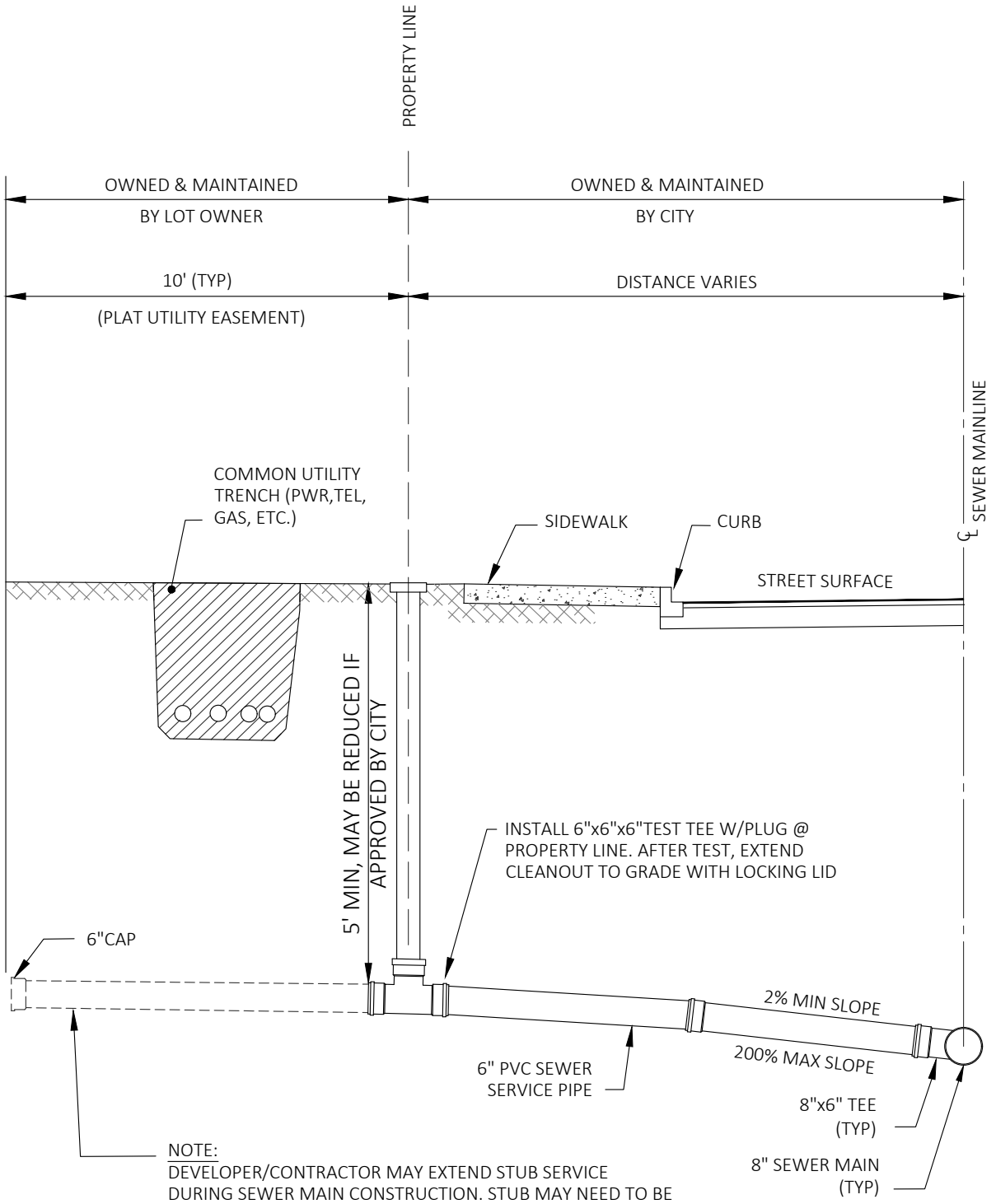

**ELEVATION**

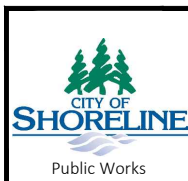

PUBLICATION DATE: **3/1/2022** REVISION DATE: **4/30/2021**

STANDARD DETAIL NUMBER: **626** SCALE: **NOT TO SCALE**

**SIDE SEWER CONNECTION DETAIL - SANITARY**

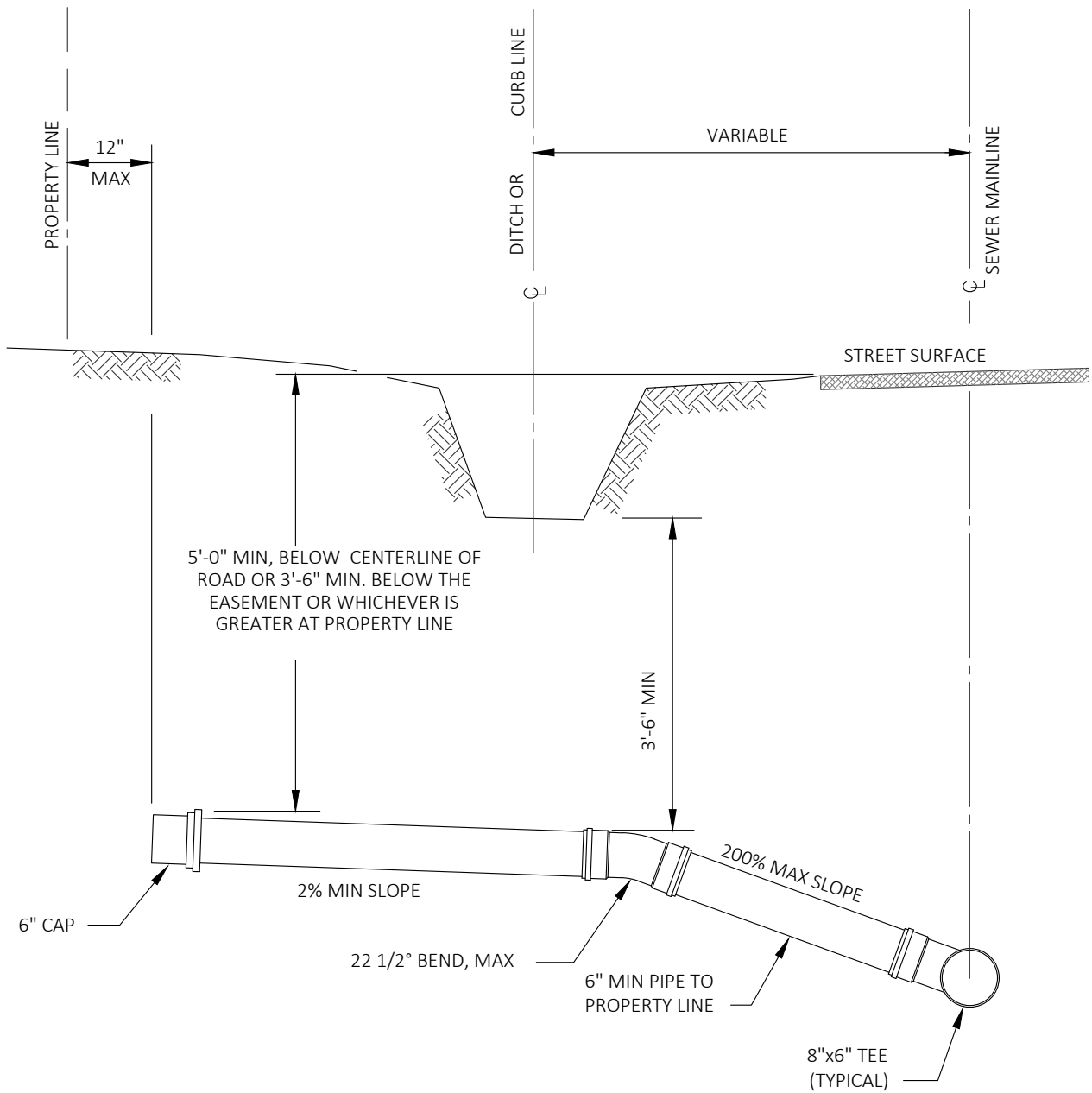

5'-0" MIN, BELOW CENTERLINE OF ROAD OR 3'-6" MIN. BELOW THE EASEMENT OR WHICHEVER IS GREATER AT PROPERTY LINE

3'-6" MIN

2% MIN SLOPE

200% MAX SLOPE

6" CAP

22 1/2° BEND, MAX

6" MIN PIPE TO PROPERTY LINE

8"x6" TEE (TYPICAL)

**ELEVATION**

**NOTE**  
 MAXIMUM ALLOWANCE FOR INSTALLATION IS A 22 1/2° MANUFACTURED BEND.

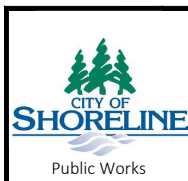

PUBLICATION DATE: <b>3/1/2022</b>	REVISION DATE: <b>4/30/2021</b>
STANDARD DETAIL NUMBER: <b>627</b>	SCALE: <b>NOT TO SCALE</b>
<b>SANITARY SEWER SERVICE - NEW CONSTRUCTION</b>	

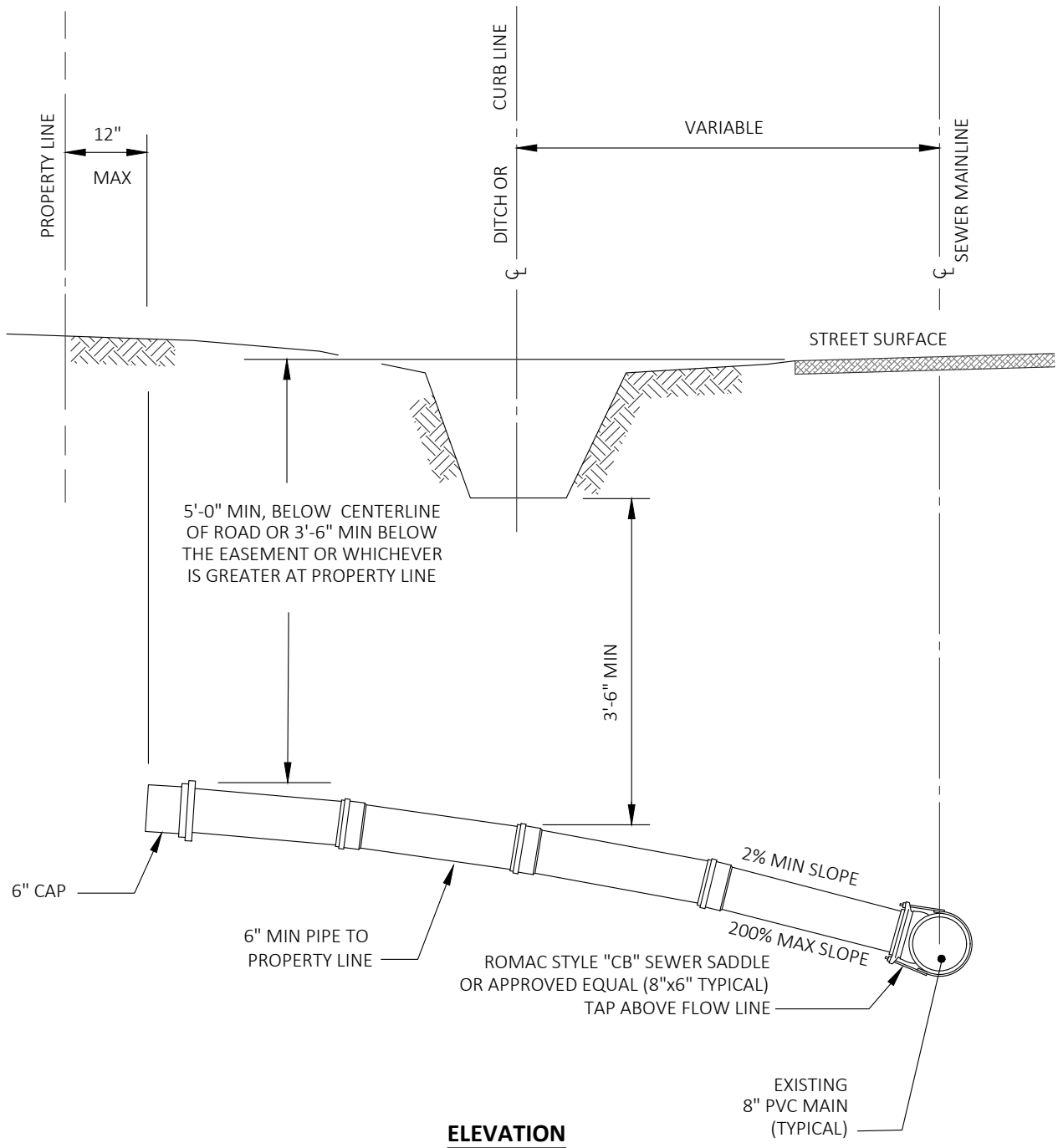

**NOTE:**

MAXIMUM DEFLECTION PER JOINT NOT OVER 2" PER FOOT, OR 5" PER STANDARD 30' PIPE SECTION. (NOT TO EXCEED PIPE MANUFACTURER'S SPECIFICATIONS)

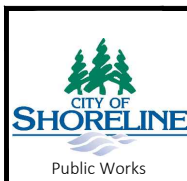

PUBLICATION DATE: **3/1/2022**

REVISION DATE: **4/30/2021**

STANDARD DETAIL NUMBER: **628**

SCALE: **NOT TO SCALE**

**SADDLE CONNECTION TO SEWER MAIN DETAIL - SANITARY**

**SINGLE SERVICE**

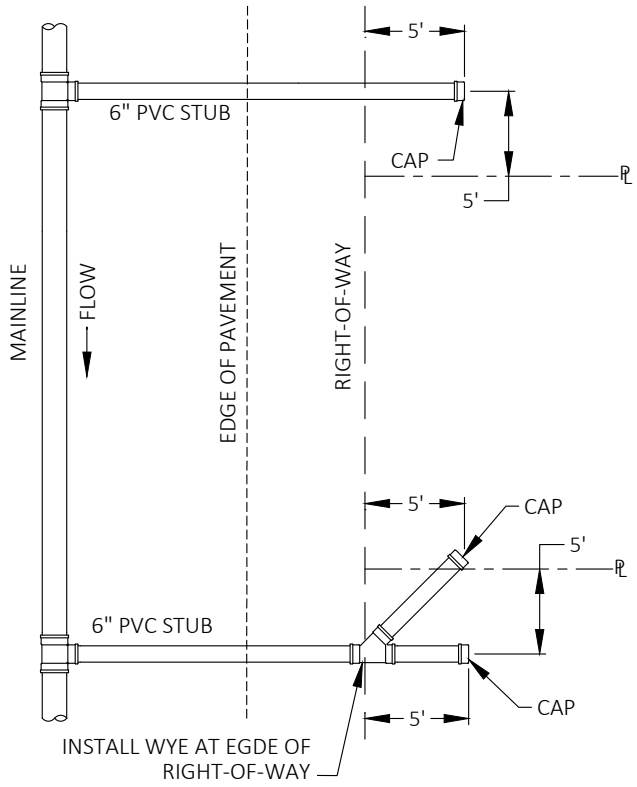

2"X 4" STAKE BURIED AT DEPTH OF PIPE INVERT, PAINTED WHITE ABOVE GROUND EXTEND A MINIMUM OF 3 FEET ABOVE GRADE

MARK 2"X 4" STAKE WITH "SEWER", DEPTH FROM PIPE INVERT TO FINAL GRADE, AND DISTANCE FROM MAIN TO END OF STUB

FOR TRENCH SPECS SEE COS STD 614

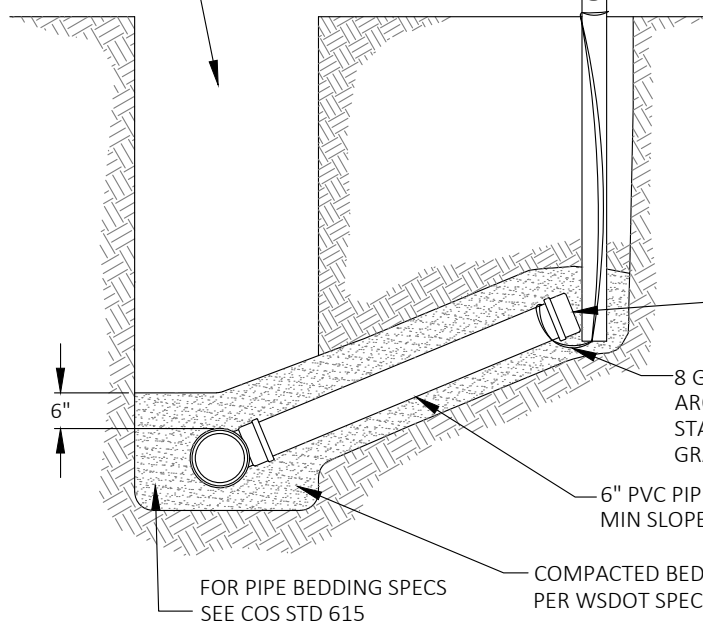

**JOINT USE SERVICE**

**NOTES:**

1. WHERE SIDE SEWER CONNECTS TO MANHOLE: INVERT OF SIDE SEWER SHALL BE EQUAL TO OR ABOVE MAIN SEWER CROWN, BUT NOT TO EXCEED 18" ABOVE INVERT OF MAIN SEWER.
2. UNLESS OTHERWISE INDICATED ON PLAN, SIDE SEWER SHALL BE MINIMUM OF 6' DEEP AT PROPERTY LINE, OR 5' LOWER THAN THE LOWEST ELEVATION, WHICHEVER IS LOWER.
3. PIPE CAN BE REDUCED TO 4" DIAMETER ON PRIVATE PROPERTY.

 CITY OF SHORELINE Public Works	PUBLICATION DATE: <b>3/1/2022</b>	REVISION DATE: <b>4/30/2021</b>
	STANDARD DETAIL NUMBER: <b>629</b>	SCALE: <b>NOT TO SCALE</b>
<b>SANITARY SEWER LATERAL DETAIL</b>		



**SINGLE SERVICE**

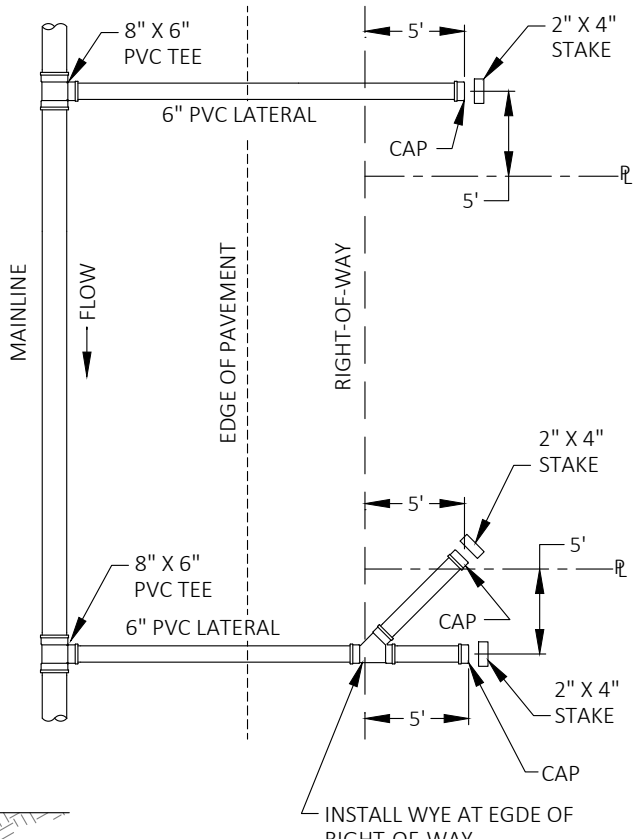

**JOINT USE SERVICE**

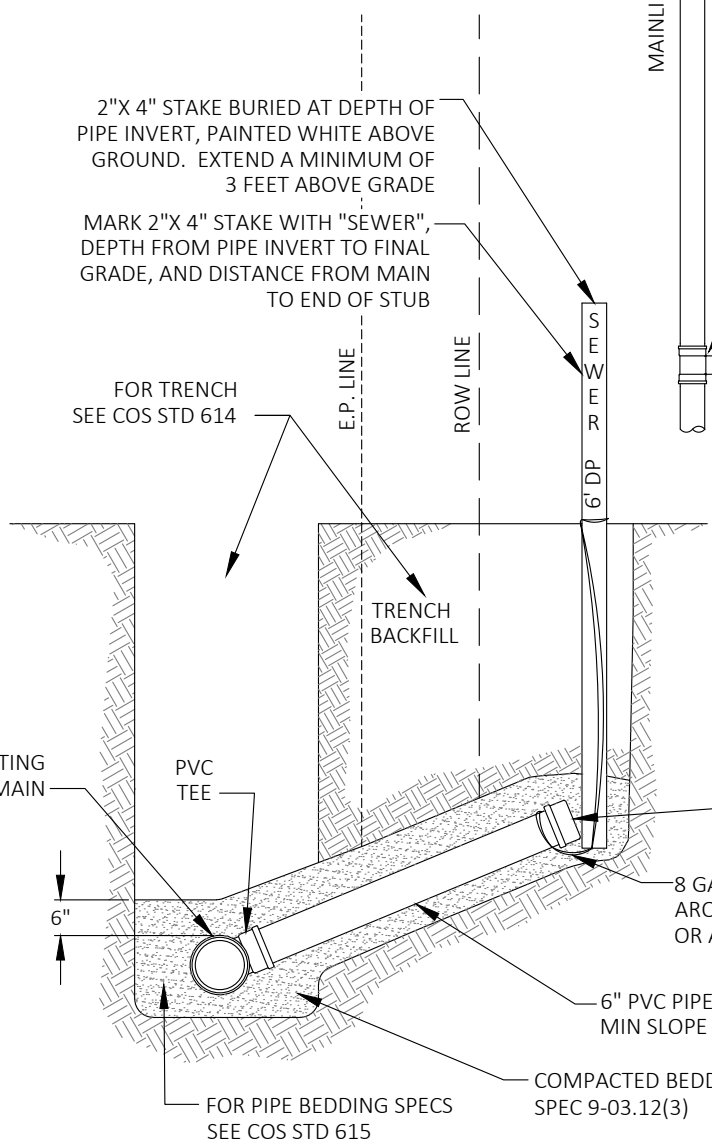

2" X 4" STAKE BURIED AT DEPTH OF PIPE INVERT, PAINTED WHITE ABOVE GROUND. EXTEND A MINIMUM OF 3 FEET ABOVE GRADE

MARK 2" X 4" STAKE WITH "SEWER", DEPTH FROM PIPE INVERT TO FINAL GRADE, AND DISTANCE FROM MAIN TO END OF STUB

FOR TRENCH SEE COS STD 614

E.P. LINE

ROW LINE

TRENCH BACKFILL

EXISTING PVC MAIN

PVC TEE

6"

GASKETED CAP

8 GAUGE WIRE TO BE DOUBLED AROUND PIPE AND 2" X 4" STAKE AT OR ABOVE FINAL GRADE

6" PVC PIPE MIN SLOPE 2%

FOR PIPE BEDDING SPECS SEE COS STD 615

COMPACTED BEDDING GRAVEL PER WSDOT SPEC 9-03.12(3)

**NOTES:**

1. WHERE SIDE SEWER CONNECTS TO MANHOLE: INVERT OF SIDE SEWER SHALL BE EQUAL TO OR ABOVE MAIN SEWER CROWN, BUT NOT TO EXCEED 18" ABOVE INVERT OF MAIN SEWER.
2. UNLESS OTHERWISE INDICATED ON PLAN, SIDE SEWER SHALL BE MINIMUM OF 6' DEEP AT PROPERTY LINE, OR 5' LOWER THAN THE LOWEST ELEVATION, WHICHEVER IS LOWER.
3. PIPE CAN BE REDUCED TO 4" DIAMETER ON PRIVATE PROPERTY.



PUBLICATION DATE: <b>3/1/2022</b>	REVISION DATE: <b>4/30/2021</b>
STANDARD DETAIL NUMBER: <b>630</b>	SCALE: <b>NOT TO SCALE</b>
<b>STUB LATERAL TO PVC CONNECTION - SANITARY</b>	

**SINGLE SERVICE**

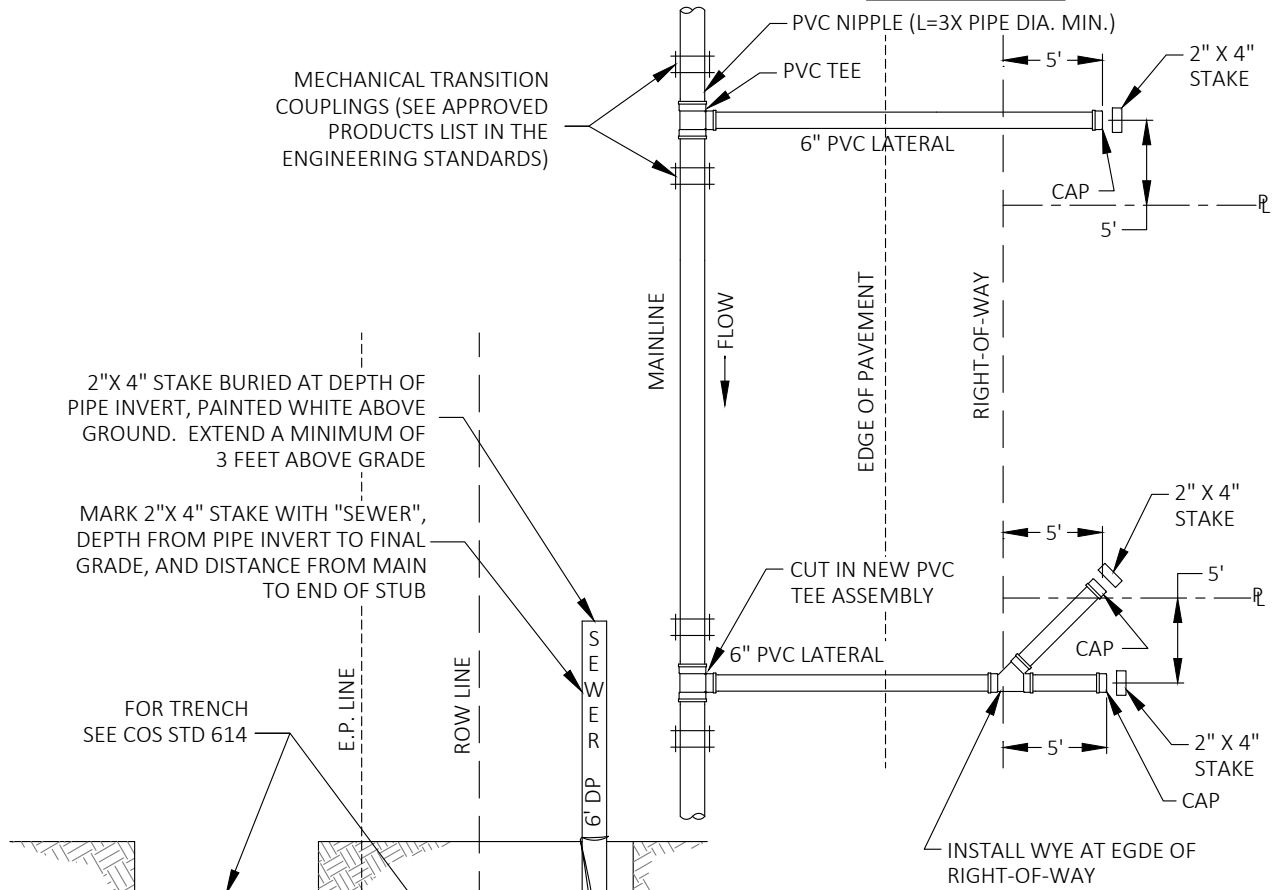

**JOINT USE SERVICE**

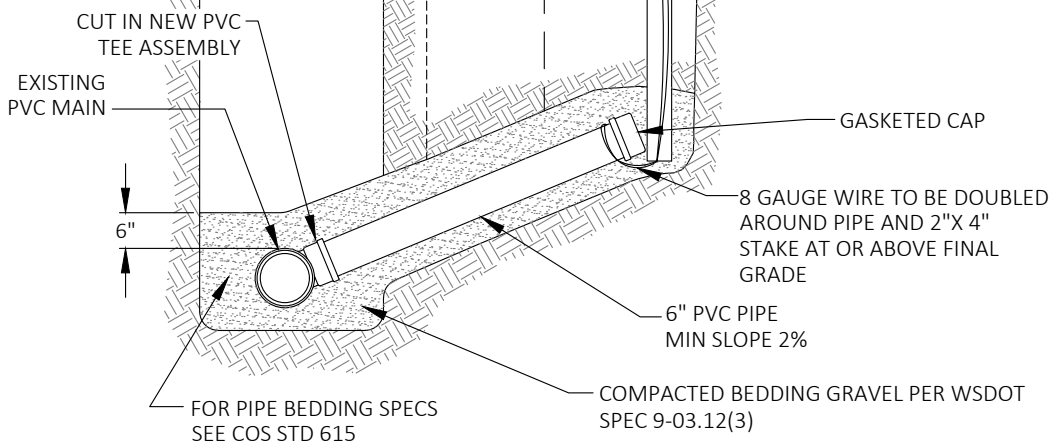

**NOTES:**

1. WHERE SIDE SEWER CONNECTS TO MANHOLE: INVERT OF SIDE SEWER SHALL BE EQUAL TO OR ABOVE MAIN SEWER CROWN, BUT NOT TO EXCEED 18" ABOVE INVERT OF MAIN SEWER.
2. UNLESS OTHERWISE INDICATED ON PLAN, SIDE SEWER SHALL BE MINIMUM OF 6' DEEP AT PROPERTY LINE, OR 5' LOWER THAN THE LOWEST ELEVATION, WHICHEVER IS LOWER.
3. PIPE CAN BE REDUCED TO 4" DIAMETER 10' BEYOND THE ROW LINE.
4. SEWER BYPASS PLAN MUST BE APPROVED BY UTILITIES PRIOR TO BEGINING EXCAVATION.



PUBLICATION DATE: <b>3/1/2022</b>	REVISION DATE: <b>4/30/2021</b>
STANDARD DETAIL NUMBER: <b>631</b>	SCALE: <b>NOT TO SCALE</b>

**SANITARY SEWER LATERAL PVC  
DETAIL**

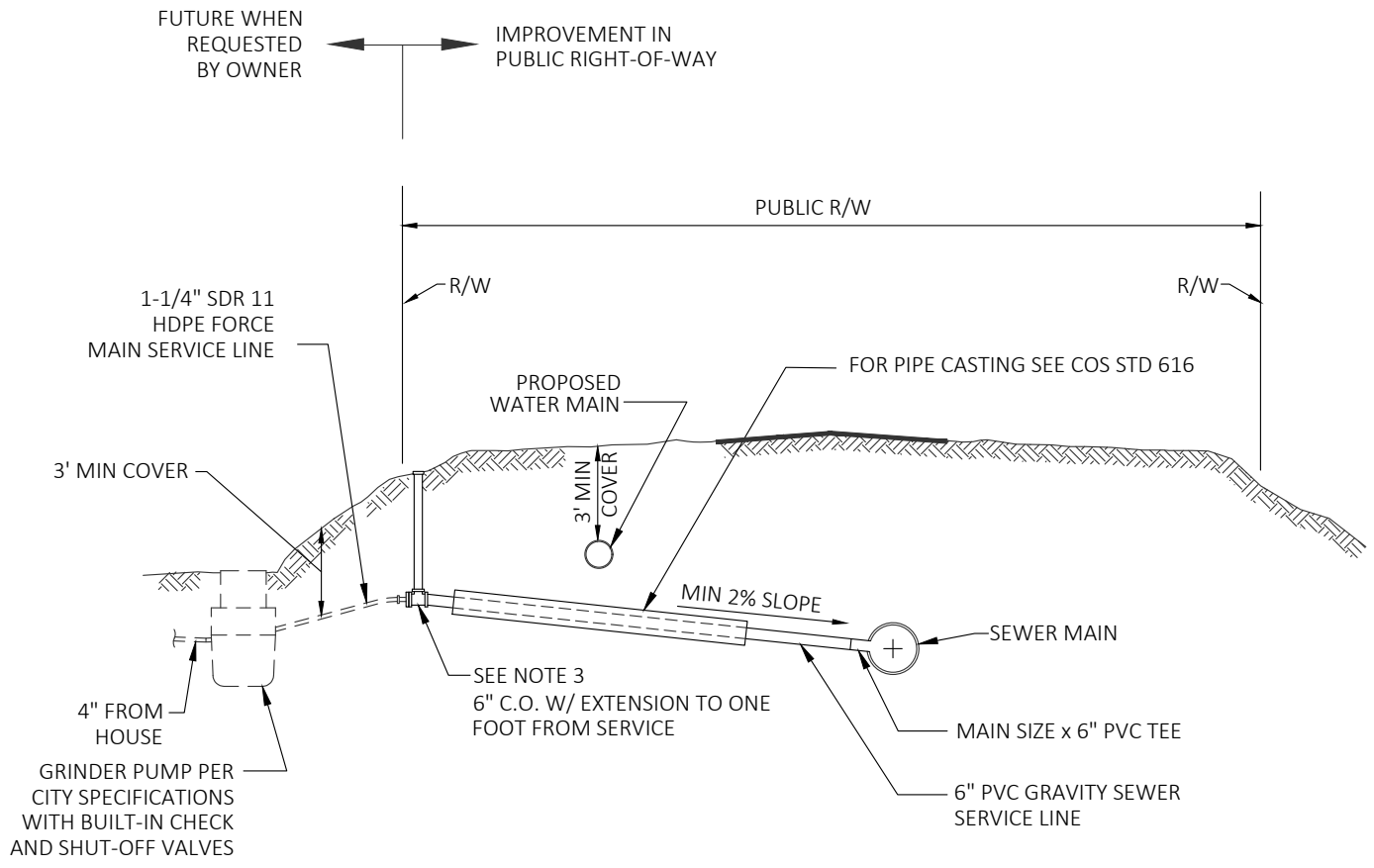

**NOTES**

1. INSTALL 12-GAUGE SOLID COPPER TRACER WIRE ALONG TOP OF 6" GRAVITY SEWER SERVICE LINE AND HDPE FORCE MAIN SERVICE LINE WITH WARNING TAPE MARKED "SEWER" 12" ABOVE SERVICE LINE. TRACER WIRE SHALL EXTEND FROM 6" TEE AT RIGHT-OF-WAY LINE TEE TO GRINDER PUMP. TRACER WIRE SHALL TERMINATE AT GRINDER PUMP LID WITH 24" OF EXTRA COIL.
2. THE LOCATION OF THE STUB SERVICE TERMINATION SHALL BE MARKED BY THE CONTRACTOR WITH 2"x4" TIMBER EXTENDED VERTICALLY FROM THE PLUG END TO A MINIMUM OF 12" ABOVE THE GROUND SURFACE. A 12-GAUGE GALVANIZED WIRE SHALL BE ATTACHED TO THE TIMBER FROM END TO END. NEITHER THE WIRE NOR THE 2"x4" SHALL BE SECURED OR ATTACHED TO THE SEWER PIPE OR PLUG. THE EXPOSED PORTION OF THE 2"x4" SHALL BE PRE-PAINTED TRAFFIC WHITE WITH THE WORDS "GRINDER PUMP SEWER CONNECTION" STENCILED ON WITH BLACK PAINT. THE END OF THE 2"x4" SHALL BE PRE-MARKED IN PERMANENT INK WITH THE LENGTH OF THE TIMBER INSTALLED.
3. 6" TEE AT PROPERTY LINE x 6" CLEANOUT WITH LOCKING LID AND TAPPED 1-1/4" FIPT.

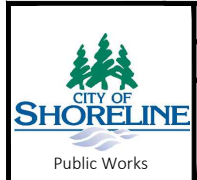

PUBLICATION DATE: <b>3/1/2022</b>	REVISION DATE: <b>10/6/2021</b>
STANDARD DETAIL NUMBER: <b>633</b>	SCALE: <b>NOT TO SCALE</b>
<b>GRINDER PUMP TO GRAVITY MAIN DETAIL - SANITARY</b>	

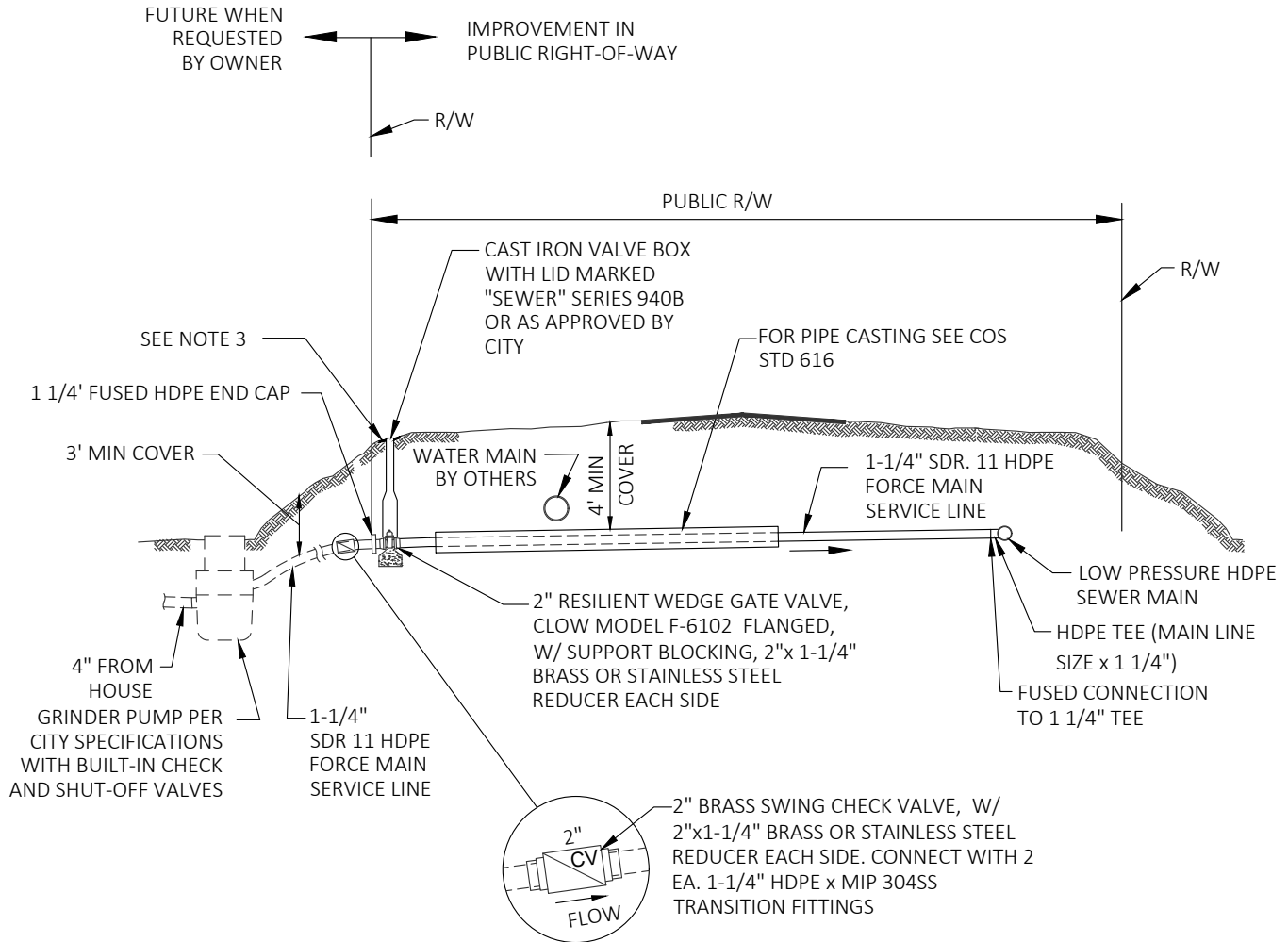

**NOTES:**

1. INSTALL 12-GAUGE SOLID COPPER TRACER WIRE ALONG TOP OF HDPE FORCE MAIN SERVICE LINE WITH WARNING TAPE MARKED "SEWER" 12" ABOVE SERVICE LINE. TRACER WIRE SHALL EXTEND FROM LOW PRESSURE SEWER MAIN TO VALVE AT RIGHT-OF-WAY LINE AND FROM GATE VALVE TO GRINDER PUMP. TRACER WIRE SHALL TERMINATE IN VALVE CAN WITH EXTRA 24" OF COIL AND TERMINATE AT GRINDER PUMP LID.
2. THE LOCATION OF THE STUB SERVICE TERMINATION SHALL BE MARKED BY THE CONTRACTOR WITH 2"x4" TIMBER EXTENDED VERTICALLY FROM THE PLUG END TO A MINIMUM OF 12" ABOVE THE GROUND SURFACE. A 12-GAUGE GALVANIZED WIRE SHALL BE ATTACHED TO THE TIMBER FROM END TO END. NEITHER THE WIRE NOR THE 2"x4" SHALL BE SECURED OR ATTACHED TO THE SEWER PIPE OR PLUG. THE EXPOSED PORTION OF THE 2"x4" SHALL BE PRE-PAINTED TRAFFIC WHITE WITH THE WORDS "GRINDER PUMP SEWER CONNECTION" STENCILED ON WITH BLACK PAINT. THE END OF THE 2"x4" SHALL BE PRE-MARKED IN PERMANENT INK WITH THE LENGTH OF THE TIMBER INSTALLED.
3. INSTALL A 2 FOOT SQUARE x 4" THICK ASPHALT OR CONCRETE PAD AROUND THE VALVE BOX AT ALL VACANT LOTS.

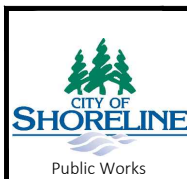

PUBLICATION DATE: **3/1/2022** REVISION DATE: **10/6/2021**

STANDARD DETAIL NUMBER: **634** SCALE: **NOT TO SCALE**

**GRINDER PUMP TO FORCE MAIN CONNECTION - SANITARY**

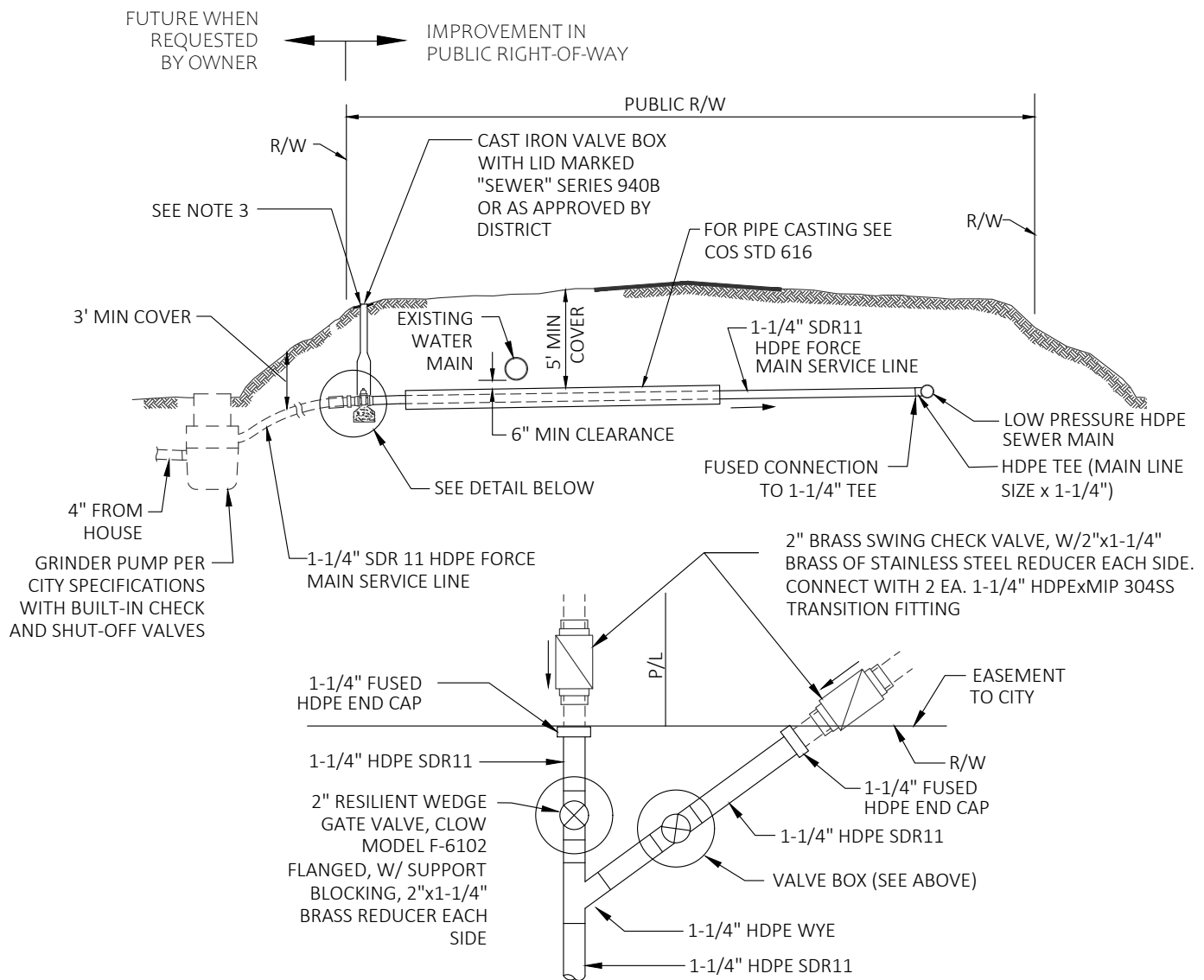

**DOUBLE SERVICE DETAIL**

**NOTES:**

1. INSTALL 12-GAUGE SOLID COPPER TRACER WIRE ALONG TOP OF HDPE FORCE MAIN SERVICE LINE WITH WARNING TAPE MARKED "SEWER" 12" ABOVE SERVICE LINE. TRACER WIRE SHALL EXTEND FROM LOW PRESSURE SEWER MAIN TO VALVE AT RIGHT-OF-WAY LINE AND FROM GATE VALVE TO GRINDER PUMP. TRACER WIRE SHALL TERMINATE IN VALVE CAN WITH EXTRA 24" OF COIL AND TERMINATE AT GRINDER PUMP LID.
2. THE LOCATION OF THE STUB SERVICE TERMINATION SHALL BE MARKED BY THE CONTRACTOR WITH 2"x4" TIMBER EXTENDED VERTICALLY FROM THE PLUG END TO A MINIMUM OF 12" ABOVE THE GROUND SURFACE. A 12-GAUGE GALVANIZED WIRE SHALL BE ATTACHED TO THE TIMBER FROM END TO END. NEITHER THE WIRE NOR THE 2"x4" SHALL BE SECURED OR ATTACHED TO THE SEWER PIPE OR PLUG. THE EXPOSED PORTION OF THE 2"x4" SHALL BE PRE-PAINTED TRAFFIC WHITE WITH THE WORDS "GRINDER PUMP SEWER CONNECTION" STENCILED ON WITH BLACK PAINT. THE END OF THE 2"x4" SHALL BE PRE-MARKED IN PERMANENT INK WITH THE LENGTH OF THE TIMBER INSTALLED.
3. INSTALL A 2 FOOT SQUARE x 4" THICK ASPHALT OR CONCRETE PAD AROUND THE VALVE BOX AT ALL VACANT LOTS. LOTS WITH EXISTING HOMES WILL HAVE PAD INSTALLED BY THE DISTRICT AFTER GRINDER PUMP CONNECTION IS COMPLETED.



PUBLICATION DATE: **3/1/2022** REVISION DATE: **10/6/2021**

STANDARD DETAIL NUMBER: **635** SCALE: **NOT TO SCALE**

**DUAL GRINDER PUMP TO LOW PRESSURE FORCE MAIN**

**MATERIALS LIST**

1. SDR-11 1 1/4" HDPE PIPE, DR11-55.
2. TRACER WIRE (16 GAUGE SOLID COPPER), NO. W114BLK-500 OREQUAL.
3. 1 1/4" HDPE BUTT FUSED JOINT.
4. 6" MJ CAP TAPPED 1 1/4" OR 2" IP WITH MJ KIT NO. IFD2MX5L.
5. 6" x 1 1/4" STAINLESS STEEL OR BRASS BUSHING.
6. CONFIRM GASKET NECESSARY TO INSTALL 6" MJ CAP TO SDR21 SEWER PIPE WITH SUPPLIER.

**SUPPLIER**

HD FOWLER CO.                      OR                      CORRECT EQUIPMENT

(THERE ARE OTHER SUPPLIERS THAT MAY CARRY THESE PARTS)

NOTE: GRINDER PUMP UNIT SHALL BE "ENVIRONMENT ONE".  
MODEL # TO BE CONFIRMED BY CITY.

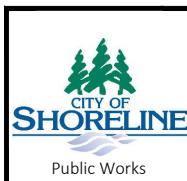

PUBLICATION DATE: <b>3/1/2022</b>	REVISION DATE: <b>4/30/2021</b>
STANDARD DETAIL NUMBER: <b>636</b>	SCALE: <b>NOT TO SCALE</b>

**GRINDER PUMP INSTALLATION  
DETAIL - SANITARY**

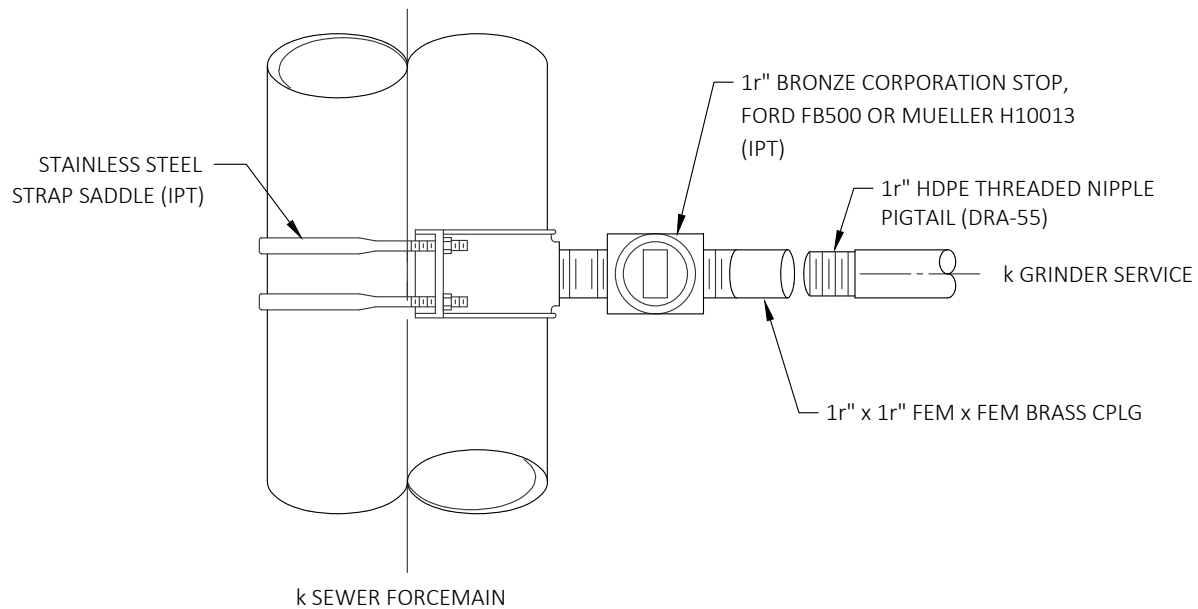

**PLAN**

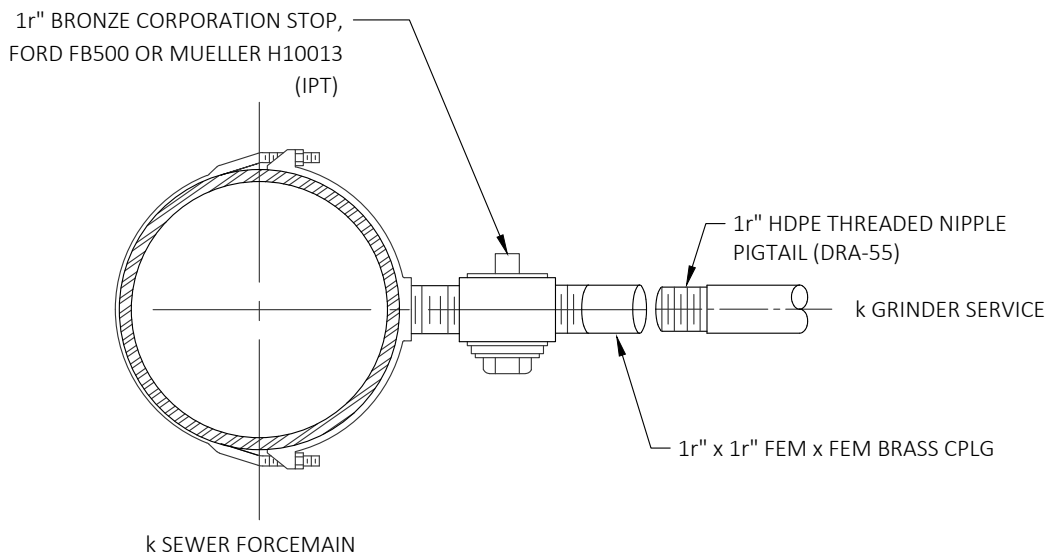

**ELEVATION**

**NOTE**

1. GRINDER LINE FITTINGS: ALL FITTINGS SHALL BE CAST FROM WATER WORKS BRASS CONFORMING TO C800-89.
2. MUNICIPAL SERVICE PIPE: IRON PIPE SIZE SDR 11 WITH TRACER WIRE AND WARNING TAPE MARKED "SEWER" 12" ABOVE.
3. FOR HDPE FORCE MAIN, USE SPRING WASHERS ON SADDLE.

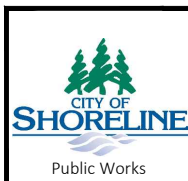

PUBLICATION DATE: **3/1/2022** REVISION DATE: **4/30/2021**

STANDARD DETAIL NUMBER: **637** SCALE: **NOT TO SCALE**

**GRINDER PUMP CONNECTION TO FORCEMAIN - SANITARY**

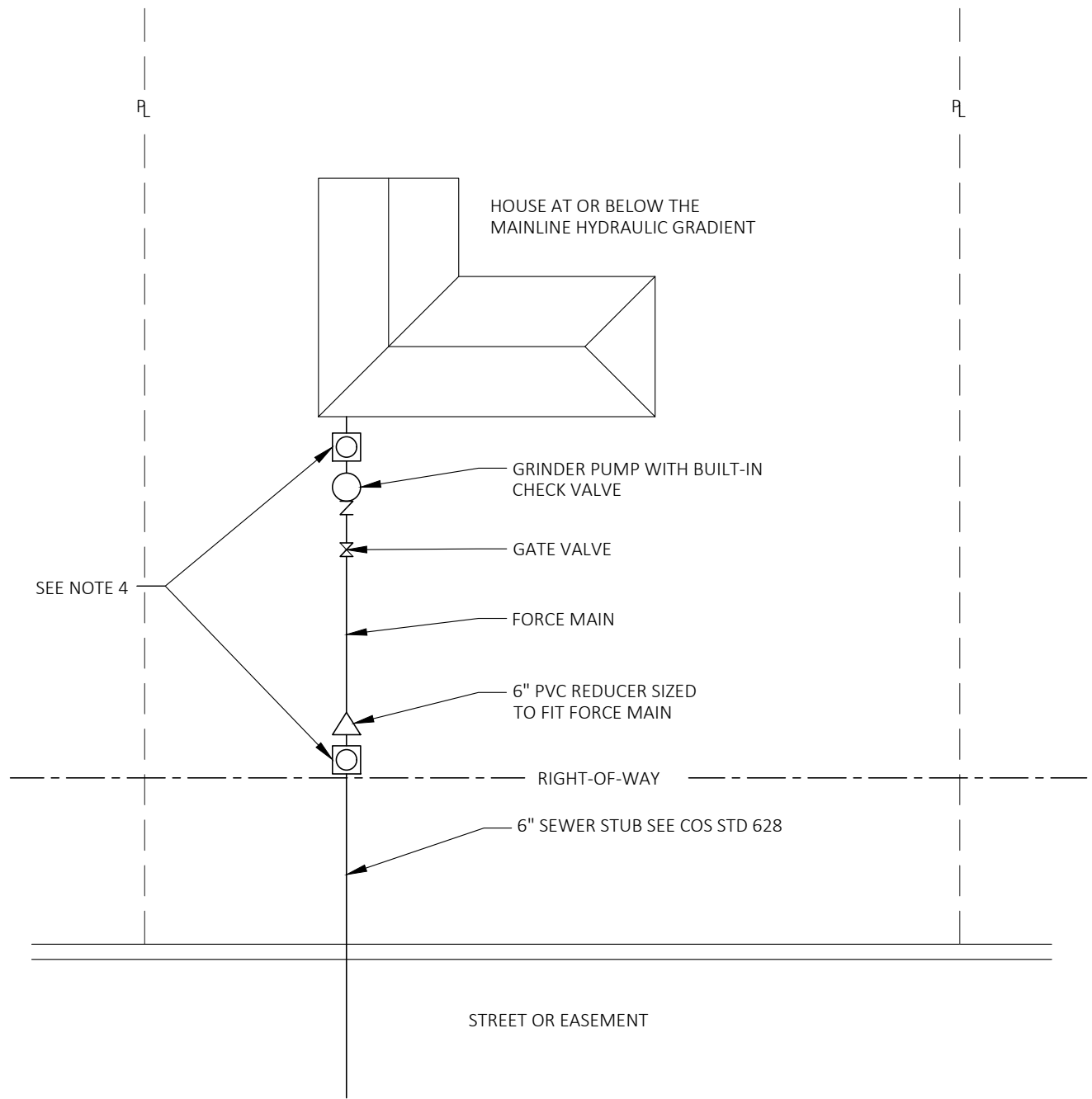

**NOTES:**

1. PUMP SHALL NOT BE CONNECTED TO A SEPTIC TANK OF ANY SIZE.
2. CHECK VALVES AND PUMP ASSEMBLIES ARE PRIVATE AND SHALL BE THE PROPERTY OWNERS RESPONSIBILITY TO MAINTAIN.
3. PUMP BASIN SYSTEM SHALL BE DESIGNED BY THE PUMP MANUFACTURER.
4. ALL CLEANOUTS SHALL BE INSTALLED TO GRADE PER COS STD 645.
5. FORCE MAIN TO 6" GRAVITY STUB CONNECT MUST BE MADE WITH PVC REDUCER, NOT FLEXIBLE COUPLING.
6. FORCE MAIN TESTING SHALL BE IN ACCORDANCE WITH SECTION 7-17.3 OF THE WSDOT STANDARD SPECIFICATIONS.

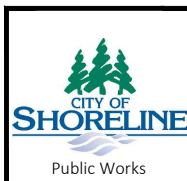

PUBLICATION DATE: <b>3/1/2022</b>	REVISION DATE: <b>4/30/2021</b>
STANDARD DETAIL NUMBER: <b>638</b>	SCALE: <b>NOT TO SCALE</b>

## GRINDER PUMP SYSTEM SCHEMATIC



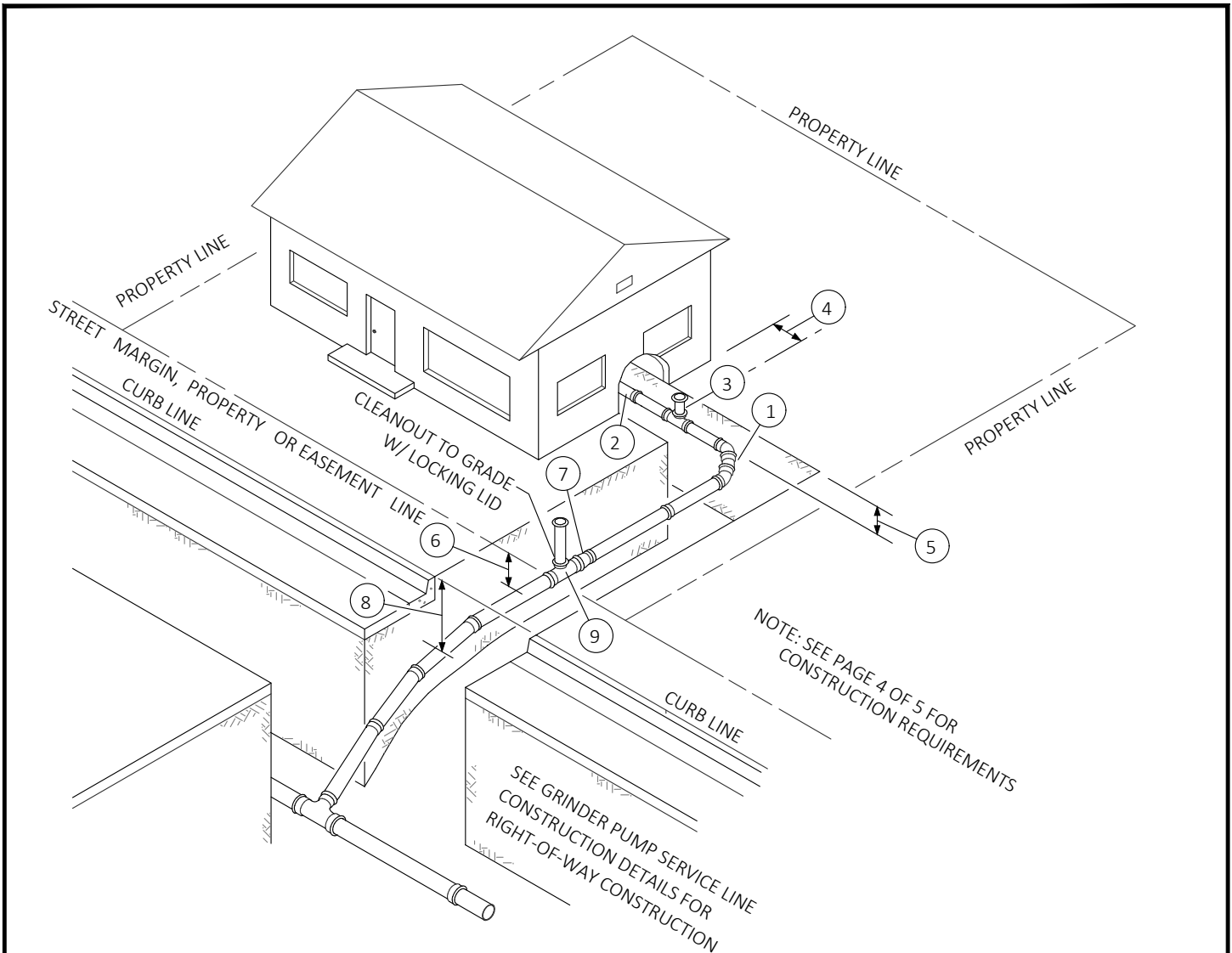

**NOTES**

- ① 2 - 45° BENDS WITH 24" MIN SEPARATION BETWEEN BENDS TO EQUAL 90° BEND.
- ② CONNECTION TO MAIN STACK FROM SIDE SEWER SHALL BE DUCTILE IRON OR PVC PIPE WITH STRONGBACK FERNCO COUPLING OR EQUAL.
- ③ 4" WYE OR TEE WITH CLEANOUT EXTENDED TO SURFACE.
- ④ 18" MINIMUM OR 30" MAXIMUM DISTANCE FROM HOUSE. IF ACCESS IS PREVENTED BY PORCH OR DECKS, THEN SURFACE CLEAN-OUT IS REQUIRED (SEE DETAIL NO. 30).
- ⑤ 18" MINIMUM COVER.
- ⑥ 5'-0" MINIMUM BELOW STREET CENTERLINE OR 3'-6" MINIMUM BELOW EASEMENT LINE ELEVATION, WHICHEVER IS DEEPER @ THE PROPERTY OR EASEMENT LINE.
- ⑦ STANDARD 4" TO 6" INCREASER.
- ⑧ 6'-0" MINIMUM BELOW ROAD GRADE OR CURB LINE.
- ⑨ 6"x6"x6" TEST TEE SHALL BE LOCATED INSIDE PRIVATE PROPERTY.

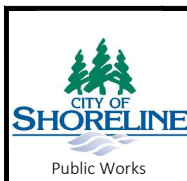

PUBLICATION DATE: <b>3/1/2022</b>	REVISION DATE: <b>4/30/2021</b>
STANDARD DETAIL NUMBER: <b>639</b>	SCALE: <b>NOT TO SCALE</b>
<b>HOUSE LATERAL CONNECTION TO GRAVITY MAIN - SANITARY</b>	

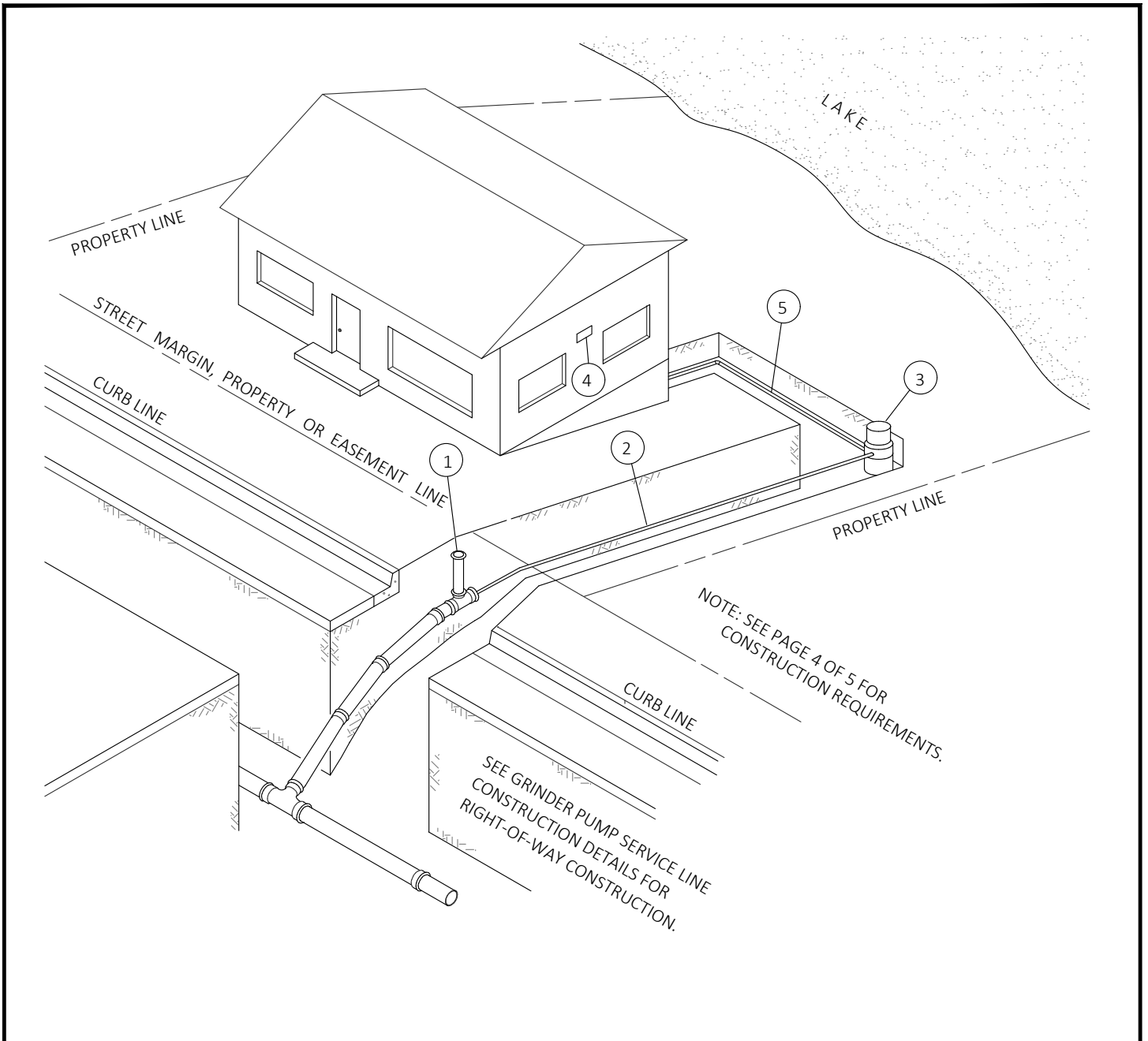

**NOTES**

- ① 6" TEE x MJ TAPPED WITH 1-1/4" NPT. EXTEND CLEANOUT PIPE TO SURFACE WITH LOCKING LID AFTER TESTING.
- ② 1-1/4" HDPE ON-SITE SERVICE LINE WITH 16-GAUGE SOLID COPPER TRACER WIRE ALONG TOP OF HDPE FORCE MAIN AND WARNING TAPE MARKED "SEWER" 12" ABOVE.
- ③ GRINDER PUMP.
- ④ PUMP CONTROL PANEL WITH ALARM LIGHT. LOCATION MUST BE IN DIRECT LINE OF SIGHT FROM GRINDER PUMP, 3' MIN, 5' MAX ABOVE GROUND. CONTROL WIRE TO BE PLACED IN 1" MIN. CONDUIT FROM PANEL TO GRINDER PUMP.
- ⑤ GRAVITY HOUSE SERVICE TO GRINDER PUMP.
- ⑥ CONTACT THE CITY TO SCHEDULE AN ON-SITE PRECONSTRUCTION MEETING PRIOR TO ANY WORK.

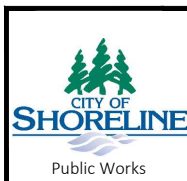

PUBLICATION DATE: <b>3/1/2022</b>	REVISION DATE: <b>4/30/2021</b>
STANDARD DETAIL NUMBER: <b>640</b>	SCALE: <b>NOT TO SCALE</b>
<b>HOUSE CONNECTION TO GRINDER PUMP - SANITARY</b>	

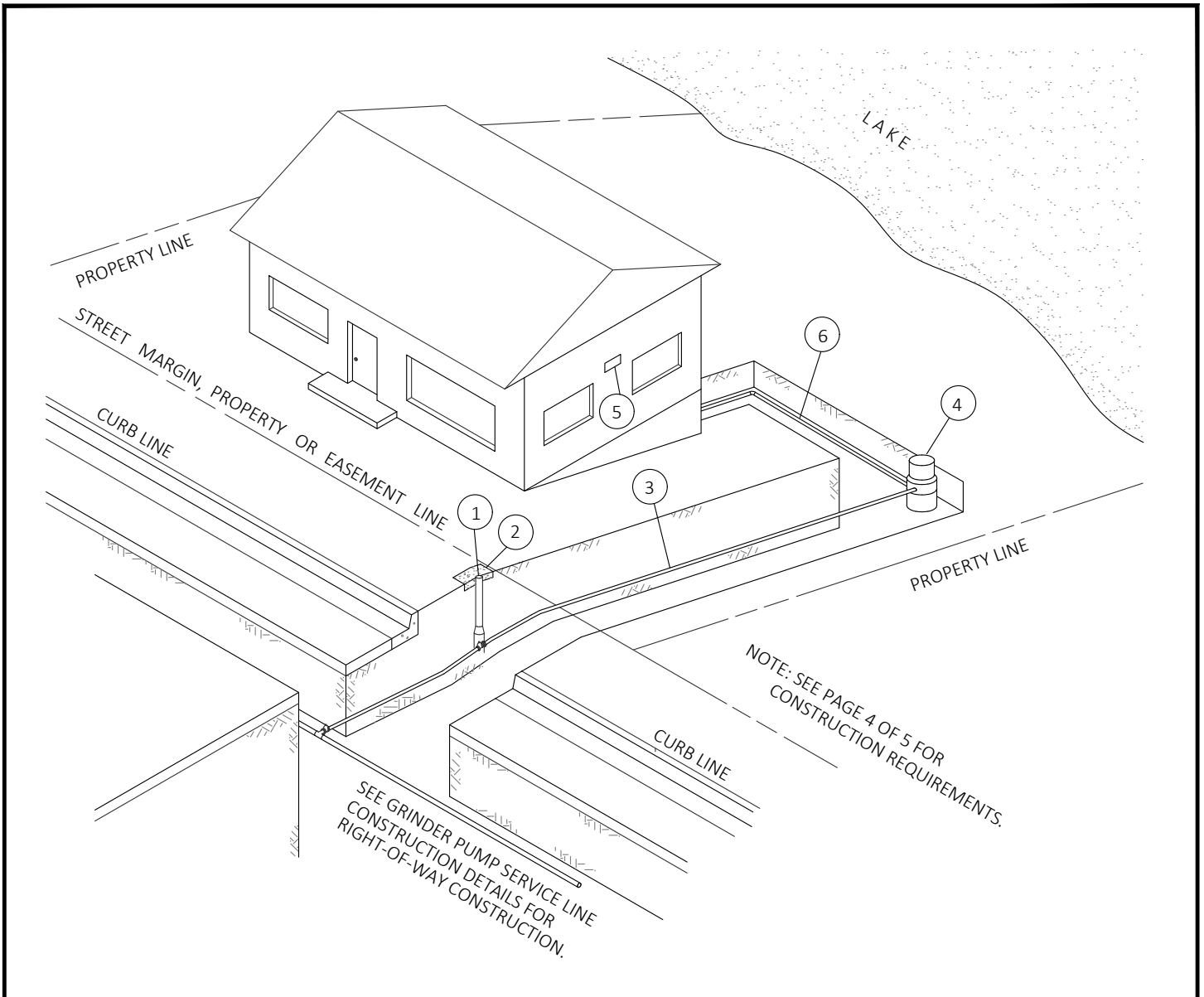

NOTES:

- ① CAST IRON VALVE BOX WITH LID MARKED "SEWER" SERIES 940B OR AS APPROVED BY CITY.
- ② INSTALL A 2 FOOT X 4 INCH THICK ASPHALT OR CONCRETE PAD AROUND THE VALVE BOX.
- ③ 1¼" HDPE ON-SITE SERVICE LINE WITH 16-GAUGE SOLID COPPER TRACER WIRE ALONG TOP OF HDPE FORCE MAIN AND WARNING TAPE MARKED "SEWER" 12" ABOVE LINE.
- ④ E/ONE EXTREME GRINDER MODEL #DH 071 WITH 70 GALLON CAPACITY. IF MORE CAPACITY IS DESIRED A MODEL #DH 151 WITH A 150 GALLON CAPACITY WILL BE ACCEPTED.
- ⑤ SENTRY CONTROL PANEL #SA1A01B1AA MUST BE LOCATED IN DIRECT LINE OF SITE FROM THE GRINDER PUMP 3 FT. MIN 5 FT. MAX ABOVE GROUND. CONTROL WIRE SHALL BE RUN UNSPLICED (ORDER LENGTH AS NEEDED) AND PLACED IN 1 INCH MIN CONDUIT FROM PANEL TO GRINDER PUMP. IF CABLE LONGER THAN 100 FT. IS NEEDED AND SPLICING IS NECESSARY, DISTRICT APPROVAL IS REQUIRED FOR SPECIAL SPLICING REQUIREMENTS. ALL CONTROL PANEL WIRING SHALL BE PER MANUFACTURERS WIRING DIAGRAM LOCATED INSIDE THE DOOR OF CONTROL PANEL.
- ⑥ GRAVITY HOUSE SERVICE TO GRINDER PUMP.
- ⑦ CONTACT THE CITY TO SCHEDULE AN ON-SITE PRECONSTRUCTION MEETING PRIOR TO BEGINNING ANY WORK.

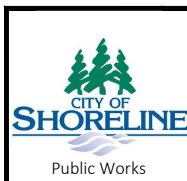

PUBLICATION DATE: <b>3/1/2022</b>	REVISION DATE: <b>4/30/2021</b>
STANDARD DETAIL NUMBER: <b>641</b>	SCALE: <b>NOT TO SCALE</b>
<b>HOUSE CONNECTION W-GRINDER PUMP TO GRAVITY MAIN - SANITARY</b>	

**CONSTRUCTION REQUIREMENTS ( STUB SERVICE )**

(TO BE CONSTRUCTED BY CITY OR DEVELOPER AS PART OF THE PROJECT)

1. 6" SEWER PIPE REQUIRED IN STREET AT 2% MIN GRADE AND 200% MAXIMUM GRADE.
2. JOINTS MUST BE MADE W/RUBBER TYPE GASKET AS APPROVED BY CITY.
3. ALL STUB SERVICES SHALL BE TESTED IN ACCORDANCE WITH THE CITY'S SPECIFICATIONS PRIOR TO APPROVAL.
4. ALL MATERIALS USED IN THE CONSTRUCTION OF ANY STUB SERVICE SHALL HAVE PRIOR APPROVAL OF THE CITY.
5. ALL CONSTRUCTION OF STUB SERVICES MUST COMPLY WITH CITY SIDE SEWER REGULATIONS.

**CONSTRUCTION REQUIREMENTS ( SIDE SEWER )**

(TO BE CONSTRUCTED BY PROPERTY OWNER AFTER COMPLETION OF PROJECT)

1. SIDE SEWER SHALL BE CONNECTED TO STUB SERVICE WITH A 6"x6"x6" CLEANOUT TO GRADE WITH LOCKING LID AND 6"x4" REDUCER, BY PROPERTY OWNER.
2. 4" MIN SEWER PIPE REQUIRED ON PROPERTY. PERMIT REQUIRED.
3. 6" MIN SEWER PIPE REQUIRED ON PROPERTY, FOR JOINT SIDE SEWERS. PERMIT AND JOINT SIDE SEWER EASEMENT AGREEMENT REQUIRED.
4. 2% MIN GRADE (1/4" FALL PER FOOT); 200% MAXIMUM GRADE (24" FALL PER FOOT).
5. JOINTS MUST BE MADE W/RUBBER TYPE GASKET, APPROVED BY CITY.
6. SEE GENERAL NOTES, PAGE 1 OF 5 - TYPICAL HOUSE CONNECTION.
7. CONSTRUCTION ON PRIVATE PROPERTY MAY BE DONE BY OWNER, BUT REQUIRES A PERMIT.
8. ALL MATERIALS USED IN THE CONSTRUCTION OF ANY SIDE SEWER SHALL HAVE PRIOR APPROVAL OF CITY. PIPE TO BE CLASS 50 DUCTILE IRON, OR ASTM D-3034, SDR 35 PVC, OR SDR 11 HDPE FOR ALTERNATIVE SEWER SERVICE.
9. ALL SIDE SEWERS SHALL BE TESTED IN ACCORDANCE WITH THE CITY'S SPECIFICATIONS PRIOR TO APPROVAL BY CITY.
10. CONNECTIONS SHALL BE COMPLETE AT BOTH ENDS BEFORE CALLING FOR INSPECTION.
11. NO DOWNSPOUTS OR OUTSIDE DRAINS SHALL BE CONNECTED TO SANITARY SEWERS.
12. CLEAN-OUTS TO GRADE SHALL BE PROVIDED 18" MIN TO 30" MAXIMUM FROM BUILDING AND SPACED AT 100' (MAXIMUM) INTERVALS UNLESS APPROVED BY CITY.
13. ALL CONSTRUCTION OF SIDE SEWERS MUST COMPLY WITH CITY REGULATIONS.
14. TWO 45° BENDS WITH 24" MIN SEPARATION BETWEEN BENDS TO EQUAL 90° BEND.

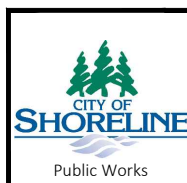

**MATERIALS LIST**

1. SDR-11 1-1/4" HDPE PIPE, DR11-55.
2. TRACER WIRE (16 GAUGE SOLID COPPER), NO. WI14BLK-500 OR EQUAL.
3. TRACER TAPE (MARKED SEWER) NO. WWTAPEDET-25.
4. 1-1/4" HDPE BUTT FUSED JOINT.
5. 6" MJ CAP TAPPED 1-1/4" OR 2" IP WITH MJ KIT NO. IFD2MX5L.
6. 2"x1-1/4" STAINLESS STEEL OR BRASS BUSHING.
7. IF PIPE IS 6" 3034 SEWER, A 6" MJ x PSM TRANSITION GASKET NO. IFGMPSMZ WILL BE REQUIRED.
8. 1-1/4" TRANSITION FITTING HDPE SDR11 x MIP 304SS (DRAS-5).
9. 2" BRASS SWING CHECK FIPxFIP (LEGEND VALVE T-451 OR EQUAL).

**SUPPLIER**

HD FOWLER CO.                      OR                      CORRECT EQUIPMENT

(THERE ARE OTHER SUPPLIERS THAT MAY CARRY THESE PARTS)

	PUBLICATION DATE: <b>3/1/2022</b>	REVISION DATE: <b>4/30/2021</b>
	STANDARD DETAIL NUMBER: <b>643</b>	SCALE: <b>NOT TO SCALE</b>
<b>GRINDER PUMP MATERIAL</b>		

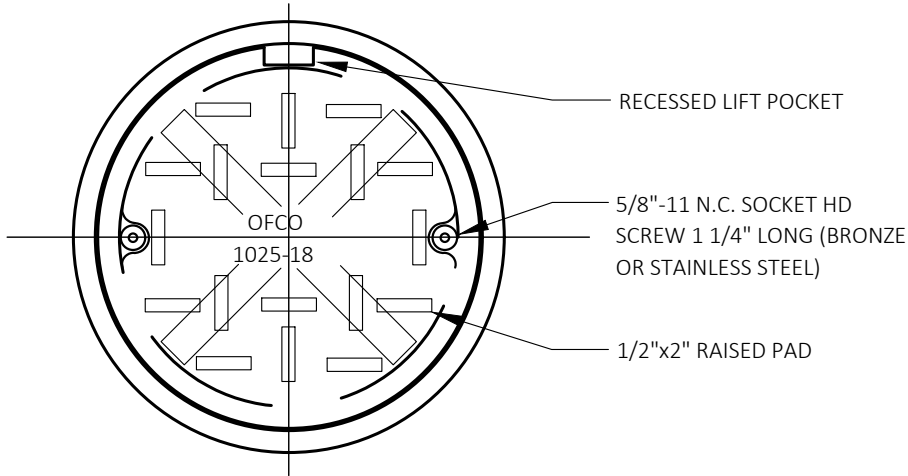

**PLAN**

NOTE:  
 IN SOFTSCAPE AND UNPAVED  
 USE CARSON MODEL 910-4  
 CLEANOUT COVER.

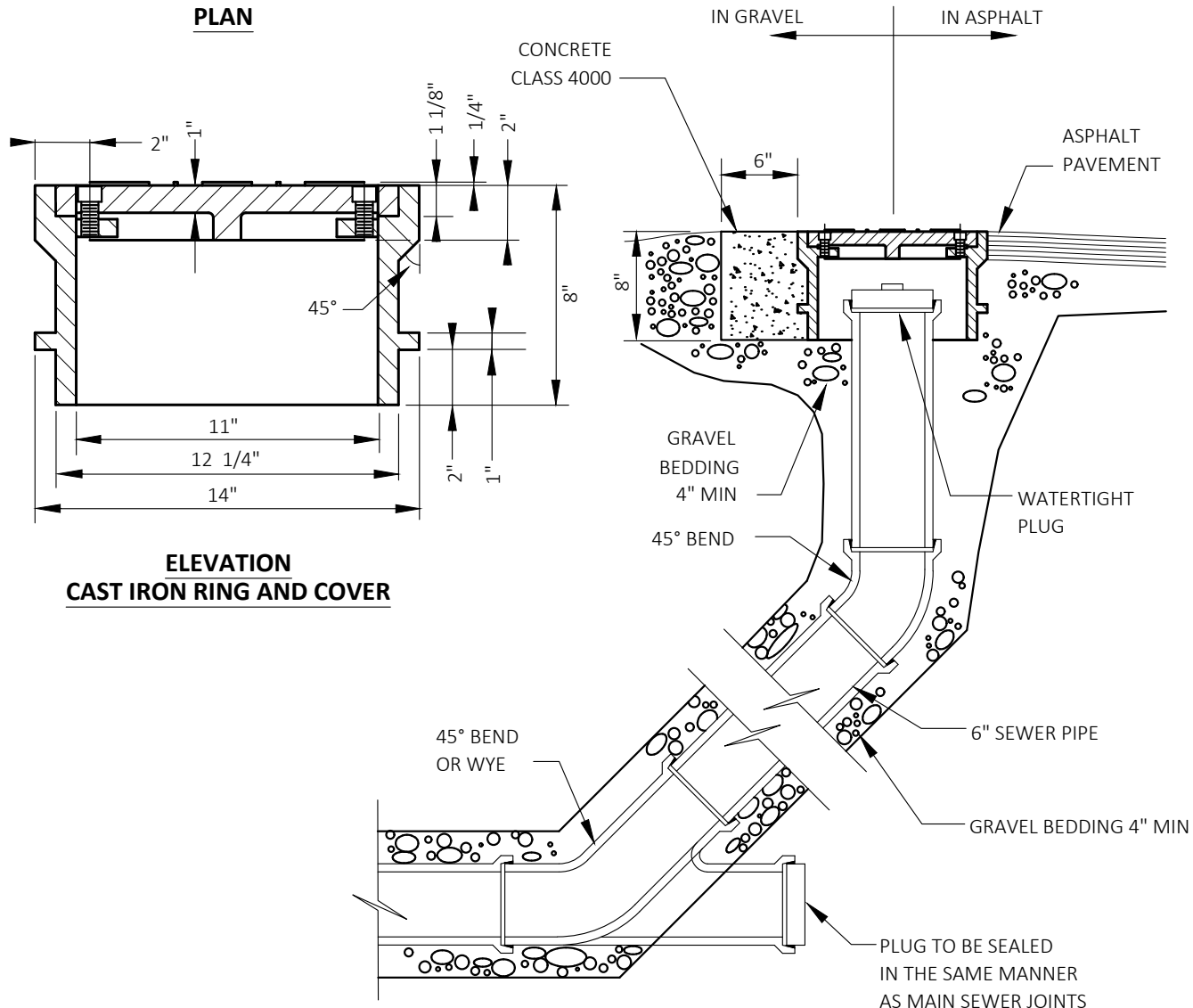

**ELEVATION  
 CAST IRON RING AND COVER**



PUBLICATION DATE: **3/1/2022** REVISION DATE: **4/30/2021**  
 STANDARD DETAIL NUMBER: **645** SCALE: **NOT TO SCALE**

**SANITARY SEWER CLEANOUT  
 DETAIL**

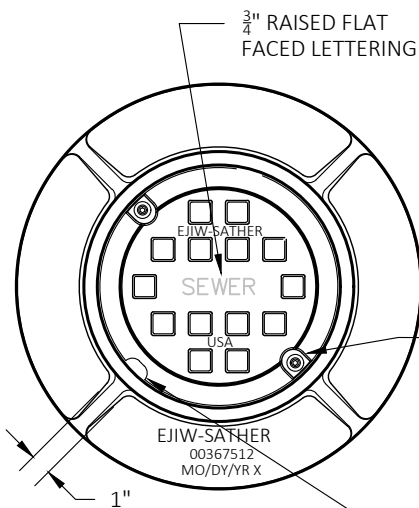

**PLAN**

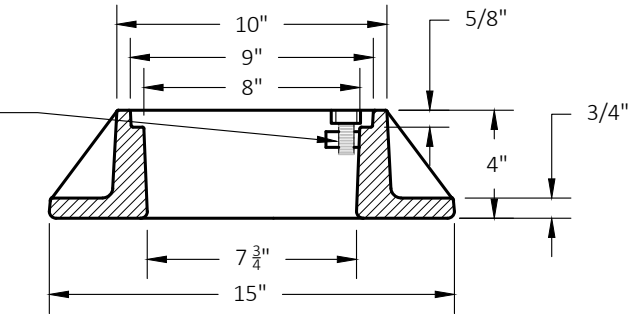
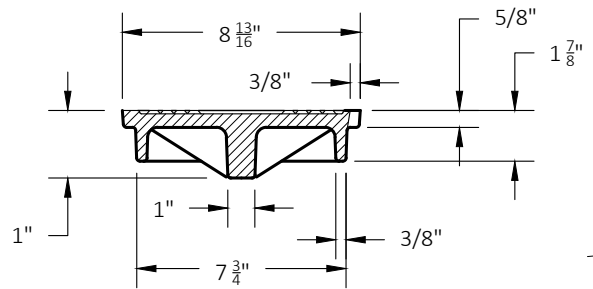

**ELEVATION CAST IRON RING AND COVER**

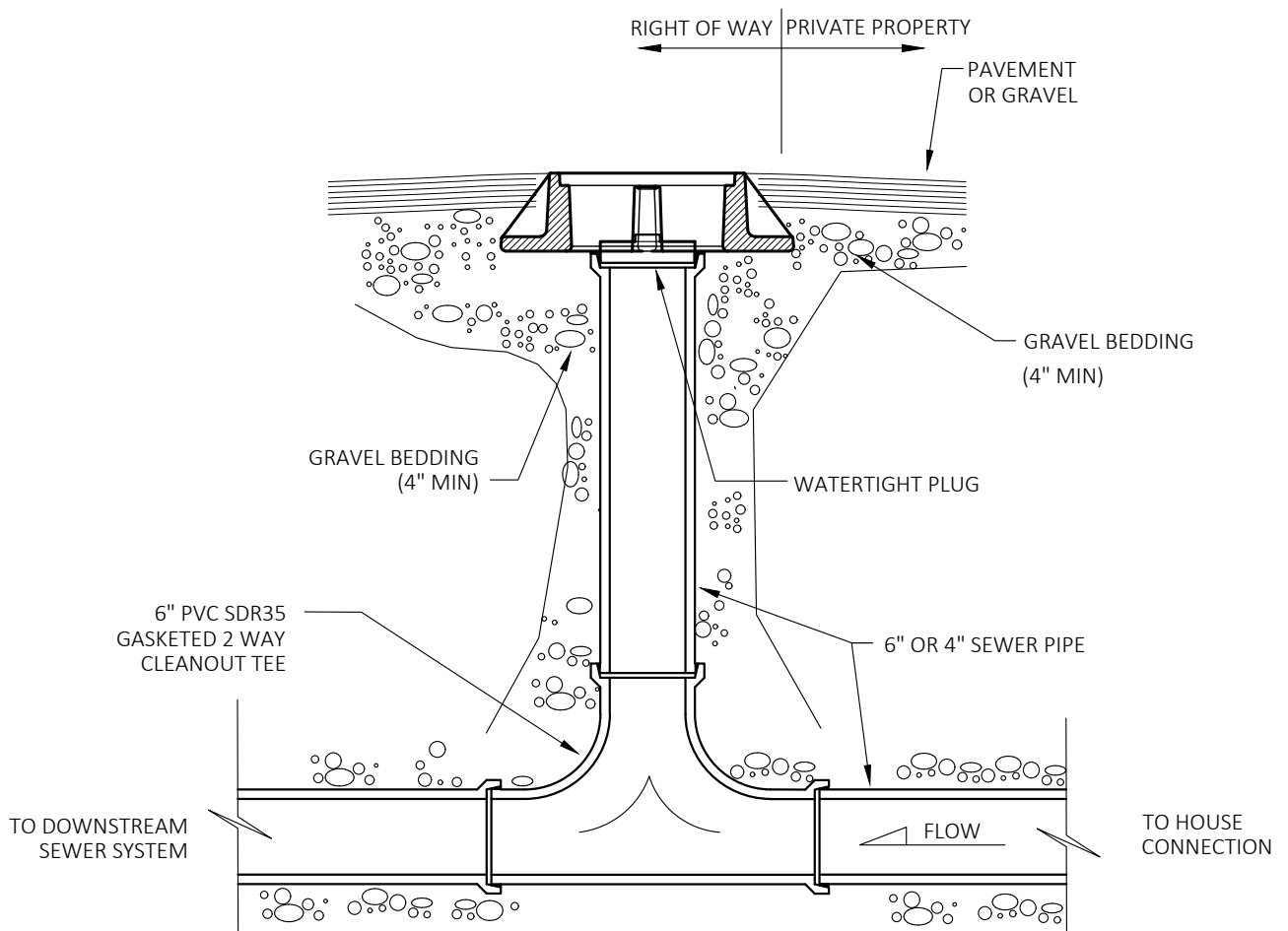

 CITY OF SHORELINE Public Works	PUBLICATION DATE: <b>3/1/2022</b>	REVISION DATE: <b>4/30/2021</b>
	STANDARD DETAIL NUMBER: <b>645A</b>	SCALE: <b>NOT TO SCALE</b>
	<b>TWO WAY SEWER CLEANOUT AT PROPERTY LINE</b>	

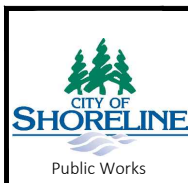
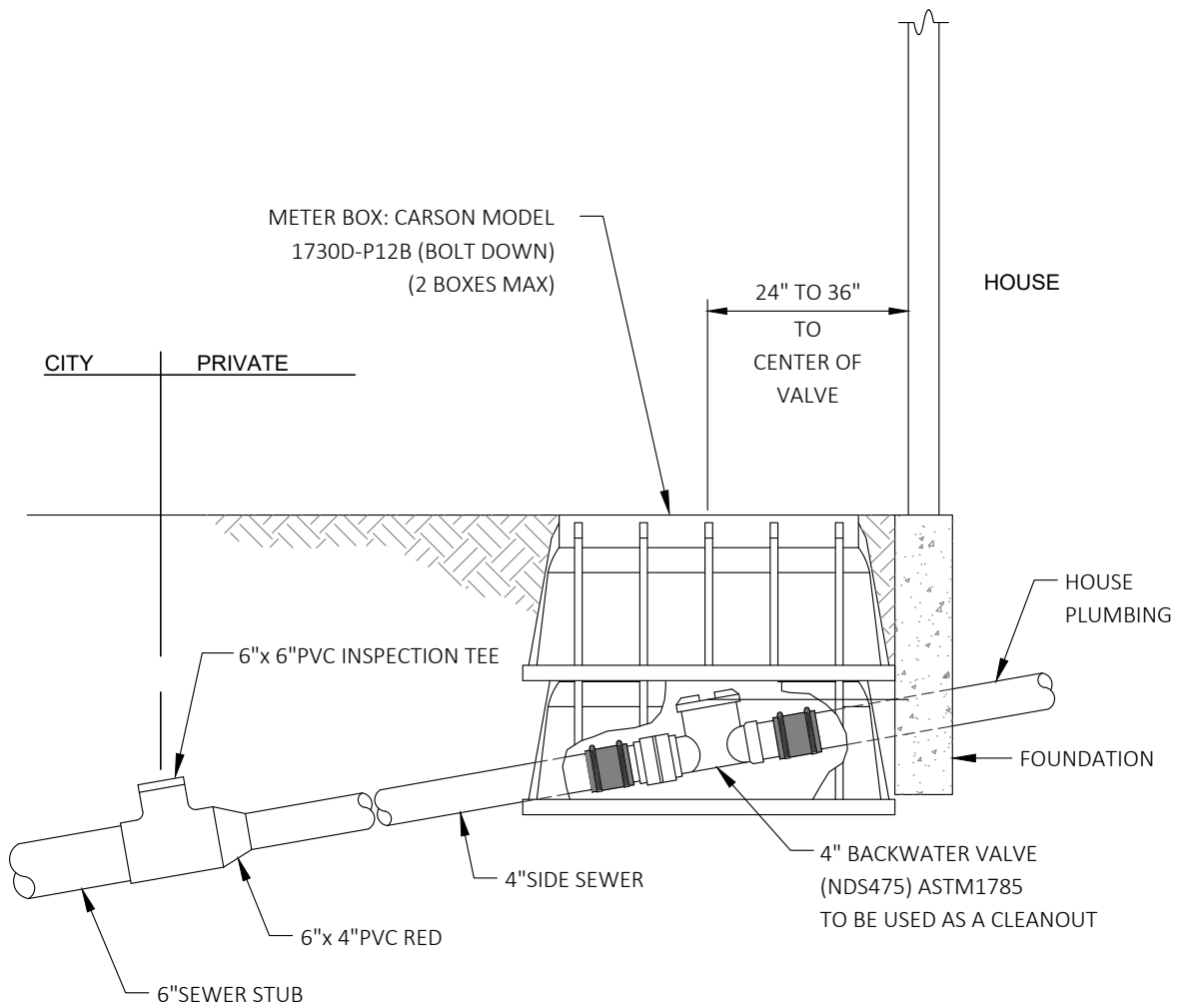
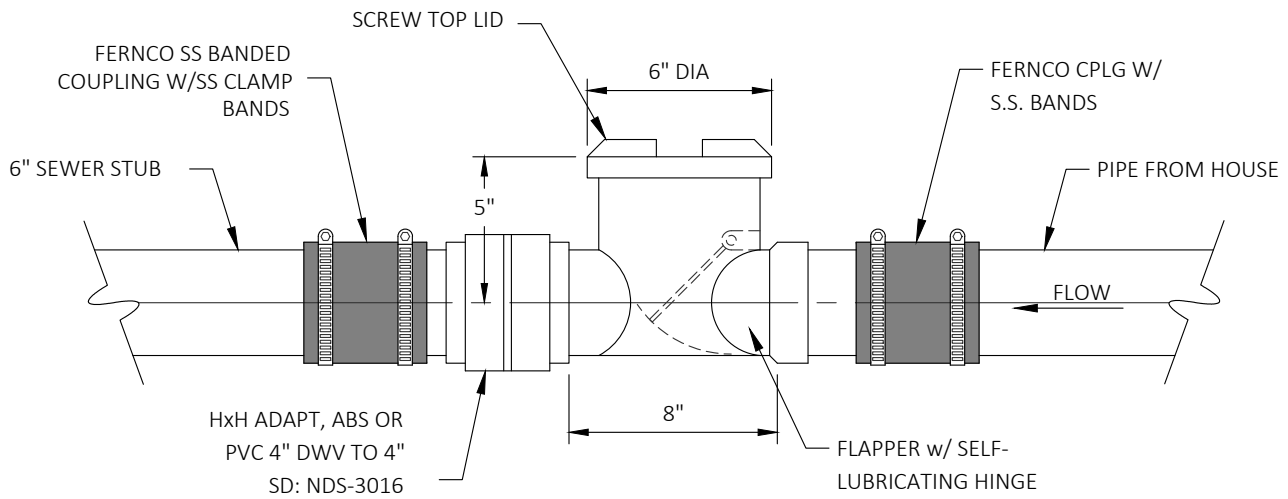

PUBLICATION DATE: **3/1/2022**

REVISION DATE: **4/30/2021**

STANDARD DETAIL NUMBER: **646**

SCALE: **NOT TO SCALE**

## BACKFLOW PREVENTER DETAIL - SANITARY



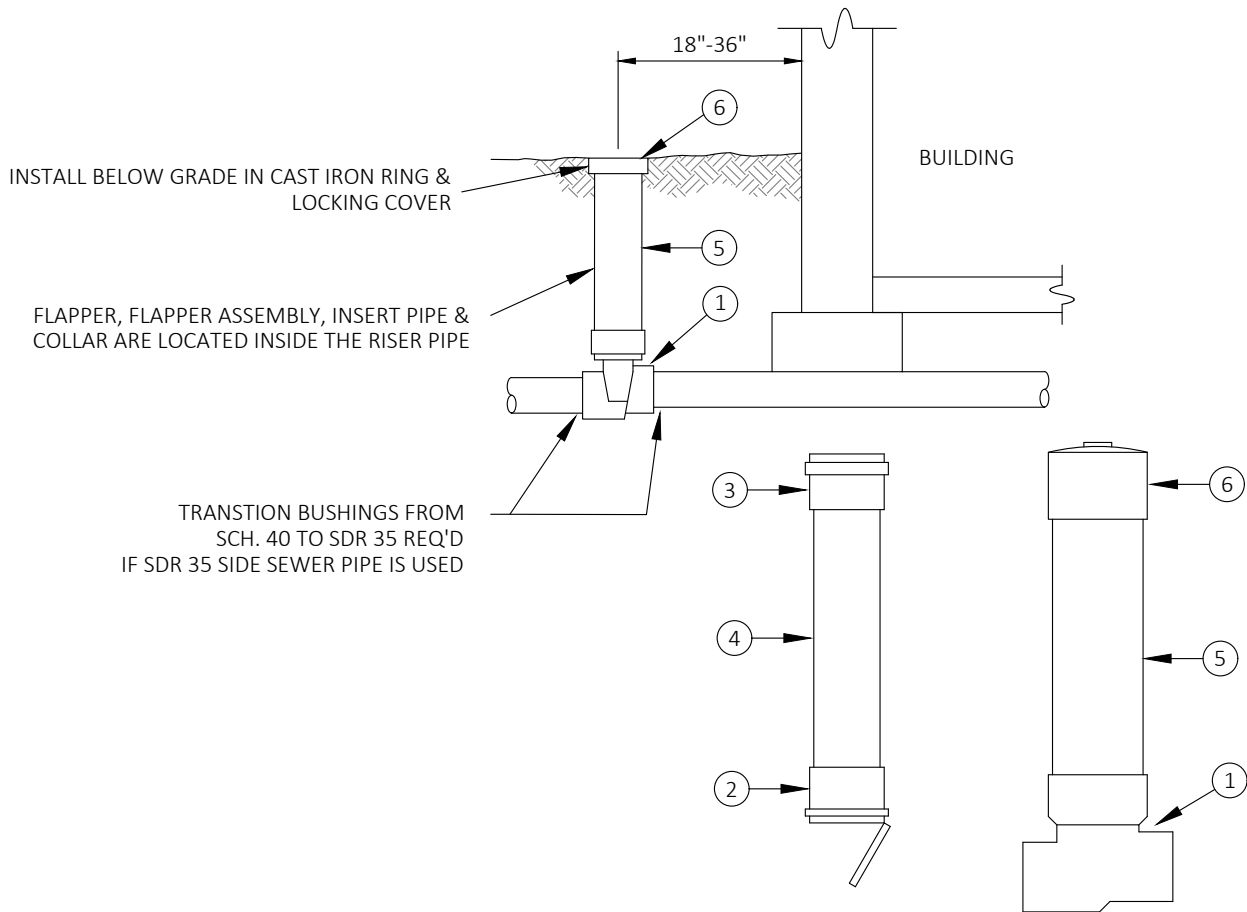

TRANSITION BUSHINGS FROM  
SCH. 40 TO SDR 35 REQ'D  
IF SDR 35 SIDE SEWER PIPE IS USED

**MATERIAL LIST:**

- ① CLEAN CHECK INC. 4" OR 6" SHOE VALVE BODY.  
USE 4" VALVE FOR SINGLE FAMILY RESIDENTIAL.  
USE 6" VALVE BODY FOR MULTI-FAMILY AND COMMERCIAL.
- ② FLAPPER AND FLAPPER ASSEMBLY BY CLEAN CHECK INC.
- ③ COLLAR BY CLEAN CHECK INC.
- ④ 4" OR 6" PVC INSERT PIPE. USE 4" INSERT PIPE FOR  
4" VALVE. USE 6" INSERT PIPE FOR 6" VALVE.  
CUT INSERT PIPE TO LENGTH PER SPECIFICATIONS.
- ⑤ 6" OR 8" PVC RISER PIPE. USE 6" RISER FOR 4"  
VALVE. USE 8" RISER FOR 6" VALVE. CUT TO LENGTH  
FOR BELOW GRADE INSTALLATION WITH CAST IRON  
RING AND LOCKING COVER OR TRAFFIC BEARING  
METER BOX.
- ⑥ 6" OR 8" THREAD BY HUB ADAPTER WITH THREADED  
PLUG. ADAPTER SHALL BE INSTALLED BELOW GRADE  
INSIDE A CAST IRON RING AND LOCKING COVER OR  
TRAFFIC BEARING METER BOX IN AREAS OF  
VEHICLE OR PEDESTRIAN TRAFFIC. SEE SURFACE  
CLEANOUT DETAIL FOR ADDITIONAL INFORMATION.

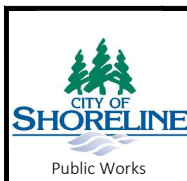

PUBLICATION DATE: <b>3/1/2022</b>	REVISION DATE: <b>4/30/2021</b>
STANDARD DETAIL NUMBER: <b>647</b>	SCALE: <b>NOT TO SCALE</b>

**BACKFLOW PREVENTER  
CLEANSWEEP DETAIL - SANITARY**

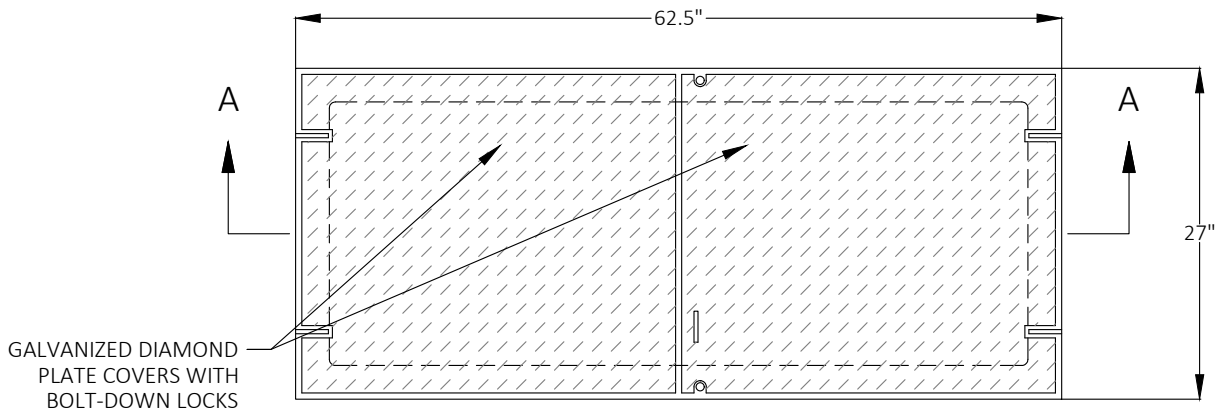

**COVER PLAN**

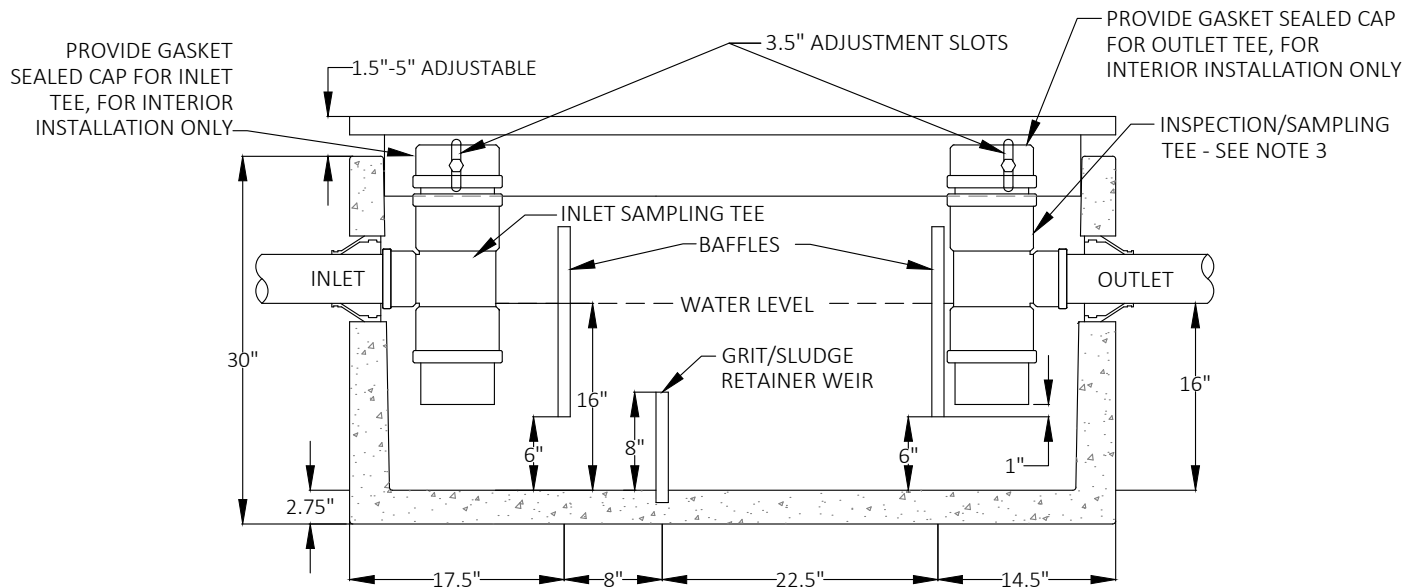

**SECTION A-A**

**NOTES:**

1. USE UTILITY VAULT COMPANY INC. MODEL #25-SA OR EQUAL. PRECAST VAULT SHALL HAVE KNOCKOUTS AT ALL PIPE OPENINGS. IF KNOCKOUTS ARE NOT PRESENT, THEN PIPE OPENINGS SHALL BE CORE-DRILLED. PIPE OPENINGS SHALL BE 2" LARGER THAN THE PIPE DIAMETER.
2. LOCATE VAULT WITHIN 20' OF DRIVE FOR ACCESS BY MAINTENANCE VEHICLES.
3. PVC INSPECTION AND SAMPLING TEE SHALL BE THE SAME SIZE AS THE OUTLET PIPE FOR 6" OUTLET OR GREATER. USE 6" BY OUTLET-SIZE TEE WHERE OUTLET PIPE SIZE IS LESS THAN 6". INSTALL GASKETED CAP ON TOP OF THE SAMPLING TEE, FOR INTERIOR INSTALLATION ONLY.
4. FILL WITH CLEAN WATER PRIOR TO START-UP OF THE SYSTEM.
5. BLACK WATER SHALL BE CARRIED BY SEPARATE SIDE SEWER AND NOT CONNECTED TO OIL/WATER SEPARATOR.
6. PIPE CONNECTION TO VAULT: KOR-N-SEAL OR EQUAL FOR CORE-DRILLED OPENINGS, OR SAND COLLAR FOR KNOCKOUT OPENING. SEAL ALL PIPE CONNECTIONS WITH NONSHRINK GROUT.
7. INTERIOR OIL/WATER SEPARATORS SHALL HAVE VENTING PER THE UNIFORM PLUMBING CODE.
8. PRIOR TO STARTUP, OIL/WATER SEPARATOR SHALL PASS 1% PER DAY LEAK TEST WHERE ONLY A MAXIMUM OF 1% OF OF DEAD STORAGE REDUCTION IS ALLOWED WITHIN A 24 HOUR PERIOD PER THE UNIFORM PLUMBING CODE.
9. ACCESS LID SHALL HAVE SLIP RESISTANT TREATMENT.



PUBLICATION DATE: <b>3/1/2022</b>	REVISION DATE: <b>4/30/2021</b>
STANDARD DETAIL NUMBER: <b>649</b>	SCALE: <b>NOT TO SCALE</b>

**SMALL OIL WATER SEPARATOR-SANITARY**

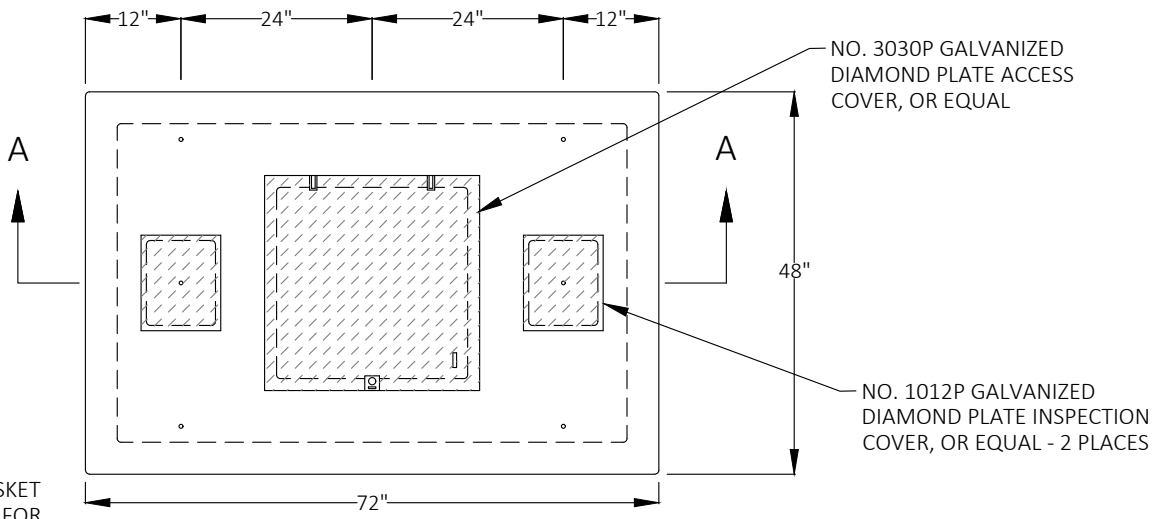

**COVER PLAN**

PROVIDE GASKET SEALED CAP FOR INLET TEE, FOR INTERIOR INSTALLATION ONLY

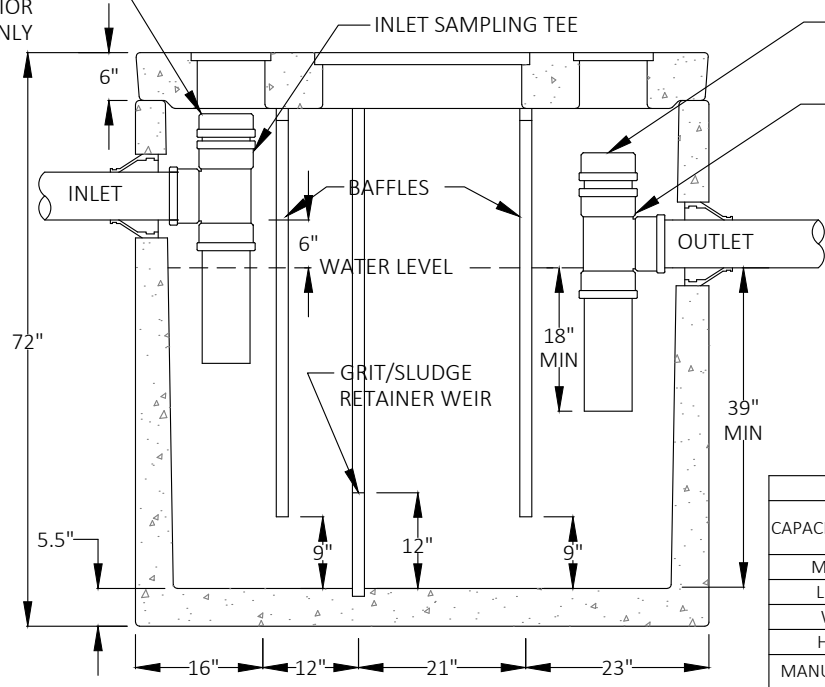

PROVIDE GASKET SEALED CAP FOR OUTLET TEE, FOR INTERIOR INSTALLATION ONLY

INSPECTION/SAMPLING TEE - SEE NOTE 3

VAULT CHART		
CAPACITY GALLONS	450	750-900
MODEL #	660-SA	577-SA
LENGTH	6'-0"	7'-0"
WIDTH	4'-0"	4'-8"
HEIGHT	6'-0"	7'-0"
MANUFACTURER	UV	UV

**SECTION A-A**

**NOTES:**

1. USE UTILITY VAULT COMPANY INC. MODELS (SEE CHART) OR EQUAL. PRECAST VAULT SHALL HAVE KNOCKOUTS AT ALL PIPE OPENINGS. IF KNOCKOUTS ARE NOT PRESENT, THEN PIPE OPENINGS SHALL BE CORE-DRILLED. PIPE OPENINGS SHALL BE 2" LARGER THAN THE PIPE DIAMETER.
2. LOCATE VAULT WITHIN 20' OF DRIVE FOR ACCESS BY MAINTENANCE VEHICLES.
3. P.V.C. INSPECTION AND SAMPLING TEE SHALL BE THE SAME SIZE AS THE OUTLET PIPE FOR 6" OUTLET OR GREATER. USE 6" P.V.C. TEE WHERE OUTLET PIPE SIZE IS LESS THAN 6". INSTALL GASKETED CAP ON TOP OF THE SAMPLING TEE, FOR INTERIOR INSTALLATIONS ONLY.
4. FILL WITH CLEAN WATER PRIOR TO START-UP OF THE SYSTEM.
5. BLACK WATER SHALL BE CARRIED BY SEPARATE SIDE SEWER AND NOT CONNECTED TO OIL/WATER SEPARATOR.
6. PIPE CONNECTION TO VAULT: KOR-N-SEAL OR EQUAL FOR CORE-DRILLED OPENINGS, OR SAND COLLAR FOR KNOCKOUT OPENING. SEAL ALL PIPE CONNECTIONS WITH NONSHRINK GROUT.
7. INTERIOR OIL/WATER SEPARATORS SHALL HAVE VENTING PER THE UNIFORM PLUMBING CODE.
8. PRIOR TO STARTUP, OIL/WATER SEPARATOR SHALL PASS 1% PER DAY LEAK TEST WHERE ONLY A MAXIMUM OF 1% OF DEAD STORAGE REDUCTION IS ALLOWED WITHIN A 24 HOUR PERIOD PER THE UNIFORM PLUMBING CODE.
9. ACCESS LIDS SHALL HAVE SLIP RESISTANT TREATMENT.



PUBLICATION DATE: <b>3/1/2022</b>	REVISION DATE: <b>4/30/2021</b>
STANDARD DETAIL NUMBER: <b>650</b>	SCALE: <b>NOT TO SCALE</b>
<b>MEDIUM OIL WATER SEPARATOR-SANITARY</b>	

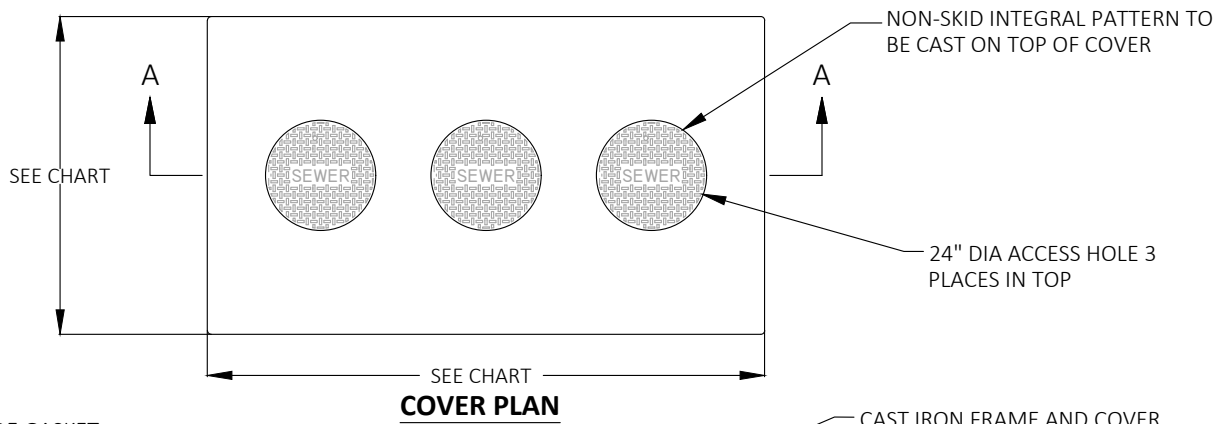

**COVER PLAN**

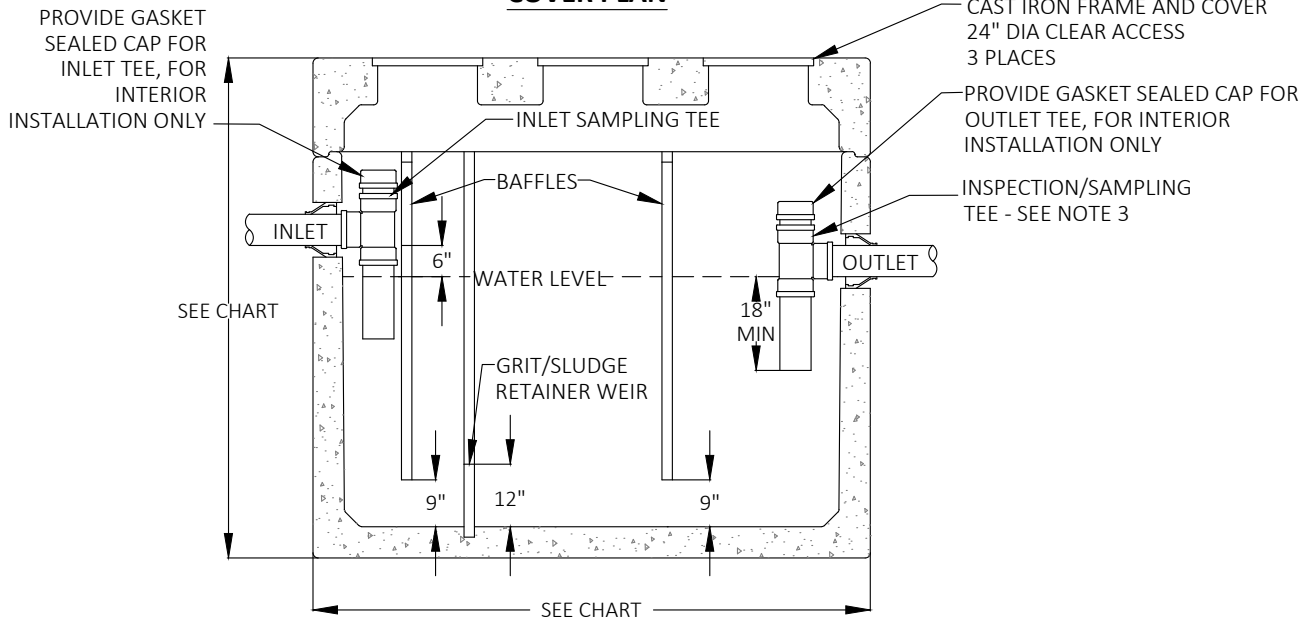

**SECTION A-A**

OIL/WATER SEPARATORS					
CAPACITY GALLONS	1100	1500	2200	3000- 4000	5000
MODEL #	4484-SA	5106-SA	612-SA	712-SA	814-SA
LENGTH	9'-0"	11'-2"	12'-8"	13'-1"	15'-7"
WIDTH	5'-0"	5'-8"	6'-8"	8'-0"	9'-7"
HEIGHT	7'-2½"	7'-2"	8'-0"	8'-7"	10'-½"
MANUFACTURER	UV	UV	UV	UV	UV

**NOTES:**

- USE UTILITY VAULT COMPANY INC. MODEL (SEE CHART) OR EQUAL. PRECAST VAULT SHALL HAVE KNOCKOUTS AT ALL PIPE OPENINGS. IF KNOCKOUTS ARE NOT PRESENT, THEN PIPE OPENINGS SHALL BE CORE-DRILLED. PIPE OPENINGS SHALL BE 2" LARGER THAN THE PIPE DIAMETER.
- LOCATE VAULT WITHIN 20' OF DRIVE FOR ACCESS BY MAINTENANCE VEHICLES.
- PVC SAMPLING TEE SHALL BE THE SAME SIZE AS THE OUTLET PIPE FOR 6" OUTLET OR GREATER. USE 6" P.V.C. TEE WHERE OUTLET PIPE SIZE IS LESS THAN 6". INSTALL GASKETED CAP ON TOP OF THE SAMPLING TEE, FOR INTERIOR INSTALLATION ONLY.
- FILL WITH CLEAN WATER PRIOR TO START-UP OF THE SYSTEM.
- BLACK WATER SHALL BE CARRIED BY SEPARATE SIDE SEWER AND NOT CONNECTED TO OIL/WATER SEPARATOR.
- PIPE CONNECTION TO VAULT: KOR-N-SEAL OR EQUAL FOR CORE-DRILLED OPENINGS, OR SAND COLLAR FOR KNOCKOUT OPENING. SEAL ALL PIPE CONNECTIONS WITH NONSHRINK GROUT.
- INTERIOR OIL/WATER SEPARATORS SHALL HAVE VENTING PER THE UNIFORM PLUMBING CODE.
- PRIOR TO STARTUP, OIL/WATER SEPARATOR SHALL PASS 1% PER DAY LEAK TEST WHERE ONLY A MAXIMUM OF 1% OF DEAD STORAGE REDUCTION IS ALLOWED WITHIN A 24 HOUR PERIOD PER THE UNIFORM PLUMBING CODE.

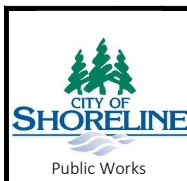

PUBLICATION DATE: **3/1/2022** REVISION DATE: **4/30/2021**

STANDARD DETAIL NUMBER: **651** SCALE: **NOT TO SCALE**

**LARGE OIL WATER SEPARATOR  
-SANITARY**

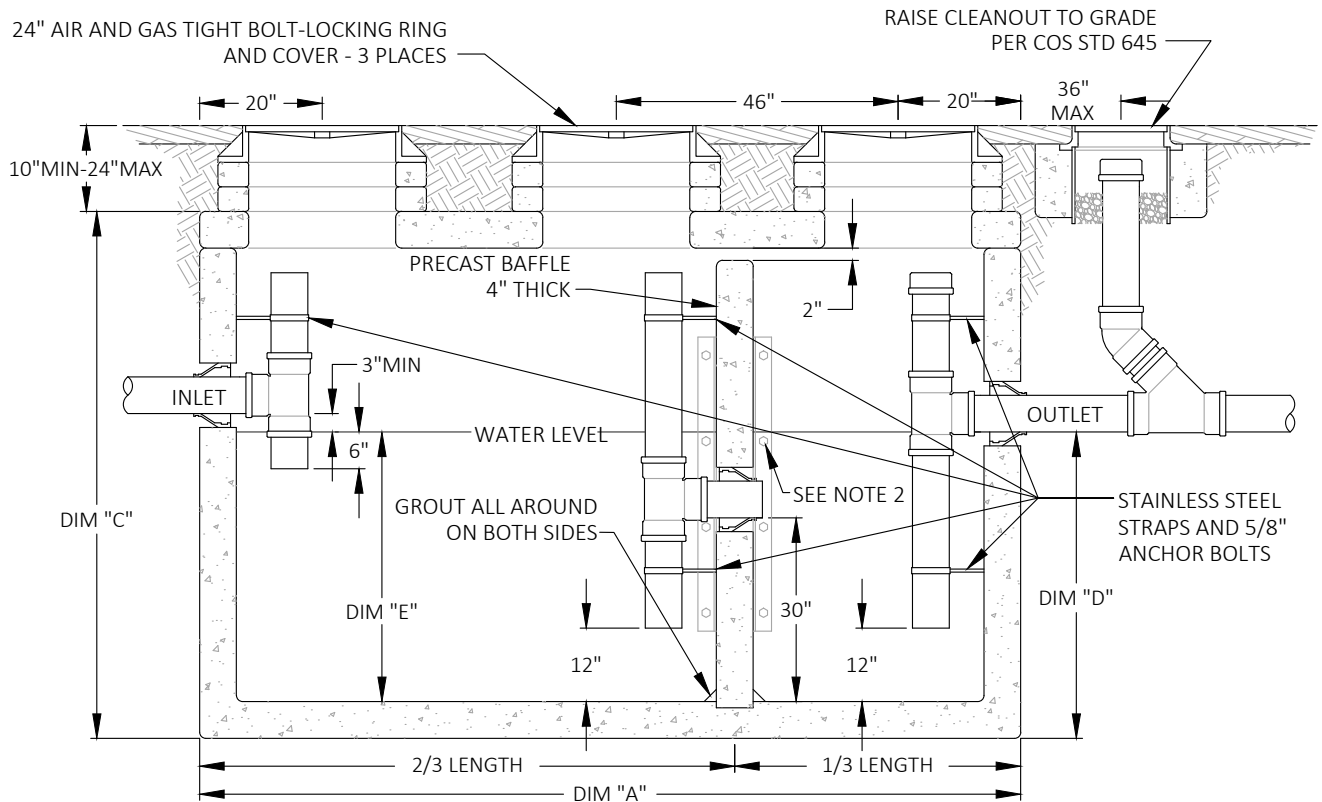

GALLON CAPACITY		600	750	1000	1500	2000	2500	3000	4000	5000	6000
UV CO. MODEL No.		577-GA	577-GA	4484-GA	5106-GA	612-GA	612-GA	712-GA	712-GA	818-GA	818-GA
LENGTH	DIM "A"	7'-0"	7'-0"	9'-0"	11'-2"	12'-8"	12'-8"	15'-7"	15'-7"	19'-11"	19'-11"
WIDTH	DIM "B"	4'-8"	4'-8"	5'-0"	5'-8"	6'-8"	6'-8"	9'-7"	9'-7"	9'-11"	9'-11"
HEIGHT	DIM "C"	7'-0"	7'-0"	7'-2"	7'-2"	8'-0"	8'-0"	8'-6 1/2"	8'-6 1/2"	8'-11"	10'-5"
	DIM "D"	3'-6"	4'-3"	4'-2"	4'-4"	4'-7"	5'-6"	5'-0"	6'-3"	6'-2"	7'-2"
WATER DEPTH	DIM "E"	3'-2"	3'-11"	3'-10"	4'-0"	3'-10"	4'-9"	3'-9"	5'-0"	4'-9"	5'-9"

**NOTES:**

- USE UTILITY VAULT COMPANY INC. PRECAST CONCRETE VAULT OR EQUAL. SEE CHART ABOVE FOR DIMENSIONS REQUIRED FOR EACH GALLON CAPACITY. PRECAST VAULT SHALL HAVE KNOCKOUTS AT ALL PIPE OPENINGS. IF KNOCKOUTS ARE NOT PRESENT, THEN PIPE OPENINGS SHALL BE CORE-DRILLED. PIPE OPENINGS SHALL BE 2" LARGER THAN THE PIPE DIAMETER.
- IF VAULT IS NOT SLOTTED TO ACCEPT PRECAST CONCRETE BAFFLE THEN BAFFLE SHALL BE HELD IN PLACE BY (2) 3"x3"x3/8" ANGLE 4FT LONG ON EACH SIDE. ALL 4 PIECES OF ANGLE SHALL BE HELD IN PLACE WITH 4 - 1/2" BOLTS WITH WASHERS SPACED 14" ON CENTER. ANGLE AND FASTENERS SHALL BE STAINLESS STEEL OR GALVANIZED AND ASPHALT COATED.
- LOCATE VAULT WITHIN 20' OF DRIVE FOR ACCESS BY MAINTENANCE VEHICLES.
- PVC INSPECTION AND SAMPLING TEE SHALL BE THE SAME SIZE AS THE OUTLET PIPE FOR 6" OUTLET OR GREATER. USE 6" PVC TEE WHERE OUTLET PIPE SIZE IS LESS THAN 6". INSTALL GASKETED CAP ON TOP OF THE SAMPLING TEE.
- POSITION RISERS BELOW ACCESS OPENINGS TO ALLOW CLEAR ACCESS TO RISER AND VAULT CHAMBER.
- ALL RINGS AND COVERS SHALL BE AIR AND GAS TIGHT BOLT-LOCKING TYPE, RATED FOR H2O LOAD MIN.
- FOR 1000 GALLON INTERCEPTOR, SUBSTITUTE 12" RING AND COVER FOR "CENTER MANHOLE". LOCATE 12" RING AND COVER DIRECTLY ABOVE TEE AND RISER.
- FOR 600 AND 700 GALLON INTERCEPTOR, SUBSTITUTE 30" RING AND COVER FOR THE TWO 24" MANHOLES LOCATED AT THE OUTLET END OF THE VAULT. CENTER OF 30" RING AND COVER SHALL BE LOCATED 2 FT FROM THE OUTLET FACE OF VAULT.
- FILL WITH CLEAN WATER PRIOR TO START-UP OF THE SYSTEM.
- GRAY WATER ONLY. BLACK WATER SHALL BE CARRIED BY SEPARATE SIDE SEWER.
- PIPE CONNECTION TO VAULT: KOR-N-SEAL OR EQUAL FOR CORE-DRILLED OPENINGS, OR SAND COLLAR FOR KNOCKOUT OPENING. SEAL ALL PIPE CONNECTIONS WITH NONSHRINK GROUT.
- INTERIOR GREASE INTERCEPTORS SHALL HAVE VENTING PER THE UNIFORM PLUMBING CODE.
- PRIOR TO STARTUP, GREASE INTERCEPTOR SHALL PASS 1% PER DAY LEAK TEST WHERE ONLY A MAXIMUM OF 1% OF DEAD STORAGE REDUCTION IS ALLOWED WITHIN A 24 HOUR PERIOD PER THE UNIFORM PLUMBING CODE.

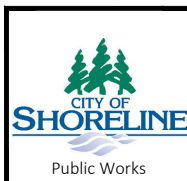

PUBLICATION DATE: <b>3/1/2022</b>	REVISION DATE: <b>4/30/2021</b>
STANDARD DETAIL NUMBER: <b>652</b>	SCALE: <b>NOT TO SCALE</b>
<b>GREASE INTERCEPTOR DETAIL-SANITARY</b>	

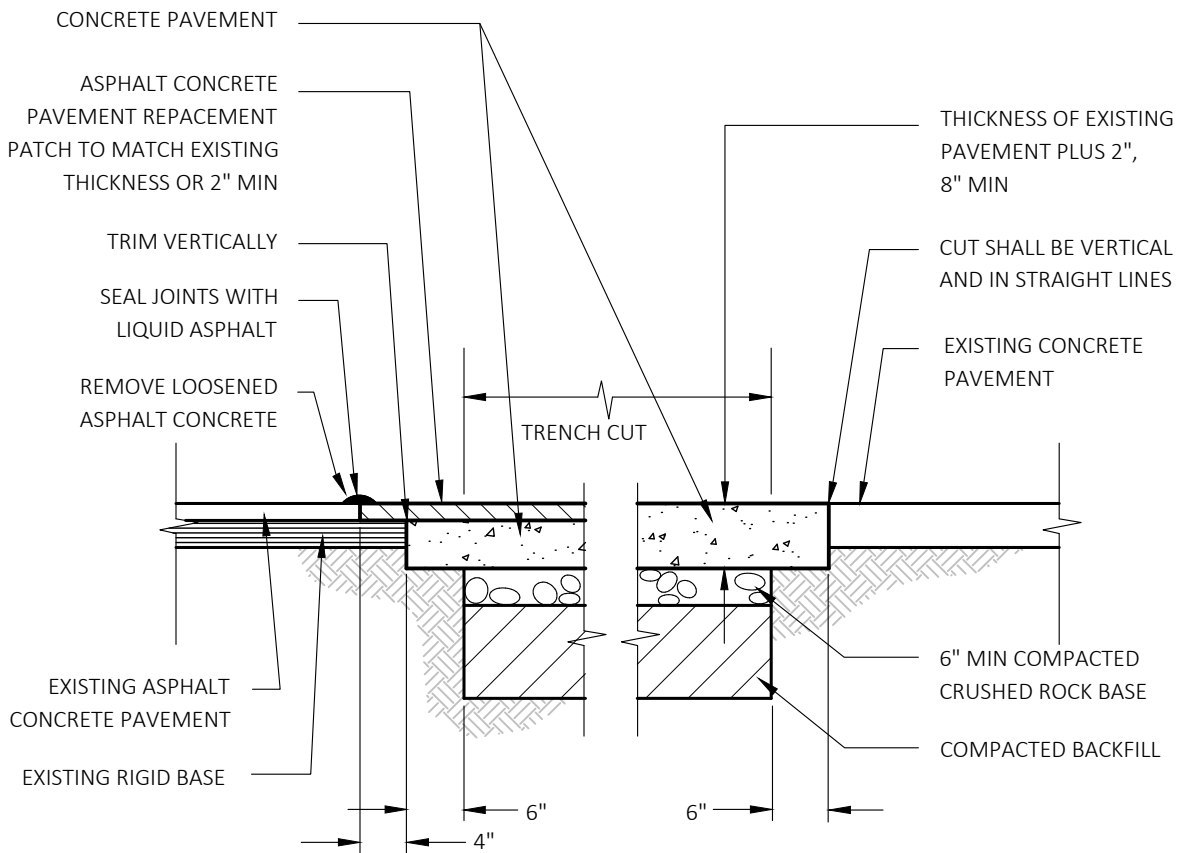

**RIGID PAVEMENT WITH ASPHALTIC CONCRETE SURFACE**

**CEMENT CONCRETE PAVEMENT**

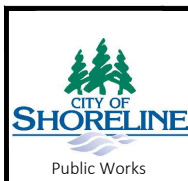

PUBLICATION DATE: <b>3/1/2022</b>	REVISION DATE: <b>4/30/2021</b>
STANDARD DETAIL NUMBER: <b>653</b>	SCALE: <b>NOT TO SCALE</b>

**RIGID PAVEMENT PATCHING**