

**NOTES:**

1. SEE WSDOT 9-03.12[4].
2. IF ROCKERY OR RETAINING WALL IS BEHIND ROLLED CURB, FACE OF ROCKERY OR RETAINING WALL MUST BE A MIN. OF 10' FROM TRAVELED WAY.
3. A PEDESTRIAN RAIL, PER COS STD 324, IS REQUIRED WHEN ROCKERY HEIGHT IS 3' OR GREATER. THE USAGE OF A CHAIN LINK FENCE MAY BE APPROVED.
4. ALL ROCKERIES OVER 4' IN HEIGHT ON PUBLIC OR PRIVATE PROPERTY SHALL REQUIRE STRUCTURAL REVIEW.
5. SEE WSDOT 9-03.12(2).

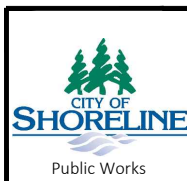

PUBLICATION DATE: <b>3/1/2022</b>	REVISION DATE: <b>10/6/2021</b>
STANDARD DETAIL NUMBER: <b>501</b>	SCALE: <b>NOT TO SCALE</b>

**ROCK FACING - CUT SECTION**

\*AS NECESSARY TO MEET TERRAIN AND SIGHT DISTANCE REQUIREMENTS

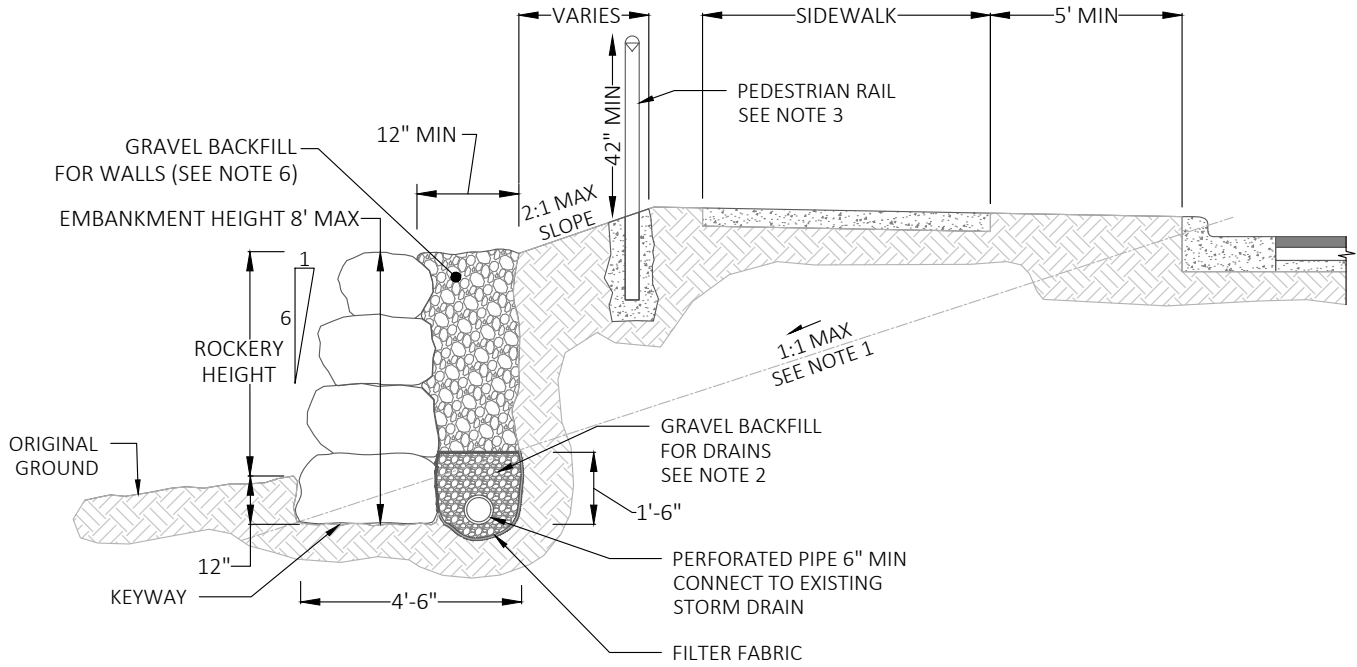

**NOTES:**

1. FLATTER SLOPE MAY BE REQUIRED IN LESS STABLE SOIL.
2. SEE WSDOT 9-03.12[4].
3. A PEDESTRIAN RAIL, PER STND DWG 324, IS REQUIRED WHEN ROCKERY HEIGHT IS 3' OR GREATER. THE USAGE OF A CHAIN LINK FENCE MAY BE APPROVED.
4. TRAFFIC BARRIERS MAY BE REQUIRED ON ROADS WITH SPEED LIMITS OF 30 MPH OR GREATER, WHERE ROCKERY HEIGHTS EXCEED 6'. SEE CHAPTER 7 OF THE WSDOT DESIGN MANUAL.
5. ALL ROCKERIES OVER 4' IN HEIGHT ON PUBLIC OR PRIVATE PROPERTY SHALL REQUIRE STRUCTURAL REVIEW.
6. SEE WSDOT 9-03.12(2).

	PUBLICATION DATE: <b>3/1/2022</b>	REVISION DATE: <b>2/10/2021</b>
	STANDARD DETAIL NUMBER: <b>502</b>	SCALE: <b>NOT TO SCALE</b>
<b>ROCK FACING - FILL SECTION</b>		

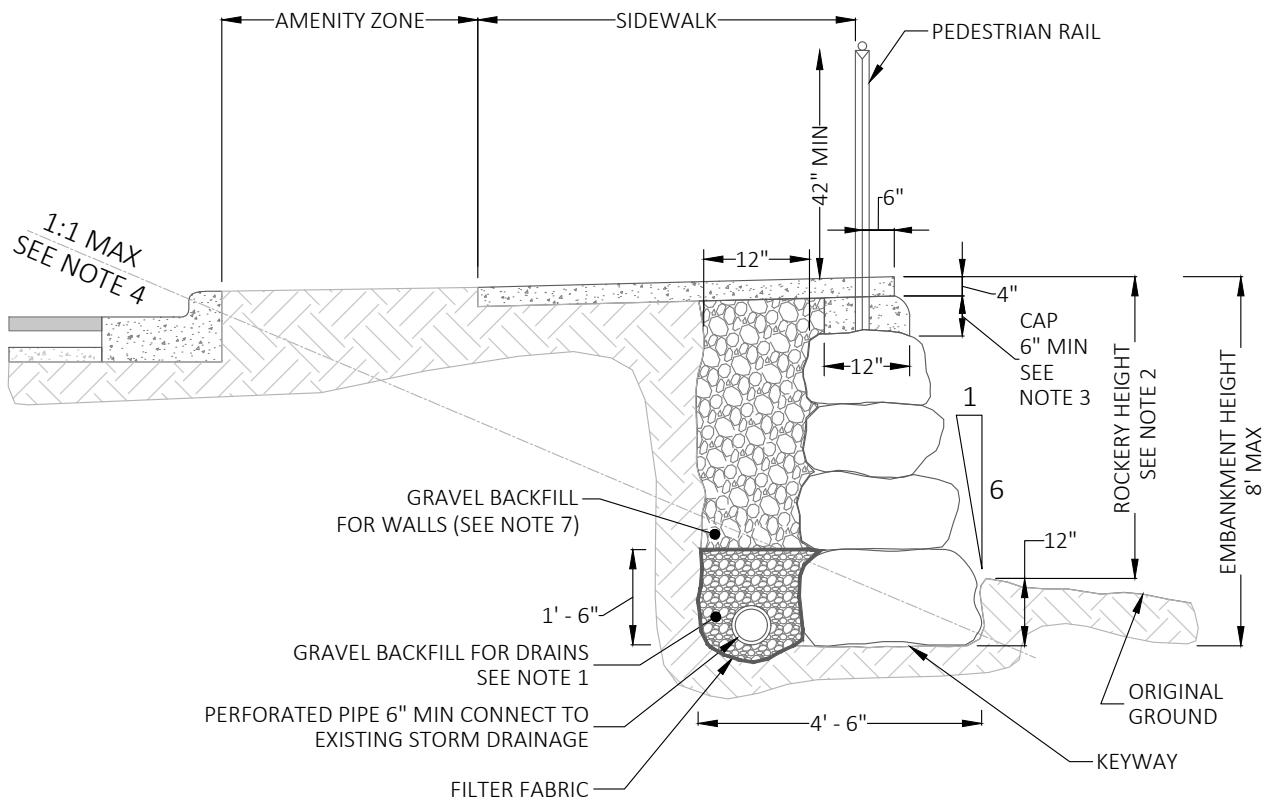

**NOTES:**

1. WSDOT 9-03.12[4].
2. A PEDESTRIAN RAIL, PER STND DWG 324, IS REQUIRED WHEN ROCKERY HEIGHT IS 3' OR GREATER. THE USAGE OF A CHAIN LINK FENCE MAY BE APPROVED.
3. CAP SHALL BE CONCRETE CLASS 4000.
4. FLATTER SLOPE MAY BE REQUIRED IN LESS STABLE SOILS.
5. TRAFFIC BARRIERS MAY BE REQUIRED ON ROADS WITH SPEED LIMITS OF 30 MPH OR GREATER, WHERE HEIGHTS EXCEED 6'. SEE CHAPTER 7 OF THE WSDOT DESIGN MANUAL.
6. ALL ROCKERIES OVER 4' IN HEIGHT ON PUBLIC OR PRIVATE PROPERTY SHALL REQUIRE STRUCTURAL REVIEW.
7. SEE WSDOT 9-03.12(2).

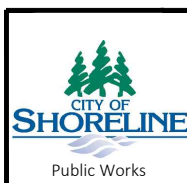

PUBLICATION DATE: <b>3/1/2022</b>	REVISION DATE: <b>2/10/2021</b>
STANDARD DETAIL NUMBER: <b>503</b>	SCALE: <b>NOT TO SCALE</b>

**ROCK FACING UNDER SIDEWALK**

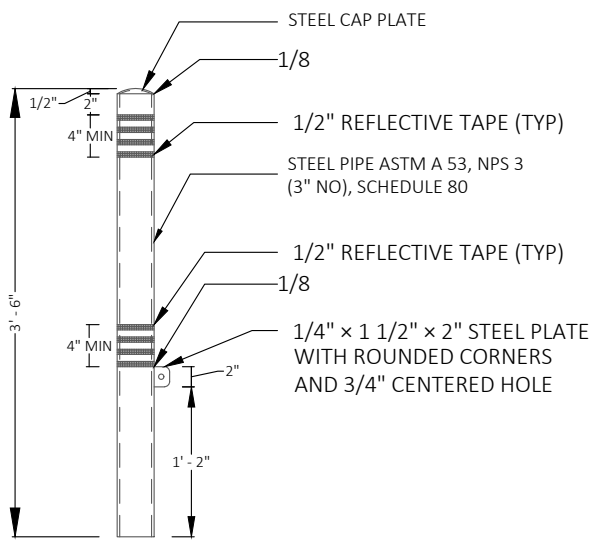

**POST**

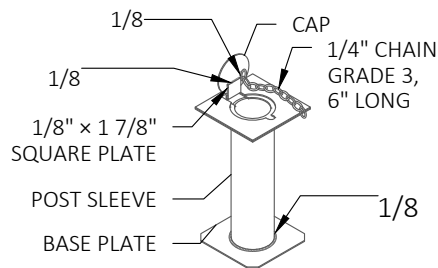

**BASE ASSEMBLY**

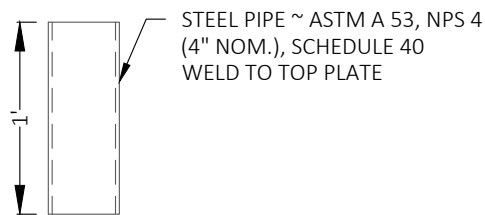

**POST SLEEVE**

**NOTE:**  
THIS BOLLARD DOES NOT HAVE AN EFFECTIVE BREAKAWAY DESIGN FEATURE AND CANNOT BE INSTALLED WITHIN THE DESIGN CLEAR ZONE.

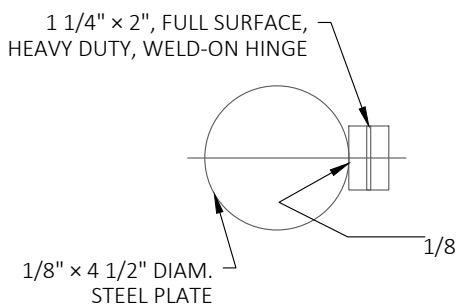

**CAP AND HINGE**

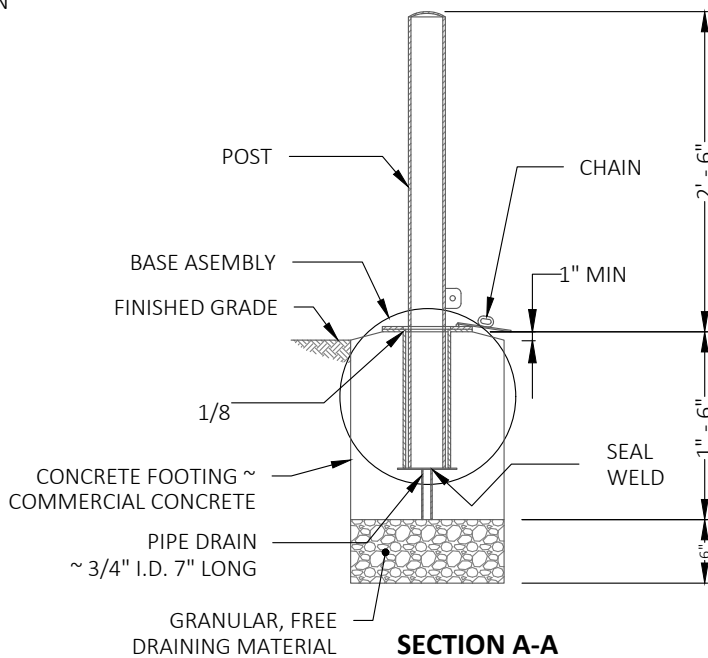

**SECTION A-A**

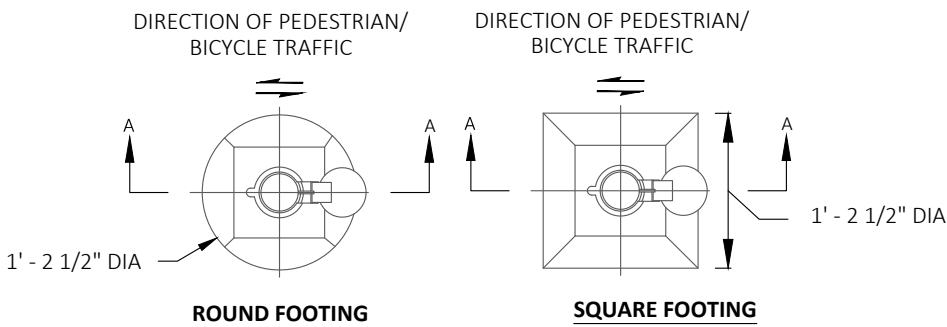

**ROUND FOOTING**

**SQUARE FOOTING**

**PLAN VIEW**

	PUBLICATION DATE: <b>3/1/2022</b>	REVISION DATE: <b>2/11/2020</b>
	STANDARD DETAIL NUMBER: <b>505</b>	SCALE: <b>NOT TO SCALE</b>
<b>BOLLARDS</b>		

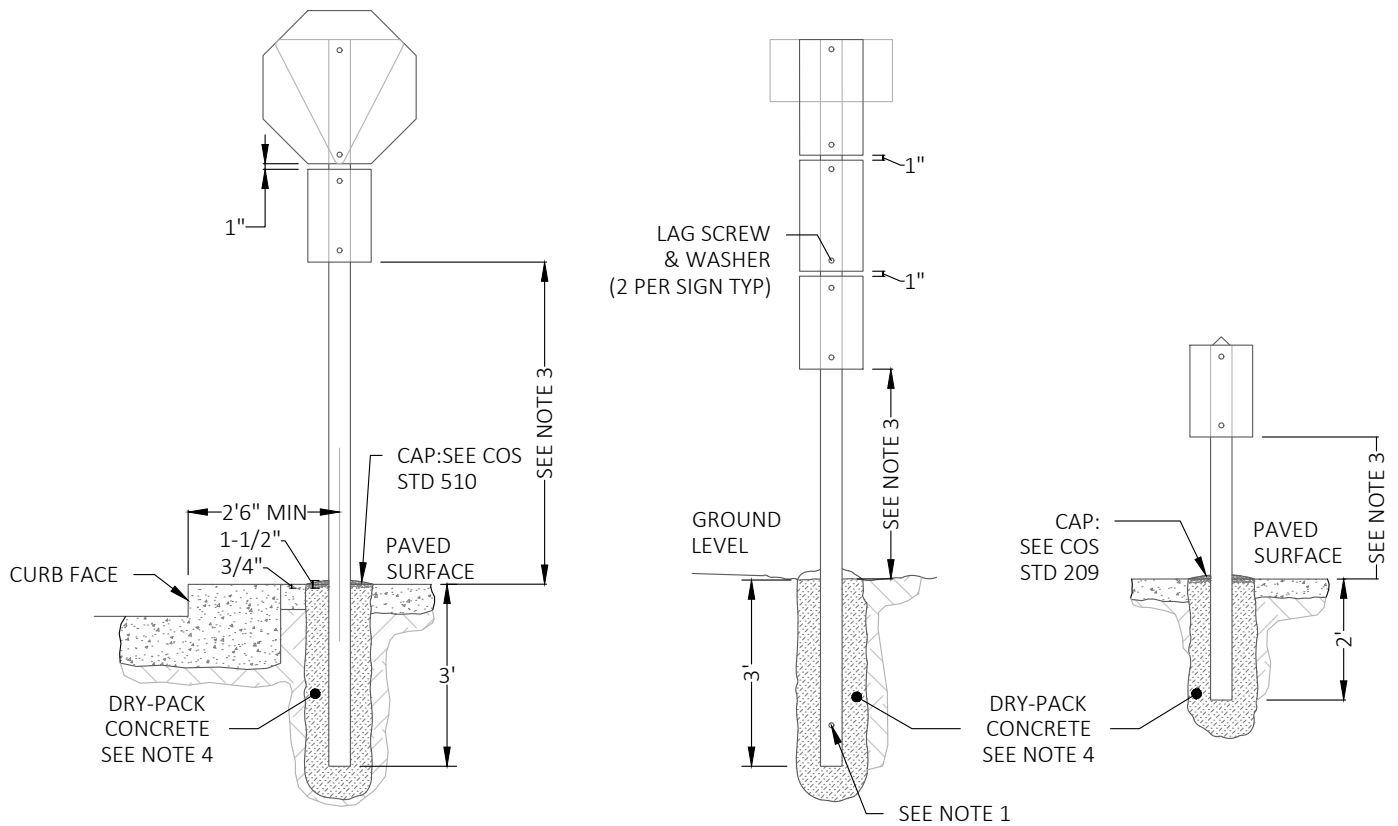

**NOTES:**

1. CONTACT SHORELINE PUBLIC WORKS (206-801-2400) FOR DETAILS REGARDING SIGN MESSAGE AND FOUNDATION.
2. THE USE OF WOOD POST REQUIRES APPROVAL FROM THE ENGINEER.
3. MIN 7' IF THERE IS PEDESTRIAN OR PARKING MOVEMENTS.
4. DRY-PACK CONCRETE: MUST BE BAGGED PREMIX CONCRETE CONTAINING WELL GRADED AGGREGATE, SAND, AND CEMENT, MIXED WITH APPROXIMATELY 1 QUART OF WATER PER 60 POUND BAG, OR ANY CONCRETE APPROVED BY THE ENGINEER.

	PUBLICATION DATE: <b>3/1/2022</b>	REVISION DATE: <b>2/10/2021</b>
	STANDARD DETAIL NUMBER: <b>507</b>	SCALE: <b>NOT TO SCALE</b>
<h2>TRAFFIC SIGN &amp; WOOD POST INSTALLATION</h2>		

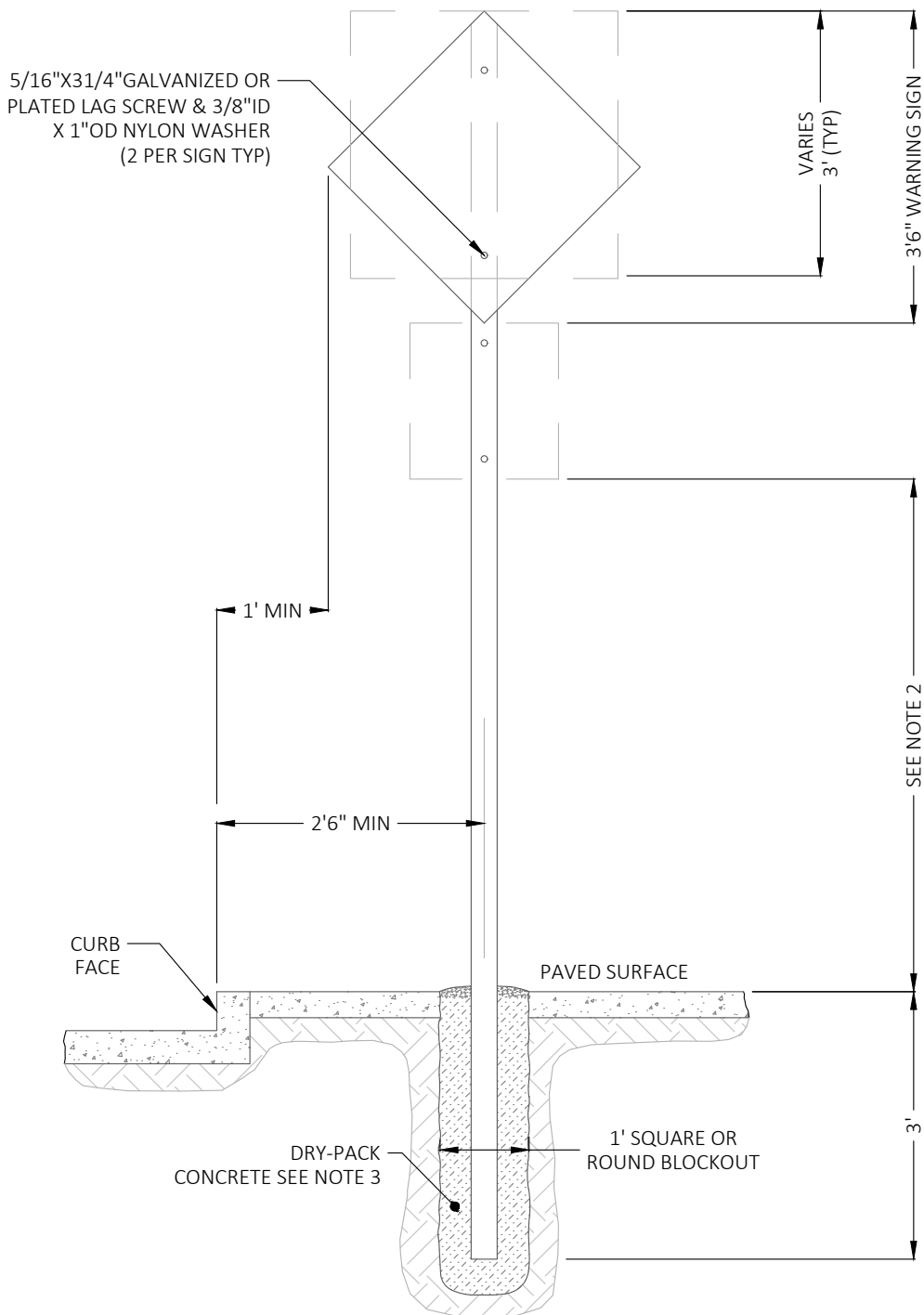

**NOTES:**

1. SIGN SHALL BE ATTACHED WITH TOP EDGE OF SIGN FLUSH WITH TOP OF SQUARE SECTION OF POST.
2. MIN 7' IF THERE IS PEDESTRIAN OR PARKING MOVEMENTS.
3. DRY-PACK CONCRETE: MUST BE BAGGED PREMIX CONCRETE CONTAINING WELL GRADED AGGREGATE, SAND, AND CEMENT, MIXED WITH APPROXIMATELY 1 QUART OF WATER PER 60 POUND BAG, OR ANY CONCRETE APPROVED BY THE ENGINEER.

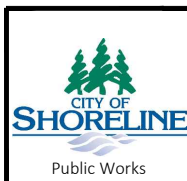

PUBLICATION DATE: **3/1/2022**

REVISION DATE: **2/10/2021**

STANDARD DETAIL NUMBER: **508**

SCALE: **NOT TO SCALE**

**TRAFFIC SIGN & METAL POST  
INSTALLATION**

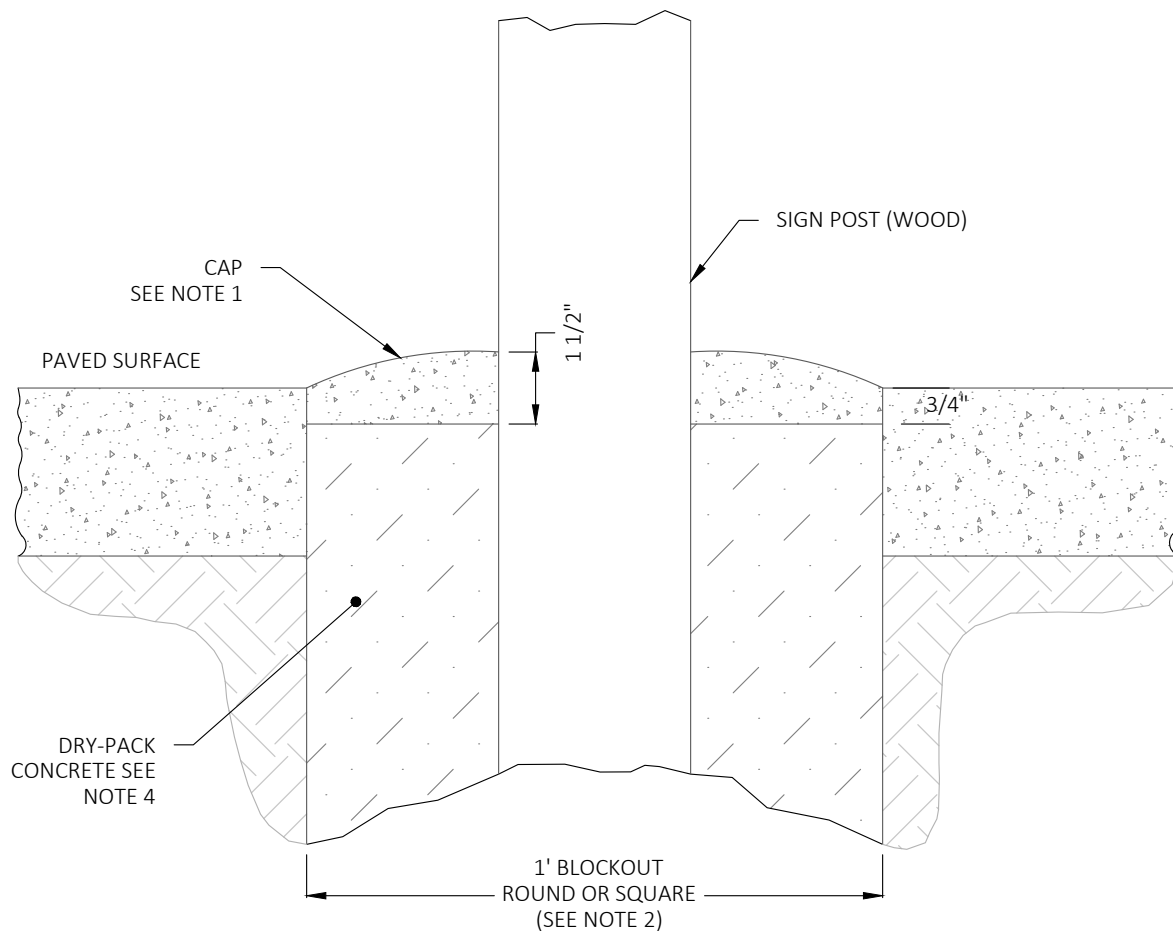

**NOTES:**

1. CAP SHALL BE MADE OF THE SAME MATERIAL AS THE SURROUNDING PAVED SURFACE AND SHALL BE MOUNDED FOR DRAINAGE AWAY FROM POST.
2. BLOCKOUTS SHALL BE PROVIDED FOR POST LOCATIONS WHERE NEW CONCRETE PAVEMENT (SIDEWALK, ROADWAY, ETC) IS BEING INSTALLED.
3. WHERE POST IS BEING INSTALLED IN EXISTING PAVED AREAS, HOLE IN PAVED SURFACE SHALL NOT EXCEED 1'-0" NOMINAL DIAMETER.
4. DRY-PACK CONCRETE: MUST BE BAGGED PREMIX CONCRETE CONTAINING WELL GRADED AGGREGATE, SAND, AND CEMENT, MIXED WITH APPROXIMATELY 1 QUART OF WATER PER 60 POUND BAG, OR ANY CONCRETE APPROVED BY THE ENGINEER.

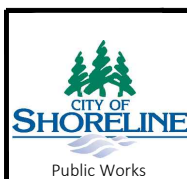

PUBLICATION DATE: <b>3/1/2022</b>	REVISION DATE: <b>2/10/2021</b>
STANDARD DETAIL NUMBER: <b>509</b>	SCALE: <b>NOT TO SCALE</b>

**POST CAP**

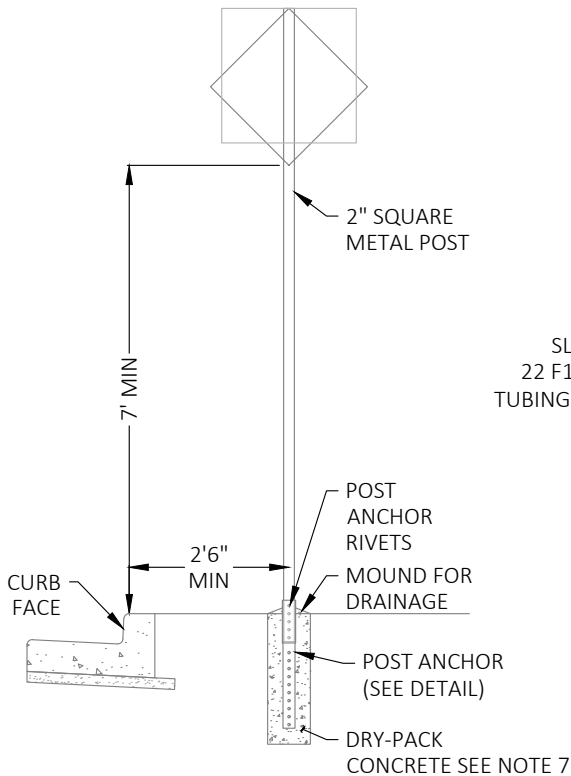

**DIRECT BURIAL INSTALLATION**

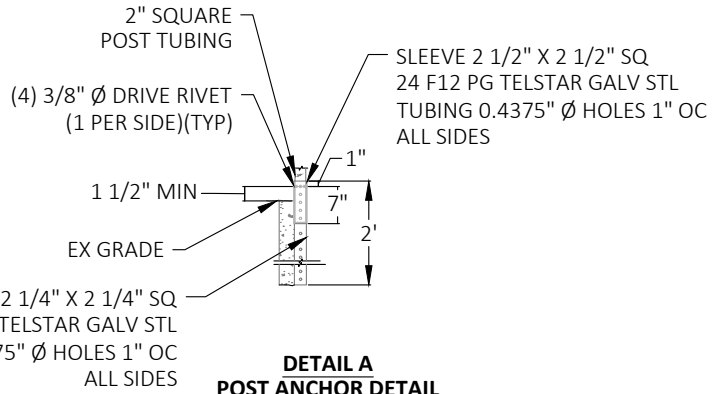

**DETAIL A  
POST ANCHOR DETAIL**

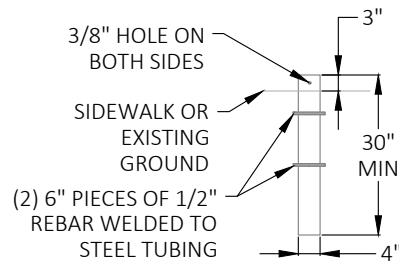

**DETAIL B  
ANCHOR DETAIL**

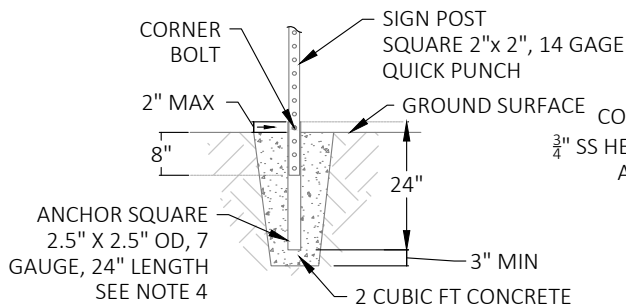

**DETAIL C  
SQUARE METAL POST**

CORNER BOLT SHALL BE  
3/4\"/>

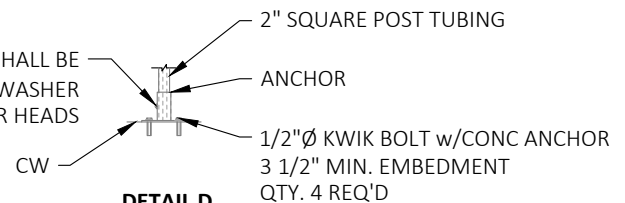

**DETAIL D  
SURFACE MOUNT INSTALLATION**

**NOTES:**

1. POST ANCHOR RIVETS SHALL BE 1 1/2" ABOVE GROUND LEVEL.
2. FOR POST RELOCATIONS, OLD CONCRETE SHALL BE REMOVED FROM POST.
3. WHERE SURFACE MOUNTED 2" SQUARE METAL POSTS ARE REQUIRED ON SLOPED SIDEWALK, THE CONTRACTOR SHALL PLUMB THE POST BY BUILDING A NON-SHRINK GROUT PAD UNDER PEDESTAL ASSEMBLY WITH SMOOTH 1H TO 1V TAPER ON THE GROUT EDGE. THE BOLT ANCHOR LENGTH SHALL BE ADJUSTED TO PROVIDE A MIN 3 1/2 INCH EMBEDMENT THROUGH THE GROUT INTO THE EXISTING CONCRETE.
4. POST SHALL BE ROLLED CARBON SHEET STEEL, ASTM A570 GRADE 50 AND BE HOT DIPPED GALVANIZED AASHTO M-120 YIELD STRENGTH 60,000 PSI MIN. POST SHALL HAVE 7/16" DIE-PUNCHED KNOCKOUTS ON 1" CENTERS FULL LENGTH ON ALL FOUR SIDES.
5. ANCHOR SHALL HAVE 4 7/16" HOLES ONE EACH SIDE 2" FROM TOP END. FINISH SHALL BE ZINC HOT DIPPED GALVANIZED MATERIAL TO MEET ASTM A500 GRADE B.
6. SURFACE MOUNTS TO BE USED ONLY AT THE DISCRETION OF TRAFFIC ENGINEER OR RIGHT-OF-WAY INSPECTOR.
7. DRY-PACK CONCRETE: MUST BE BAGGED PREMIX CONCRETE CONTAINING WELL GRADED AGGREGATE, SAND, AND CEMENT, MIXED WITH APPROXIMATELY 1 QUART OF WATER PER 60 POUND BAG, OR ANY CONCRETE APPROVED BY THE ENGINEER.



PUBLICATION DATE: <b>3/1/2022</b>	REVISION DATE: <b>10/6/2021</b>
STANDARD DETAIL NUMBER: <b>510</b>	SCALE: <b>NOT TO SCALE</b>

**2 INCH SQUARE METAL POST  
INSTALLATION**



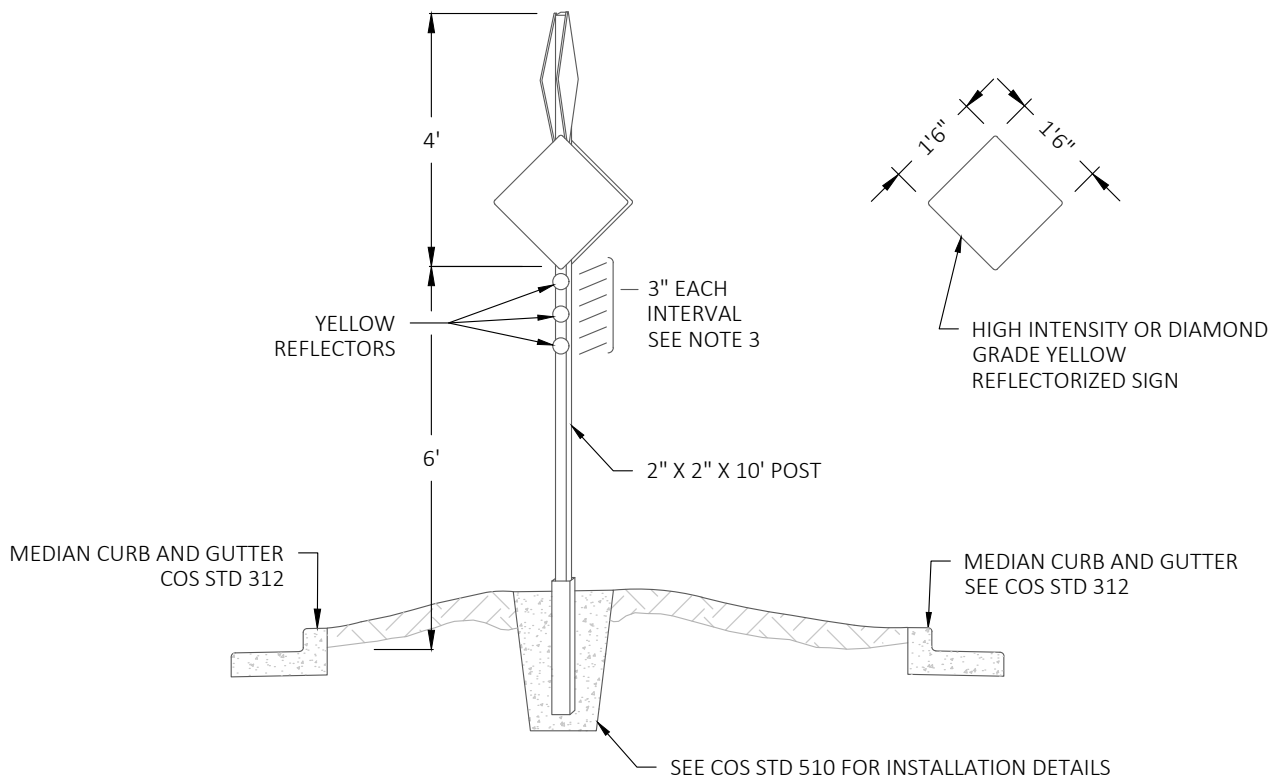

NOTES:

1. IN THE CASE WHERE ALL APPROACHES OF THE INTERSECTION ARE PRIMARILY AT THE SAME LEVEL WITH RESPECT TO GRADES (LESS THAN 3%) THE LOWER SET OF SIGNS WILL FACE THE HIGHER VOLUME STREET.
2. IN THE CASE WHERE AN APPROACH HAS A GRADE LARGER THAN 3% THE HIGHER SIGNS WILL FACE THE APPROACH WITH THE HIGHEST GRADE TO ALLOW BETTER SIGHT DISTANCE.
3. PLACE A MINIMUM OF THREE (3) REFLECTORS ON EACH AND EVERY SIDE OF POST OR PLACE THREE (3) HIGH INTENSITY REFLECTORIZED STRIPS COMPLETELY AROUND POST.

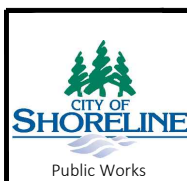

PUBLICATION DATE: <b>3/1/2022</b>	REVISION DATE: <b>2/11/2020</b>
STANDARD DETAIL NUMBER: <b>512</b>	SCALE: <b>NOT TO SCALE</b>

## OBJECT MARKER INSTALLATION

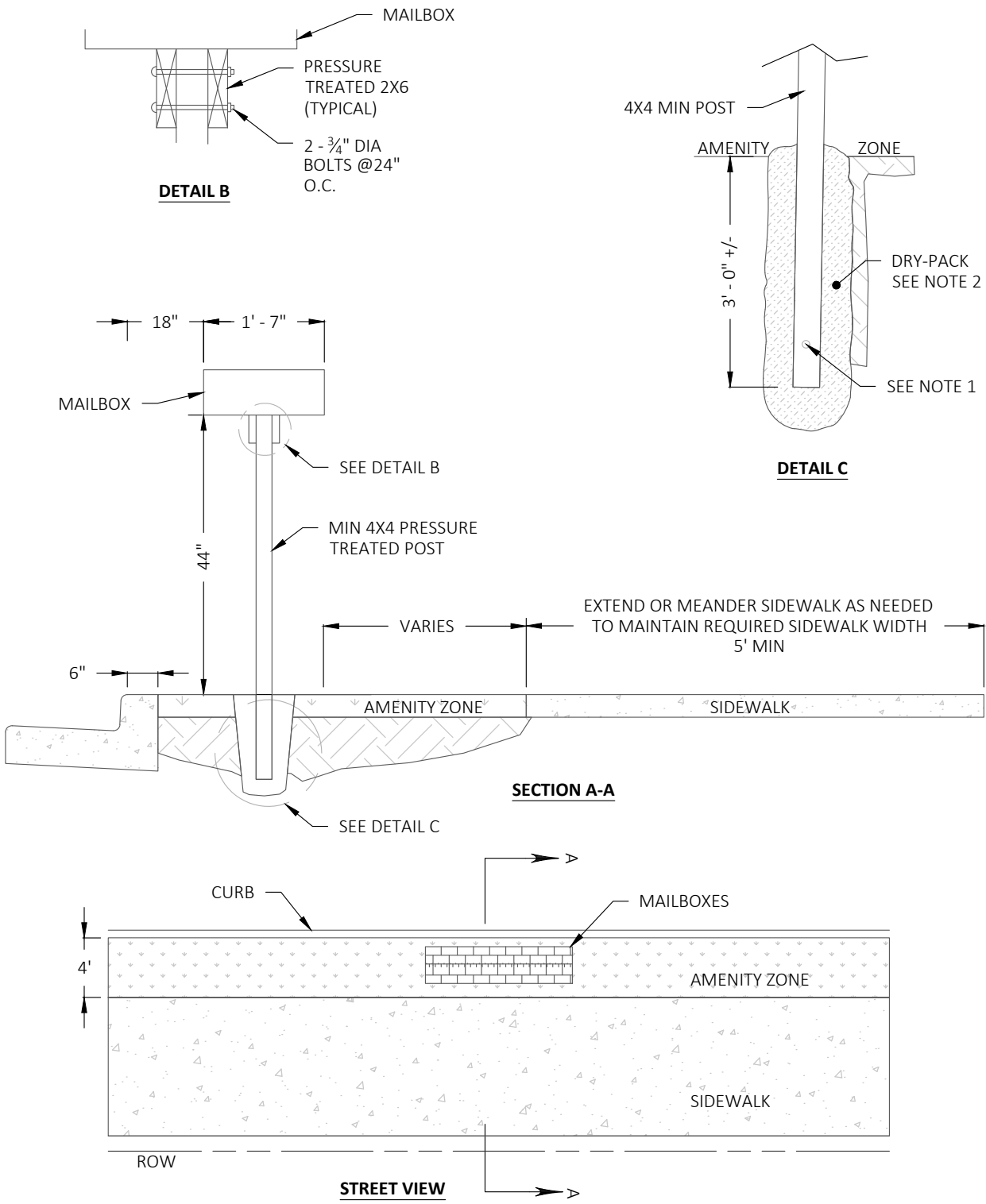

**NOTE:**

1. OBTAIN LOCATION APPROVAL FROM LOCAL POSTMASTER.
2. DRY-PACK CONCRETE: MUST BE BAGGED PREMIX CONCRETE CONTAINING WELL GRADED AGGREGATE, SAND, AND CEMENT, MIXED WITH APPROXIMATELY 1 QUART OF WATER PER 60 POUND BAG, OR ANY CONCRETE APPROVED BY THE ENGINEER.

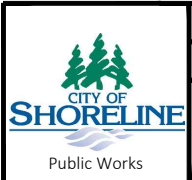

PUBLICATION DATE: <b>3/1/2022</b>	REVISION DATE: <b>2/10/2021</b>
STANDARD DETAIL NUMBER: <b>514</b>	SCALE: <b>NOT TO SCALE</b>

**MAILBOX STAND (NON-ARTERIAL)**

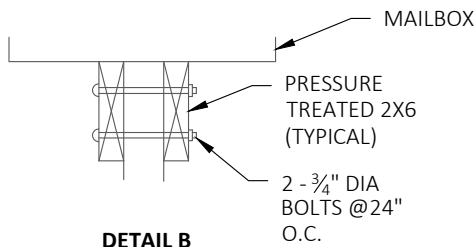

**DETAIL B**

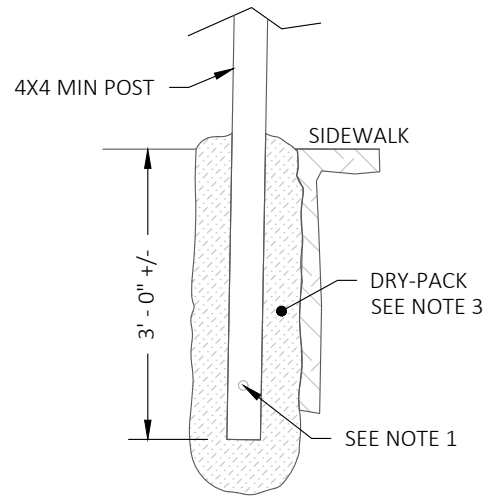

**DETAIL C**

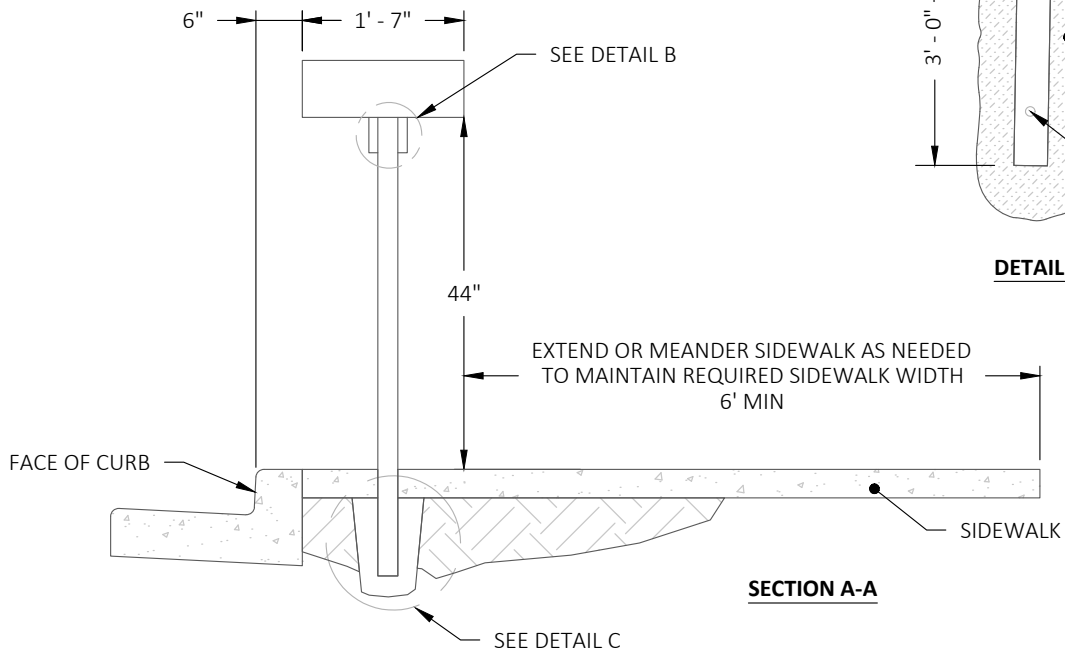

**SECTION A-A**

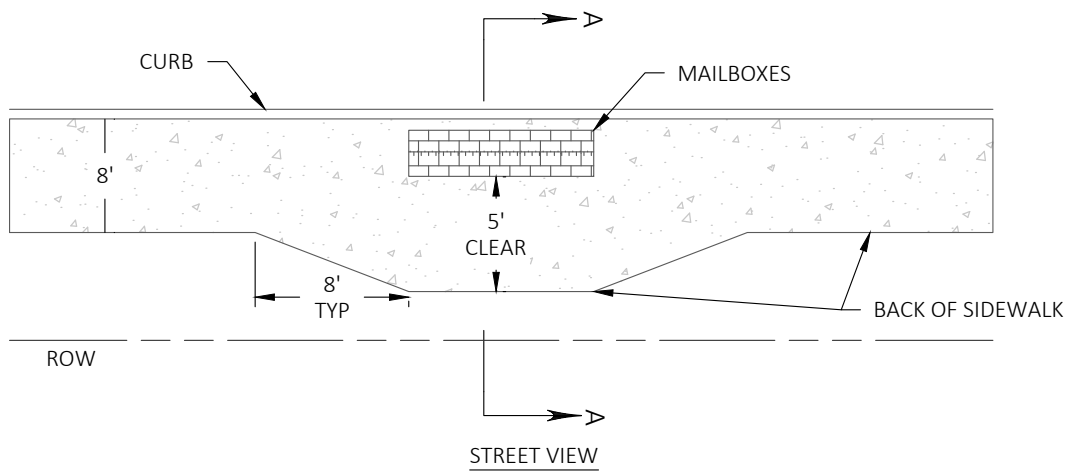

**NOTE:**

1. OBTAIN LOCATION APPROVAL FROM LOCAL POSTMASTER.
2. SHALL BE USED ONLY TO MATCH EXISTING CONDITIONS OR WITH DIRECTORS APPROVAL.
3. DRY-PACK CONCRETE: MUST BE BAGGED PREMIX CONCRETE CONTAINING WELL GRADED AGGREGATE, SAND, AND CEMENT, MIXED WITH APPROXIMATELY 1 QUART OF WATER PER 60 POUND BAG, OR ANY CONCRETE APPROVED BY THE ENGINEER.

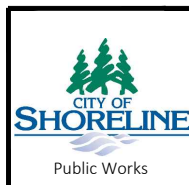

PUBLICATION DATE: <b>3/1/2022</b>	REVISION DATE: <b>2/10/2021</b>
STANDARD DETAIL NUMBER: <b>515</b>	SCALE: <b>NOT TO SCALE</b>

**MAILBOX STAND WITHOUT AMENITY ZONE**

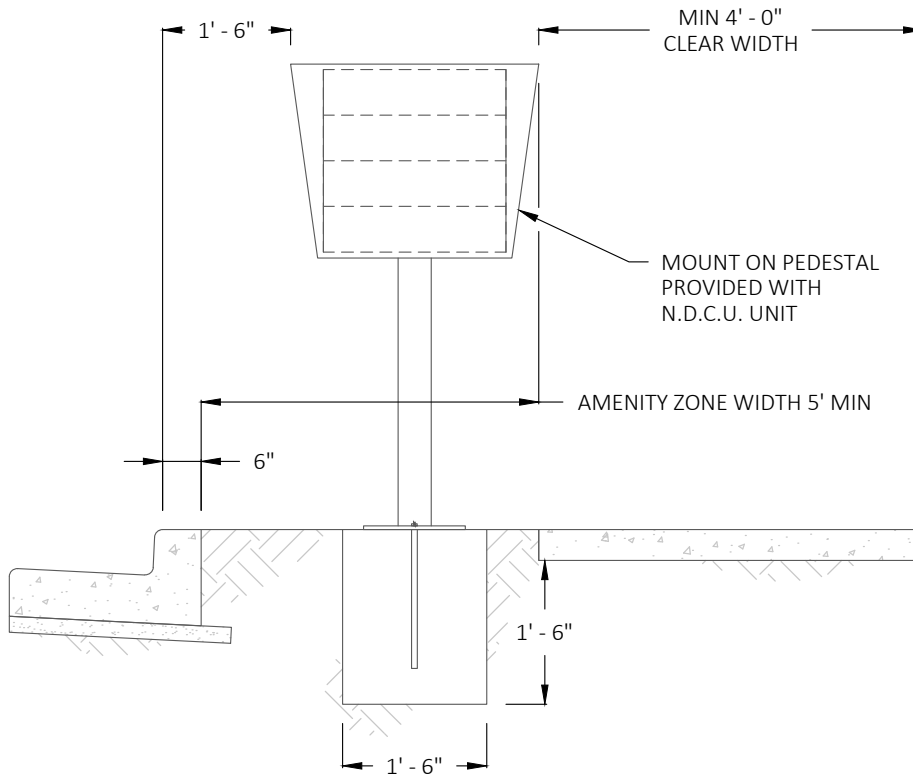

**SIDE VIEW**

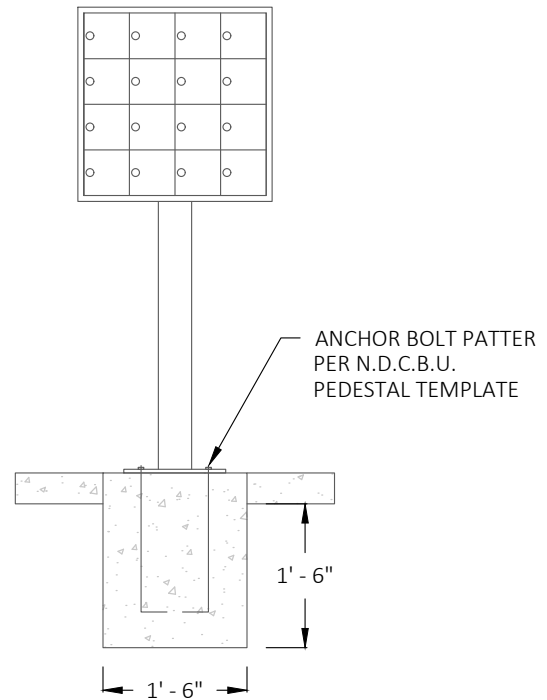

**FRONT VIEW**

**NOTES:**

1. OBTAIN LOCATION APPROVAL FROM LOCAL POSTMASTER.

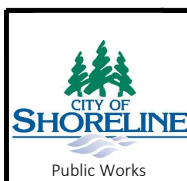

PUBLICATION DATE: **3/1/2022**

REVISION DATE: **2/11/2020**

STANDARD DETAIL NUMBER: **516**

SCALE: **NOT TO SCALE**

**NEIGHBORHOOD DELIVERY &  
COLLECTION BOX UNIT INSTALLATION**

**POST MOUNTED STREET NAME SIGN FOR PRIVATE ROADS**



**POST MOUNTED STREET NAME SIGN**



**MAST ARM (OVERHEAD) MOUNTED STREET NAME SIGN**



**NOTES:**

1. TEXT: FHWA SERIES B.
2. SQUARE/ NO BORDER.
3. COLOR AND RETROREFLECTION SHALL BE CONSISTENT WITH CURRENT MUTCD STANDARDS.
4. FOR SCALABLE LOGO, PLEASE CONTACT CITY OF SHORELINE TRAFFIC SERVICES.
5. FOR NUMBERED STREETS, OMIT NUMERICAL SUFFIXES "ST", "RD", "TH", "ND".

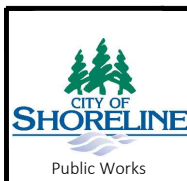

PUBLICATION DATE: <b>3/1/2022</b>	REVISION DATE: <b>2/11/2020</b>
STANDARD DETAIL NUMBER: <b>517</b>	SCALE: <b>NOT TO SCALE</b>

**STREET NAME SIGN**

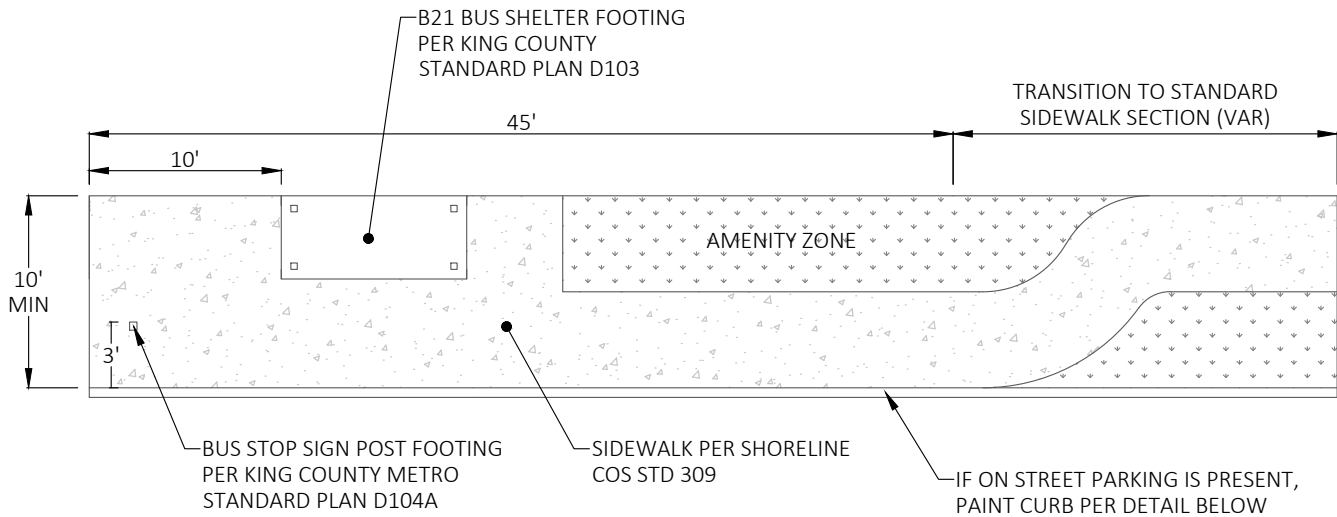

**NOTES**

1. THE TOTAL 45 FT LONG BUS ZONE AREA MAY BE REDUCED TO 20 FT MIN DEPENDING ON SITE CONSTRAINTS.
2. NOT FOR USE ON AURORA AVE N.
3. SHELTER FOOTING AND AMENITY ZONE POSITIONS CAN BE MODIFIED TO ACCOMMODATE DRIVEWAYS, HOWEVER A 10 FT X 10 FT CLEAR AREA MUST BE RETAINED ADJACENT TO THE BUS STOP SIGN FOR COMPLIANCE WITH ADA STANDARDS.
4. ADDITIONAL ELEMENTS MAY BE REQUIRED DEPENDING ON THE TYPE AND USE OF THE STOP.

**BUS ZONE LAYOUT**

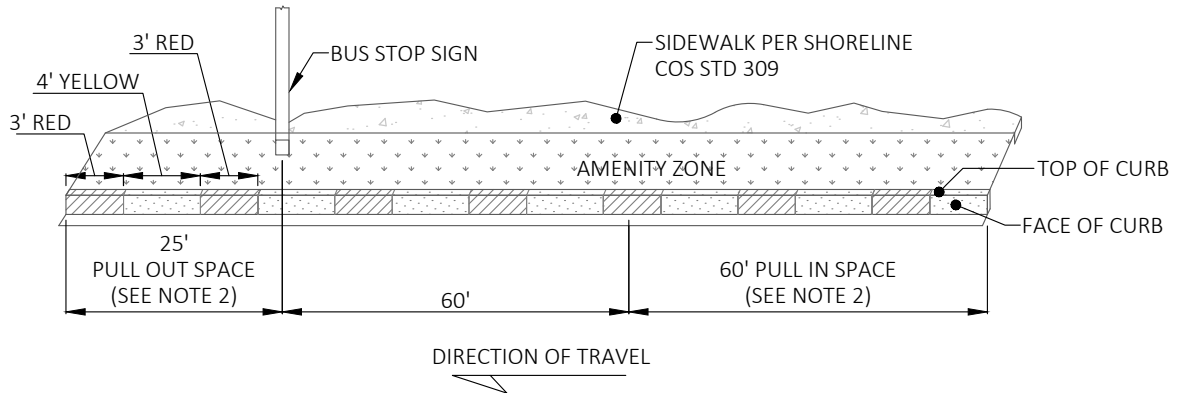

**NOTES**

1. PAINT MUST BE APPLIED ON THE TOP AND FACE OF CURB
2. THE 25' CURB PAINT FOR PULL OUT SPACE, AND THE 60' CURB PAINT FOR PULL IN SPACE MAY VARY DEPENDING ON BUS STOP PROXIMITY TO INTERSECTION

**BUS ZONE CURB PAINT DETAIL**

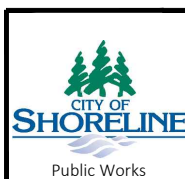

PUBLICATION DATE: <b>3/1/2022</b>	REVISION DATE: <b>2/11/2020</b>
STANDARD DETAIL NUMBER: <b>520</b>	SCALE: <b>NOT TO SCALE</b>

**BUS STOP IMPROVEMENTS**