

**SECTION A-A (TYPICAL)**

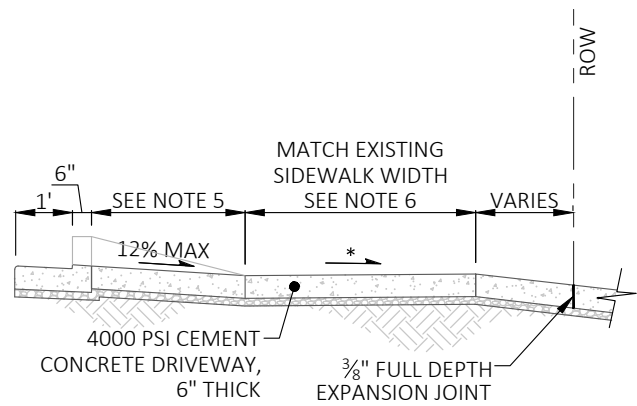

**SECTION A-A (REVERSE SLOPE)**

**LEGEND**

\* 1.5% OR FLATTER RECOMMENDED FOR DESIGN/FORMWORK (2% MAX)

**NOTES:**

1. MATERIAL - WSDOT CONCRETE CLASS 4000psi.
2. FULL DEPTH EXPANSION JOINT SHALL BE INSTALLED ON CENTERLINE WHEN DRIVEWAY WIDTH IS 16' OR GREATER AND ON ALL COMMERCIAL/INDUSTRIAL DRIVEWAYS
3. CURB SHALL BE IN COMPLIANCE WITH COS STD 312.
4. NO REBAR SHALL BE PLACED IN CURB, GUTTER, DRIVEWAY, OR SIDEWALK.
5. DRIVEWAY APPROACH SHALL MATCH AMENITY ZONE WIDTH. IF NO AMENITY ZONE IS PRESENT DRIVEWAY APPROACH SHALL BE 3'.
6. SIDEWALK SHOULD NOT BE NARROWED DOWN THROUGH DRIVEWAY APPROACH, AND SHALL BE ADA COMPLIANT.
7. CURB TRANSITION (DRIVEWAY WING) SHALL BE 2'-6" ON RESIDENTIAL STREETS, AND 5' ON ARTERIAL AND COLLECTOR STREETS.
8. THE USE OF REVERSE SLOPE MUST BE APPROVED BY THE ENGINEER.
9. CURB HEIGHT THROUGH THE DRIVEWAY SHALL BE 1/2" UNLESS A REVERSE SLOPE IS USED. WHEN A REVERSE SLOPE IS USED CURB HEIGHT THROUGH THE DRIVEWAY SHALL BE 2".
10. CRUSHED SURFACING TOP COURSE PER COS STD 309.

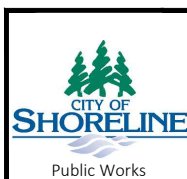

PUBLICATION DATE:	REVISION DATE: <b>09/15/2022</b>
STANDARD DETAIL NUMBER: <b>301</b>	SCALE: <b>NOT TO SCALE</b>

**DRIVEWAY APPROACH**

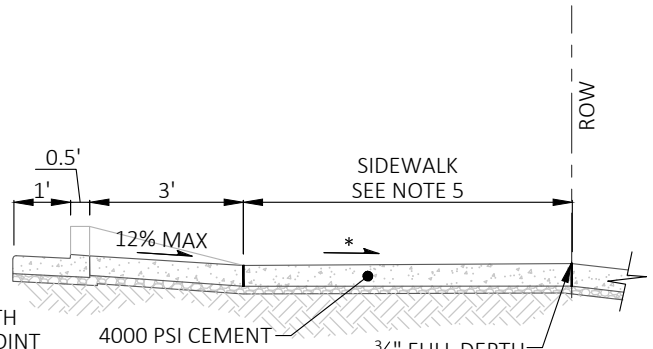
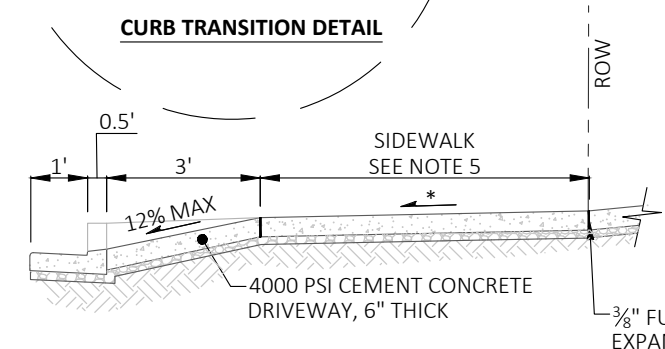
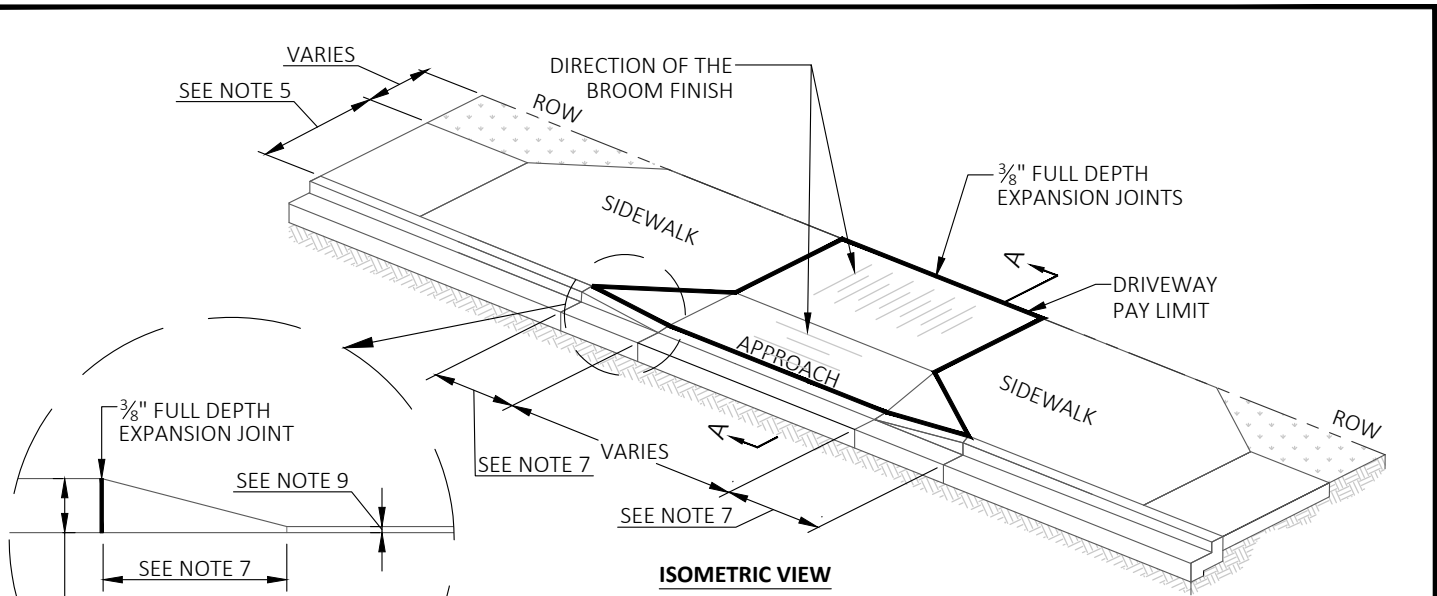

**SECTION A-A (TYPICAL)**

**SECTION A-A (REVERSE SLOPE)**

**LEGEND**

\* 1.5% OR FLATTER RECOMMENDED FOR DESIGN/FORMWORK (2% MAX)

**NOTES:**

1. MATERIAL - WSDOT CONCRETE CLASS 4000psi.
2. FULL DEPTH EXPANSION JOINT SHALL BE INSTALLED ON CENTERLINE WHEN DRIVEWAY WIDTH IS 16' OR GREATER AND ON ALL COMMERCIAL/INDUSTRIAL DRIVEWAYS
3. CURB SHALL BE IN COMPLIANCE WITH COS STD 312.
4. NO REBAR SHALL BE PLACED IN CURB, GUTTER, DRIVEWAY, OR SIDEWALK.
5. SIDEWALK SHALL BE ADA COMPLIANT.
6. SIDEWALK THROUGH DRIVEWAY APPROACH MAY REQUIRE A PERMANENT EASEMENT.
7. CURB TRANSITION (DRIVEWAY WING) SHALL BE 2'-6" ON RESIDENTIAL STREETS, AND 5' ON ARTERIAL AND COLLECTOR STREETS.
8. THE USE OF REVERSE SLOPE MUST BE APPROVED BY THE ENGINEER.
9. CURB HEIGHT THROUGH THE DRIVEWAY SHALL BE 1/2" UNLESS A REVERSE SLOPE IS USED. WHEN A REVERSE SLOPE IS USED CURB HEIGHT THROUGH THE DRIVEWAY SHALL BE 2", PER COS STD 312.
10. CRUSHED SURFACING TOP COURSE PER COS STD 309.



PUBLICATION DATE:	REVISION DATE: <b>09/15/2022</b>
STANDARD DETAIL NUMBER: <b>302</b>	SCALE: <b>NOT TO SCALE</b>

**DRIVEWAY APPROACH - NO AMENITY ZONE**

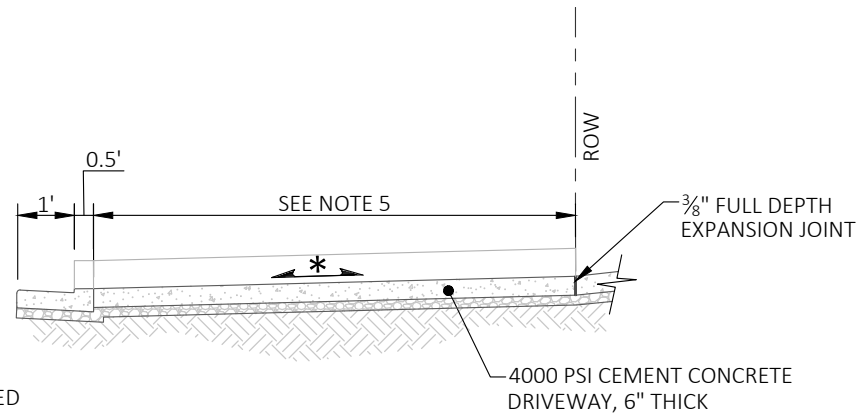
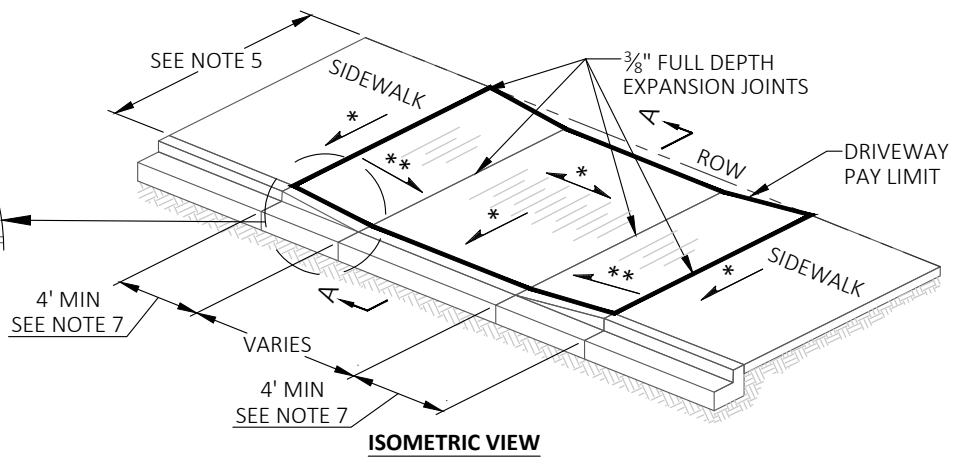
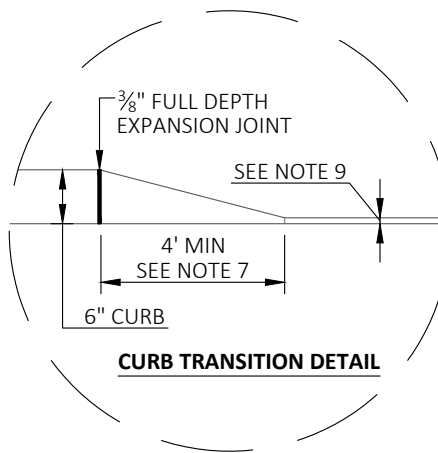

**LEGEND**

- \* 1.5% OR FLATTER RECOMMENDED FOR DESIGN/FORMWORK (2% MAX)
- \*\* 7.5% OR FLATTER RECOMMENDED FOR DESIGN / FORMWORK (8.33% MAX)

**NOTES:**

1. MATERIAL - WSDOT CONCRETE CLASS 4000psi.
2. FULL DEPTH EXPANSION JOINT SHALL BE INSTALLED ON CENTERLINE WHEN DRIVEWAY WIDTH IS 16' OR GREATER AND ON ALL COMMERCIAL/INDUSTRIAL DRIVEWAYS
3. CURB SHALL BE IN COMPLIANCE WITH COS STD 312.
4. NO REBAR SHALL BE PLACED IN CURB, GUTTER, DRIVEWAY, OR SIDEWALK.
5. SIDEWALK SHOULD BE 8' WIDE AND MAINTAIN 8' WIDTH THROUGH DRIVEWAY. SIDEWALK SHALL BE ADA COMPLIANT.
6. THE USE OF REVERSE SLOPE MUST BE APPROVED BY THE ENGINEER.
7. DRIVEWAY APRON WIDTH SHALL BE 4' MIN, 15' MAX AND SHALL BE DESIGNED TO BE ADA COMPLIANT.
8. DROP DOWN DRIVEWAYS SHOULD NOT BE USED UNLESS ALL OTHER DRIVEWAY TYPES ARE INFEASIBLE AND MUST BE APPROVED BY THE ENGINEER.
9. CURB HEIGHT THROUGH THE DRIVEWAY SHALL BE 1/2" UNLESS A REVERSE SLOPE IS USED. WHEN A REVERSE SLOPE IS USED CURB HEIGHT THROUGH THE DRIVEWAY SHALL BE 2".
10. CRUSHED SURFACING TOP COURSE PER COS STD 309.
11. CURB BROOM FINISH SHALL BE PERPENDICULAR TO THE CURB.



PUBLICATION DATE:	REVISION DATE: <b>09/15/2022</b>
STANDARD DETAIL NUMBER: <b>303</b>	SCALE: <b>NOT TO SCALE</b>
<b>DRIVEWAY APPROACH - DROP DOWN</b>	

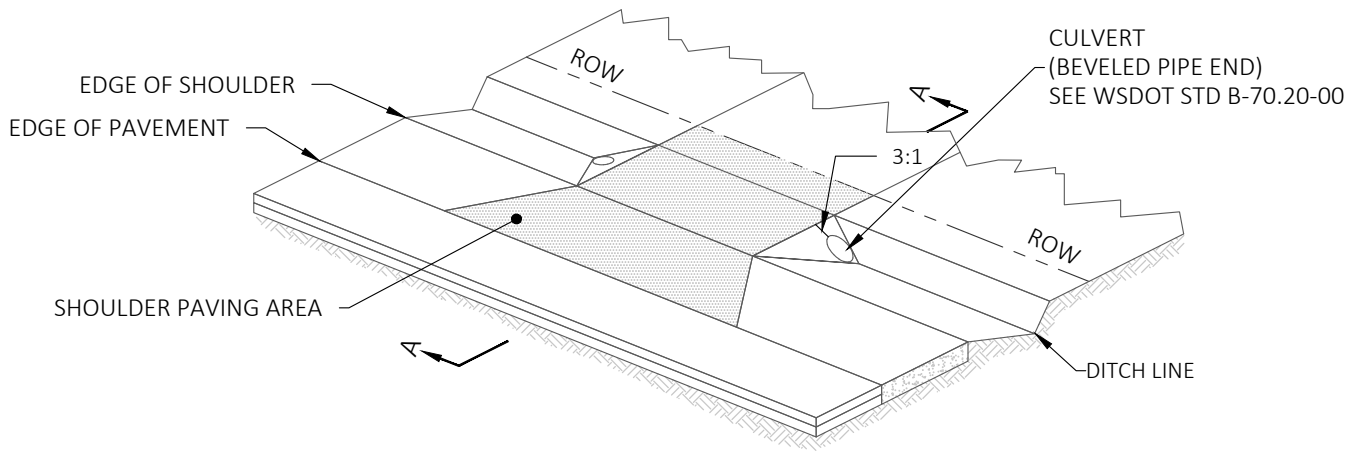

ISOMETRIC VIEW

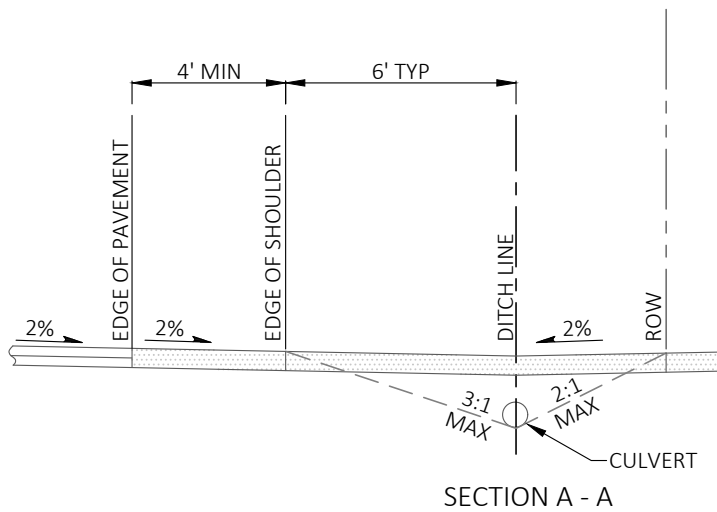

NOTES:

1. ALL COMMERCIAL/INDUSTRIAL DRIVEWAYS SHALL HAVE AN EXPANSION JOINT LOCATED MID-WIDTH.
2. EXPOSED PIPE ENDS SHALL BE BEVELED
3. PIPE COVER SHALL BE IN ACCORDANCE WITH MANUFACTURER'S RECOMMENDATIONS.
4. PIPE SHALL BE INSTALLED IN A STRAIGHT UNIFORM ALIGNMENT AT A MIN. 0.5% SLOPE.
5. DRIVEWAYS SHALL BE PAVED FROM THE EDGE OF PAVEMENT TO THE PROPERTY LINE.
6. PIPES LARGER THAN 18" REQUIRE A TRASH TRACK RACK (COS STD 702).

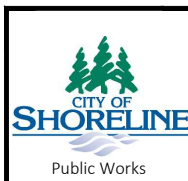

PUBLICATION DATE:	REVISION DATE: <b>02/10/2021</b>
STANDARD DETAIL NUMBER: <b>306</b>	SCALE: <b>NOT TO SCALE</b>
<b>DRIVEWAY APPROACH - SHOULDER &amp; DITCH SECTION</b>	

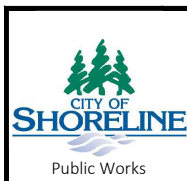
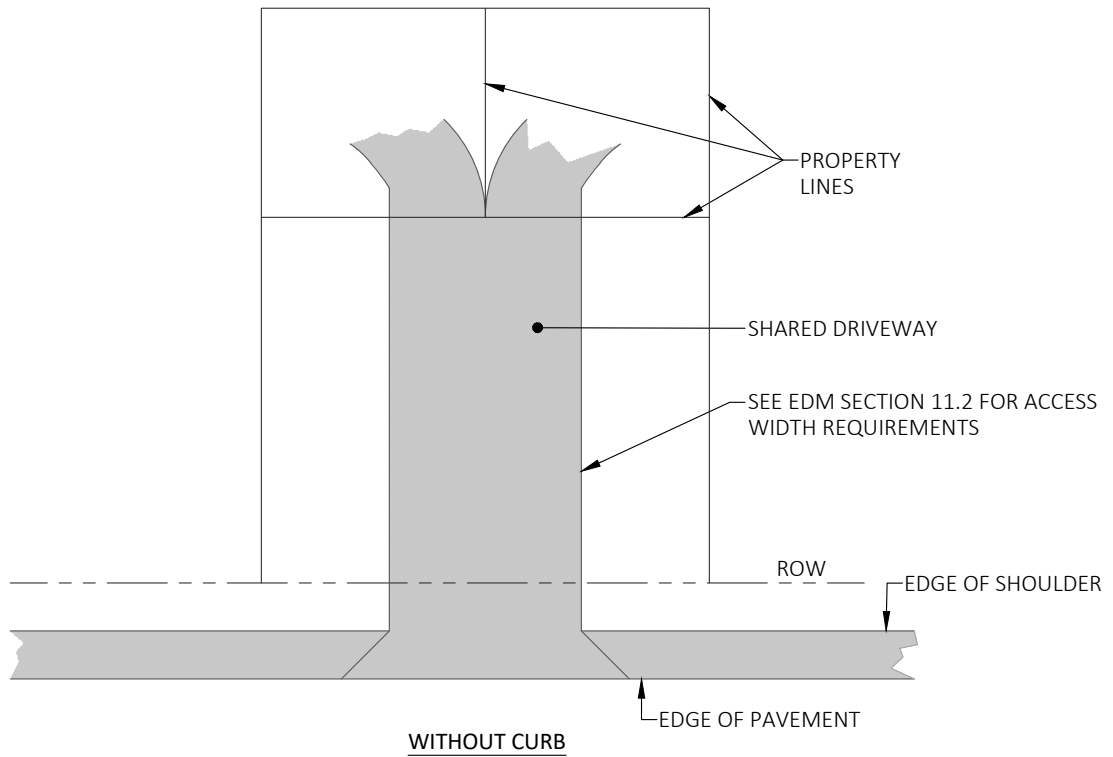
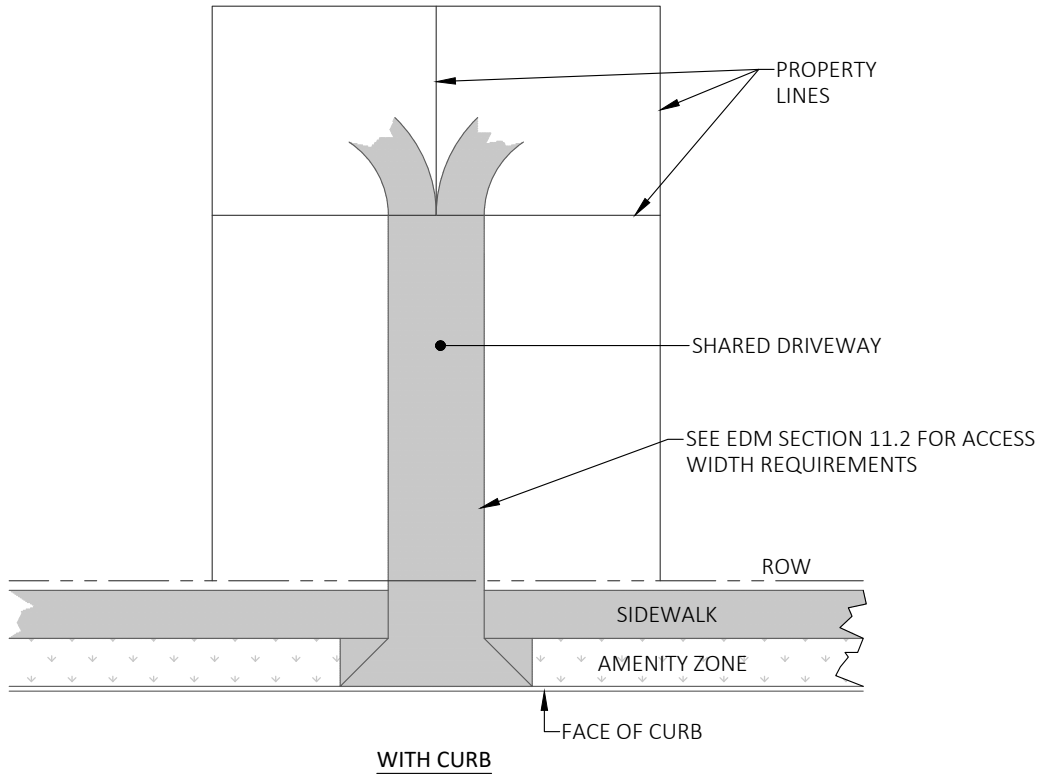

PUBLICATION DATE:

REVISION DATE: **02/10/2021**

STANDARD DETAIL NUMBER: **307**

SCALE: **NOT TO SCALE**

## SHARED DRIVEWAY

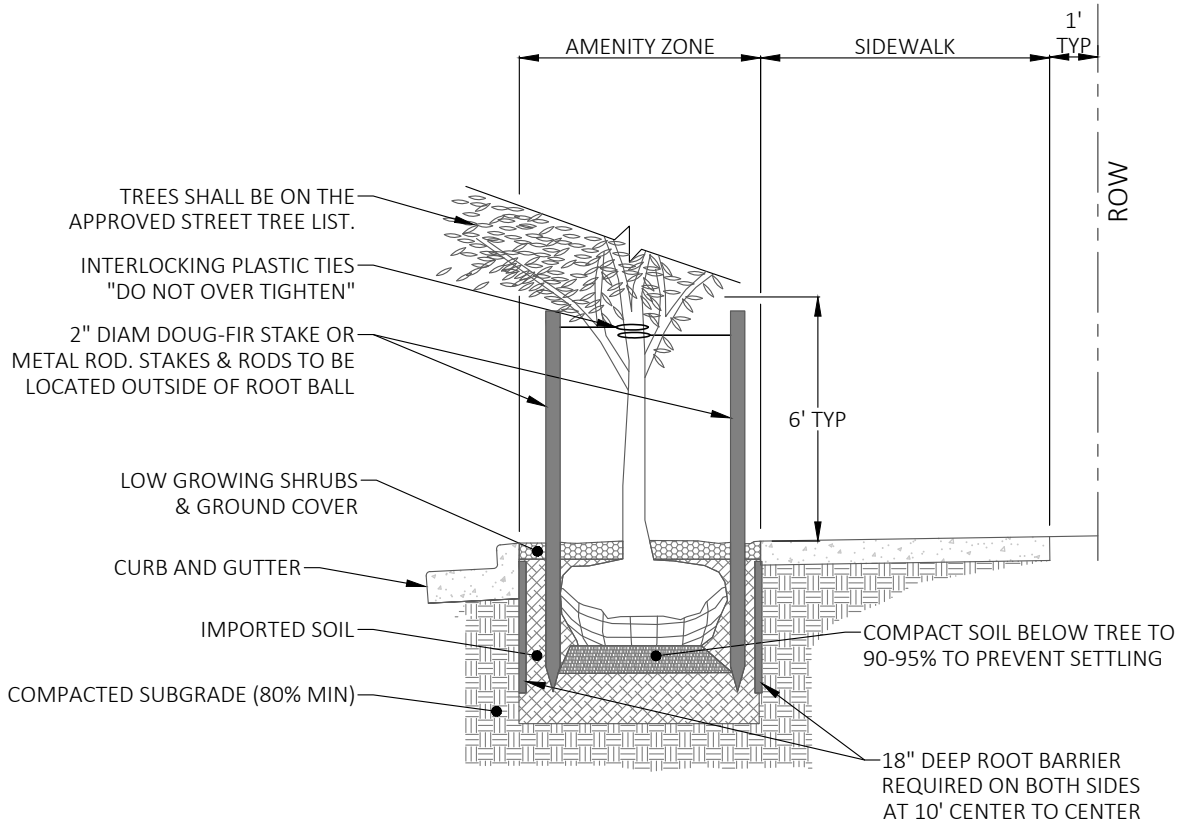

**NOTES:**

1. TREE PIT SHALL NOT BE LESS THAN 2 TIMES ROOT BALL DIAM.
2. CUT ALL TIES & FOLD BACK BURLAP FROM UPPER  $\frac{1}{3}$  OF ROOT BALL. REMOVE ALL METAL CAGING AND BURLAP FROM ROOT BALL.
3. WATER DAILY UNTIL ESTABLISHED, FERTILIZE & USE GROWTH HORMONE.
4. WHERE A CONTINUOUS PLANTING STRIP IS ALLOWED, WIDEN TREE PIT TO SIDEWALK.
5. STREET TREES SHOULD BE CENTERED WITHIN THE AMENITY ZONE.
6. STREET TREES SHOULD BE SPACED 25' OR GREATER ON CENTER. SPACING SHOULD BE DETERMINED BASED ON TREE SPECIES, THE LOCATION OF UTILITIES, AND THE LOCATION OF TRAFFIC CONTROL DEVICES.
7. REFER TO SECTION 15.2 OF THE EDM FOR ADDITIONAL LANDSCAPING REQUIREMENTS.
8. FOR AMENITY ZONE WIDTH REFER TO THE EDM APPENDIX F.
9. STREET TREE REPLACEMENT SHALL BE PER SMC CHAPTER 12.30.040.
10. SOILS IN AMENITY ZONES SHOULD BE COMPLIANT WITH BMP T5.13. SEE COS STANDARD DETAIL 774 FOR SOIL AMENDMENT REQUIREMENTS.



PUBLICATION DATE:	REVISION DATE: <b>09/15/2022</b>
STANDARD DETAIL NUMBER: <b>308</b>	SCALE: <b>NOT TO SCALE</b>

**AMENITY ZONE**

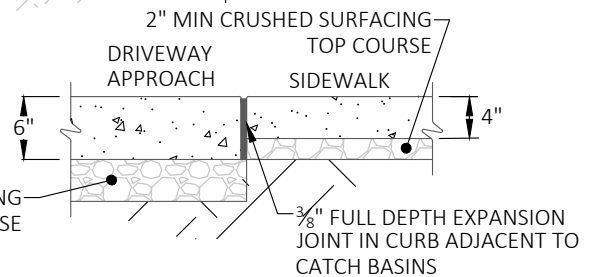
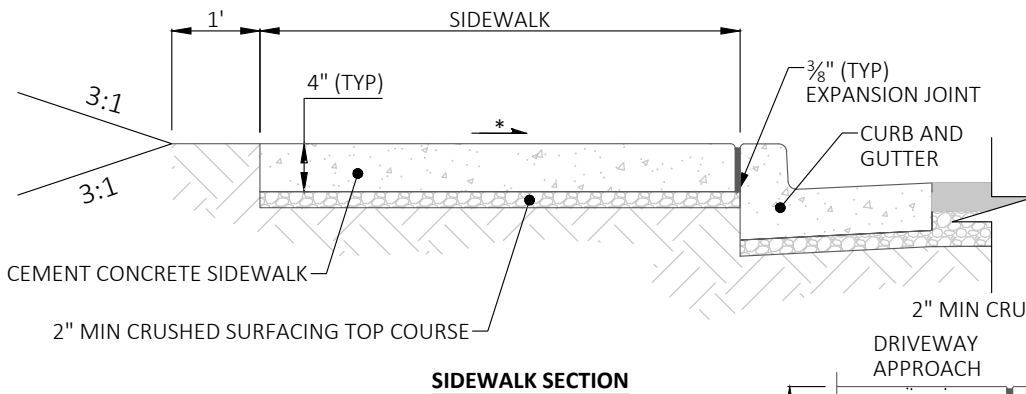
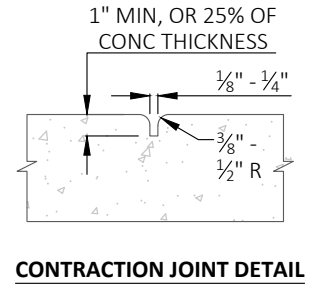
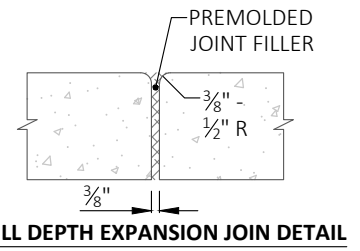
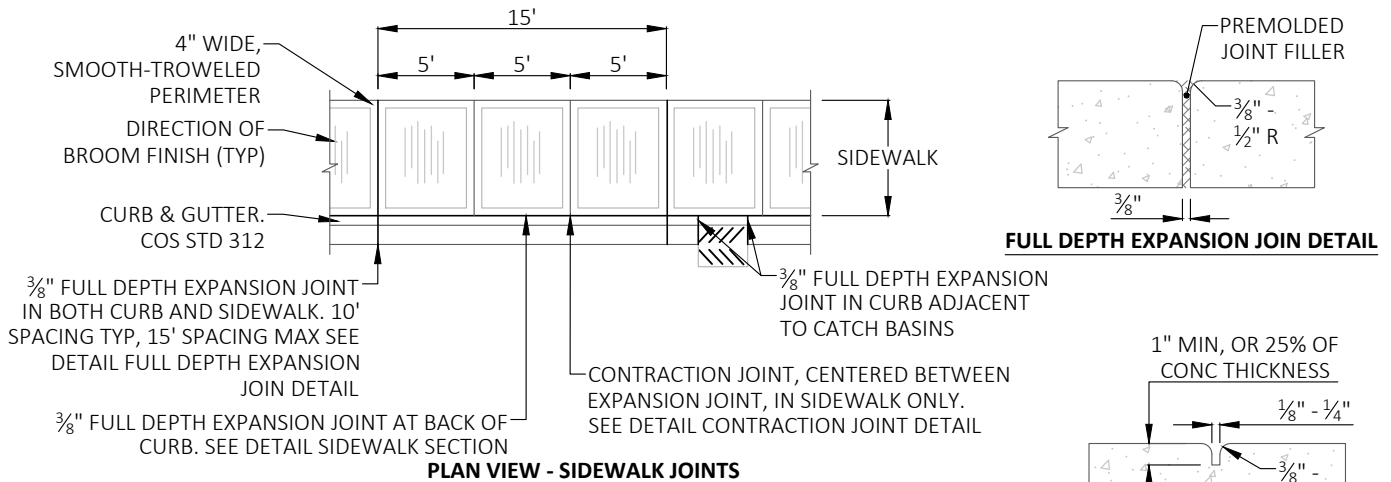

**LEGEND**

\* 1.5% OR FLATTER RECOMMENDED FOR DESIGN/FORMWORK (2% MAX)

**NOTES:**

- SIDEWALK AND CURB & GUTTER SHALL NOT BE POURED MONOLITHICALLY.
- NO REBAR SHALL BE PLACE IN CURB, GUTTER DRIVEWAY APPROACH, OR SIDEWALK.
- AN EXPANSION JOINT WILL BE REQUIRED WHEN CONCRETE SIDEWALK IS SURROUNDED BY OTHER HARD SURFACES (CURB & GUTTER, CURB RAMPS, DRIVEWAYS, ETC.) OR AS DIRECTED BY THE CITY ENGINEER.
- EXPANSION JOINTS SHALL BE INSTALLED AROUND FIRE HYDRANTS, POLES, POSTS, UTILITY CASTINGS, AND ALONG WALLS OR STRUCTURES IN PAVED AREAS.
- CONTRACTION/CONTROL JOINT SHALL BE 1/4" SIDE BY 25% SLAB DEPTH; 1" DEEP FOR 4"SLAB, 1.5 DEEP FOR 6"SLAB, 2" DEEP FOR 8" SLAB, AT 5' SPACING.
- SIDEWALK SHALL BE ADA COMPLIANT.
- LIDS FOR JUNCTION BOXES AND UTILITY VAULTS SHALL BE NON-SKID, FLUSH WITH THE SURFACE, AND MATCH THE GRADE OF THE SIDEWALK.
- CONCRETE SHALL BE CLASS 3000 PER SECTION 6-02 OF WSDOT STANDARD SPECIFICATIONS.
- REMOVAL/REPLACEMENT OF CEMENT CONCRETE SIDEWALK SHALL BE FROM EXPANSION JOINT TO EXPANSION JOINT UNLESS OTHERWISE DIRECTED BY THE CITY ENGINEER.
- SIDEWALK SHALL BE CONSTRUCTED IN ACCORDANCE WITH SECTION 8-14 OF WSDOT STANDARD SPECIFICATIONS AND AS SHOWN ON THE STANDARD DETAILS.

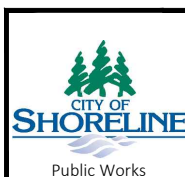

PUBLICATION DATE:

REVISION DATE: **09/15/2022**

STANDARD DETAIL NUMBER: **309**

SCALE: **NOT TO SCALE**

**SIDEWALK DETAIL**

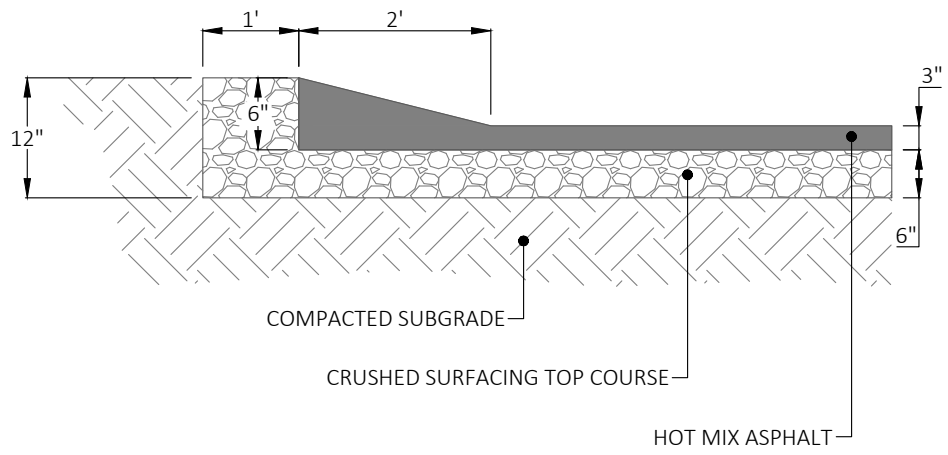

	PUBLICATION DATE:	REVISION DATE: <b>02/11/2020</b>
	STANDARD DETAIL NUMBER: <b>310</b>	SCALE: <b>NOT TO SCALE</b>
<b>ASPHALT THICKENED EDGE</b>		



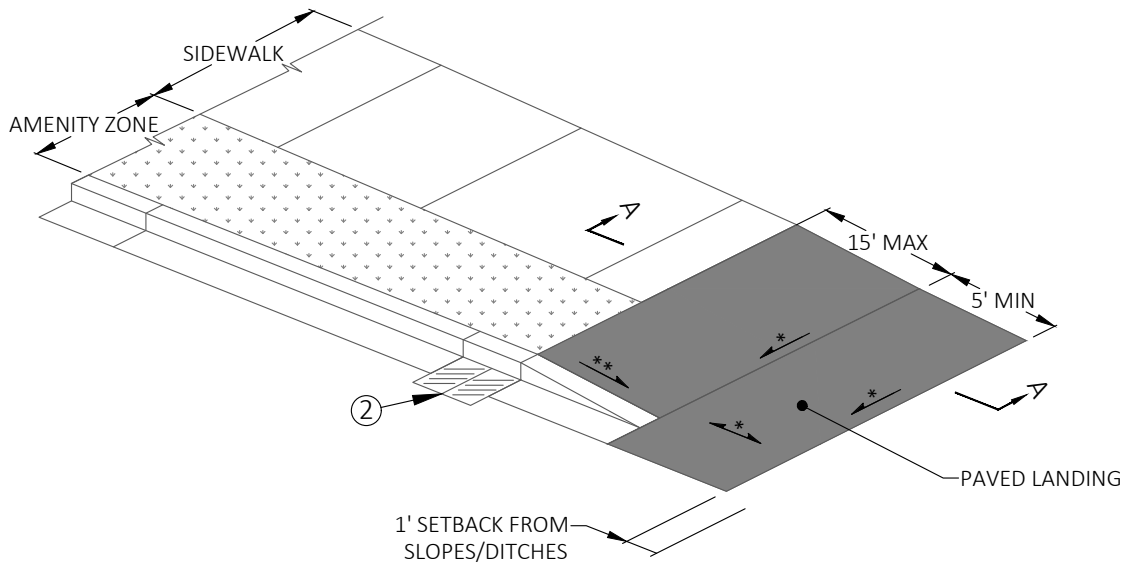

**ISOMETRIC VIEW**

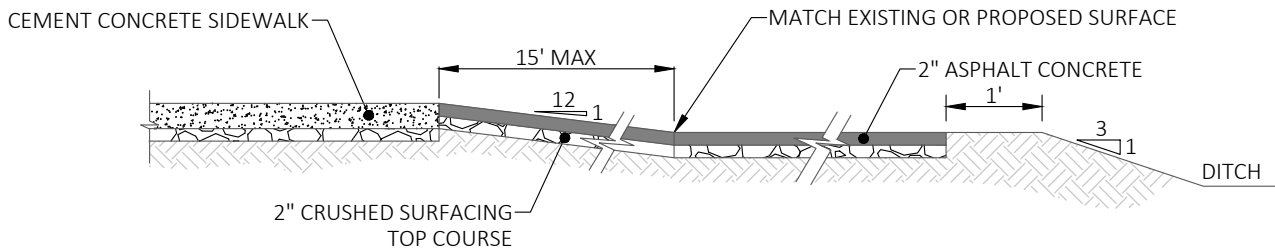

**SECTION A-A**

**LEGEND**

- \* 1.5% OR FLATTER RECOMMENDED FOR DESIGN/FORMWORK (2% MAX)
- \*\* 7.5% OR FLATTER RECOMMENDED FOR DESIGN/FORMWORK (8.33% MAX)

**NOTES:**

1. RAMP, CURB TAPER, AND LANDING ALL ASPHALT OVER 2" CSTC.
- ② LOCATE CATCH BASINS AT END OF IMPROVEMENTS TO FACILITATE FUTURE EXTENSIONS/CONNECTIONS.
3. FOR WIDTHS OF PAVEMENT AND SHOULDER SEE COS STD 201, 204 & 205.
4. FOR TRANSITIONS ADJACENT TO DITCHES, DITCH SLOPING (3:1 TYPICAL), 1' SETBACK & PIPE BEVEL END DESIGN (SEE COS STD 701) MAY BE REQUIRED.
5. FOR CURB AND SIDEWALK JOINTS SEE COS STD 309.
6. CURB RADIUS REQUIRED AT INTERSECTIONS.
7. EXISTING SHOULDER MAY REQUIRE RESTORATION WITH CSTC.

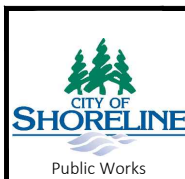

PUBLICATION DATE:	REVISION DATE: <b>07/17/2023</b>
STANDARD DETAIL NUMBER: <b>311</b>	SCALE: <b>NOT TO SCALE</b>
<b>ASPHALT TRANSITION RAMP TO SHOULDER</b>	

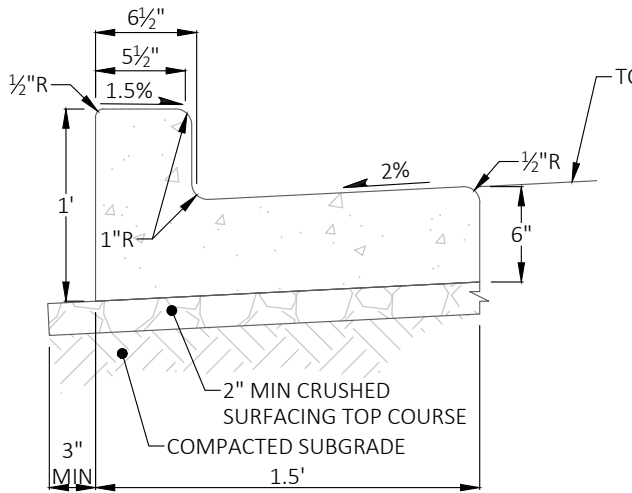

**TYPE A CURB AND GUTTER**

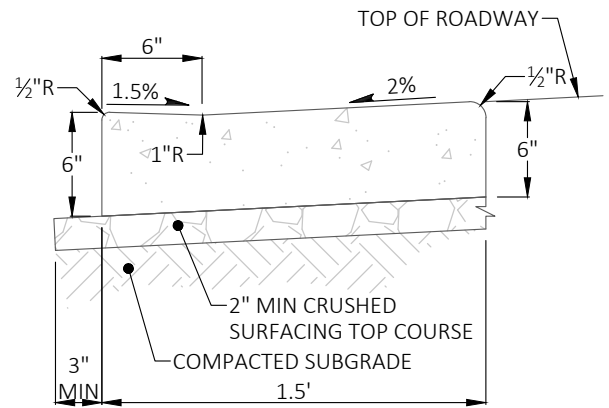

**DEPRESSED CURB AND GUTTER**

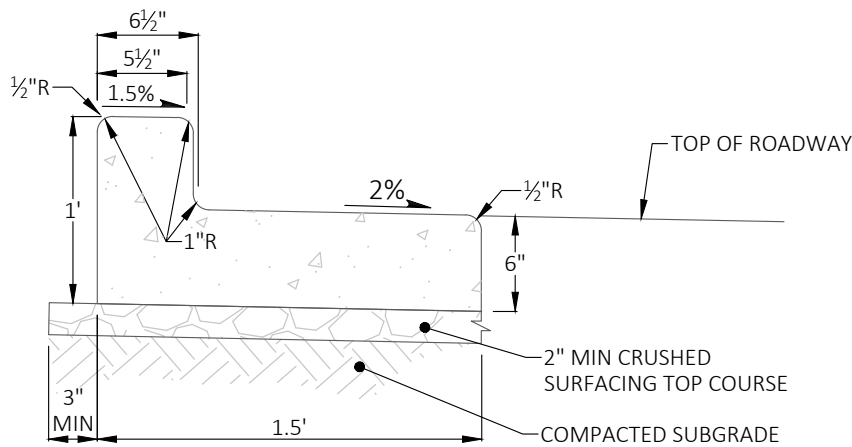

**MEDIAN CURB AND GUTTER**

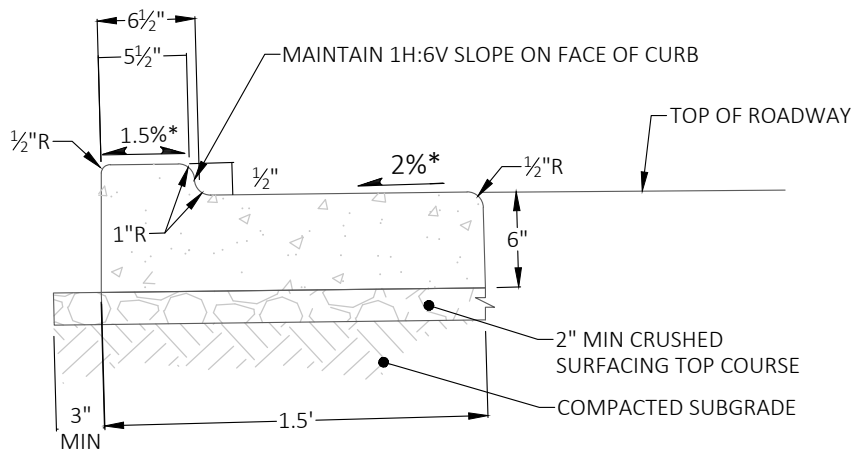

**DRIVEWAY CURB AND GUTTER**

\*REVERSE SLOPE MUST BE APPROVED BY THE ENGINEER

NOTE:  
CONCRETE SHALL BE AIR ENTRAINED CLASS 3000 PER WSDOT STANDARD SPECIFICATIONS 6-02. CLASS 4000 REQUIRED ALONG DRIVEWAY ENTRANCE.

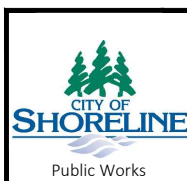

PUBLICATION DATE:

REVISION DATE: **09/15/2022**

STANDARD DETAIL NUMBER: **312**

SCALE: **NOT TO SCALE**

**CURB AND GUTTER**

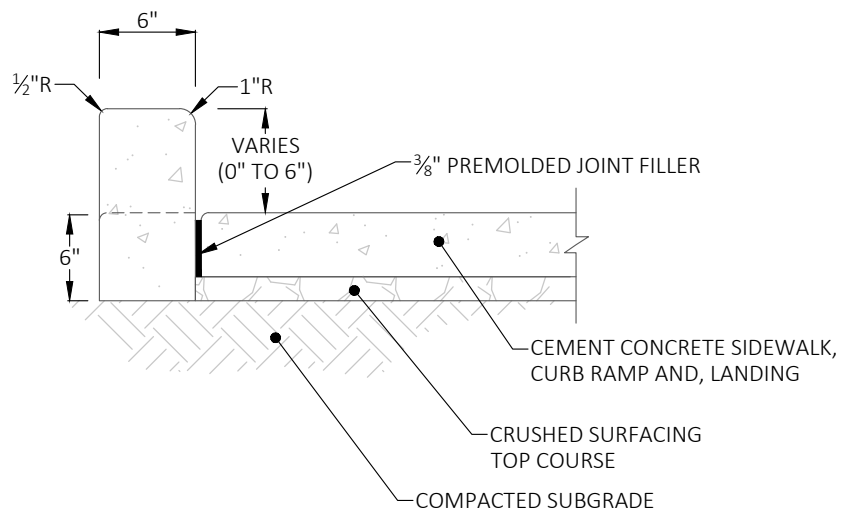

NOTE:  
 CONCRETE SHALL BE AIR ENTRAINED CLASS 3000 PER  
 WSDOT STANDARD SPECIFICATIONS 6-02.

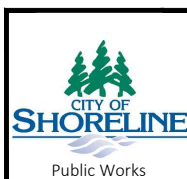

PUBLICATION DATE:

REVISION DATE: **02/11/2020**

STANDARD DETAIL NUMBER: **313**

SCALE: **NOT TO SCALE**

## PEDESTRIAN CURB

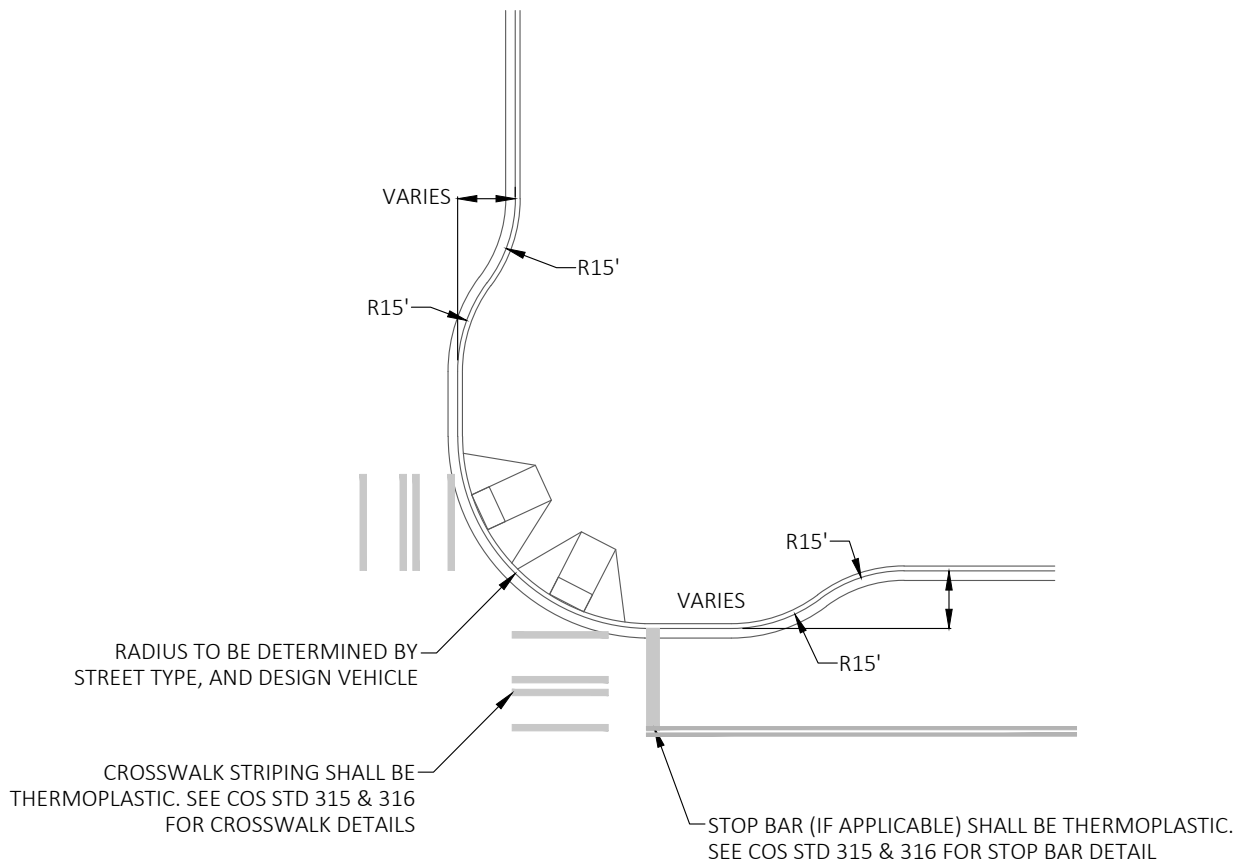

**NOTES:**

1. INTERSECTION RADII SHALL ACCOMMODATE DESIGN VEHICLES APPLICABLE TO STREET.
2. LENGTH OF CURB EXTENSIONS MUST RECOGNIZE SITE CONDITIONS, E.G. DRIVEWAY LOCATIONS.
3. CATCH BASINS SHALL BE INSTALLED AT LOW POINTS ALONG CURB LINE TO PREVENT PONDING.

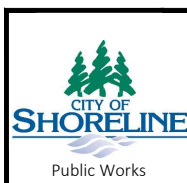

PUBLICATION DATE:

REVISION DATE: **02/11/2020**

STANDARD DETAIL NUMBER: **314**

SCALE: **NOT TO SCALE**

**CURB EXTENSION**

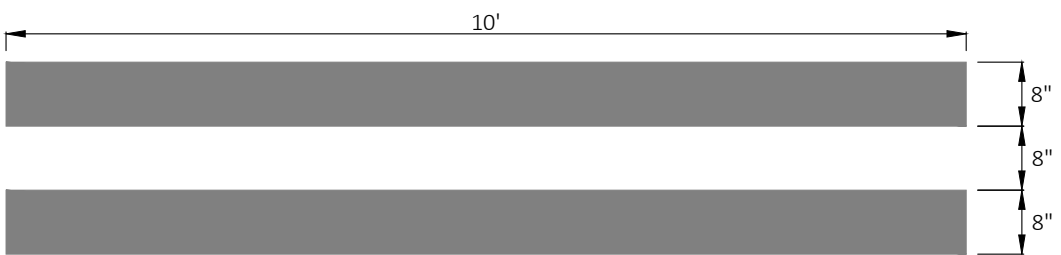
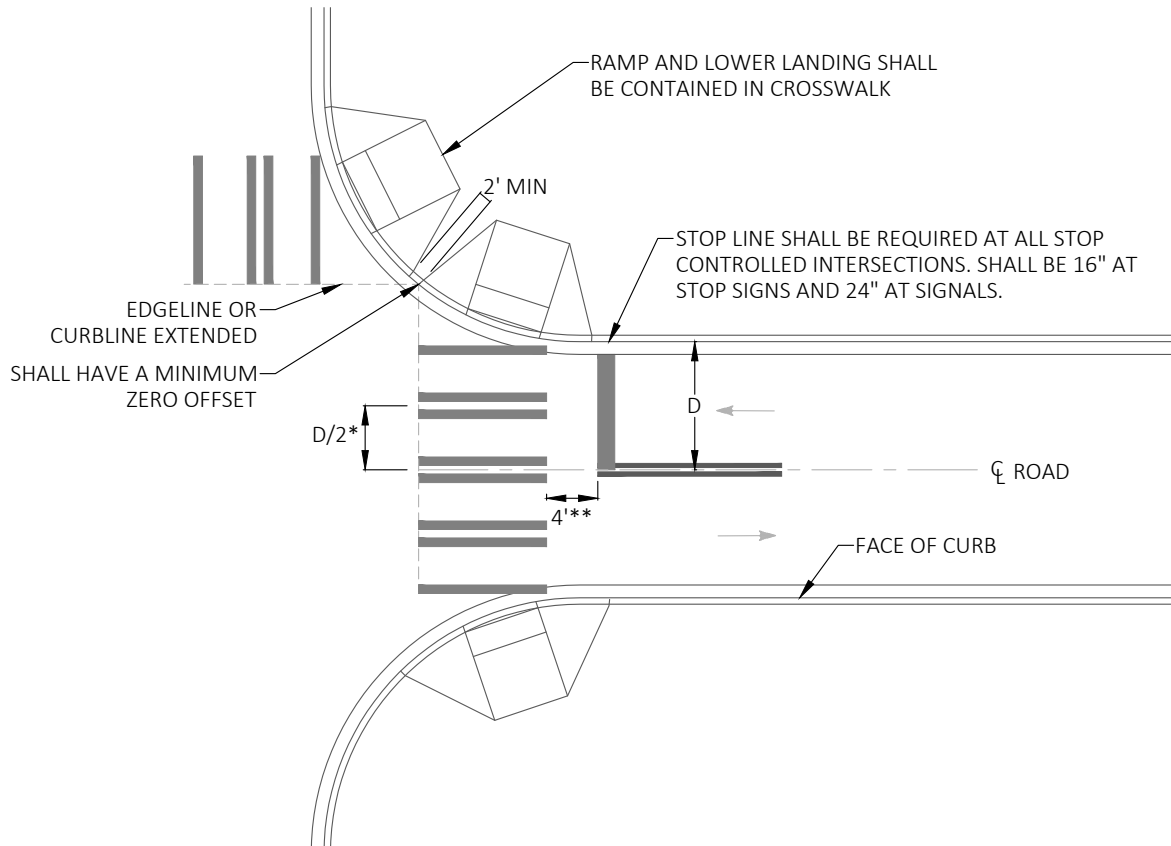

**CROSSWALK DETAIL**

**LEGEND**

- \* USE 5' TYPICAL SPACING IF LANES LINES ARE NOT MARKED
- \*\* STOP LINE SHALL BE LOCATED 4' BEHIND MARKED OR UNMARKED CROSSWALKS
- ← TRAFFIC DIRECTION

**NOTES:**

1. DRAINAGE STRUCTURES SHALL MANAGE SURFACE WATER AT MARKED CROSSWALKS.
2. STOP LINES AND CROSSWALKS SHALL BE THERMOPLASTIC.

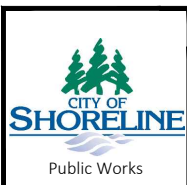

PUBLICATION DATE:	REVISION DATE: <b>10/06/2021</b>
STANDARD DETAIL NUMBER: <b>315</b>	SCALE: <b>NOT TO SCALE</b>

**CROSSWALK WITH SINGLE APPROACH LANE**

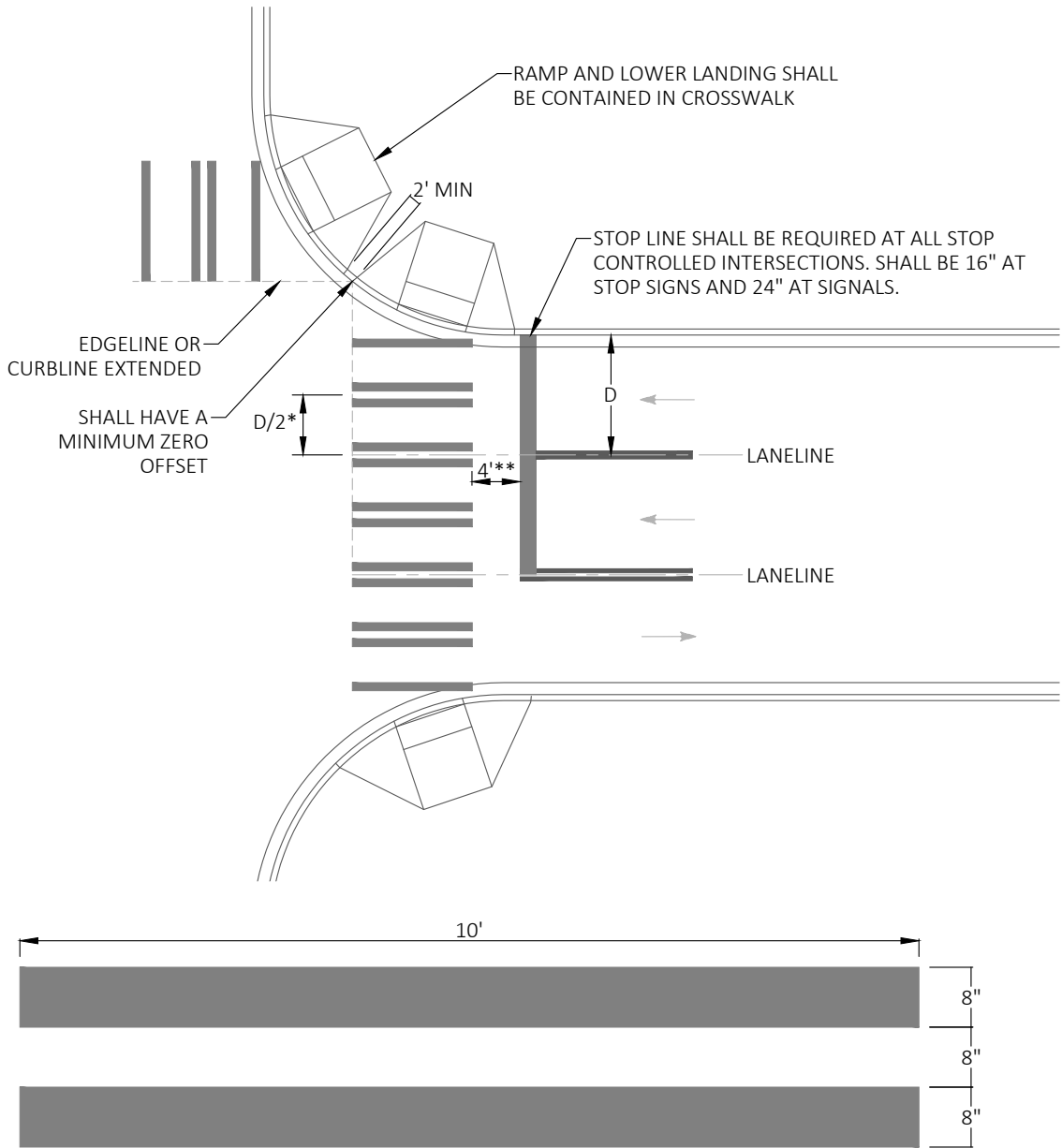

**CROSSWALK DETAIL**

**LEGEND**

- \* USE 5' TYPICAL SPACING IF LANES LINES ARE NOT MARKED
- \*\* STOP LINE SHALL BE LOCATED 4' MIN BEHIND MARKED OR UNMARKED CROSSWALKS. STOP LINE FOR LEFT TURN LANES MAY BE PUSHED BACK, AT THE DISCRETION OF THE ENGINEER, TO ACCOMMODATE OVERSIZED VEHICLES' TURNING MOVEMENTS.
- ← TRAFFIC DIRECTION

**NOTES:**

1. DRAINAGE STRUCTURES SHALL MANAGE SURFACE WATER AT MARKED CROSSWALKS.
2. STOP LINES AND CROSSWALKS SHALL BE THERMOPLASTIC.

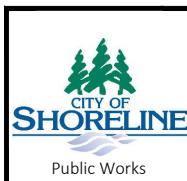

PUBLICATION DATE:	REVISION DATE: <b>10/06/2021</b>
STANDARD DETAIL NUMBER: <b>316</b>	SCALE: <b>NOT TO SCALE</b>

**CROSSWALK WITH MULTIPLE  
APPROACH LANES**

**LEGEND**

- \* 1.5% OR FLATTER RECOMMENDED FOR DESIGN/FORMWORK (2% MAX)
- \*\* 7.5% OR FLATTER RECOMMENDED FOR DESIGN/FORMWORK (8.3% MAX)

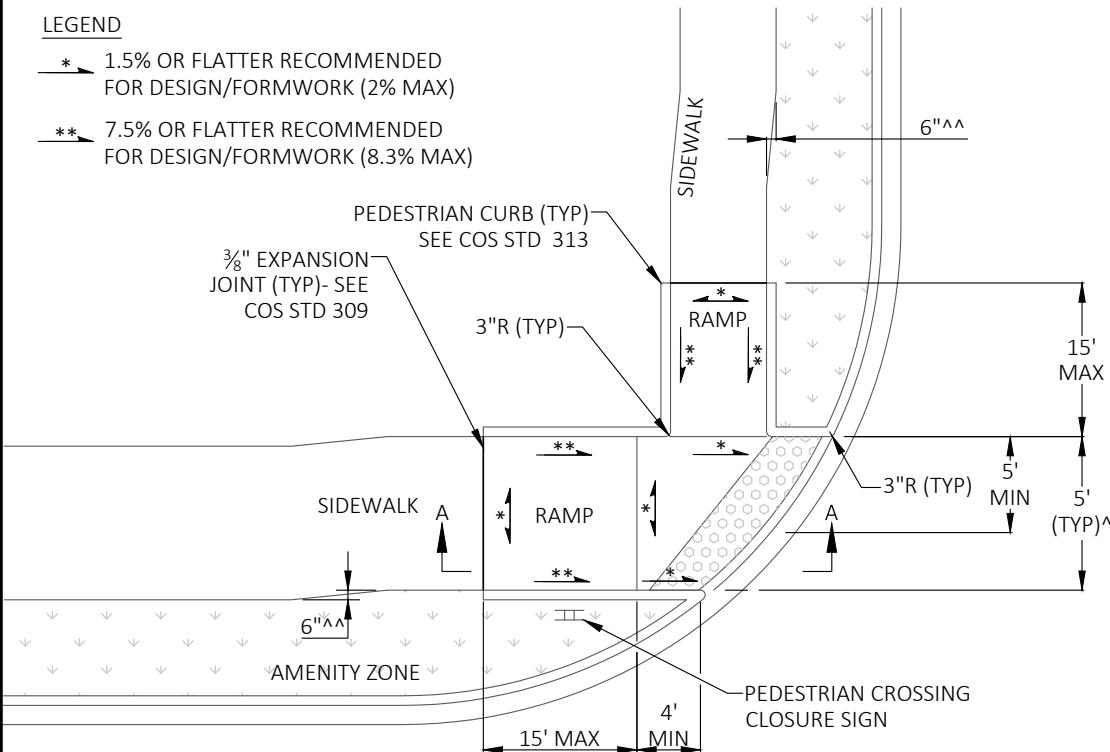

^MATCH SIDEWALK WIDTH WHERE DIRECTED BY THE ENGINEER.

^^RAMP LAYOUT REFLECTS TYPICAL RESIDENTIAL/ ARTERIAL INTERSECTION WHERE THE CROSSWALK ACROSS THE ARTERIAL HAS BEEN CLOSED. CLOSING CROSSWALKS OR MAINTAINING THE CLOSURE OF THE CROSSWALK REQUIRES APPROVAL BY THE CITY TRAFFIC ENGINEER AND APPROVED SIGNAGE.

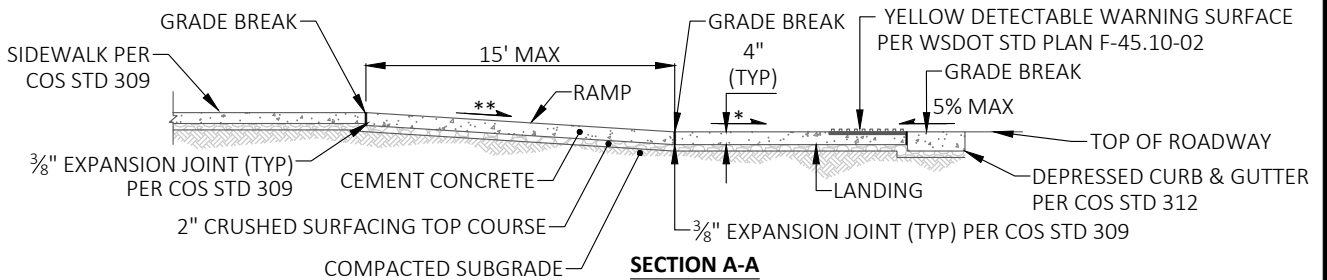

**NOTES:**

1. AT MARKED CROSSWALKS, THE CONNECTION BETWEEN THE LANDING AND THE ROADWAY MUST BE CONTAINED WITHIN THE WIDTH OF THE CROSSWALK MARKINGS.
2. WHERE "GRADE BREAK" IS CALLED OUT, THE ENTIRE LENGTH OF THE GRADE BREAK BETWEEN THE TWO ADJACENT SURFACE PLANES SHALL BE FLUSH.
3. DO NOT PLACE GRATINGS, JUNCTION BOXES, ACCESS COVERS, OR OTHER APPURTENANCES ON ANY PART OF THE CURB RAMP OR LANDING.
4. THE CURB RAMP LENGTH IS NOT REQUIRED TO EXCEED 15 FEET UNLESS SHOWN OTHERWISE IN THE CONTRACT PLANS. WHEN APPLYING THE 15-FOOT MAX LENGTH (MEASURED AT BACK OF SIDEWALK) THE RUNNING SLOPE OF THE CURB RAMP IS ALLOWED TO EXCEED 8.3%. USE A SINGLE CONSTANT SLOPE FROM BOTTOM OF RAMP TO TOP OF RAMP TO MATCH INTO THE SIDEWALK OVER A HORIZONTAL DISTANCE OF 15 FEET.
5. CURB RAMP, LANDING, AND FLARES SHALL RECEIVE BROOM FINISH PER WSDOT STANDARD SPECIFICATIONS 8-14.
6. CURB RAMP SHALL BE ADA COMPLIANT.

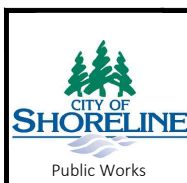

PUBLICATION DATE:	REVISION DATE: <b>09/15/2022</b>
STANDARD DETAIL NUMBER: <b>317</b>	SCALE: <b>NOT TO SCALE</b>

**CURB RAMP - SINGLE DIRECTION**

**LEGEND**

- \* 1.5% OR FLATTER RECOMMENDED FOR DESIGN/FORMWORK (2% MAX)
- \*\* 7.5% OR FLATTER RECOMMENDED FOR DESIGN/FORMWORK (8.3% MAX)
- \*\*\* 9.5% OR FLATTER RECOMMENDED FOR DESIGN/FORMWORK (10% MAX)

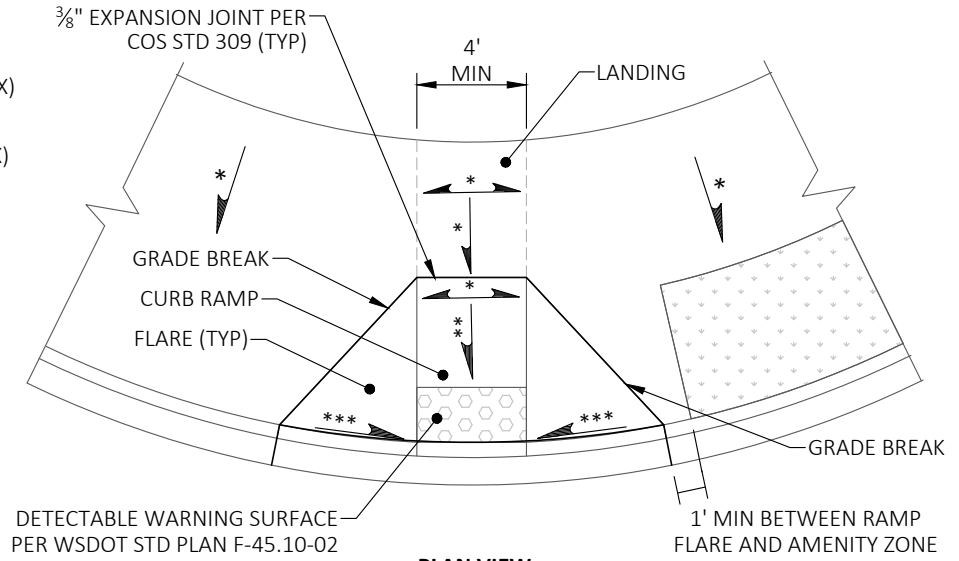

**PLAN VIEW**

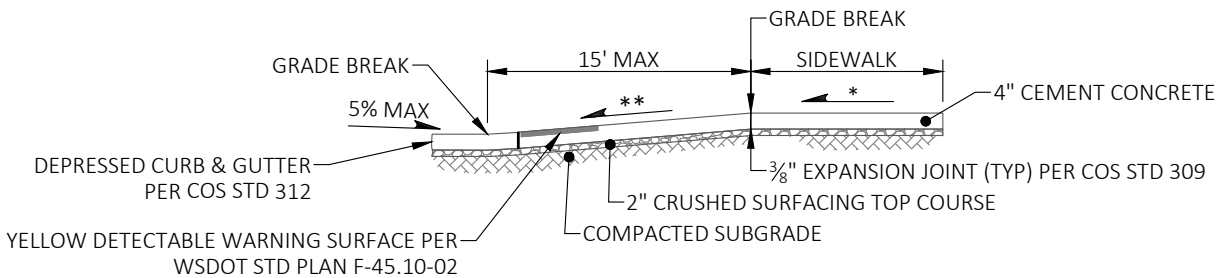

**SECTION VIEW**

**NOTES:**

1. WHERE "GRADE BREAK" IS CALLED OUT, THE ENTIRE LENGTH OF THE GRADE BREAK BETWEEN THE TWO ADJACENT SURFACES SHALL BE FLUSH.
2. DO NOT PLACE GRATINGS, JUNCTION BOXES, ACCESS COVERS, OR OTHER APPURTENANCES ON ANY PART OF THE CURB RAMP OR LANDING, OR IN FRONT OF THE CURB RAMP WHERE IT CONNECTS TO THE ROADWAY.
3. BROOM FINISH PERPENDICULAR TO THE DIRECTION OF PEDESTRIAN TRAVEL.
4. THE CURB RAMP LENGTH IS NOT REQUIRED TO EXCEED 15 FEET UNLESS SHOWN OTHERWISE ON THE CONTRACT PLANS. WHEN APPLYING THE 15-FOOT MAX LENGTH THE RUNNING SLOPE IS ALLOWED TO EXCEED 8.3%. USE A SINGLE CONSTANT SLOPE FROM BOTTOM OF RAMP TO TOP OF RAMP TO MATCH THE LANDING OVER A HORIZONTAL DISTANCE OF 15 FEET. DO NOT INCLUDE THE ABUTTING LANDING IN THE 15-FOOT MAX MEASUREMENT.
5. CURB RAMPS SHALL BE ADA COMPLIANT.
6. RAMP AND LANDING WIDTHS SHALL NOT INCLUDE EXPANSION JOINTS.
7. LANDING WIDTH SHALL MATCH CURB RAMP WIDTH.
8. AT MARKED CROSSWALKS, THE CONNECTION BETWEEN THE LANDING AND THE ROADWAY MUST BE CONTAINED WITHIN THE WIDTH OF THE CROSSWALK MARKINGS.
9. SHARED DIAGONAL PERPENDICULAR RAMPS SHALL NOT BE INSTALLED UNLESS ALL OTHER DESIGN OPTIONS ARE UNABLE TO BE CONSTRUCTED DUE TO SITE CONSTRAINTS.
10. RAMP CENTERLINE SHALL BE RADIAL/PERPENDICULAR TO THE ALIGNMENT OF THE FACE OF CURB.

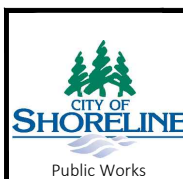

PUBLICATION DATE:	REVISION DATE: <b>09/15/2022</b>
STANDARD DETAIL NUMBER: <b>318</b>	SCALE: <b>NOT TO SCALE</b>

**CURB RAMP - PERPENDICULAR**



**LEGEND**

- \* 1.5% OR FLATTER RECOMMENDED FOR DESIGN/FORMWORK (2% MAX)
- \*\* 7.5% OR FLATTER RECOMMENDED FOR DESIGN/FORMWORK (8.3% MAX)
- \*\*\* 9.5% OR FLATTER RECOMMENDED FOR DESIGN/FORMWORK (10% MAX)

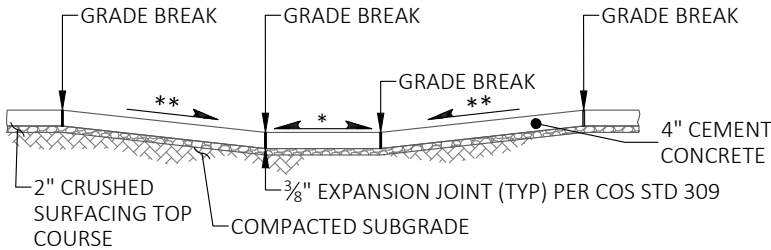
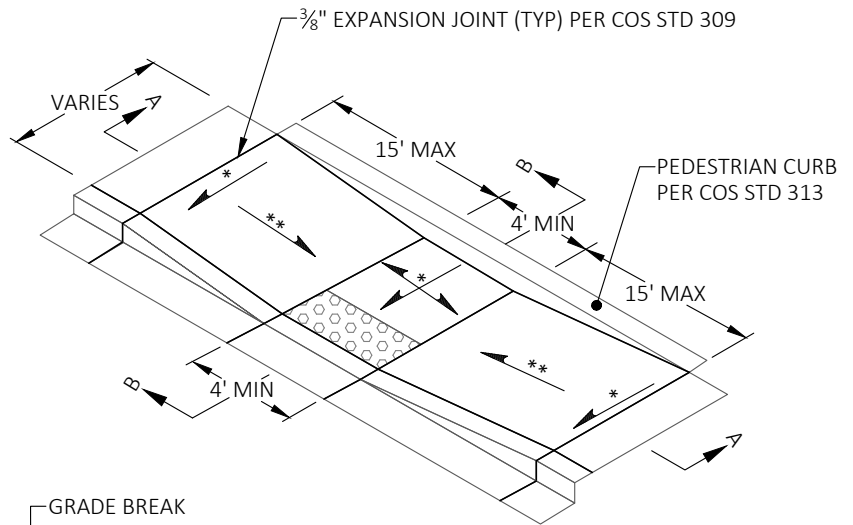

**SECTION A-A**

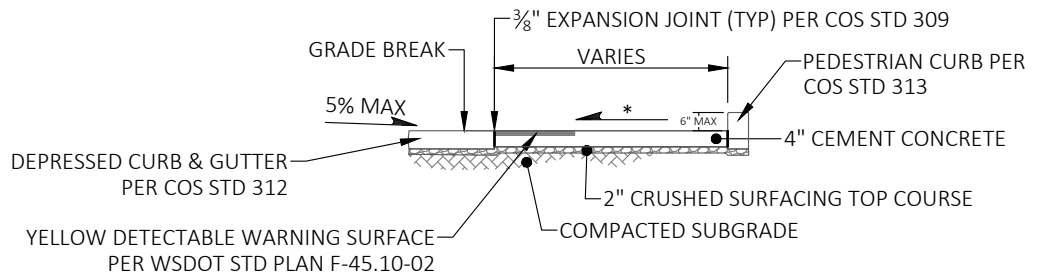

**SECTION B-B**

**NOTES:**

1. WHERE "GRADE BREAK" IS CALLED OUT, THE ENTIRE LENGTH OF THE GRADE BREAK BETWEEN THE TWO ADJACENT SURFACES SHALL BE FLUSH.
2. DO NOT PLACE GRATINGS, JUNCTION BOXES, ACCESS COVERS, OR OTHER APPURTENANCES ON ANY PART OF THE CURB RAMP OR LANDING, OR IN FRONT OF THE CURB RAMP WHERE IT CONNECTS TO THE ROADWAY.
3. BROOM FINISH PERPENDICULAR TO THE DIRECTION OF PEDESTRIAN TRAVEL.
4. THE CURB RAMP LENGTH IS NOT REQUIRED TO EXCEED 15 FEET UNLESS SHOWN OTHERWISE ON THE CONTRACT PLANS. WHEN APPLYING THE 15-FOOT MAX LENGTH THE RUNNING SLOPE IS ALLOWED TO EXCEED 8.3%. USE A SINGLE CONSTANT SLOPE FROM BOTTOM OF RAMP TO TOP OF RAMP TO MATCH THE LANDING OVER A HORIZONTAL DISTANCE OF 15 FEET. DO NOT INCLUDE THE ABUTTING LANDING IN THE 15-FOOT MAX MEASUREMENT.
5. CURB RAMPS SHALL BE ADA COMPLIANT.
6. RAMP AND LANDING WIDTHS SHALL NOT INCLUDE EXPANSION JOINTS.
7. AT MARKED CROSSWALKS, THE CONNECTION BETWEEN THE LANDING AND THE ROADWAY MUST BE CONTAINED WITHIN THE WIDTH OF THE CROSSWALK MARKINGS.
8. BROOM FINISH PERPENDICULAR TO THE DIRECTION OF PEDESTRIAN TRAVEL.

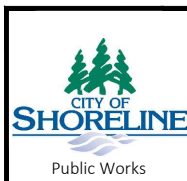

PUBLICATION DATE:	REVISION DATE: <b>09/15/2022</b>
STANDARD DETAIL NUMBER: <b>320</b>	SCALE: <b>NOT TO SCALE</b>

**CURB RAMP - PARALLEL**

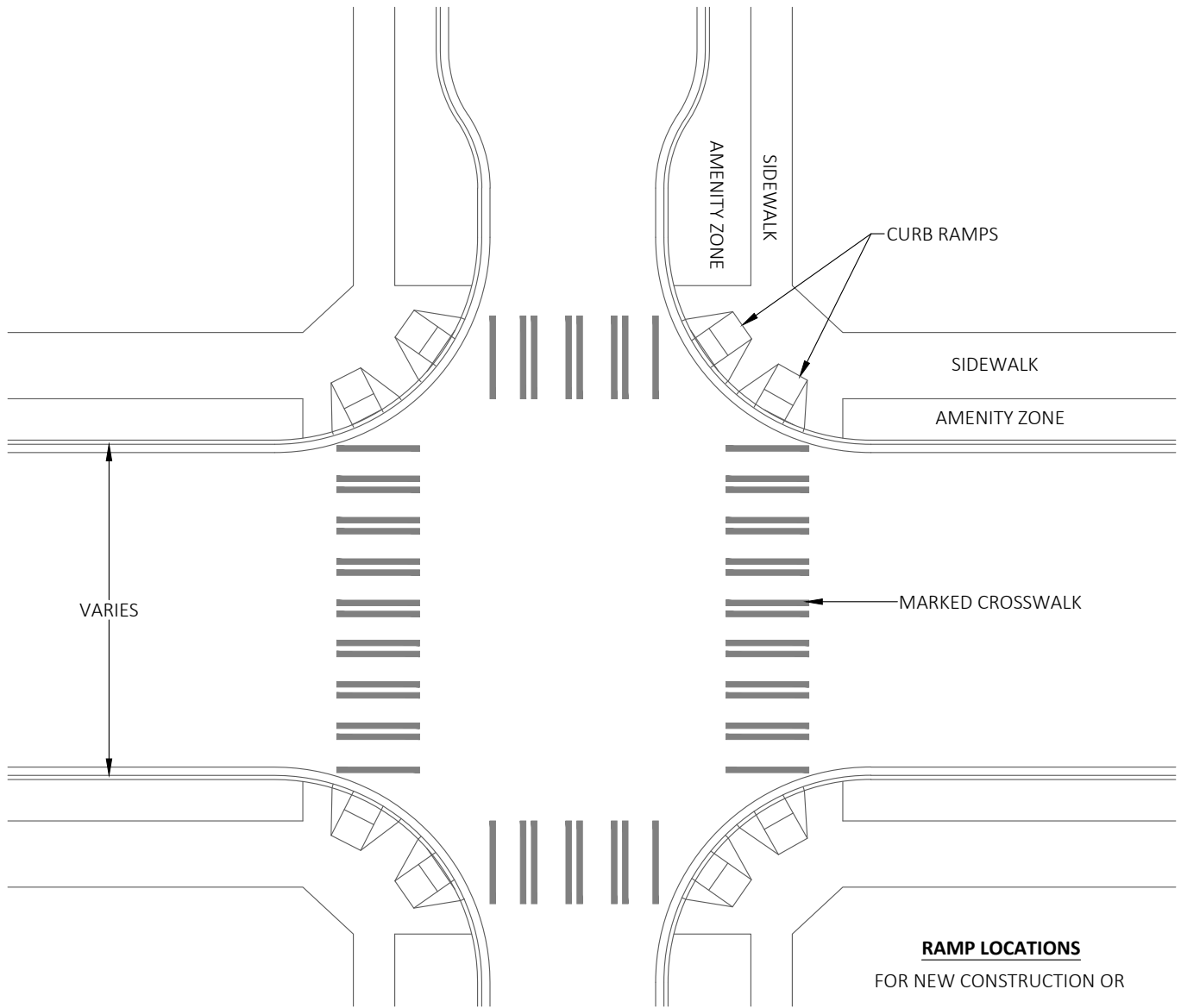

**NOTES:**

1. CURB RAMP CONSTRUCTION MUST COMPLY WITH CURRENT ADA STANDARDS.
2. CONSTRUCT RAMP WITH A MINIMUM 1' CLEARANCE FROM FIXED OBJECTS SUCH AS HYDRANTS, POLES, INLETS, AND OTHER UTILITIES.
3. CONSTRUCT RAMP IN ACCORDANCE WITH COS STD 318 & 320.
4. CROSSWALKS ARE NOT ALWAYS MARKED.
5. WHEN RAMPS ARE CONSTRUCTED ON ONE SIDE OF STREET, COMPANION RAMPS SHALL BE CONSTRUCTED AT CORRESPONDING LOCATIONS ON OPPOSITE SIDE OF STREET.

	PUBLICATION DATE:	REVISION DATE: <b>02/11/2020</b>
	STANDARD DETAIL NUMBER: <b>321</b>	SCALE: <b>NOT TO SCALE</b>
<b>CURB RAMP LOCATIONS</b>		

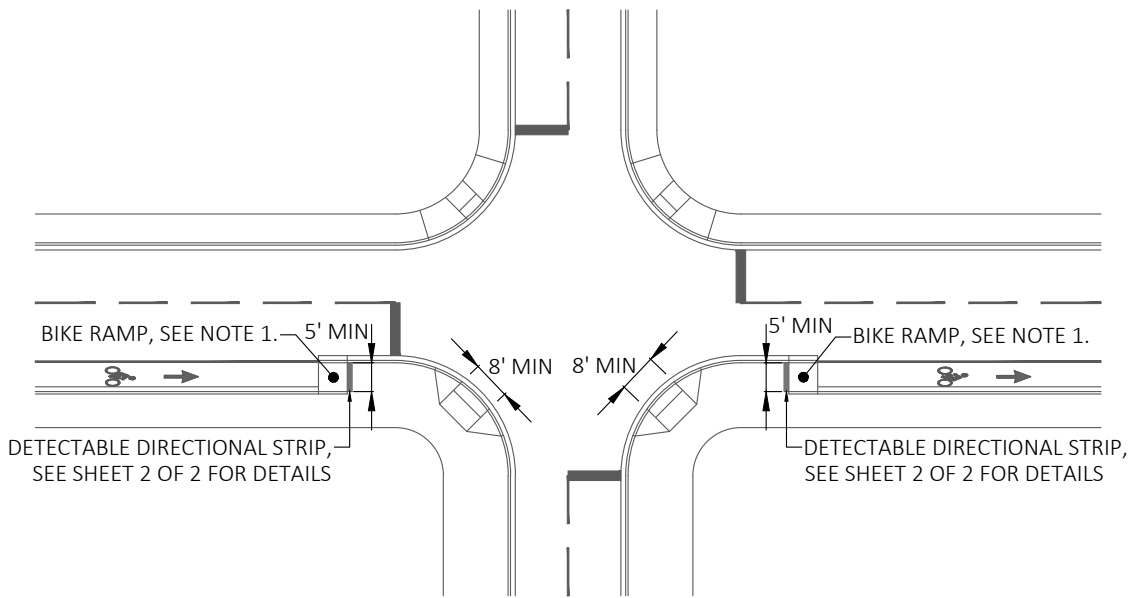

**BIKE RAMP TO/FROM SIDEWALK GRADE WITHOUT AMENITY ZONE**

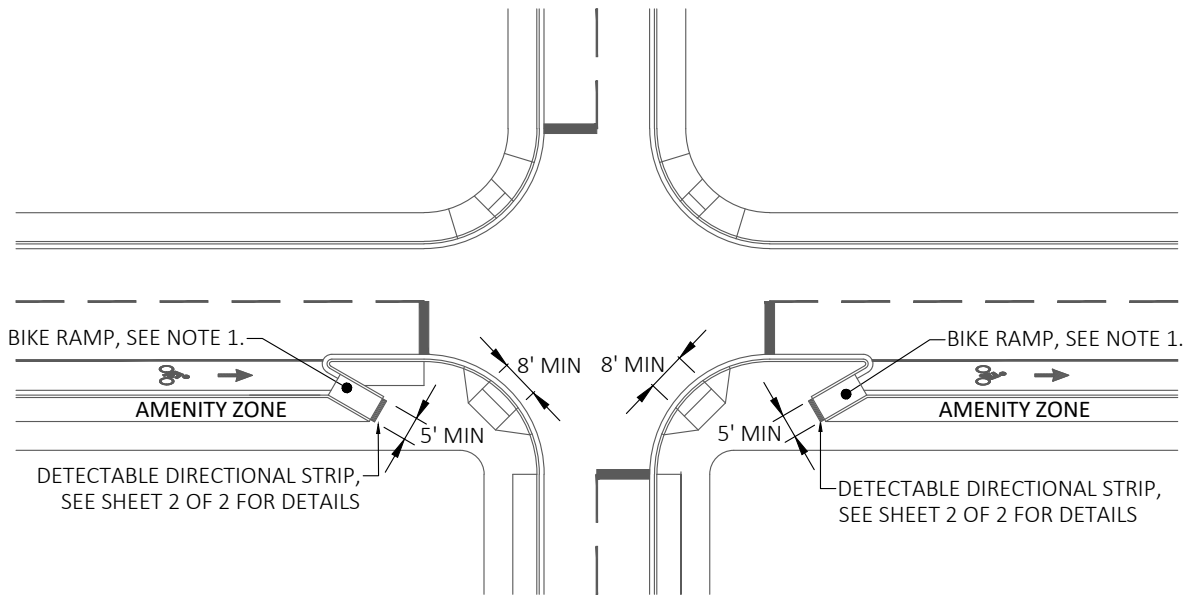

**BIKE RAMP TO/FROM SIDEWALK GRADE WITH AMENITY ZONE**

**NOTES:**

1. 10 % MAXIMUM SLOPE. SEE CITY OF SHORELINE CURB RAMP DETAILS FOR MORE INFORMATION.
2. CONCRETE SHALL BE AIR ENTRAINED CLASS 3000 PER WSDOT STANDARD SPECIFICATIONS 6-02.
3. WHEN BIKE AND PEDESTRIAN FACILITIES ARE COMBINED, CURB RAMP SHALL HAVE A MINIMUM 8' WIDTH.

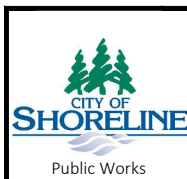

PUBLICATION DATE:	REVISION DATE: <b>08/23/2023</b>
STANDARD DETAIL NUMBER: <b>322</b>	SCALE: <b>NOT TO SCALE</b>

**BIKE RAMP 1 OF 2**

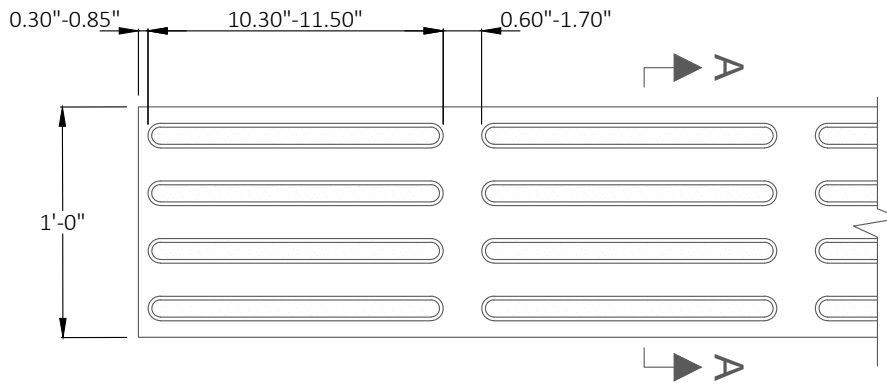

**DETECTABLE DIRECTIONAL STRIP - CAST-IN-PLACE**  
 \*CAST IN PLACE STRIP IS PREFERRED

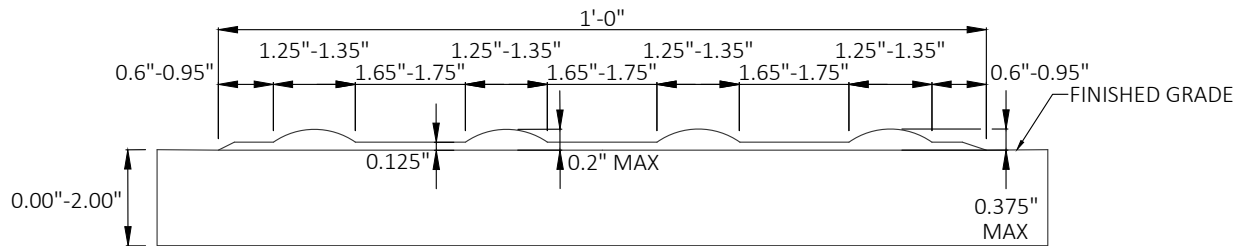

**SECTION A-A**

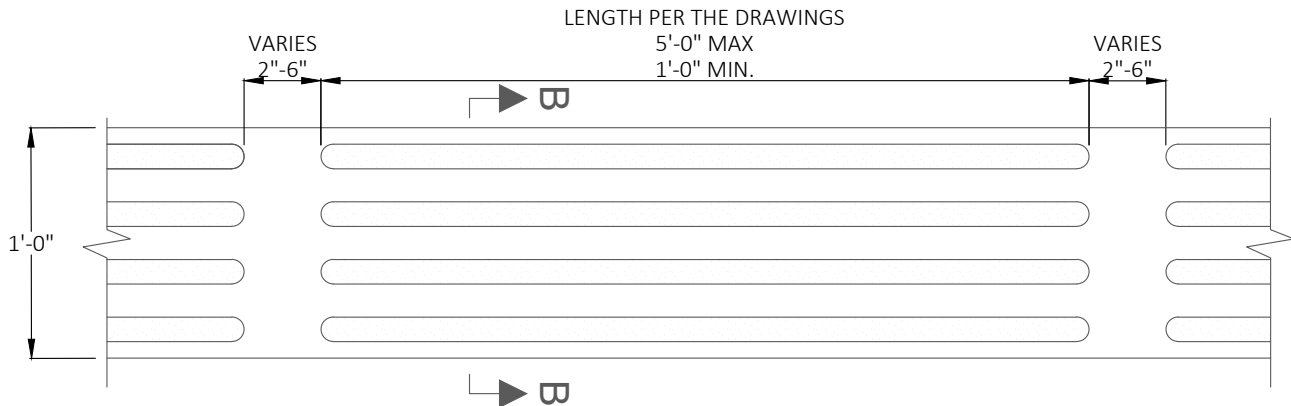

**DETECTABLE DIRECTIONAL STRIP - SURFACE APPLIED MMA**  
 \*MMA STRIP ONLY ALLOWED WHEN RETROFITTING EXISTING RAMP

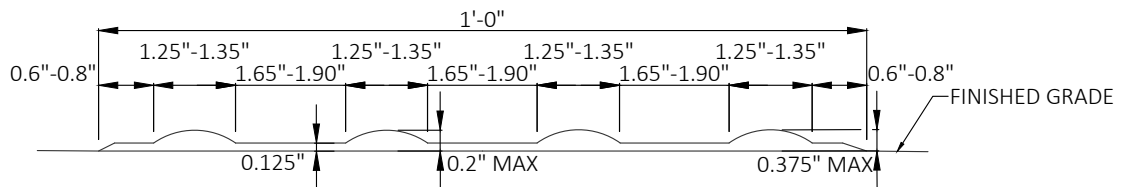

**SECTION B-B**

**NOTES:**

1. DETECTABLE DIRECTIONAL STRIP MUST BE "FEDERAL YELLOW," UNLESS OTHERWISE APPROVED BY THE ENGINEER.
2. METHYL METHACRYLATE (MMA) DIRECTIONAL STRIP MUST COMPLY WITH ALL THE DIMENSION RANGES SHOWN ON THIS STANDARD PLAN OR IT MAY BE DEEMED DEFECTIVE AND SUBJECT TO REMOVAL AND REPLACEMENT.
3. DIRECTIONAL STRIP MAY BE BOLTED DOWN IF APPROVED BY THE ENGINEER.



PUBLICATION DATE:	REVISION DATE: <b>08/23/2023</b>
STANDARD DETAIL NUMBER: <b>322</b>	SCALE: <b>NOT TO SCALE</b>

**BIKE RAMP 2 OF 2**

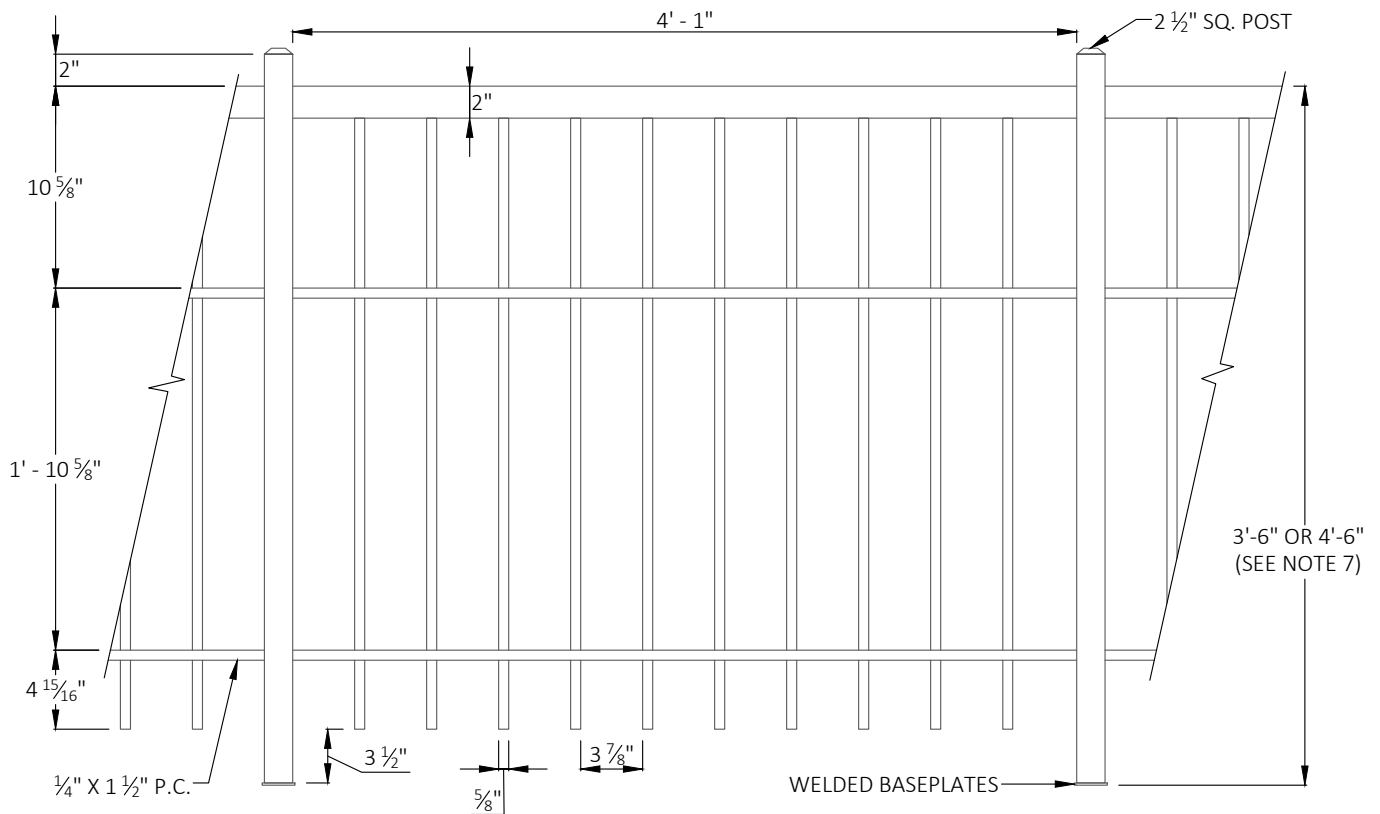

**NOTES:**

1. SHOP DRAWINGS OF RAILING SHALL BE SUBMITTED FOR APPROVAL SHOWING COMPLETE DIMENSIONS AND DETAILS OF FABRICATION AND INCLUDING AN ERECTION DIAGRAM. MATERIALS BEING USED SHALL BE SPECIFIED IN THE SHOP DRAWINGS.
2. ALL ALUMINUM PARTS SHALL BE GIVEN A BLACK ANODIC COATING AT LEAST 0.0006 INCH THICK AND BE HOT WATER SEALED AND SHALL HAVE A UNIFORM FINISH.
3. CUTTING SHALL BE DONE BY SAWING OR MILLING AND ALL CUTS SHALL BE TRUE AND SMOOTH. FLAME CUTTING WILL NOT BE PERMITTED.
4. PIPE RAILING, PIPE BALUSTERS AND PIPE RAILING SPLICES SHALL BE ADEQUATELY WRAPPED TO ENSURE SURFACE PROTECTION DURING HANDLING AND TRANSPORTATION TO THE JOB SITE.
5. WELDING OF ALUMINUM SHALL BE IN ACCORDANCE WITH THE LATEST AASHTO STANDARD SPECIFICATIONS FOR STRUCTURAL SUPPORTS FOR HIGHWAY SIGNS, LUMINAIRES AND TRAFFIC SIGNALS.
6. ALLOW FOR EXPANSION AT APPROXIMATELY EVERY FOURTH POST.
7. TOP OF RAIL:
  - 3 FEET 6 INCHES FOR PEDESTRIAN USES
  - 4 FEET 6 INCHES FOR COMBINED BICYCLE AND PEDESTRIAN USES
8. 50LB RAIL LOADING PER IBC, CURRENT EDITION.
9. ALL CONCEALED FASTENERS THROUGHOUT.

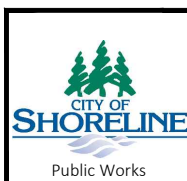

PUBLICATION DATE:	REVISION DATE: <b>09/15/2022</b>
STANDARD DETAIL NUMBER: <b>324</b>	SCALE: <b>NOT TO SCALE</b>

**PEDESTRIAN RAILING**

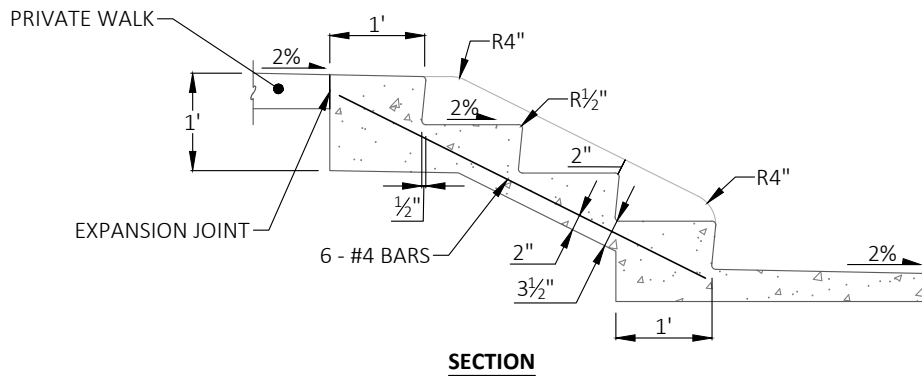
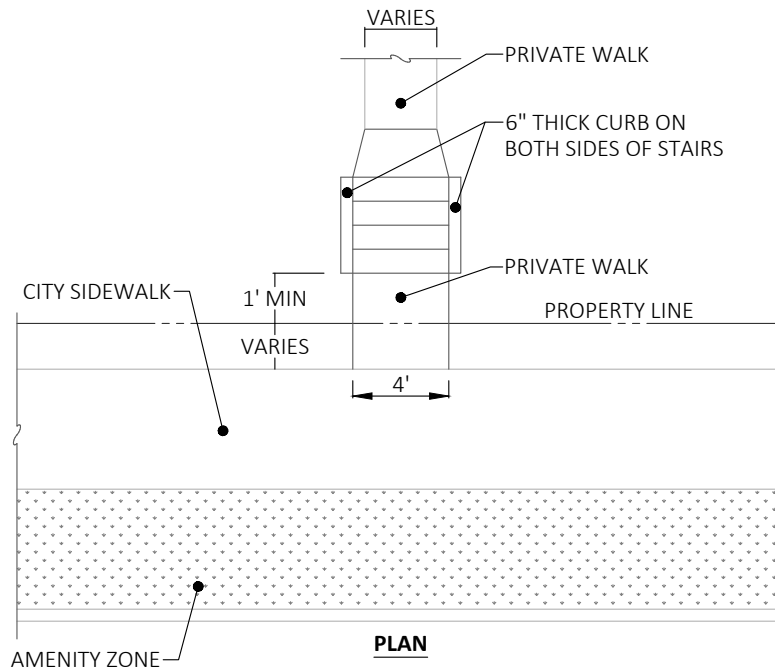

**NOTES:**

1. STEPS SHALL BE A MINIMUM OF 4'-0" WIDE, CURB TO CURB, PLUS 6" CURBS ON EACH SIDE.
2. CEMENT CONCRETE SHALL BE CLASS 4000psi TROWEL FINISH.
3. NUMBER OF STEPS SHALL SUIT INDIVIDUAL CONDITIONS, WITH TREAD AND RISER DIMENSIONS TO SUIT THE GRADE.
4. RISERS SHALL BE 5" MINIMUM, 7" MAXIMUM: TREAD SHALL BE 11" MINIMUM, 12" MAXIMUM.
5. HANDRAIL REQUIRED ON BOTH SIDES PER IBC.
6. ALL STEPS SHALL BE UNIFORM HEIGHT & DEPTH.

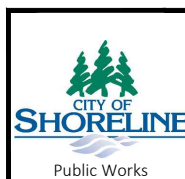

PUBLICATION DATE:

REVISION DATE: **02/11/2020**

STANDARD DETAIL NUMBER: **325**

SCALE: **NOT TO SCALE**

**STAIRS**

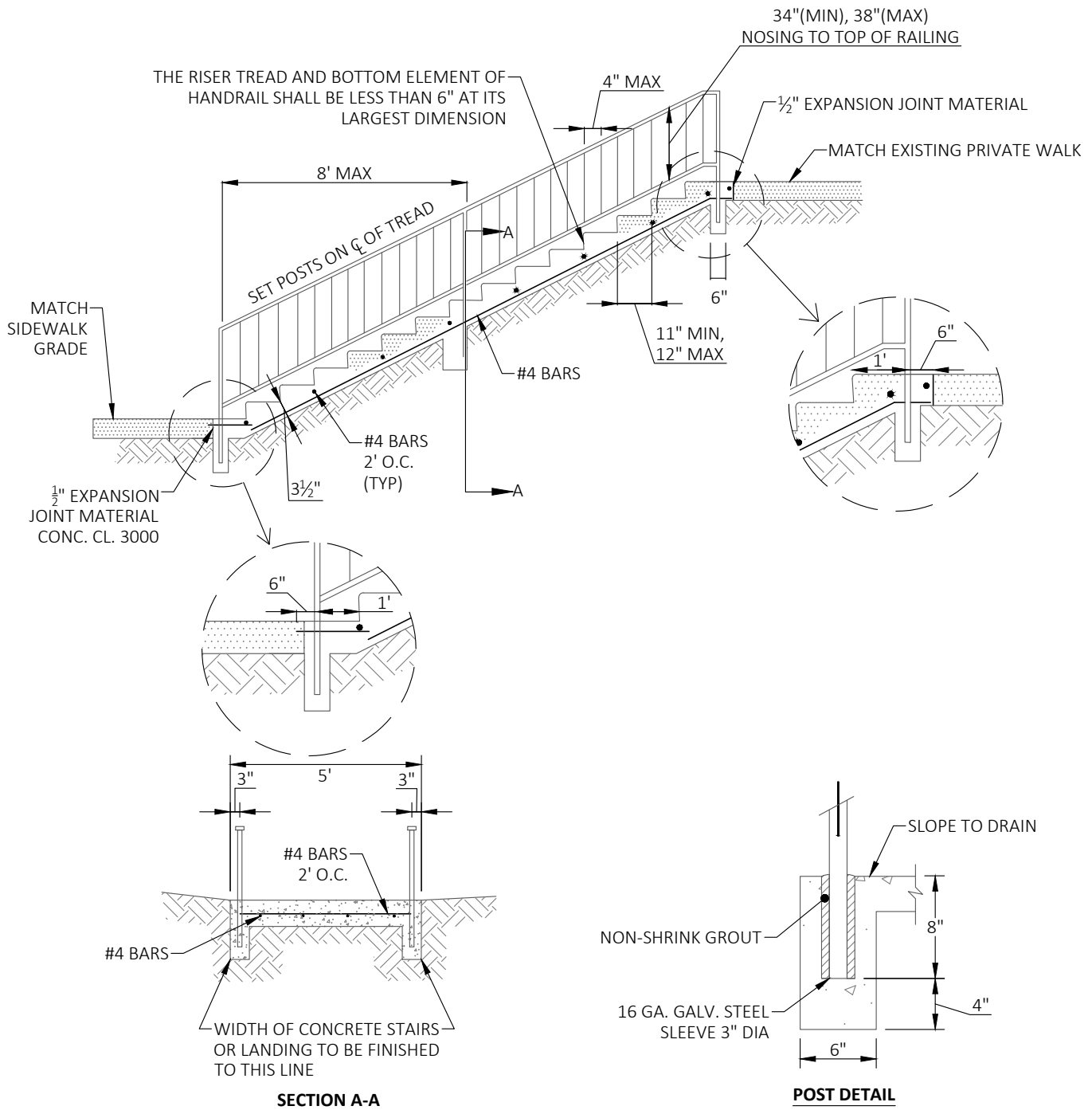

**NOTES:**

1. CEMENT CONCRETE STEPS AND CURBS SHALL BE CONSTRUCTED AS SHOWN ON COS STD 325.
2. HEIGHT OF RAILING SHALL BE 36" MINIMUM, 38" MAXIMUM TOP OF NOSING TO TOP OF RAILING.
3. PEDESTRIAN RAILING SHALL BE CONSTRUCTED AS SHOWN ON COS STD 324.
4. CLEAR SPACE BETWEEN BALUSTERS SHALL BE A MAXIMUM OF 4".
5. ALL STEPS SHALL HAVE HANDRAIL ON BOTH SIDES.

 CITY OF SHORELINE Public Works	PUBLICATION DATE:	REVISION DATE: <b>02/11/2020</b>
	STANDARD DETAIL NUMBER: <b>326</b>	SCALE: <b>NOT TO SCALE</b>
<b>CEMENT CONCRETE STAIRWAY</b>		

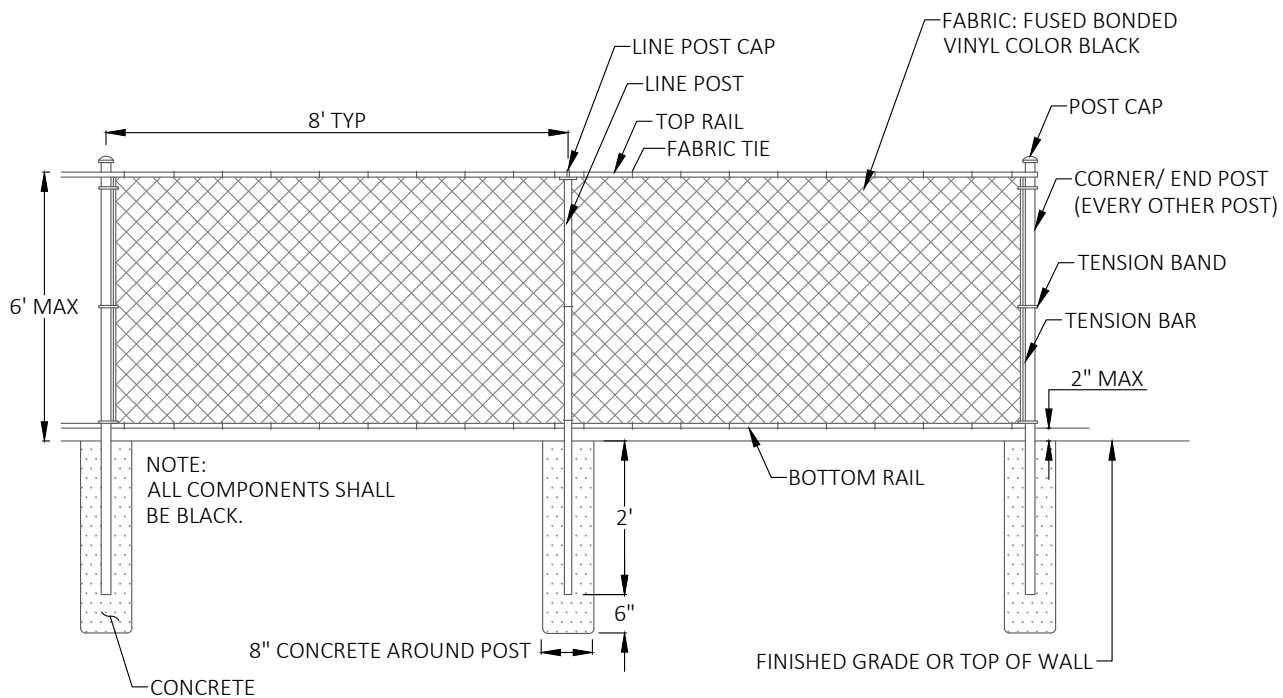

**PIPE SCHEDULE**  
(ALL DIMENSION I.D.)

TOP/BOTTOM RAIL	CORNER/ END POST	LINE POST
1.25"	2.5"	2"

**NOTES:**

1. RAILING SHALL BE ALUMINUM PIPE RAIL OR APPROVED EQUIVALENT. INSTALLATION PER MANUFACTURER'S RECOMMENDATIONS.
2. SHOP DRAWINGS OF RAILING SHALL BE SUBMITTED FOR APPROVAL SHOWING COMPLETE DIMENSIONS AND DETAILS OF FABRICATION AND INCLUDING AN ERECTION DIAGRAM. MATERIALS BEING USED SHALL BE SPECIFIED IN THE SHOP DRAWINGS.
3. ALL ALUMINUM PARTS SHALL BE GIVEN A BLACK ANODIC COATING AT LEAST 0.0006 INCH THICK AND BE HOT WATER SEALED AND SHALL HAVE A UNIFORM FINISH.
4. WIRE FABRIC SHALL BE GIVEN A BLACK FUSED BONDED VINYL COATING TO MATCH FINISHED POSTS.
5. CUTTING SHALL BE DONE BY SAWING OR MILLING AND ALL CUTS SHALL BE TRUE AND SMOOTH. FLAME CUTTING WILL NOT BE PERMITTED.
6. ALL MATERIALS SHALL BE ADEQUATELY WRAPPED TO ENSURE SURFACE PROTECTION DURING HANDLING AND TRANSPORTATION TO THE JOB SITE.
7. ANY WELDING OF ALUMINUM SHALL BE IN ACCORDANCE WITH THE LATEST AASHTO STANDARD SPECIFICATIONS FOR STRUCTURAL SUPPORTS FOR HIGHWAY SIGNS, LUMINAIRES AND TRAFFIC SIGNALS.
8. RAILS, POSTS AND FORMED ELBOWS SHALL BE A.S.T.M B-241 OR B-429 ALLOY, 6063-T6 SCHEDULE 40 (STD. PIPE). BRACKETS, ENDCAPS AND OTHER FITTINGS SHALL BE A.S.T.M. 6063-T5. SPLICES AND REINFORCING SLEEVES SHALL BE DRAWN ALUMINUM TUBING 6063-T832.
9. TOP OF RAIL: 3 FEET 6 INCHES MIN FOR PEDESTRIAN USES/ 4 FEET 6 INCHES MIN FOR COMBINED BICYCLE AND PEDESTRIAN USES

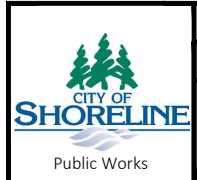

PUBLICATION DATE:	REVISION DATE: <b>02/11/2020</b>
STANDARD DETAIL NUMBER: <b>327</b>	SCALE: <b>NOT TO SCALE</b>

**CHAIN LINK FENCING**



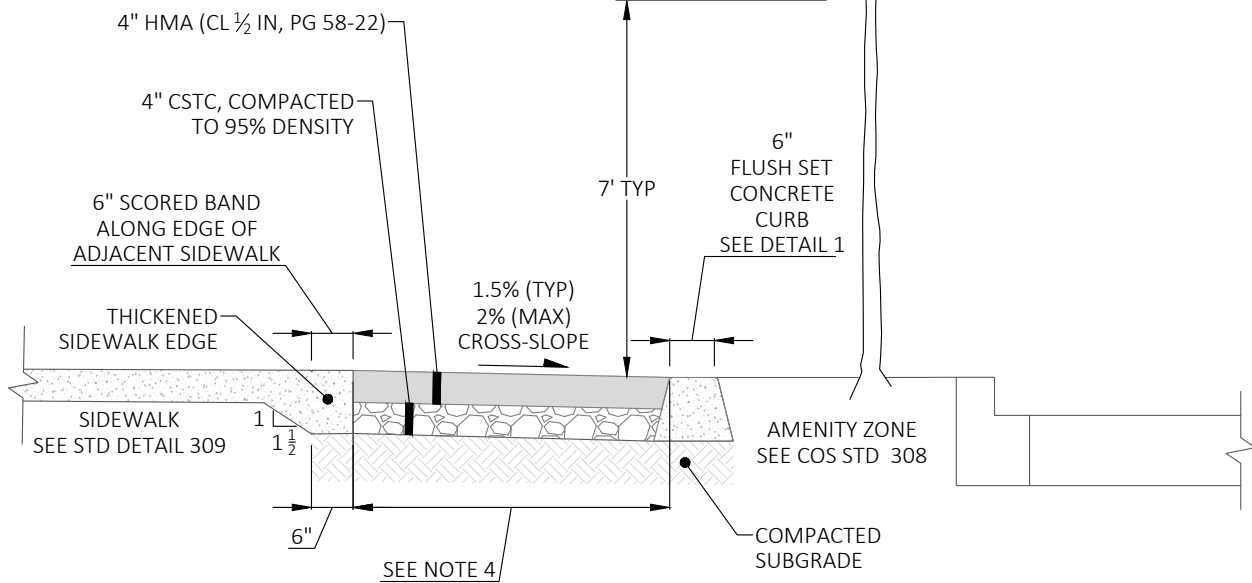
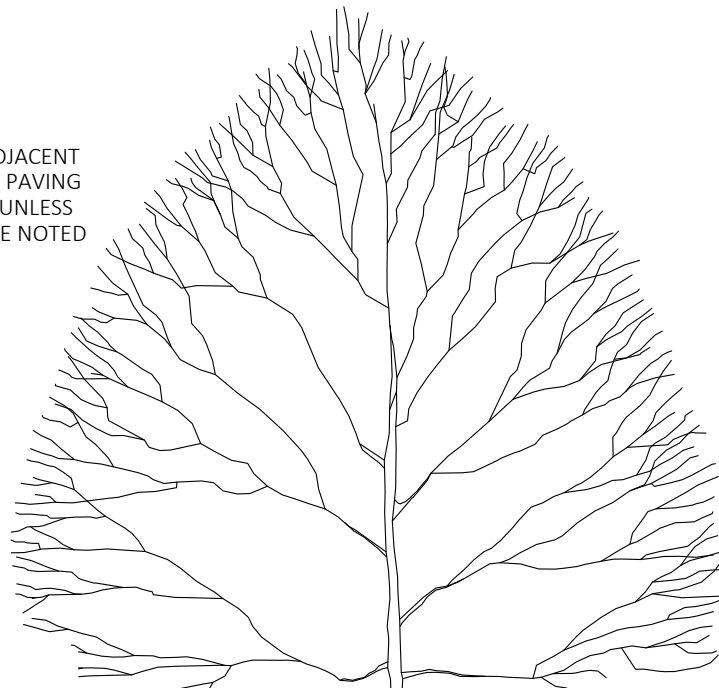
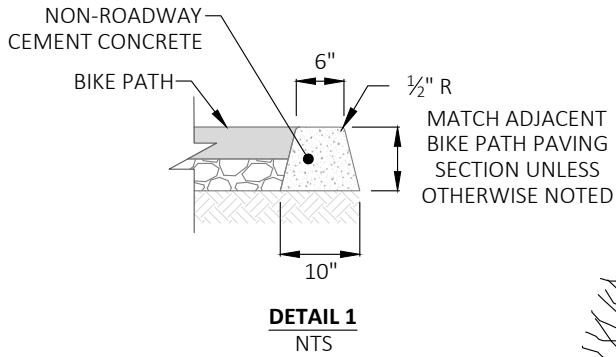

**LEGEND**

- ASPHALT
- CONCRETE
- CSTC
- SUBGRADE

**NOTES:**

1. ALL PLANS MUST BE APPROVED BY THE CITY PRIOR TO CONSTRUCTION OF THE BIKE PATH. BIKE PATH CENTERLINE SHALL BE STAKED IN FIELD BY CONTRACTOR AND APPROVED BY THE CITY INSPECTOR.
2. MINIMUM BRANCH CLEARANCE ABOVE PATH SURFACE = 7'-0" (TYPICAL).
3. SEE BIKE LANE MARKINGS COS STD 410.
4. BIKE PATH WIDTH PER SECTION 14.3 OF THE EDM.

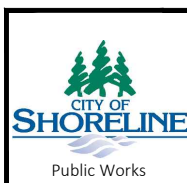

PUBLICATION DATE:	REVISION DATE: <b>10/06/2021</b>
STANDARD DETAIL NUMBER: <b>328</b>	SCALE: <b>NOT TO SCALE</b>

**OFF-STREET BIKE PATH**

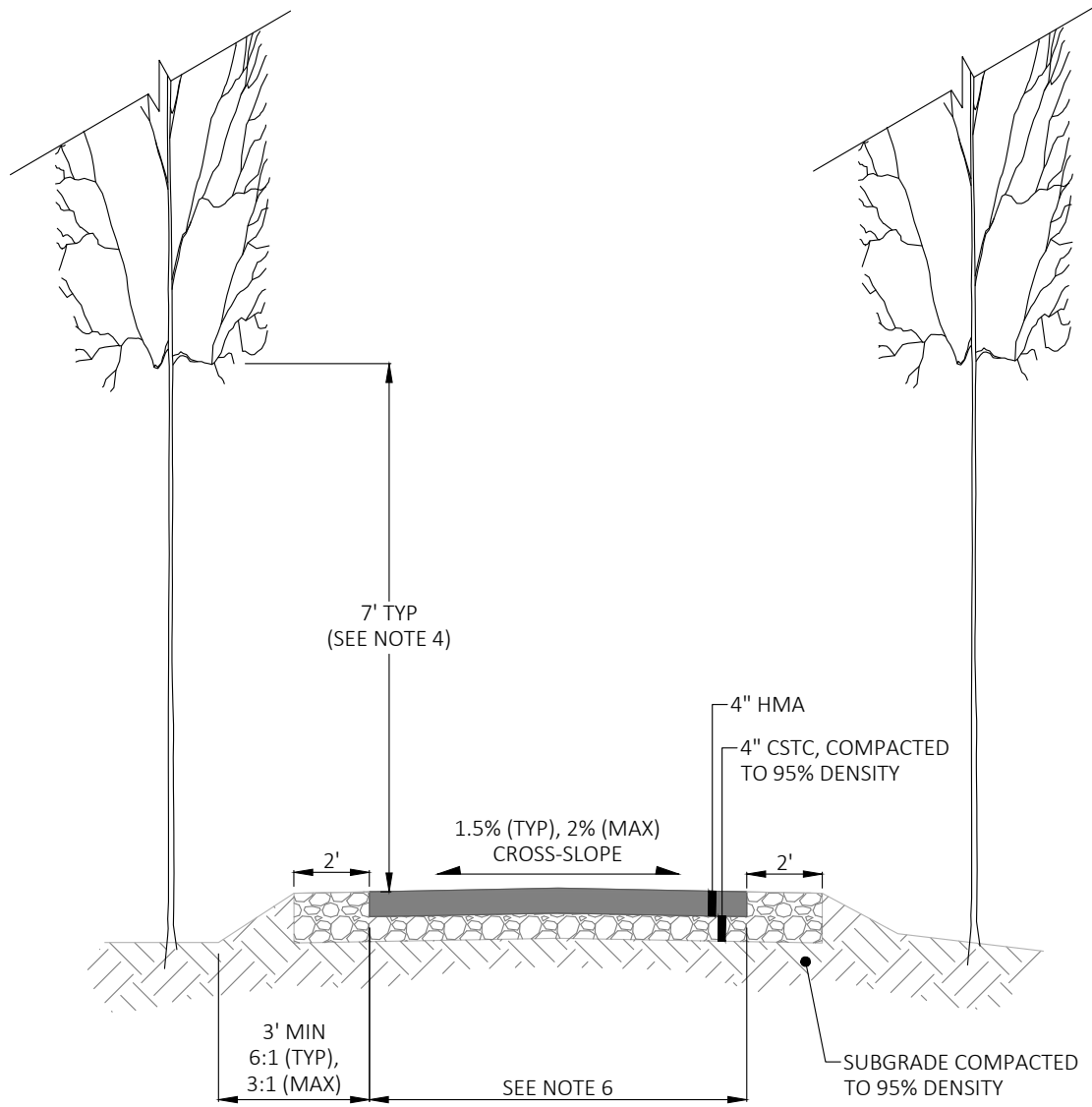

**NOTES:**

1. ALL PLANS MUST BE APPROVED BY THE CITY PRIOR TO CONSTRUCTION OF THE TRAIL. TRAIL CENTERLINE TO BE STAKED IN FIELD BY CONTRACTOR AND APPROVED BY THE CITY INSPECTOR.
2. ALL HAZARD TREES AND TREE LIMBS, AS DEFINED BY THE WASHINGTON STATE DEPARTMENT OF NATURAL RESOURCES HAZARD TREE BULLETIN, SHALL BE FELLED AND REMOVED FROM THE SITE.
3. SUBGRADE TO BE TREATED WITH AN APPROVED HERBICIDE PRIOR TO PLACING ASPHALT.
4. MINIMUM BRANCH CLEARANCE ABOVE TRAIL SURFACE = 7'.
5. ANY TRAILS USED FOR MAINTENANCE, 8' MIN. WIDTH.
6. WIDTH PER SECTION 14.3 OF THE EDM.

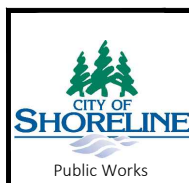

PUBLICATION DATE:

REVISION DATE: **02/10/2021**

STANDARD DETAIL NUMBER: **329**

SCALE: **NOT TO SCALE**

**TYPICAL TRAIL SECTION**

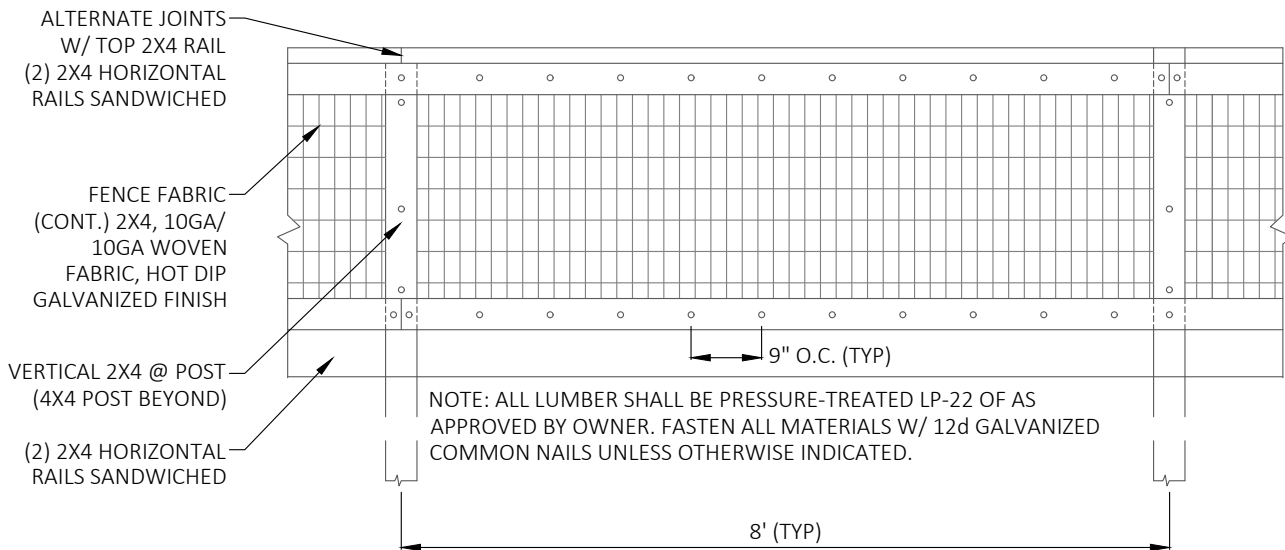

**ELEVATION**

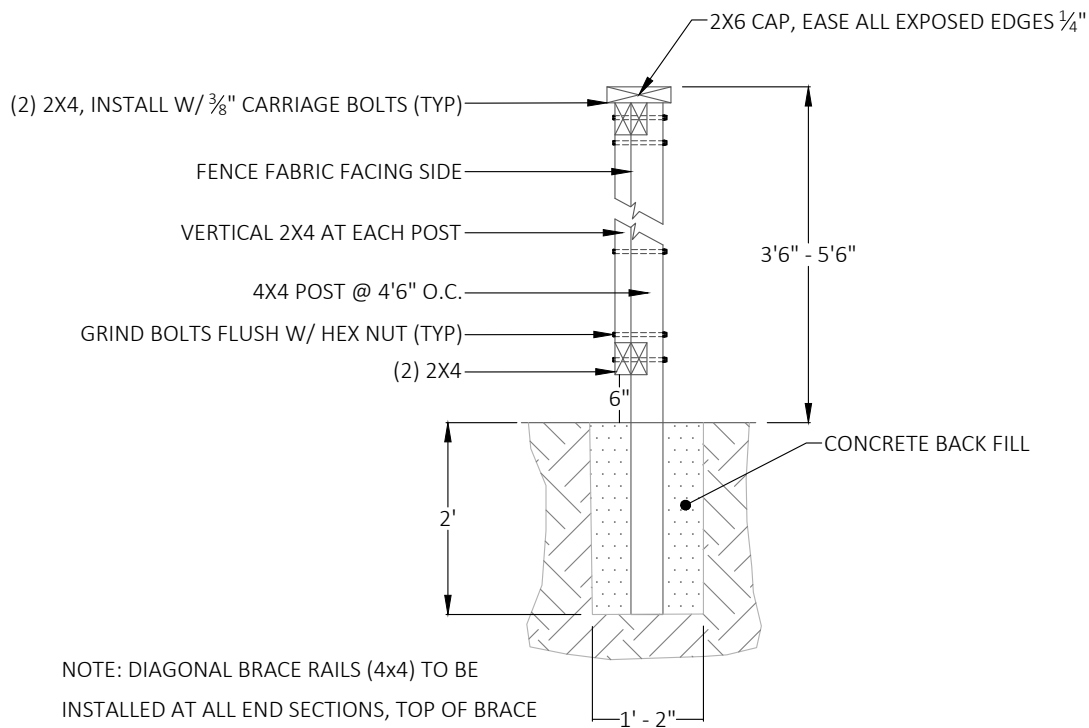

**SECTION**

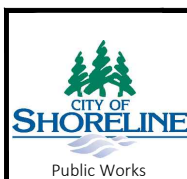

PUBLICATION DATE:

REVISION DATE: **02/11/2020**

STANDARD DETAIL NUMBER: **335**

SCALE: **NOT TO SCALE**

**GREENBELT FENCE**