

NOTES:
1. MATERIAL - WSDOT CONCRETE CLASS 4000psi.

PLAN VIEW

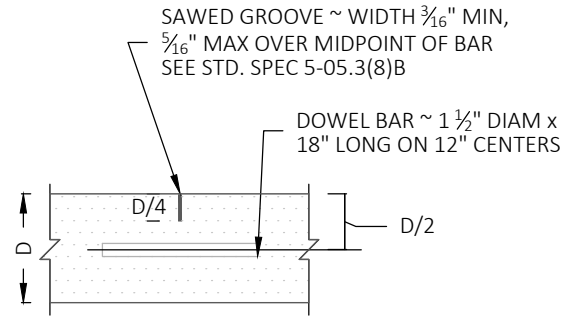

SECTION VIEW TRAVERSE CONTRACTION JOINT

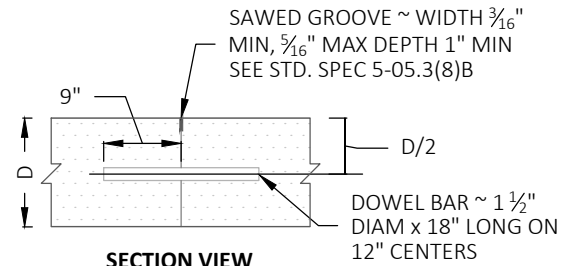

SECTION VIEW TRAVERSE CONSTRUCTION JOINT

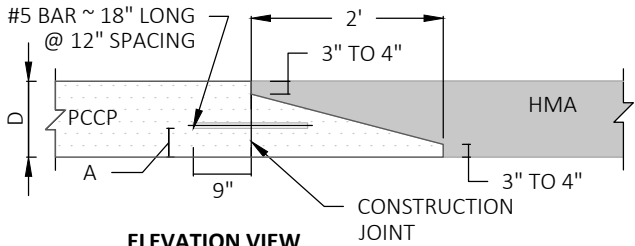

ELEVATION VIEW HMA TRANSITION DETAIL

SLAB THICKNESS (D)	A
12"	5"
D	D/2 - 1"

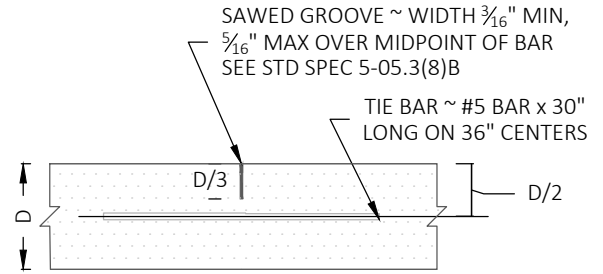

SECTION VIEW LONGITUDINAL CONTRACTION JOINT

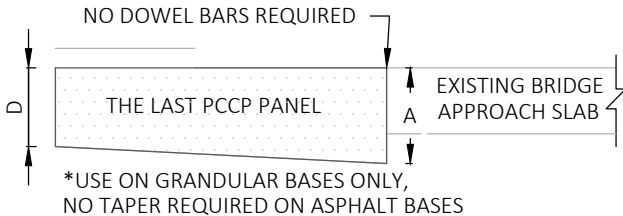

ELEVATION VIEW EXISTING APPROACH SLAB TRANSITION DETAIL

SLAB THICKNESS (D)	A
12"	15"
D	1.25" - D

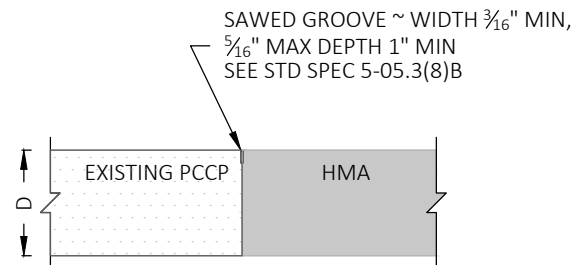

SECTION VIEW PCCP TO HMA LONGITUDINAL JOINT

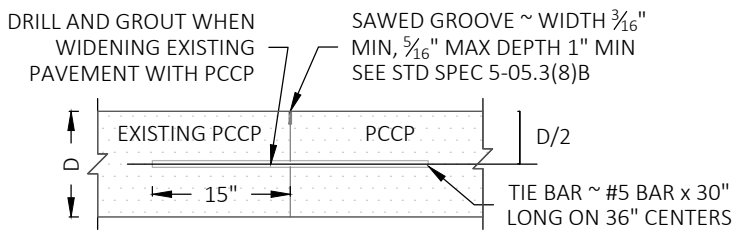

SECTION VIEW PCCP TO PCCP LONGITUDINAL CONTRACTION JOINT

Tricia Juhnke

APPROVED BY: TRICIA JUHNKE
CITY ENGINEER



STANDARD DETAIL NUMBER: **801** SCALE: **NOT TO SCALE**

RIGID PAVEMENT RESTORATION DETAIL

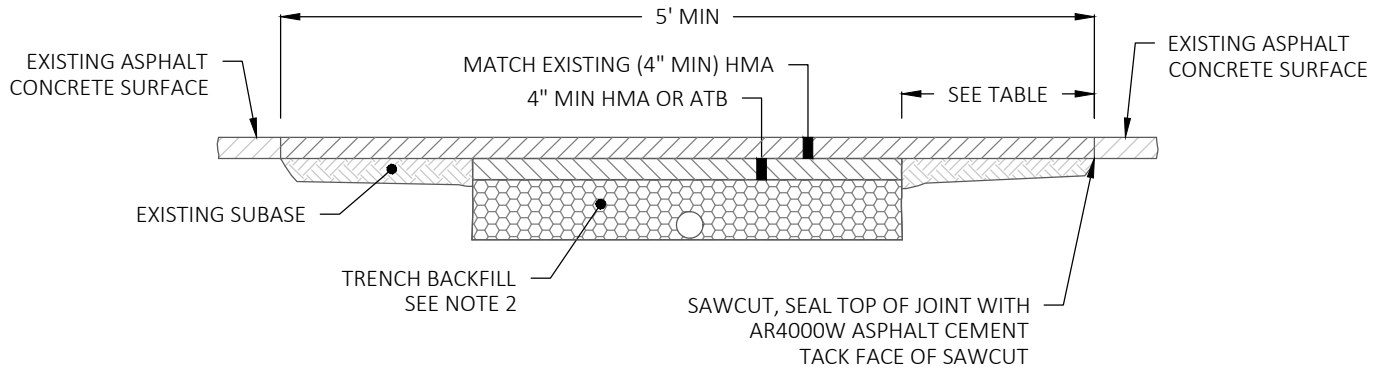

PAVEMENT CUT DIMENSIONS	
TRENCH DEPTH (FT)	MINIMUM CUT BEYOND TRENCH (FT) ALL FOUR SIDES
UP TO 4	1.0
MORE THAN 4 UP TO 6	1.5
MORE THAN 6 UP TO 8	2.0
10	2.5
12	3.0
14	3.5
16	4.0
18	4.5
20	5.0
PAVEMENT LESS THAN 5 YEARS OLD	10.0

NOTES:

1. ASPHALT CONCRETE MIX SHALL BE HMA.
2. ALL TRENCH BACKFILL SHALL BE CRUSHED SURFACING COURSE MATERIAL COMPACTED AT 95%. CDF MAY BE USED AS AN ALTERNATIVE.
3. SAWCUT LIMITS MAY BE REVISED BASED UPON EXISTING CONDITIONS. PATCH MAY NEED TO EXTEND TO CONFIDENT ASPHALT.
4. SAWCUTS NEED TO BE NEAT AND CLEAN PRIOR TO PAVING.

Tricia Juhnke

APPROVED BY: TRICIA JUHNKE
CITY ENGINEER



STANDARD DETAIL NUMBER: **802** SCALE: **NOT TO SCALE**

FLEXIBLE PAVEMENT PATCHING

PUBLICATION DATE: 3/1/2021 REVISION DATE: 2/11/2020