

**NOTES**

1. The culvert ends shall be beveled to match the embankment or ditch slope and shall not be beveled flatter than 4H:1V. When slopes are between 4H:1V and 6H:1V, shape the slope in the vicinity of the culvert end to ensure that no part of the culvert protrudes more than 4" above the ground line.
2. Field cutting of culvert ends is permitted when approved by the Engineer. All field-cut culvert pipe shall be treated with treatment as shown in the Standard Specifications or General Special Provisions.

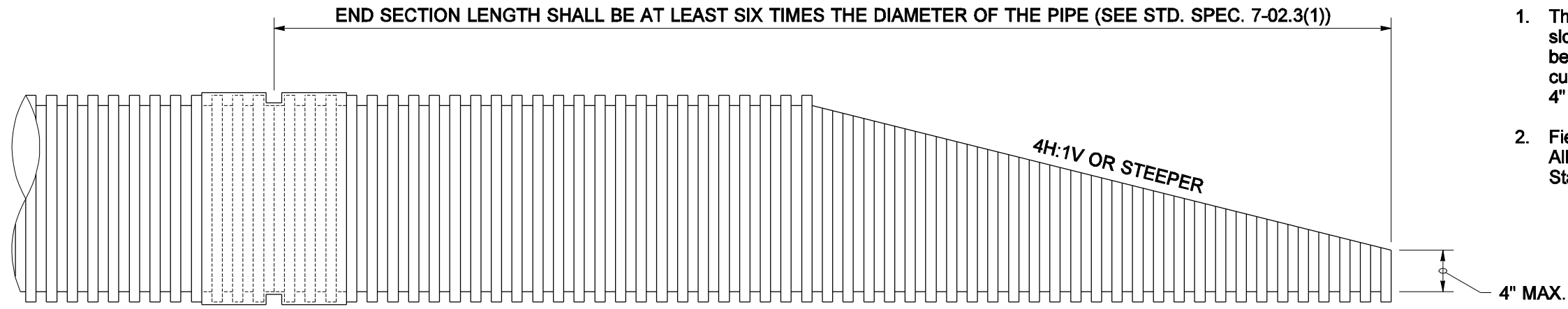

**THERMOPLASTIC PIPE**

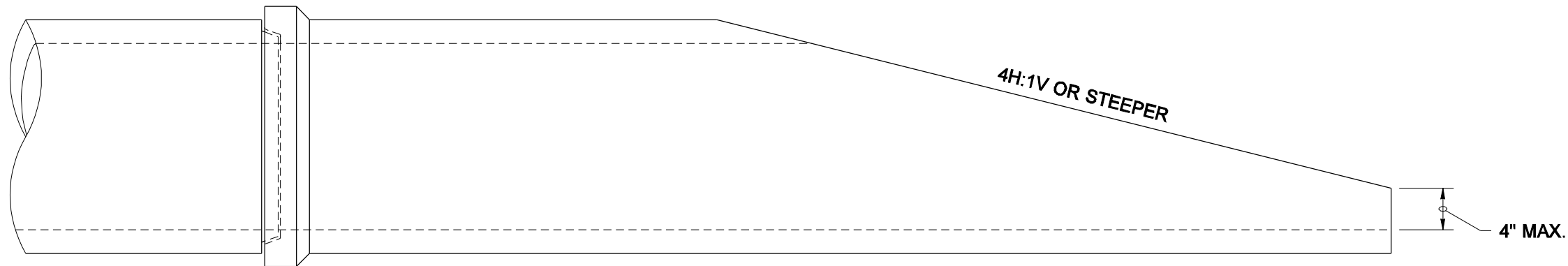

**CONCRETE PIPE**

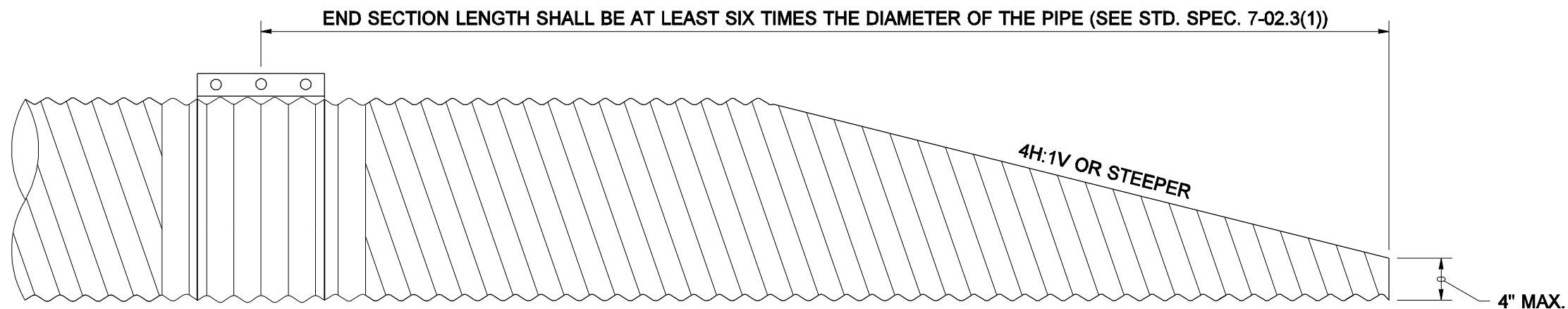

**METAL PIPE**

**FOR CULVERTS 30" DIAMETER OR LESS**



EXPIRES JULY 1, 2007

NOTE: THIS PLAN IS NOT A LEGAL ENGINEERING DOCUMENT UNTIL AN ELECTRONIC OR PLATE. THE ORIGINAL, SIGNED BY THE ENGINEER AND APPROVED FOR PUBLICATION, IS KEPT ON FILE AT THE WASHINGTON STATE DEPARTMENT OF TRANSPORTATION. A COPY MAY BE OBTAINED UPON REQUEST.

**BEVELED END SECTIONS**  
**STANDARD PLAN B-70.20-00**  
 SHEET 1 OF 1 SHEET

APPROVED FOR PUBLICATION

**Harold J. Peterfeso** 06-01-06

STATE DESIGN ENGINEER DATE



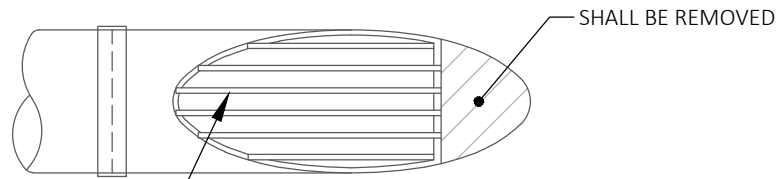

**PLAN VIEW**

3/4" DIA SMOOTH BARS WITH ENDS WELDED TO BAR-FRAME

1/4" X 2" FB ANCHOR STRIPS FASTENED WITH 1/2" NON-CORROSIVE BOLTS AND NUTS HEX HEAD (4 PLACES TYP)

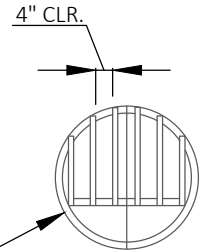

**END VIEW**

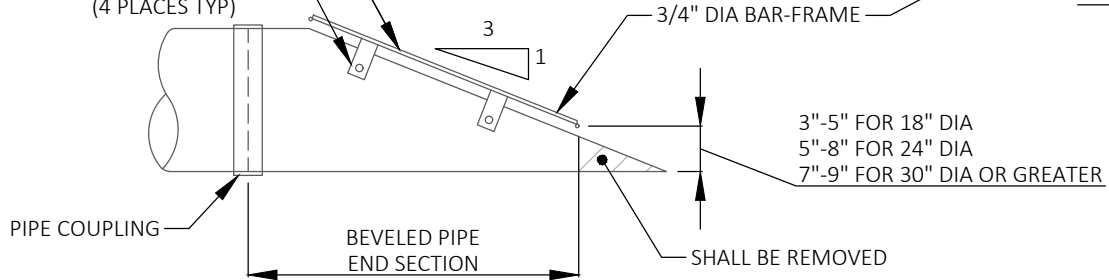

**SECTION VIEW**

**NOTES:**

1. CMP END-SECTION SHOWN. FOR CONCRETE PIPE BEVELED END-SECTION, SEE WSDOT STD B-70.20-00.
2. ALL PARTS MUST BE ALUMINUM OR STAINLESS STEEL.
3. TRASH RACKS REQUIRED ON ALL PIPES 18" AND LARGER IN DIAMETER OR AS DIRECTED BY ENGINEER.

*Tricia Juhnke*

APPROVED BY: TRICIA JUHNKE  
CITY ENGINEER



STANDARD DETAIL NUMBER: **702** SCALE: **NOT TO SCALE**

**TRASH RACK**

PUBLICATION DATE: 3/1/2021 REVISION DATE: 2/10/2021

3/4" DIAMETER SMOOTH BARS  
EQUALLY SPACED (4" O.C. MAX)

4 HOOK CLAMPS EVENLY PLACED  
SEE DETAIL BELOW.

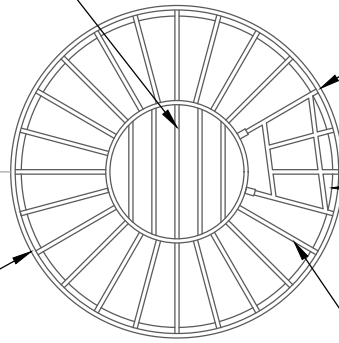

PROVIDE MAINTENANCE ACCESS  
BY WELDING 4 CROSSBARS TO 4  
VERTICAL BARS AS SHOWN. HINGE  
UPPER ENDS WITH FLANGES/BOLTS  
AND PROVIDE LOCKING  
MECHANISM (PADLOCK) ON  
LOWER END. LOCATE STEPS  
DIRECTLY BELOW.

LOWER STEEL BAND 3/4"x 4" WIDE  
FORMED TO FIT IN GROOVE OF CB  
RISER

**PLAN VIEW**

UPPER STEEL BAND 3/4"x 4"  
WIDE

LOWER STEEL BAND 3/4"x 4" WIDE  
FORMED TO FIT IN GROOVE OF CB  
RISER

24"  
SEE NOTE 1

3/4" DIA SMOOTH ROUND BARS  
WELDED TO UPPER AND LOWER  
BANDS. EQUALLY SPACED. BARS SHALL  
BE EVENLY SPACED (SEE NOTE 1)

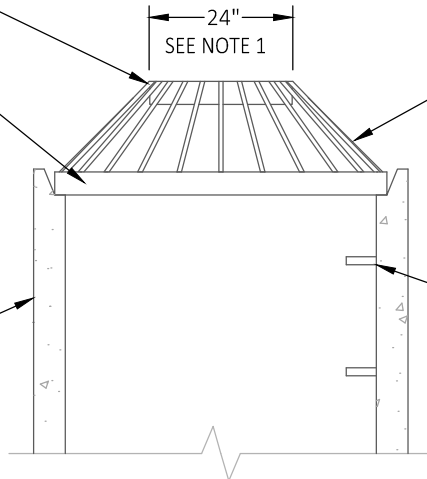

STANDARD LADDER

CB TYPE 2

**SECTION A**



SMOOTH VERTICAL  
BARS

HOOK CLAMP ANCHORED  
TO CB RISER

CB RISER

**DETAIL HOOK CLAMP**

**NTS**

**NOTES:**

1. DIMENSIONS ARE FOR ILLUSTRATION ON 54 IN. DIAMETER MH. FOR DIFFERENT DIAMETER MH'S, ADJUST TO MAINTAIN 45 DEGREE ANGLE ON "VERTICAL" BARS AND 7 IN. O.C. MAXIMUM SPACING OF BARS AROUND LOWER STEEL BAND.
2. METAL PARTS MUST BE CORROSION RESISTANT. BARS MUST BE STAINLESS STEEL OR ALUMINIZED STEEL.
3. THIS DEBRIS BARRIER IS ALSO RECOMMENDED FOR USE ON THE INLET TO ROADWAY CROSS-CULVERTS WITH HEIGHT POTENTIAL FOR DEBRIS COLLECTION (EXCEPT ON TYPE 2 STREAMS)
4. USE OF THIS STRUCTURE WITHIN THE ROAD RIGHT-OF-WAY SHALL MEET THE MINIMUM CLEAR ZONE REQUIREMENTS.
5. SEE THE WSDOT/APWA STANDARD SPECIFICATIONS SECTION 9-05.15 FOR METAL CASTINGS REQUIREMENTS.

*Tricia Juhnke*

APPROVED BY: TRICIA JUHNKE  
CITY ENGINEER



STANDARD DETAIL NUMBER: **703** SCALE: **NOT TO SCALE**

**DEBRIS CAGE**

PUBLICATION DATE: 3/1/2021 REVISION DATE: 2/10/2021

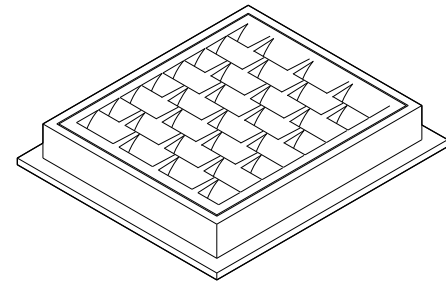

**FRAME AND VANED GRATE**

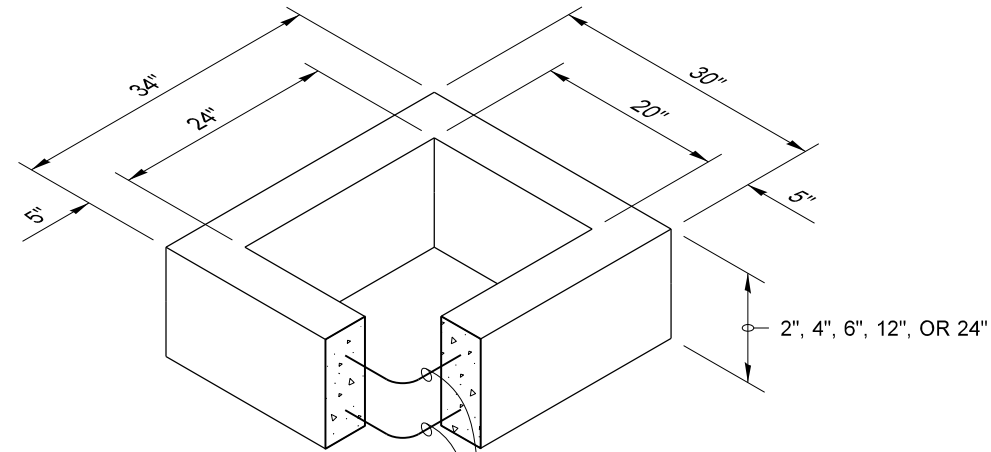

**RECTANGULAR ADJUSTMENT SECTION**

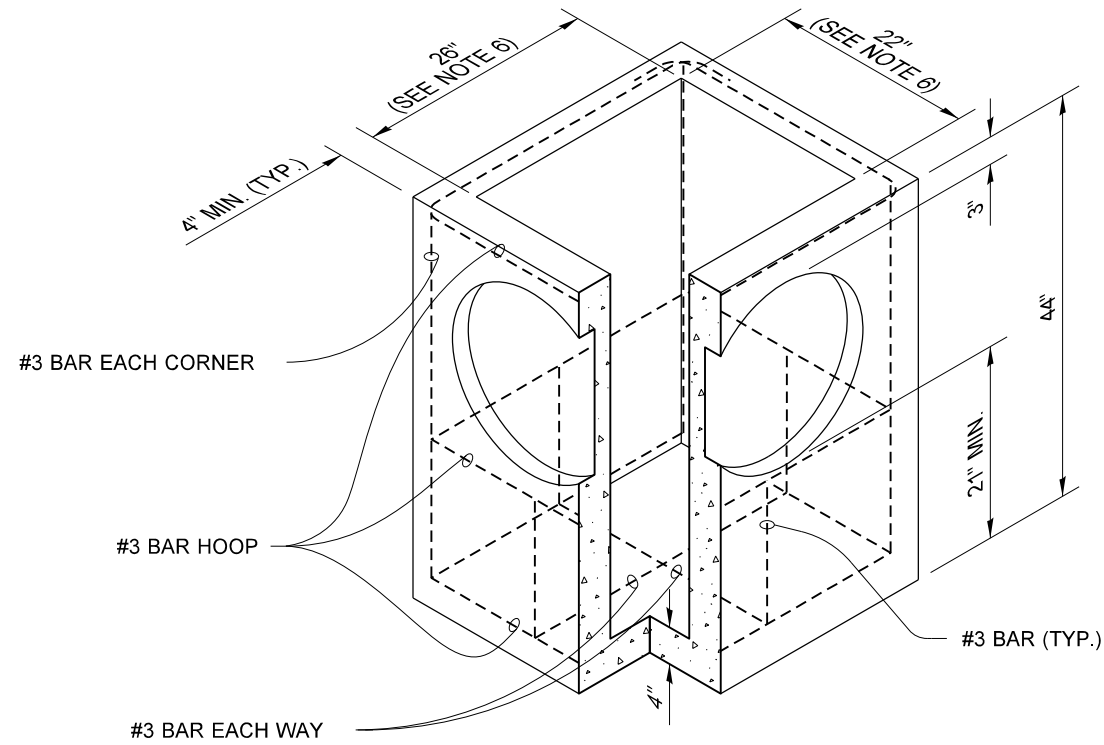

**PRECAST BASE SECTION**

PIPE ALLOWANCES	
PIPE MATERIAL	MAXIMUM INSIDE DIAMETER (INCHES)
REINFORCED OR PLAIN CONCRETE	12"
ALL METAL PIPE	15"
CPSSP * (STD. SPEC. SECT. 9-05.20)	12"
SOLID WALL PVC (STD. SPEC. SECT. 9-05.12(1))	15"
PROFILE WALL PVC (STD. SPEC. SECT. 9-05.12(2))	15"

\* CORRUGATED POLYETHYLENE STORM SEWER PIPE

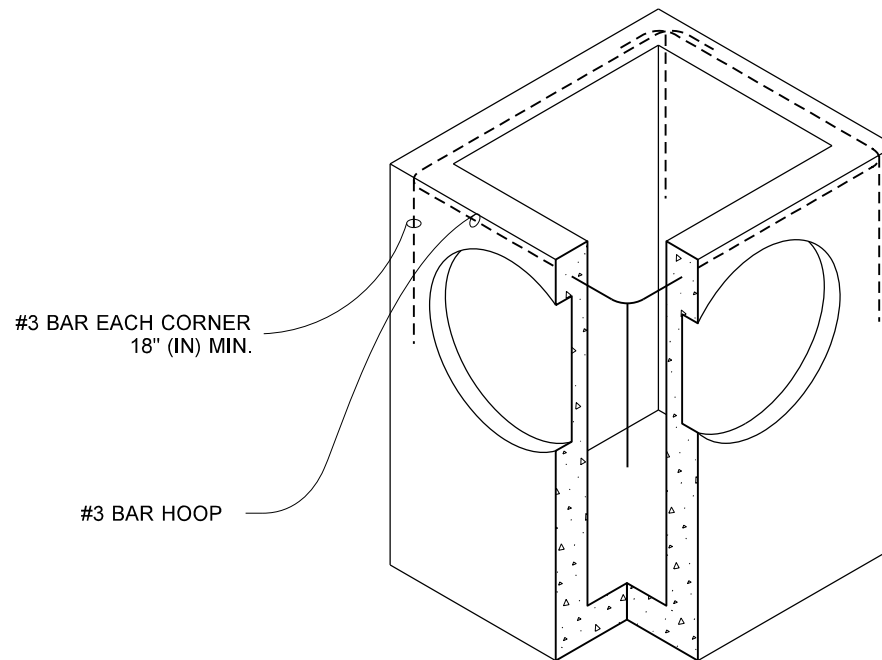

(SEE NOTE 1)  
**ALTERNATIVE PRECAST BASE SECTION**

**NOTES**

1. As acceptable alternatives to the rebar shown in the **PRECAST BASE SECTION**, fibers (placed according to the Standard Specifications), or wire mesh having a minimum area of 0.12 square inches per foot shall be used with the minimum required rebar shown in the **ALTERNATIVE PRECAST BASE SECTION**. Wire mesh shall not be placed in the knockouts.
2. The knockout diameter shall not be greater than 20" (in). Knockouts shall have a wall thickness of 2" (in) minimum to 2.5" (in) maximum. Provide a 1.5" (in) minimum gap between the knockout wall and the outside of the pipe. After the pipe is installed, fill the gap with joint mortar in accordance with **Standard Specification Section 9-04.3**.
3. The maximum depth from the finished grade to the lowest pipe invert shall be 5' (ft).
4. The frame and grate may be installed with the flange down, or integrally cast into the adjustment section with flange up.
5. The Precast Base Section may have a rounded floor, and the walls may be sloped at a rate of 1 : 24 or steeper.
6. The opening shall be measured at the top of the **Precast Base Section**.
7. All pickup holes shall be grouted full after the basin has been placed.



Heilman, Julie  
Jan 25 2017 2:53 PM  
cosign

**CATCH BASIN TYPE 1**

**STANDARD PLAN B-5.20-02**

SHEET 1 OF 1 SHEET

APPROVED FOR PUBLICATION  
Carpenter, Jeff  
Jan 26 2017 6:48 AM  
cosign

STATE DESIGN ENGINEER





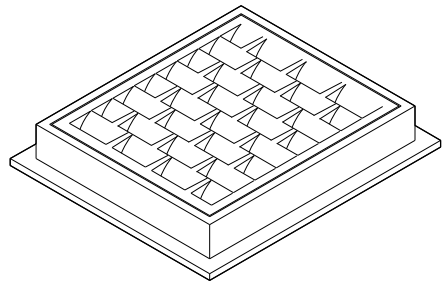

**FRAME AND VANED GRATE**

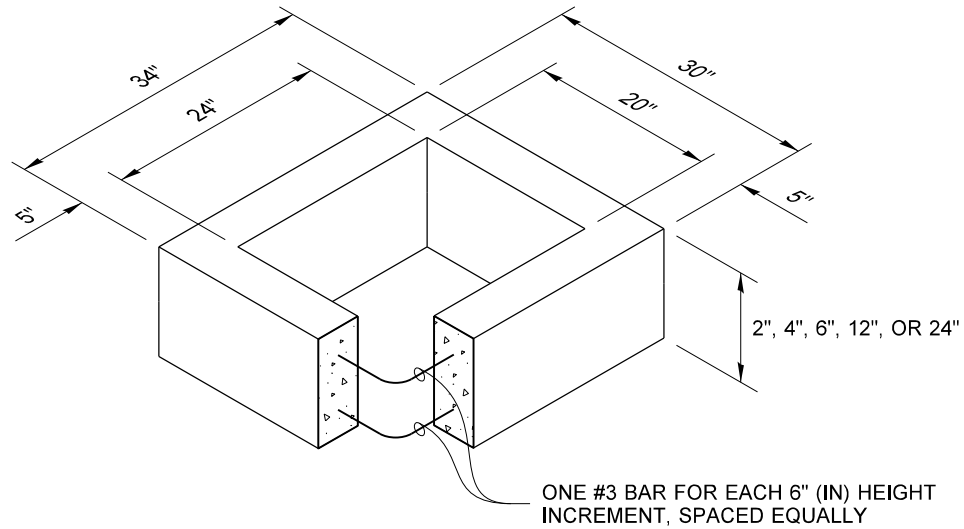

**RECTANGULAR ADJUSTMENT SECTION**

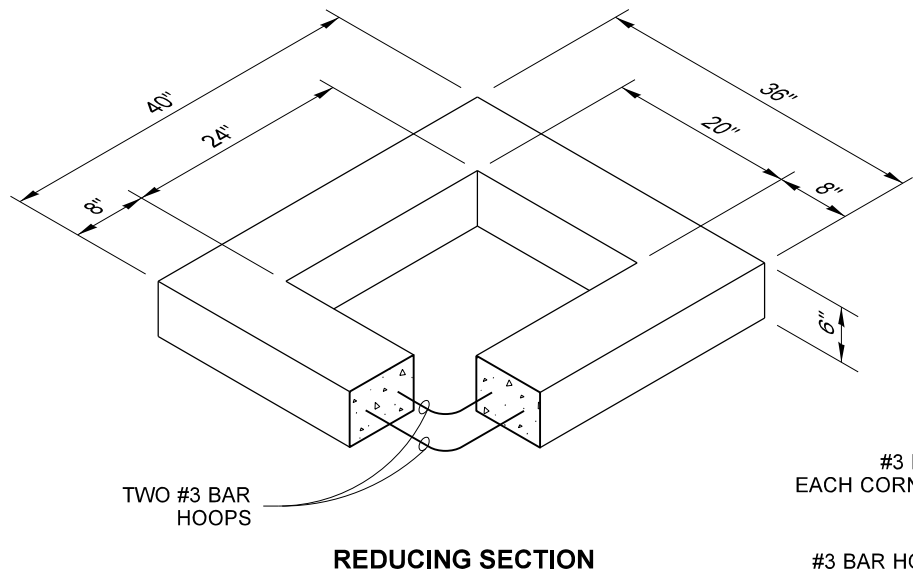

**REDUCING SECTION**

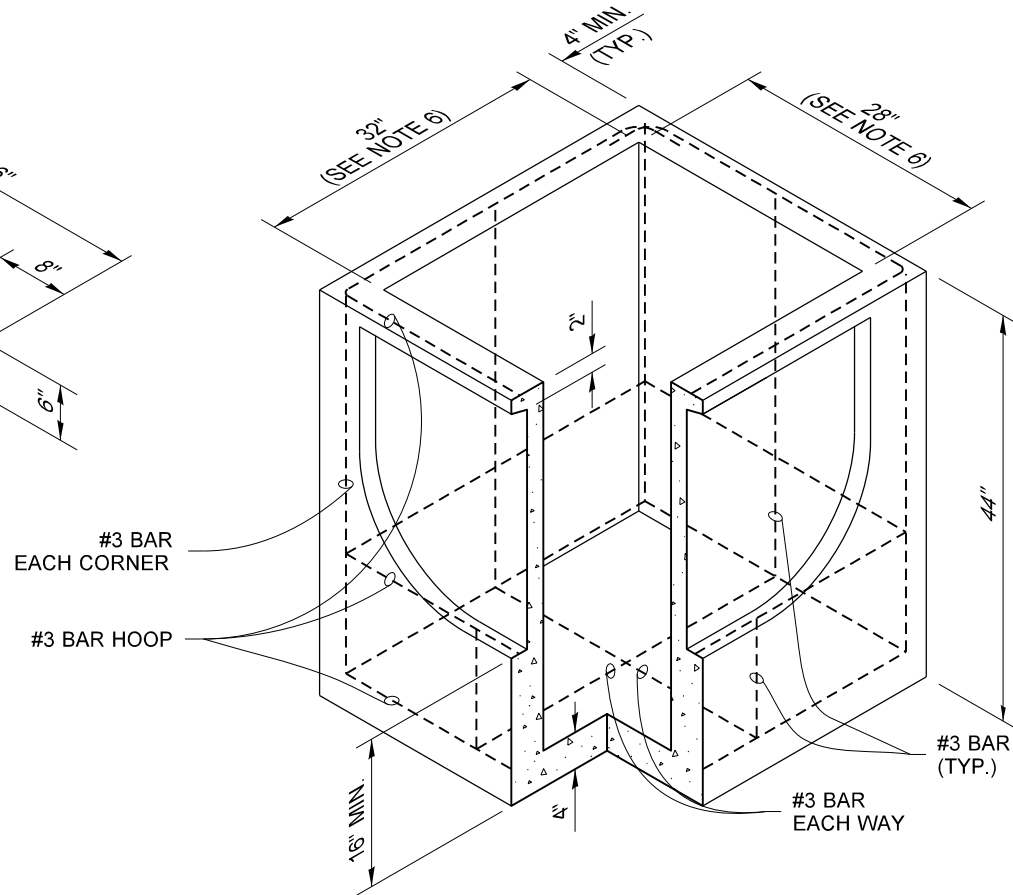

**PRECAST BASE SECTION**

PIPE ALLOWANCES	
PIPE MATERIAL	MAXIMUM INSIDE DIAMETER (INCHES)
REINFORCED OR PLAIN CONCRETE	18"
ALL METAL PIPE	21"
CPSSP * (STD. SPEC. SECT. 9-05.20)	18"
SOLID WALL PVC (STD. SPEC. SECT. 9-05.12(1))	21"
PROFILE WALL PVC (STD. SPEC. SECT. 9-05.12(2))	21"

\* CORRUGATED POLYETHYLENE STORM SEWER PIPE

**NOTES**

1. As acceptable alternatives to the rebar shown in the **PRECAST BASE SECTION**, fibers (placed according to the Standard Specifications), or wire mesh having a minimum area of 0.12 square inches per foot, shall be used with the minimum required rebar shown in the **ALTERNATIVE PRECAST BASE SECTION**. Wire mesh shall not be placed in the knockouts.
2. The knockout shall not be greater than 26" (in), in any direction. Knockouts shall have a wall thickness of 2" (in) minimum to 2.5" (in) maximum. Provide a 1.5" (in) minimum gap between the knockout wall and the outside of the pipe. After the pipe is installed, fill the gap with joint mortar in accordance with **Standard Specification Section 9-04.3**.
3. The maximum depth from the finished grade to the lowest pipe invert shall be 5' (ft).
4. The frame and grate may be installed with the flange down or integrally cast into the adjustment section with flange up.
5. The Precast Base Section may have a rounded floor, and the walls may be sloped at a rate of 1 : 24 or steeper.
6. The opening shall be measured at the top of the Precast Base Section.
7. All pickup holes shall be grouted full after the basin has been placed.

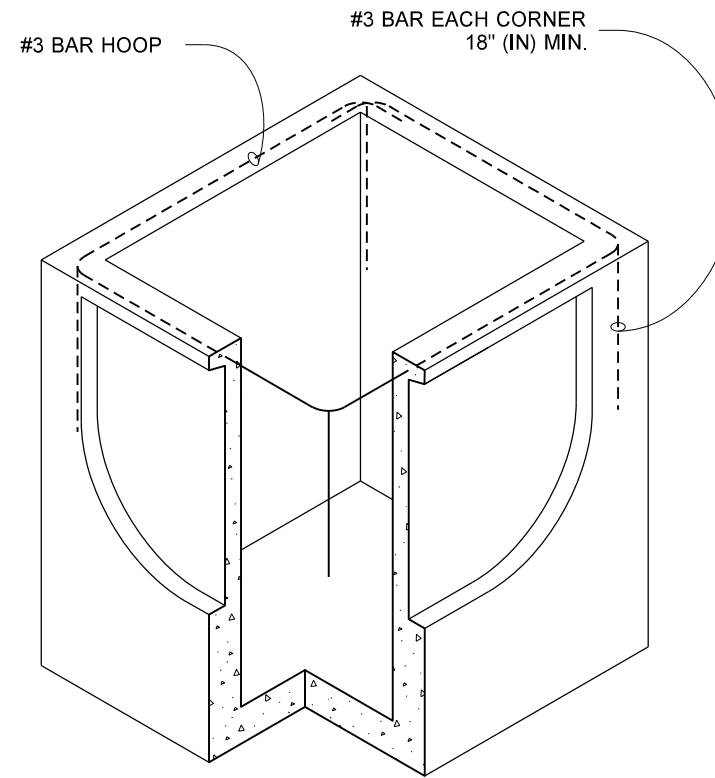

**ALTERNATIVE PRECAST BASE SECTION**



Heilman, Julie  
Jan 25 2017 2:56 PM  
cosign

**CATCH BASIN TYPE 1L**

**STANDARD PLAN B-5.40-02**

SHEET 1 OF 1 SHEET

APPROVED FOR PUBLICATION

Carpenter, Jeff  
Jan 26 2017 6:49 AM  
cosign

STATE DESIGN ENGINEER



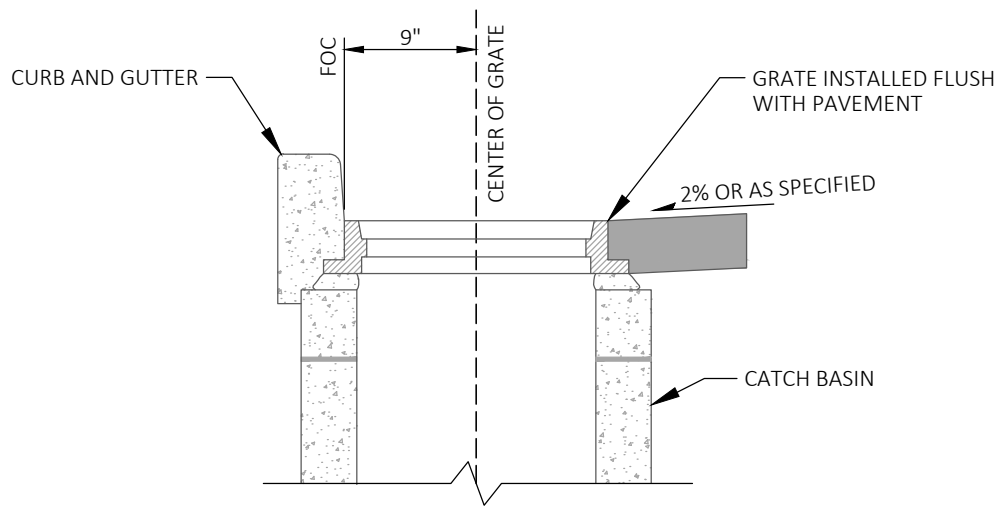

**SECTION A-A**

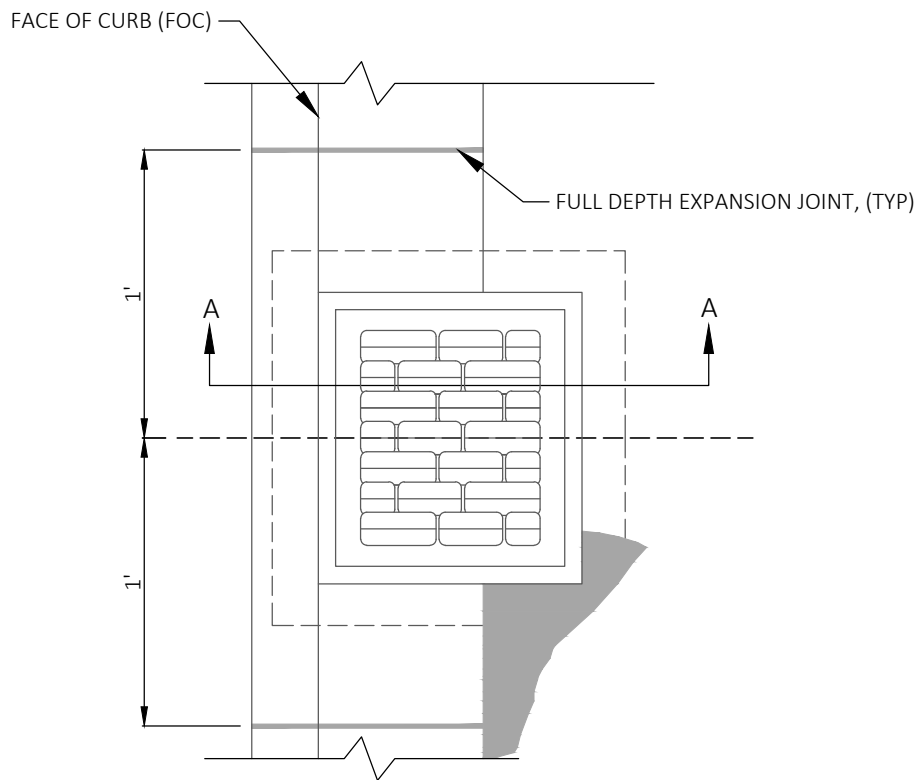

**PLAN VIEW**

**NOTES:**

1. AN APPROVED MATERIAL WHICH WILL PREVENT BONDING OF THE CURB TO FRAME, GRATE OR C.B. SHALL BE USED.
2. GROUT ALL JOINTS INSIDE AND OUTSIDE.
3. ALL GRATES SHALL BE VANED UNLESS OTHERWISE SHOWN.

*Tricia Juhnke*

APPROVED BY: TRICIA JUHNKE  
CITY ENGINEER



STANDARD DETAIL NUMBER: **707** SCALE: **NOT TO SCALE**

**CATCH BASIN INSTALLATION**

PUBLICATION DATE: 3/1/2021

REVISION DATE: 2/11/2020

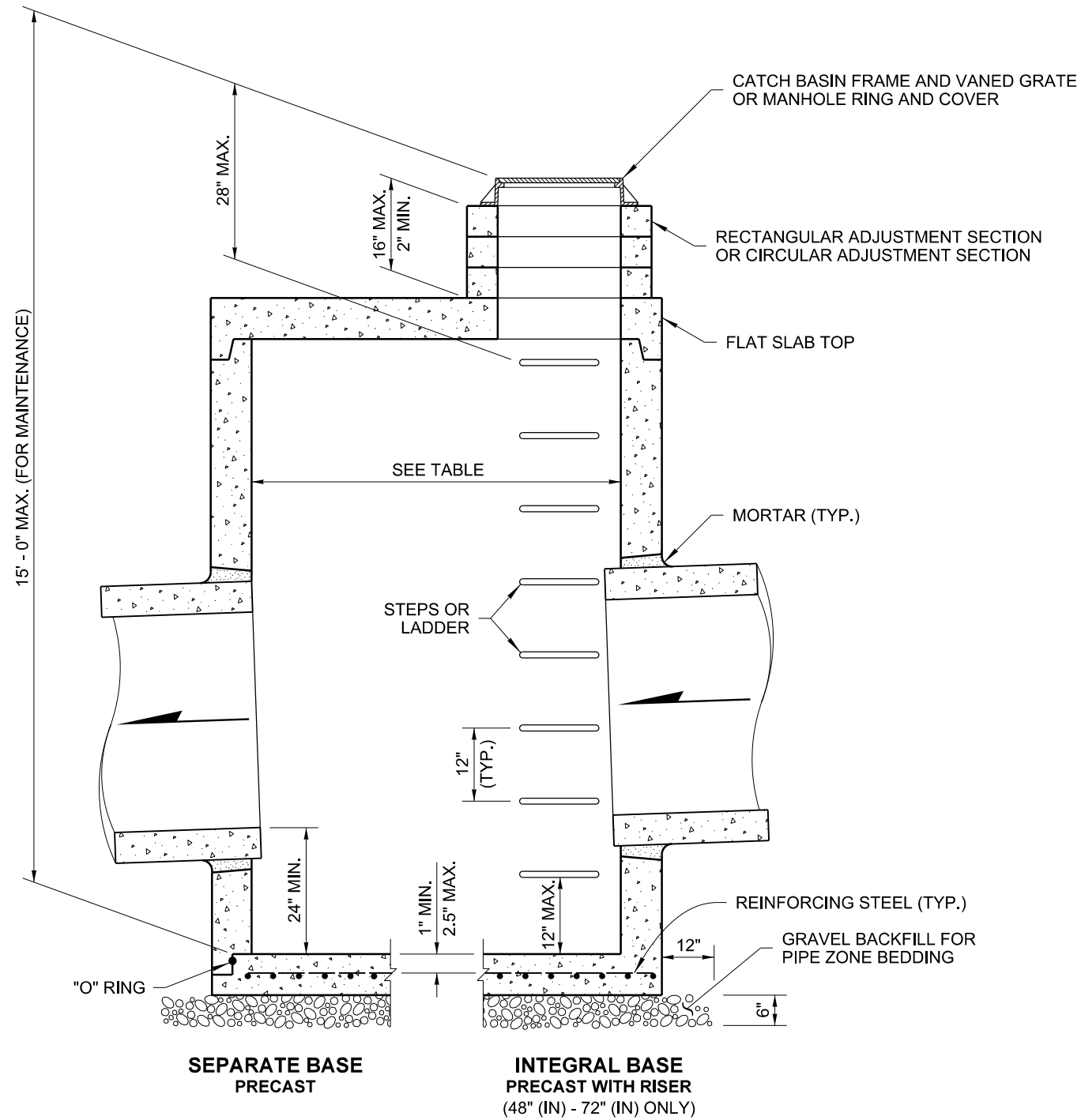

**NOTES**

1. No steps are required when height is 4' or less.
2. The bottom of the precast catch basin may be sloped to facilitate cleaning.
3. The rectangular frame and grate may be installed with the flange up or down. The frame may be cast into the adjustment section.
4. Knockouts shall have a wall thickness of 2" (in) minimum to 2.5" (in) maximum. Provide a 1.5" (in) minimum gap between the knockout wall and the outside of the pipe. After the pipe is installed, fill the gap with joint mortar in accordance with **Standard Specification Section 9-04.3**.

CATCH BASIN DIMENSIONS				
CATCH BASIN DIAMETER	MIN. WALL THICKNESS	MIN. BASE THICKNESS	MAXIMUM KNOCKOUT SIZE	MINIMUM DISTANCE BETWEEN KNOCKOUTS
48"	4"	6"	36"	8"
54"	4.5"	8"	42"	8"
60"	5"	8"	48"	8"
72"	6"	8"	60"	12"
84"	8"	12"	72"	12"
96"	8"	12"	84"	12"
120"	10"	12"	96"	12"
144"	12"	12"	108"	12"

PIPE ALLOWANCES					
CATCH BASIN DIAMETER	PIPE MATERIAL WITH MAXIMUM INSIDE DIAMETER				
	CONCRETE	ALL METAL	CPSSP ① PP ④	SOLID WALL PVC ②	PROFILE WALL PVC ③
48"	24"	30"	24"	30"	30"
54"	30"	36"	30"	36"	36"
60"	36"	42"	36"	42"	42"
72"	42"	54"	42"	48"	48"
84"	54"	60"	54"	48"	48"
96"	60"	72"	60"	48"	48"
120"	66"	84"	60"	48"	48"
144"	78"	96"	60"	48"	48"

- ① Corrugated Polyethylene Storm Sewer Pipe (See **Standard Specification Section 9-05.20**)
- ② (See **Standard Specification Section 9-05.12(1)**)
- ③ (See **Standard Specification Section 9-05.12(2)**)
- ④ Polypropylene Pipe (See **Standard Specification Section 9-05.24**)



Heilman, Julie  
Feb 20 2018 12:49 PM  
cosign

**CATCH BASIN TYPE 2**

**STANDARD PLAN B-10.20-02**

SHEET 1 OF 1 SHEET

APPROVED FOR PUBLICATION

*Jeff Cooper*  
Carpenter, Jeff  
Mar 2 2018 10:01 AM  
cosign

STATE DESIGN ENGINEER  
Washington State Department of Transportation

DRAWN BY: FERN LIDDELL

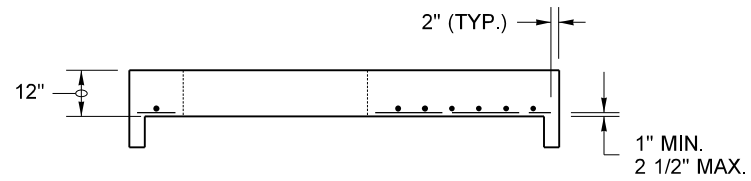
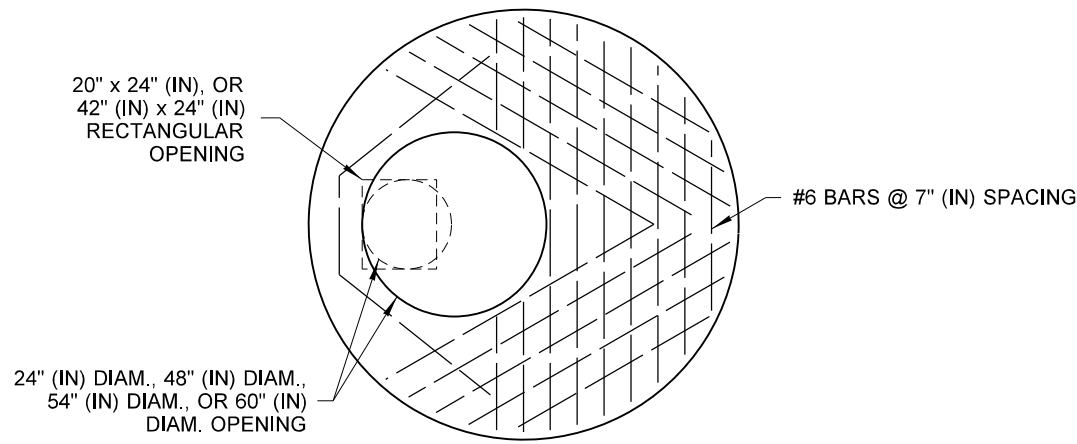

**84" (IN) or 96" (IN) FLAT SLAB TOP**

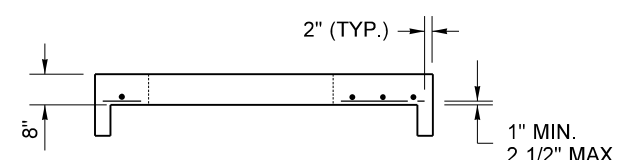
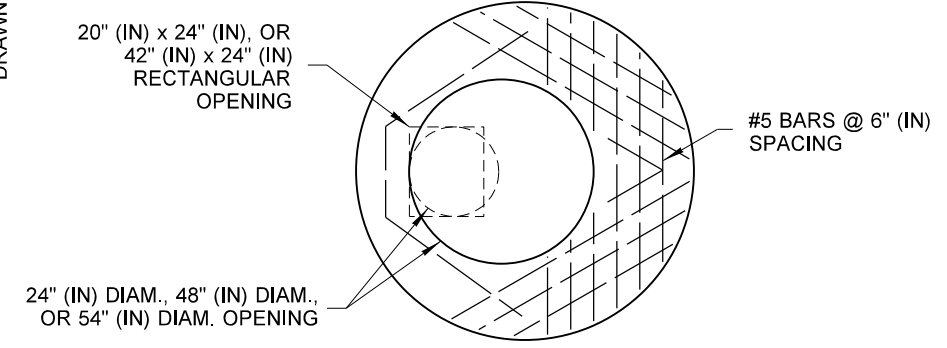

**72" (IN) FLAT SLAB TOP**

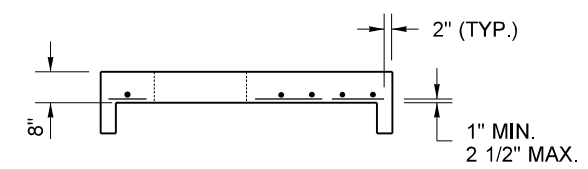
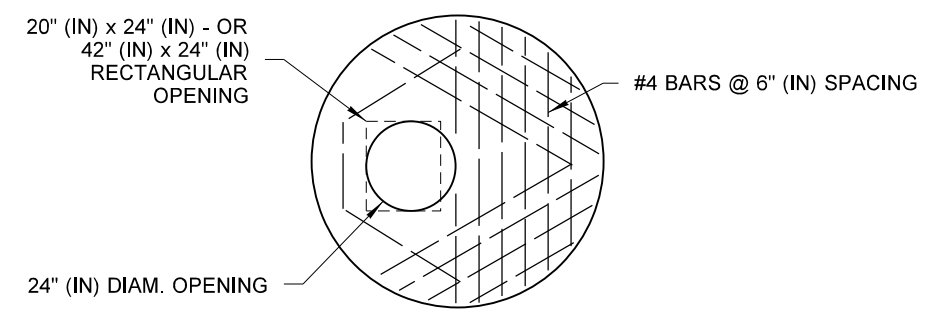

**48" (IN), 54", or 60" (IN) FLAT SLAB TOP**

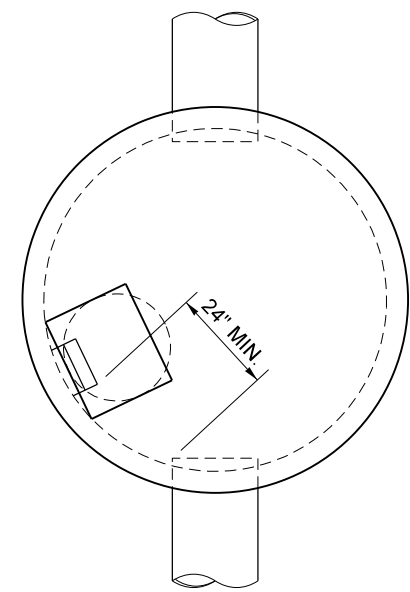

**TYPICAL ORIENTATION FOR ACCESS AND STEPS**

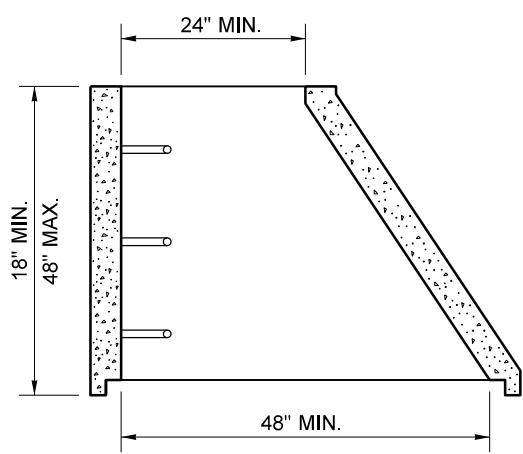

**ECCENTRIC CONE SECTION**

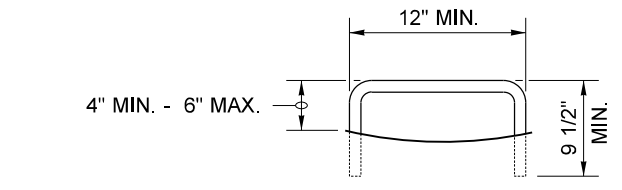

**STEP**

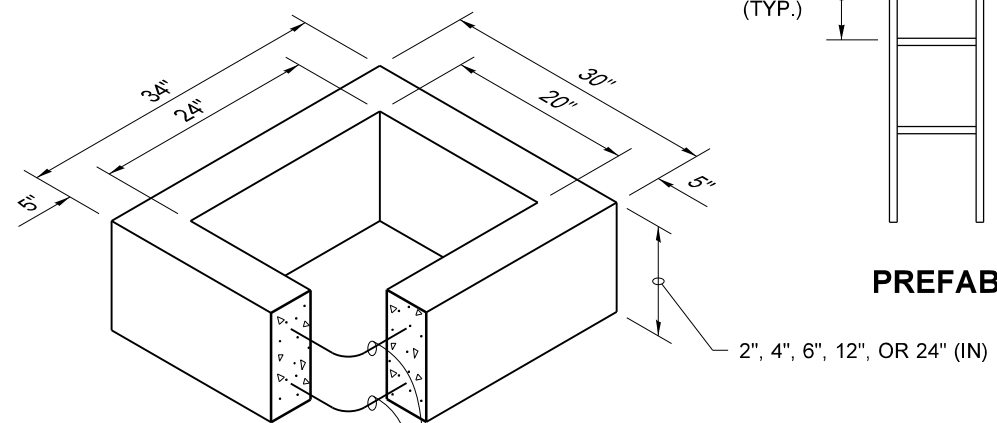

**PREFABRICATED LADDER**

- 1 ONE #3 BAR HOOP FOR 2", 4", OR 6" (IN)
- 2 TWO #3 BAR HOOPS FOR 12" (IN)
- FOUR #3 BAR HOOPS FOR 24" (IN)

**RECTANGULAR ADJUSTMENT SECTION**

- 1 As an acceptable alternative to rebar, wire mesh having a minimum area of 0.12 square inches per foot may be used for adjustment sections.
- 2 As an acceptable alternative to conventional steel reinforcement, manufacturers shall use Synthetic Structural Fibers meeting the requirements of **Standard Specification Section 9-05.50(10)**.

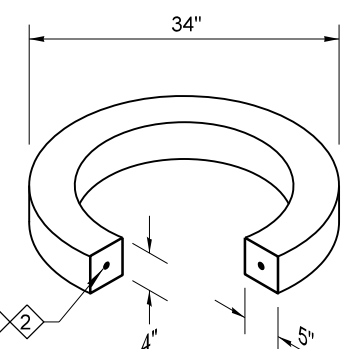

- 1 ONE #3 BAR HOOP FOR 2", 4", OR 6" (IN)
- 2 TWO #3 BAR HOOPS FOR 12" (IN)

**CIRCULAR ADJUSTMENT SECTION**

For rectangular and circular adjustment sections, approved alternate material compositions are acceptable in lieu of precast concrete designs

**NOTE**

- 1. Ladder rungs for manholes and catch basins shall meet the requirements of **AASHTO M 199**.



Julie Heilman  
Heilman, Julie  
Jan 25 2017 3:01 PM

**MISCELLANEOUS DETAILS FOR DRAINAGE STRUCTURES STANDARD PLAN B-30.90-02**

SHEET 1 OF 1 SHEET

APPROVED FOR PUBLICATION  
Carpenter, Jeff  
Jan 26 2017 6:52 AM

STATE DESIGN ENGINEER  
Washington State Department of Transportation

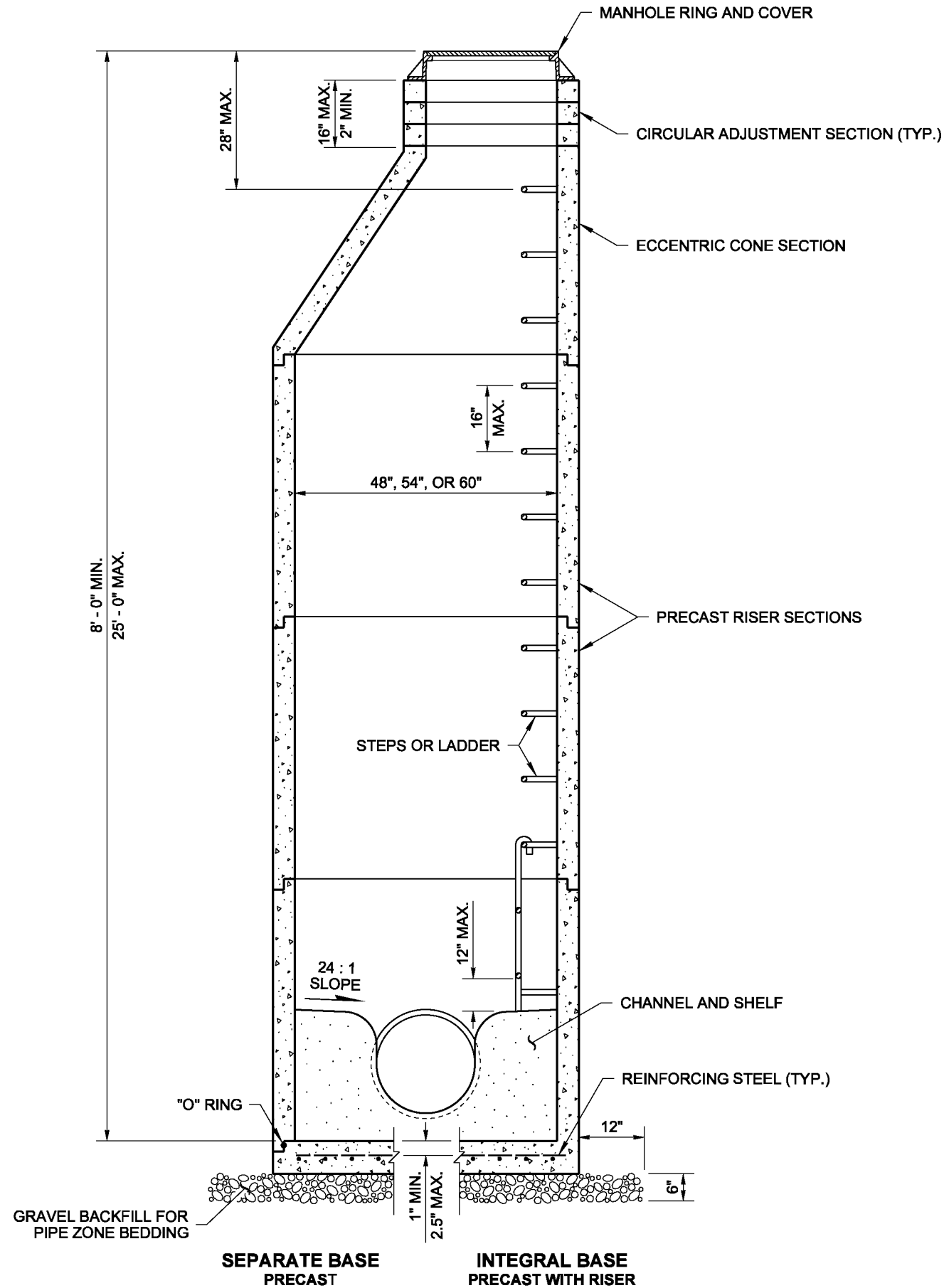

**NOTES**

1. Knockouts shall have a wall thickness of 2" minimum to 2.5" maximum.
2. For pipe allowances, see **Standard Plan B-10.20**.

MANHOLE DIMENSION TABLE				
DIAM.	MIN. WALL THICKNESS	MIN. BASE THICKNESS	MAXIMUM KNOCKOUT SIZE	MINIMUM DISTANCE BETWEEN KNOCKOUTS
48"	4"	6"	36"	8"
54"	4.5"	8"	42"	8"
60"	5"	8"	48"	8"



NOTE: THIS PLAN IS NOT A LEGAL ENGINEERING DOCUMENT UNTIL ELECTRONICALLY SIGNED BY THE ENGINEER AND APPROVED FOR PUBLICATION. IT IS THE OBLIGATION OF THE ENGINEER TO FILE AT THE WASHINGTON STATE DEPARTMENT OF TRANSPORTATION. A COPY MAY BE OBTAINED UPON REQUEST.

**MANHOLE TYPE 1**

**STANDARD PLAN B-15.20-01**

SHEET 1 OF 1 SHEET

APPROVED FOR PUBLICATION

**Pasco Bakotich III** 02-07-12

STATE DESIGN ENGINEER DATE



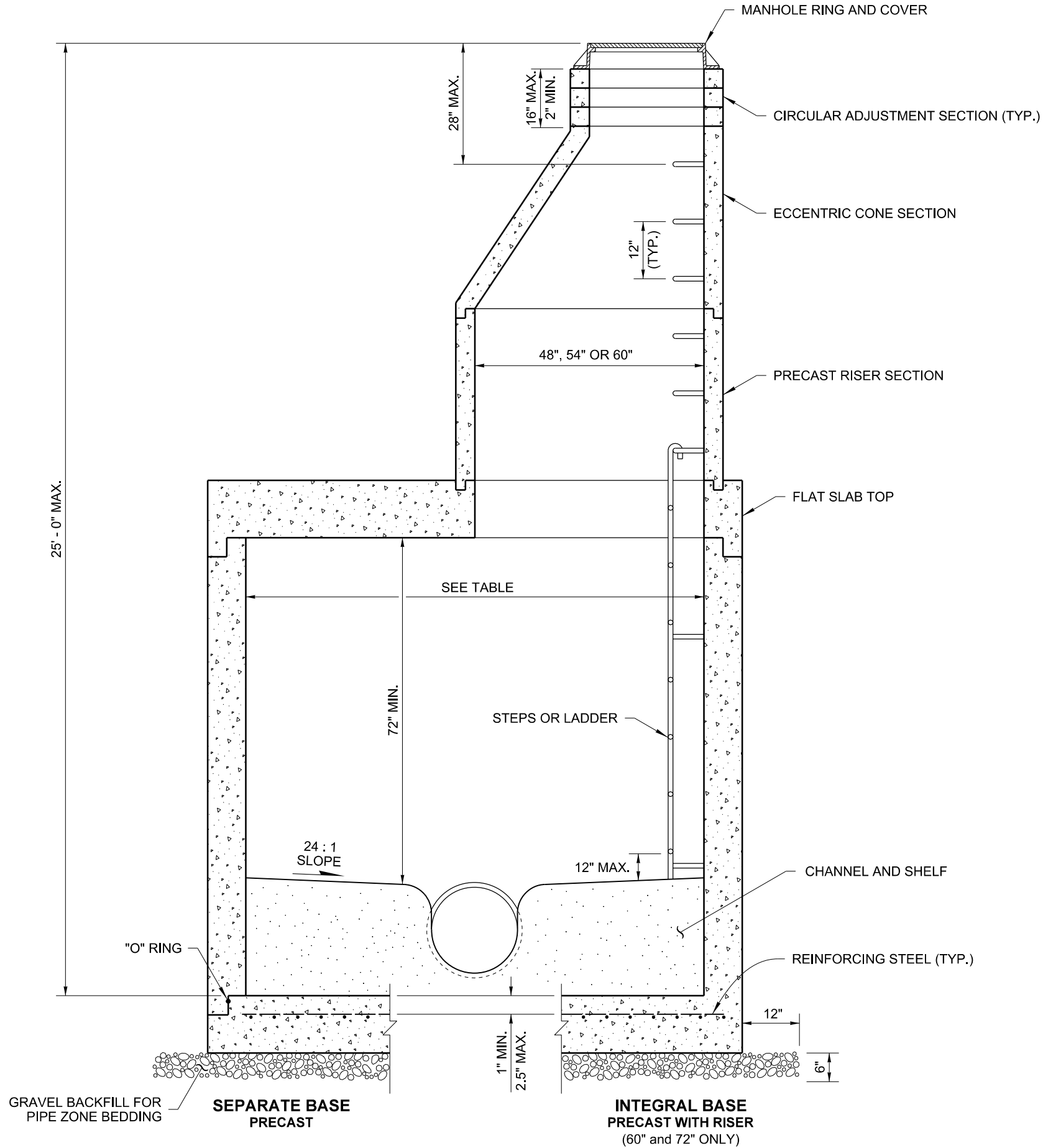

**NOTES**

1. Knockouts shall have a wall thickness of 2" minimum to 2.5" maximum.
2. For pipe allowances, see **Standard Plan B-10.20**.

MANHOLE DIMENSION TABLE				
DIAM.	MIN. WALL THICKNESS	MIN. BASE THICKNESS	MAXIMUM KNOCKOUT SIZE	MINIMUM DISTANCE BETWEEN KNOCKOUTS
60"	5"	8"	48"	8"
72"	6"	8"	60"	12"
84"	8"	12"	72"	12"
96"	8"	12"	84"	12"
120"	10"	12"	96"	12"
144"	12"	12"	108"	12"



NOTE: THIS PLAN IS NOT A LEGAL ENGINEERING DOCUMENT BUT AN ELECTRONIC DIGITAL COPY. THE ORIGINAL COPY OF THE ENGINEER AND APPROVED FOR PUBLICATION IS KEPT ON FILE AT THE WASHINGTON STATE DEPARTMENT OF TRANSPORTATION. A COPY MAY BE OBTAINED UPON REQUEST.

**MANHOLE TYPE 2**  
**STANDARD PLAN B-15.40-01**  
 SHEET 1 OF 1 SHEET

APPROVED FOR PUBLICATION

**Pasco Bakotich III** 02-07-12  
 STATE DESIGN ENGINEER DATE

Washington State Department of Transportation

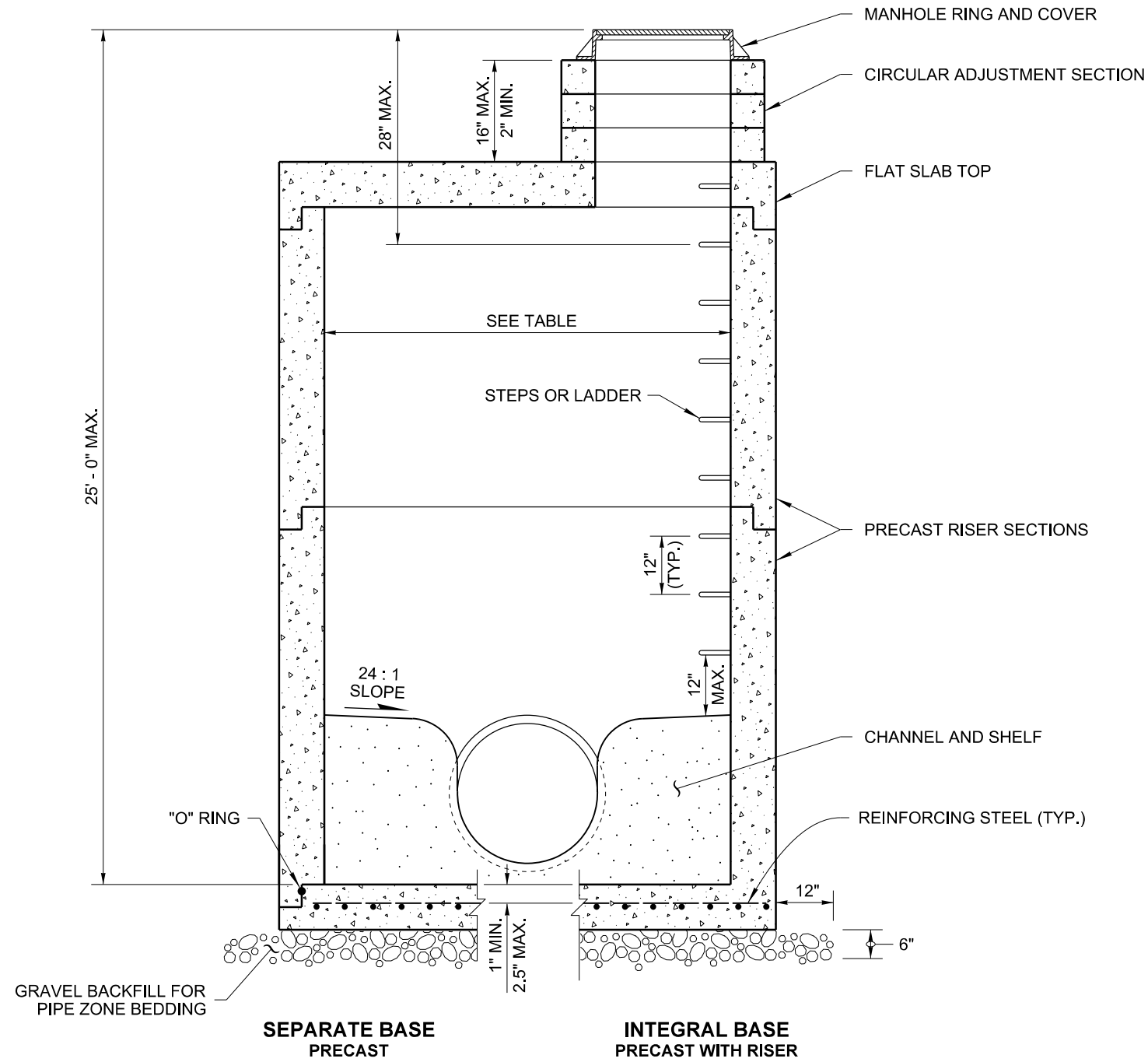

**NOTES**

1. Knockouts shall have a wall thickness of 2" (in) minimum to 2.5" (in) maximum.
2. For pipe allowances, see **Standard Plan B-10.20**.
3. No steps are required when height is 4' (ft) or less.

MANHOLE DIMENSION TABLE				
DIAM.	MIN. WALL THICKNESS	MIN. BASE THICKNESS	MAXIMUM KNOCKOUT SIZE	MINIMUM DISTANCE BETWEEN KNOCKOUTS
48"	4"	6"	36"	8"
54"	4.5"	8"	42"	8"
60"	5"	8"	48"	8"
72"	6"	8"	60"	12"
84"	8"	12"	72"	12"
96"	8"	12"	84"	12"
120"	10"	12"	96"	12"
144"	12"	12"	108"	12"



*Julie Heilman* Heilman, Julie  
 Jan 25 2017 2:58 PM  
 cosign

**MANHOLE TYPE 3**

**STANDARD PLAN B-15.60-02**

SHEET 1 OF 1 SHEET

APPROVED FOR PUBLICATION	
Carpenter, Jeff	
Jan 26 2017 6:50 AM	
STATE DESIGN ENGINEER	
Washington State Department of Transportation	

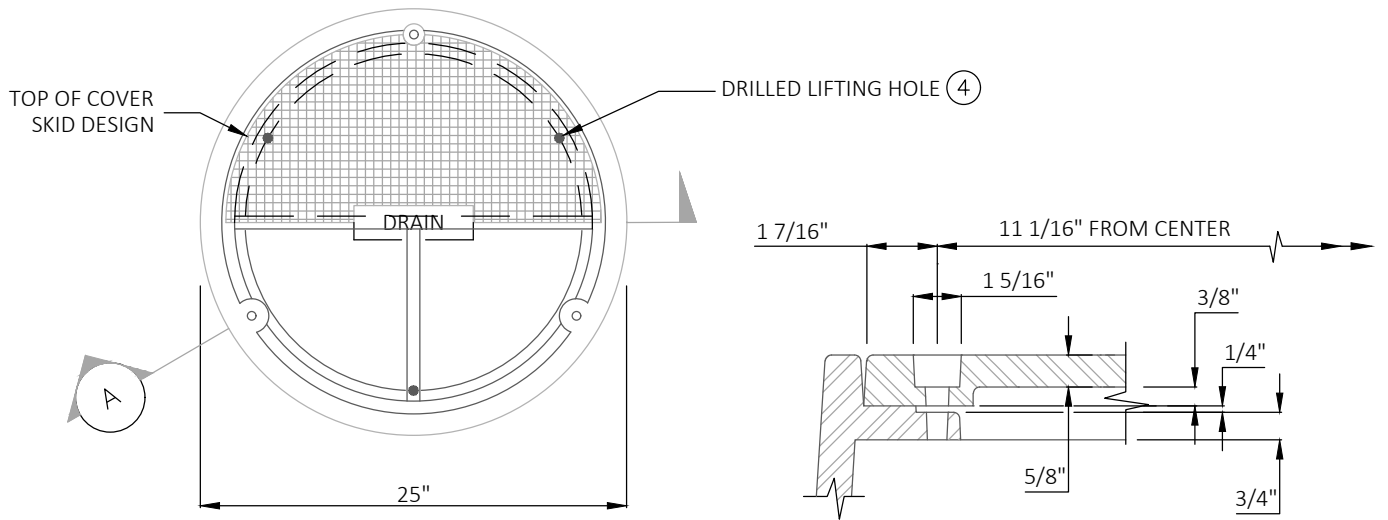

**PLAN**

**BOLT-DOWN DETAIL**

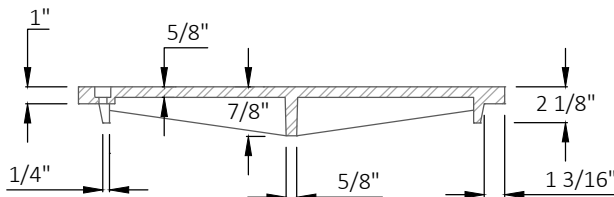

**SECTION A**

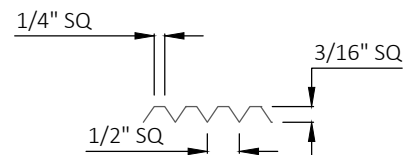

**COVER SKID DESIGN DETAIL**

**NOTES:**

1. THE GASKET AND GROOVE MAY BE IN THE SEAT (FRAME) OR IN THE UNDERSIDE OF THE COVER. THE GASKET MAY BE "T" SHAPED IN SECTION. THE GROOVE MAY BE CAST OR MACHINED.
2. BOLT-DOWN CAPABILITY IS REQUIRED ON ALL FRAMES, GRATES, AND COVERS, UNLESS SPECIFIED OTHERWISE IN THE CONTRACT. PROVIDE 3 HOLES IN THE FRAME THAT ARE VERTICALLY ALIGNED WITH THE GRATE OR COVER SLOTS. THE FRAME SHALL ACCEPT THE 304 STAINLESS STEEL (S.S) 5/8" - 11 NC X 2" (IN) ALLEN HEAD CAP SCREW BY BEING TAPPED, OR OTHER APPROVED MECHANISM. LOCATION OF BOLT DOWN HOLES VARIES BY MANUFACTURER.
3. FOR BOLT-DOWN MANHOLE RING AND COVERS THAT ARE NOT DESIGNATED "WATERTIGHT," THE NEOPRENE GASKET, GROOVE, AND WASHER ARE NOT REQUIRED.
- ④ DRILL THREE 1 IN HOLES SPACED AT 120° AND 9 1/2 IN RADIUS.
5. ALTERNATIVE REINFORCING DESIGNS ARE ACCEPTABLE IN LIEU OF THE RIB DESIGN.

*Tricia Juhnke*

APPROVED BY: TRICIA JUHNKE  
CITY ENGINEER



STANDARD DETAIL NUMBER: **720** SCALE: **NOT TO SCALE**

**MANHOLE RING AND COVER**

PUBLICATION DATE: 3/1/2021 REVISION DATE: 2/10/2021



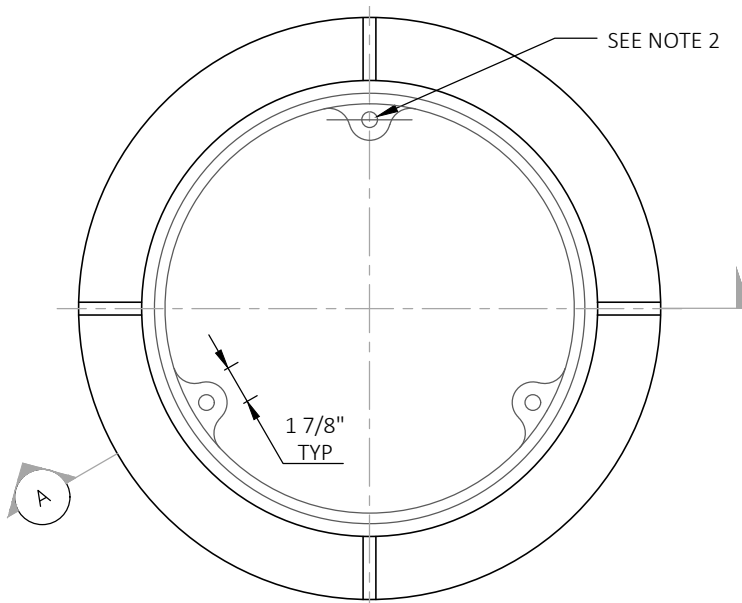

**PLAN**

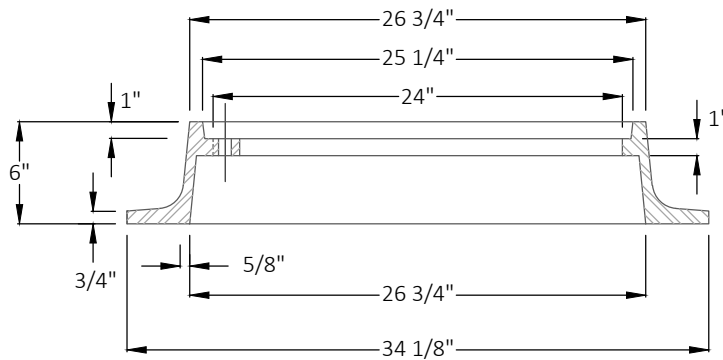

**SECTION A**

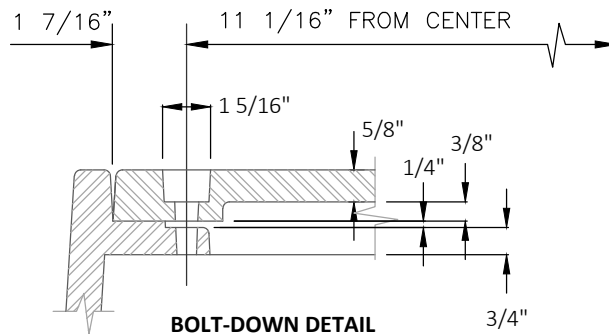

**BOLT-DOWN DETAIL**

**NOTES:**

1. MATERIAL IS CAST IRON ASTM A48 CLASS 30.
2. DRILL AND TAP THREE 5/8 IN-11 NC HOLES THROUGH FRAME AT 120° AND 11 1/16 IN RADIUS.
3. SEE WSDOT SPECIFICATION 7-05.
4. SEE THE WSDOT/APWA STANDARD SPECIFICATIONS SECTION 9-05.15 FOR METAL CASTINGS REQUIREMENTS.

*Tricia Juhnke*

APPROVED BY: TRICIA JUHNKE  
CITY ENGINEER



STANDARD DETAIL NUMBER: **721** SCALE: **NOT TO SCALE**

**LOCKING MANHOLE RING**

PUBLICATION DATE: 3/1/2021 REVISION DATE: 2/11/2020

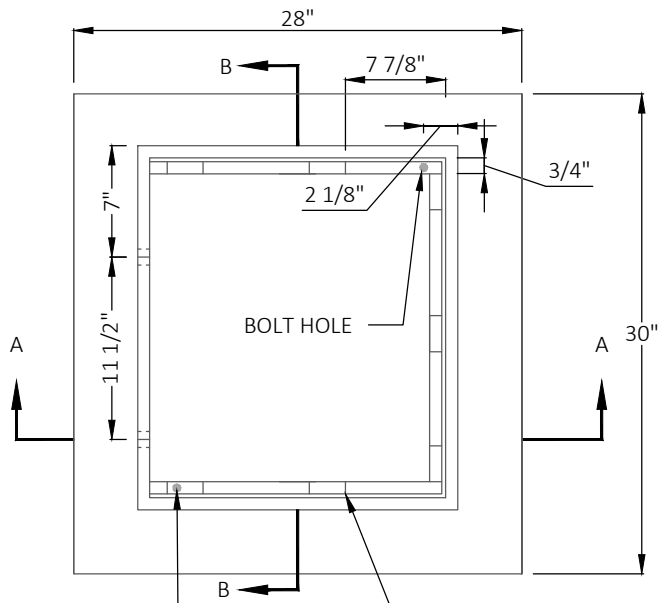

**PLAN**

LEVELING PAD  
7-1/8" X 3/4" X 2 1/4"  
TYP

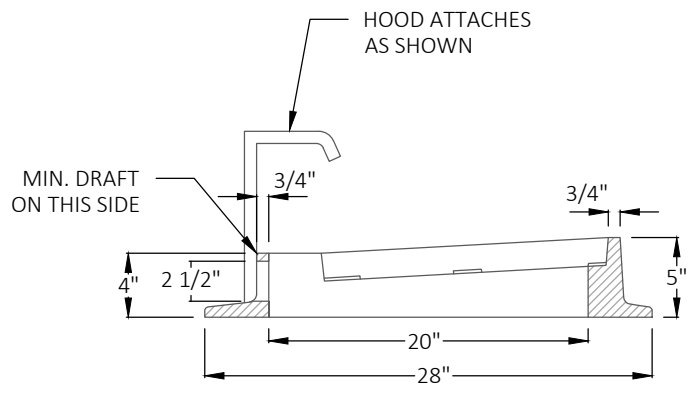

**SECTION A-A**

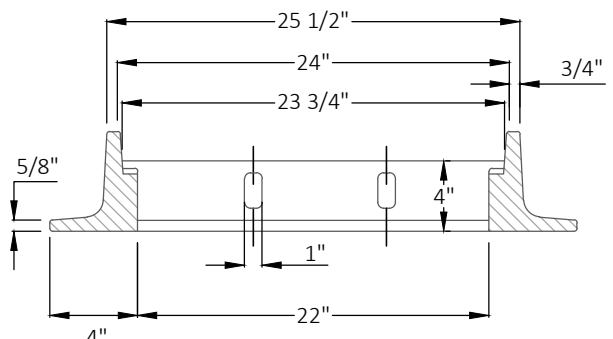

**SECTION B-B**

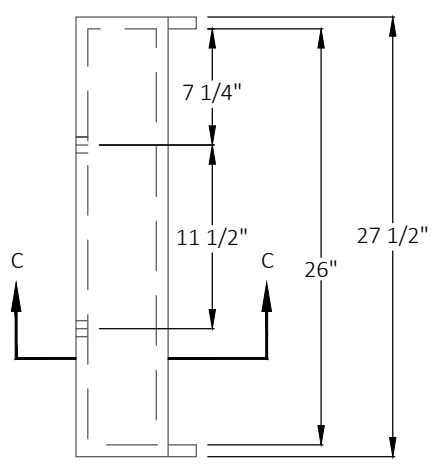

**HOOD DETAIL**

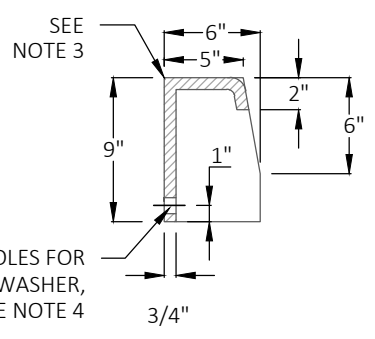

2 - 1" DIAM. HOLES FOR  
3/4" BOLT, WASHER,  
& NUT, SEE NOTE 4

**HOOD  
SECTION C-C**

- NOTES:
1. MATERIAL IS CAST IRON ASTM A48 CLASS 30.
  2. SEE STND DWG 726 FOR VANED GRATE.
  3. PATTERN ON TOP SURFACE OF HOOD SHALL BE 3/16" NON-SKID.
  4. BOLT, WASHER, & NUT SHALL BE GALVANIZED OR EROSION RESISTANT.
  5. INSTALL CITY PROVIDED METAL MEDALLION (SEE STND DETAIL 725).

STANDARD DETAIL NUMBER: **724** SCALE: **NOT TO SCALE**

*Tricia Juhnke*  
APPROVED BY: TRICIA JUHNKE  
CITY ENGINEER



PUBLICATION DATE: 3/1/2021 REVISION DATE: 2/10/2021

**COMBINATION INLET**

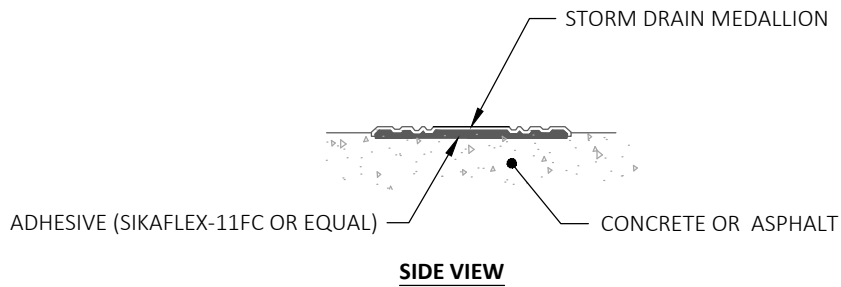
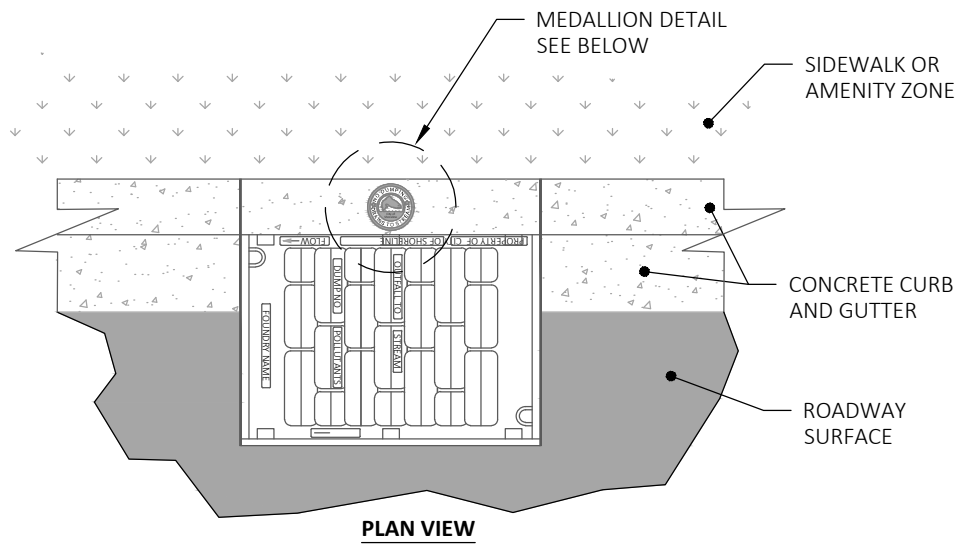

**TOP VIEW**

NOTE:

1. CLEAN MOUNTING SURFACE USING WIRE BRUSH. BLOW ALL DUST AND DEBRIS FROM MOUNTING AREA.
2. APPLY ADHESIVE TO BACK OF MEDALLION.
3. PLACE MEDALLION ON TOP SURFACE OF CURB OR AS DIRECTED BY ENGINEER.
4. ENSURE MEDALLION IS SEATED INTO ADHESIVE BY APPLYING PRESSURE AS REQUIRED.
5. MEDALLION IS REQUIRED FOR DRAINS ON-SITE AND IN THE RIGHT-OF-WAY.

*Tricia Juhnke*

APPROVED BY: TRICIA JUHNKE  
CITY ENGINEER



STANDARD DETAIL NUMBER: **725** SCALE: **NOT TO SCALE**

**STORM DRAIN MEDALLION**

PUBLICATION DATE: 3/1/2021 REVISION DATE: 2/11/2020

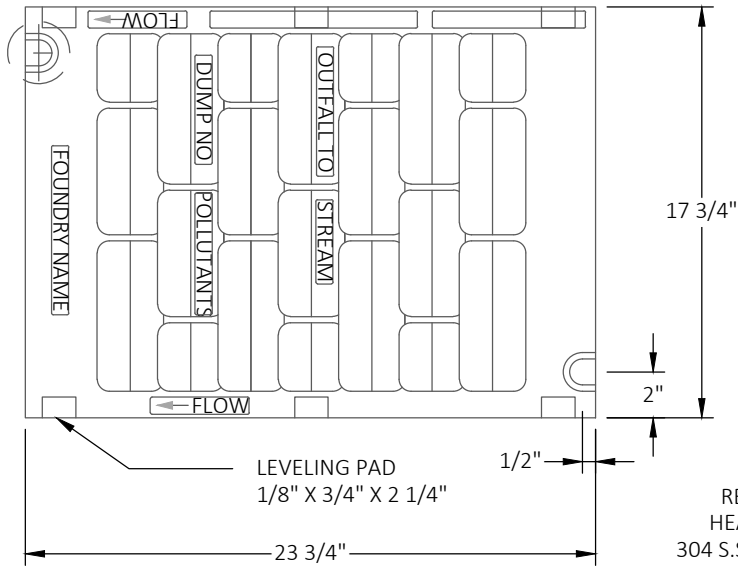

**PLAN**

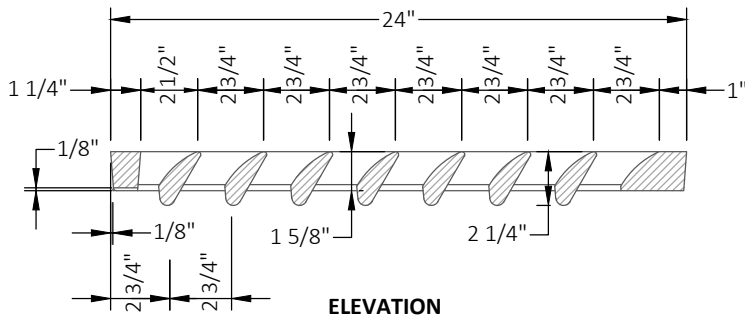

**ELEVATION**

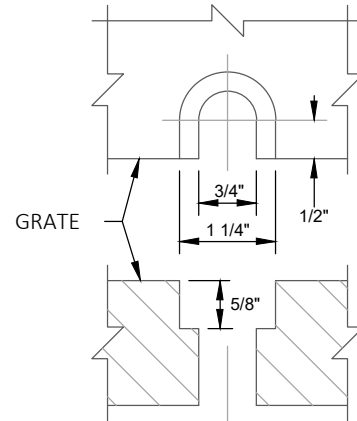

**SLOT**

RECESSED ALLEN  
HEAD CAP SCREW  
304 S.S. 5/8" (IN) - 11  
NC x 2" (IN)

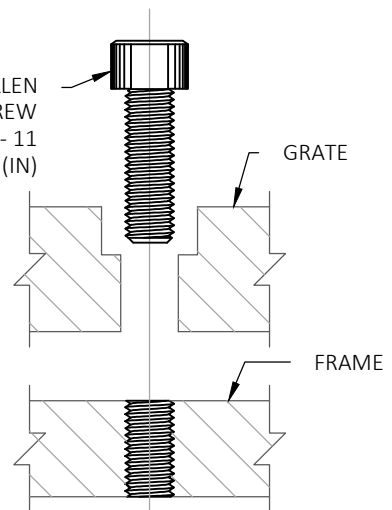

**HOLE**

**BOLT-DOWN DETAILS  
SEE NOTE 1**

**NOTES:**

1. BOLT-DOWN CAPABILITY IS REQUIRED ON ALL FRAMES, GRATES, AND COVERS, UNLESS SPECIFIED OTHERWISE IN THE CONTRACT. PROVIDE 2 HOLES IN THE FRAME THAT ARE VERTICALLY ALIGNED WITH THE GRATE OR COVER SLOTS. THE FRAME SHALL ACCEPT THE 304 STAINLESS STEEL (S.S.) 5/8" (IN) - 11 NC x 2" (IN) ALLEN HEAD CAP SCREW BY BEING TAPPED, OR OTHER APPROVED MECHANISM. LOCATION OF BOLT-DOWN HOLES VARIES BY MANUFACTURER.
2. REFER TO STANDARD SPECIFICATION SECTION 9-05.15 AND 9-05.15(2) FOR ADDITIONAL REQUIREMENTS.
3. FOR FRAME DETAILS, COS STD 730.

*Tricia Juhnke*

APPROVED BY: TRICIA JUHNKE  
CITY ENGINEER



STANDARD DETAIL NUMBER: **726** SCALE: **NOT TO SCALE**

**RECTANGULAR VANED GRATE**

PUBLICATION DATE: 3/1/2021 REVISION DATE: 2/10/2021

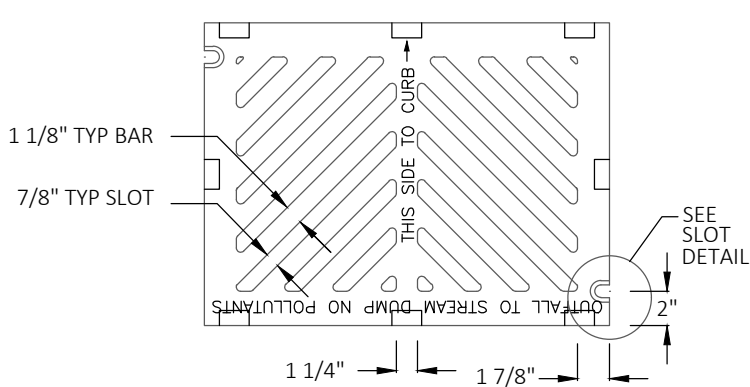

**TOP VIEW**

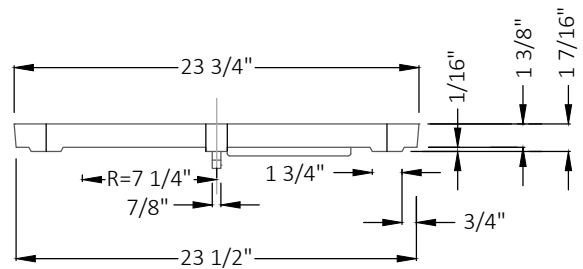

**SIDE VIEW**

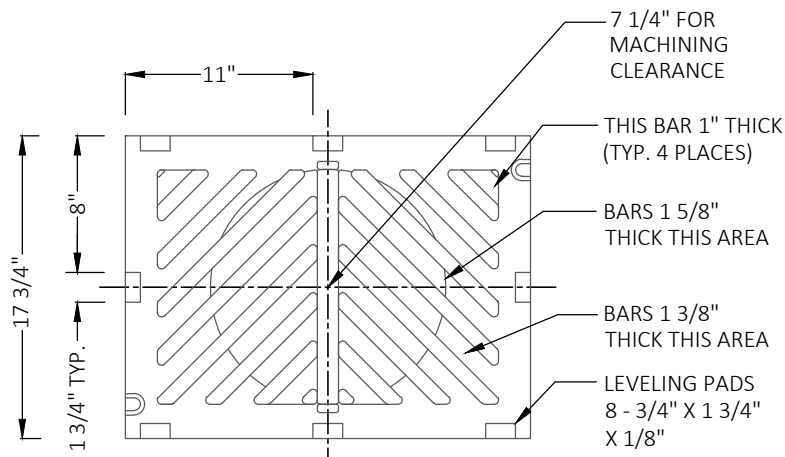

**BOTTOM VIEW**

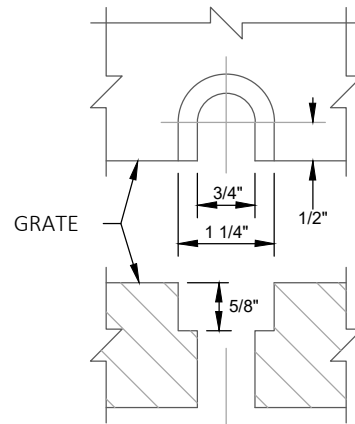

**SLOT**

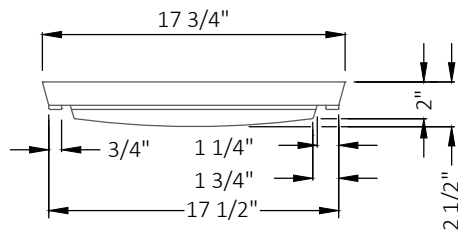

**END VIEW**

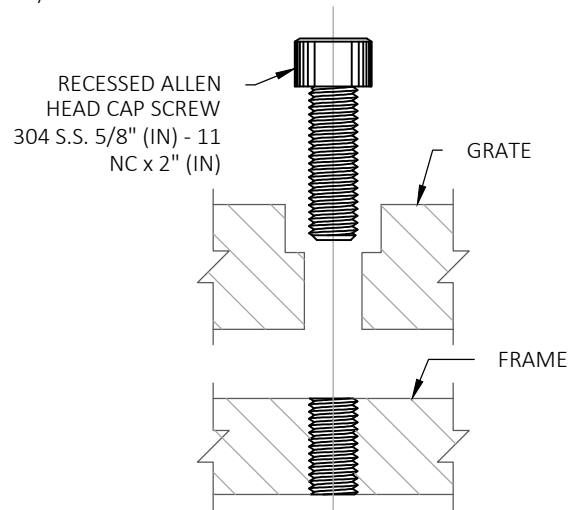

**HOLE  
BOLT-DOWN DETAILS  
SEE NOTE 1**

**NOTES:**

1. BOLT-DOWN CAPABILITY IS REQUIRED ON ALL FRAMES, GRATES, AND COVERS, UNLESS SPECIFIED OTHERWISE IN THE CONTRACT. PROVIDE 2 HOLES IN THE FRAME THAT ARE VERTICALLY ALIGNED WITH THE GRATE OR COVER SLOTS. THE FRAME SHALL ACCEPT THE 304 STAINLESS STEEL (S.S.) 5/8" (IN) - 11 NC x 2" (IN) ALLEN HEAD CAP SCREW BY BEING TAPPED, OR OTHER APPROVED MECHANISM. LOCATION OF BOLT-DOWN HOLES VARIES BY MANUFACTURER.
3. REFER TO STANDARD SPECIFICATION SECTION 9-05.15 AND 9-05.15(2) FOR ADDITIONAL REQUIREMENTS.
4. FOR FRAME DETAILS, COS STD 730.

*Tricia Juhnke*

APPROVED BY: TRICIA JUHNKE  
CITY ENGINEER



STANDARD DETAIL NUMBER: **729** SCALE: **NOT TO SCALE**

**RECTANGULAR  
HERRINGBONE GRATE**

PUBLICATION DATE: 3/1/2021 REVISION DATE: 2/10/2021

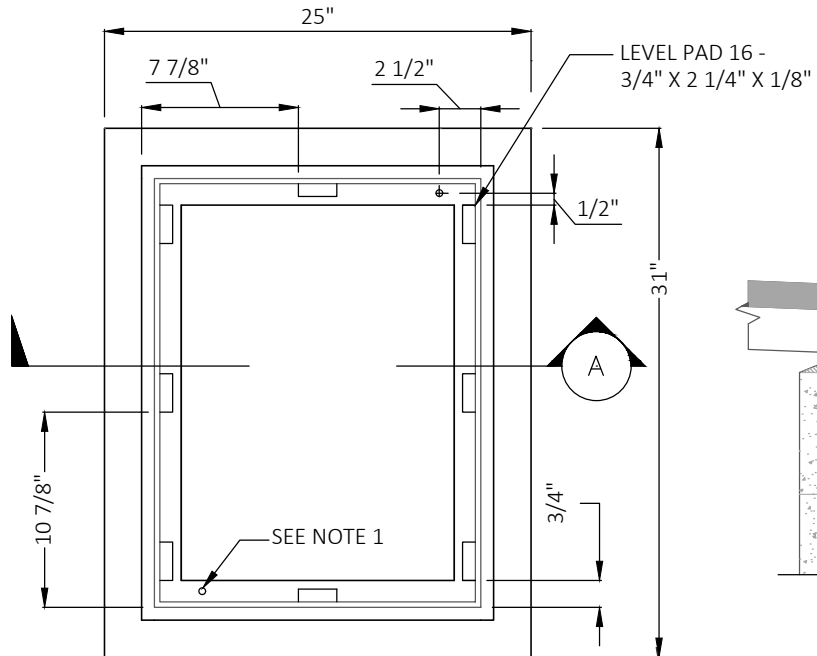

**PLAN**

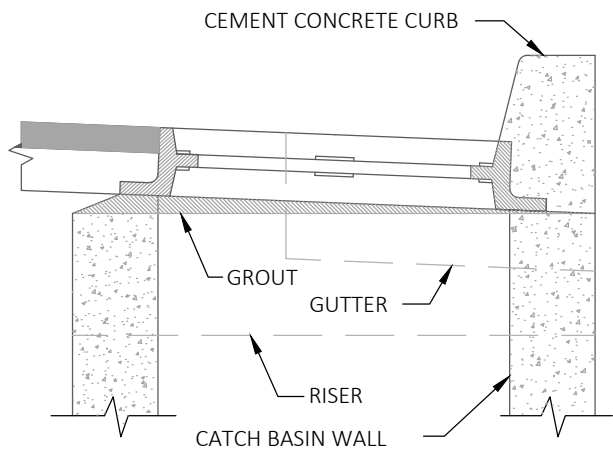

**VERTICAL CURB**

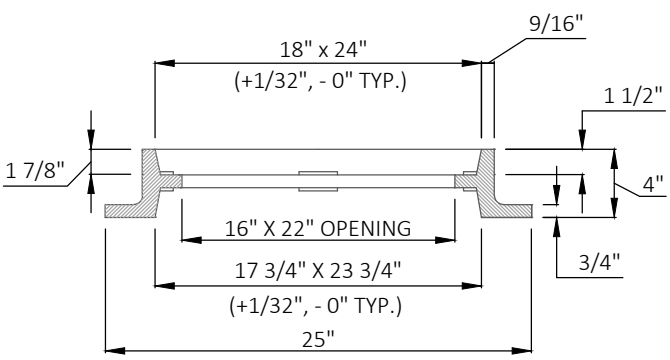

**SECTION A**

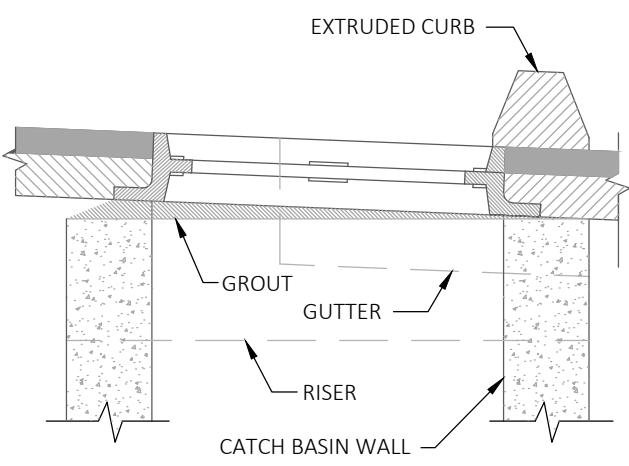

**EXTRUDED CURB**

**NOTES:**

1. SEE COS STD 726, 729, AND 731 FOR BOLT-DOWN DETAILS.
2. REFER TO STANDARD SPECIFICATION SECTION 9-05.15 AND 9-05.15(2) FOR ADDITIONAL REQUIREMENTS.

*Tricia Juhnke*

APPROVED BY: TRICIA JUHNKE  
CITY ENGINEER



STANDARD DETAIL NUMBER: **730** SCALE: **NOT TO SCALE**

**RECTANGULAR FRAME**

PUBLICATION DATE: 3/1/2021 REVISION DATE: 2/10/2021

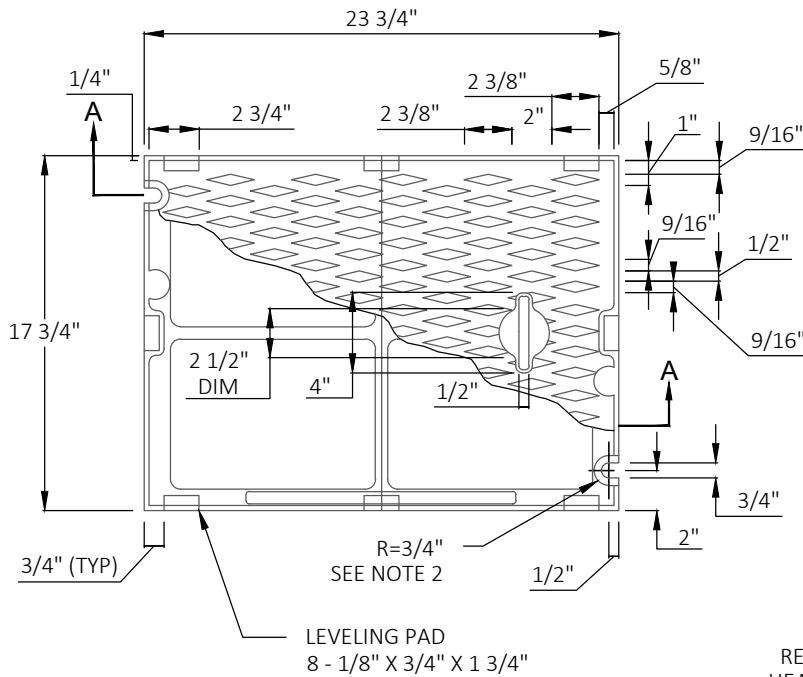

**PLAN**

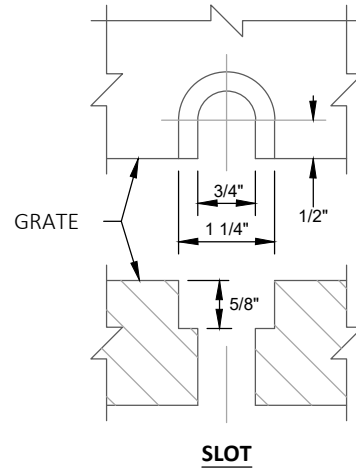

**SLOT**

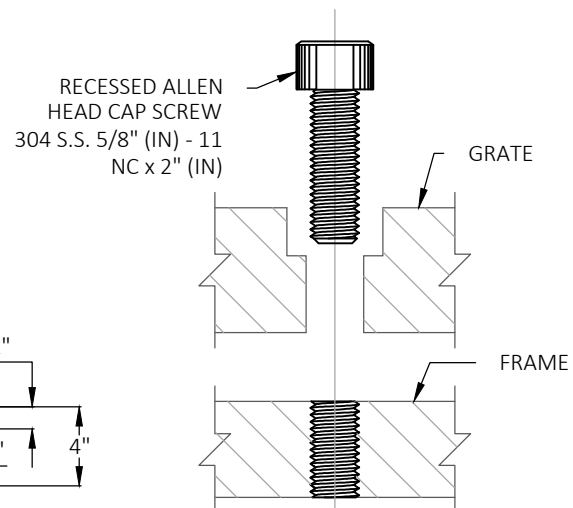

**HOLE  
BOLT-DOWN DETAILS  
SEE NOTE 1**

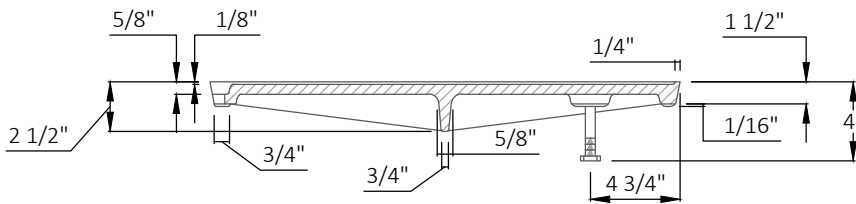

**SECTION A-A**

**NOTES:**

1. BOLT-DOWN CAPABILITY IS REQUIRED ON ALL FRAMES, GRATES, AND COVERS, UNLESS SPECIFIED OTHERWISE IN THE CONTRACT. PROVIDE 2 HOLES IN THE FRAME THAT ARE VERTICALLY ALIGNED WITH THE GRATE OR COVER SLOTS. THE FRAME SHALL ACCEPT THE 304 STAINLESS STEEL (S.S.) 5/8" (IN) - 11 NC x 2" (IN) ALLEN HEAD CAP SCREW BY BEING TAPPED, OR OTHER APPROVED MECHANISM. LOCATION OF BOLT-DOWN HOLES VARIES BY MANUFACTURER.
4. ALTERNATIVE REINFORCING DESIGNS ARE ACCEPTABLE IN LIEU OF THE RIB DESIGN.
5. REFER TO STANDARD SPECIFICATION SECTION 9-05.15 AND 9-05.15(2) FOR ADDITIONAL REQUIREMENTS.
6. FOR FRAME DETAILS, SEE COS STD 730.

*Tricia Juhnke*

APPROVED BY: TRICIA JUHNKE  
CITY ENGINEER



STANDARD DETAIL NUMBER: **731** SCALE: **NOT TO SCALE**

**RECTANGULAR SOLID METAL COVER**

PUBLICATION DATE: 3/1/2021 REVISION DATE: 2/10/2021

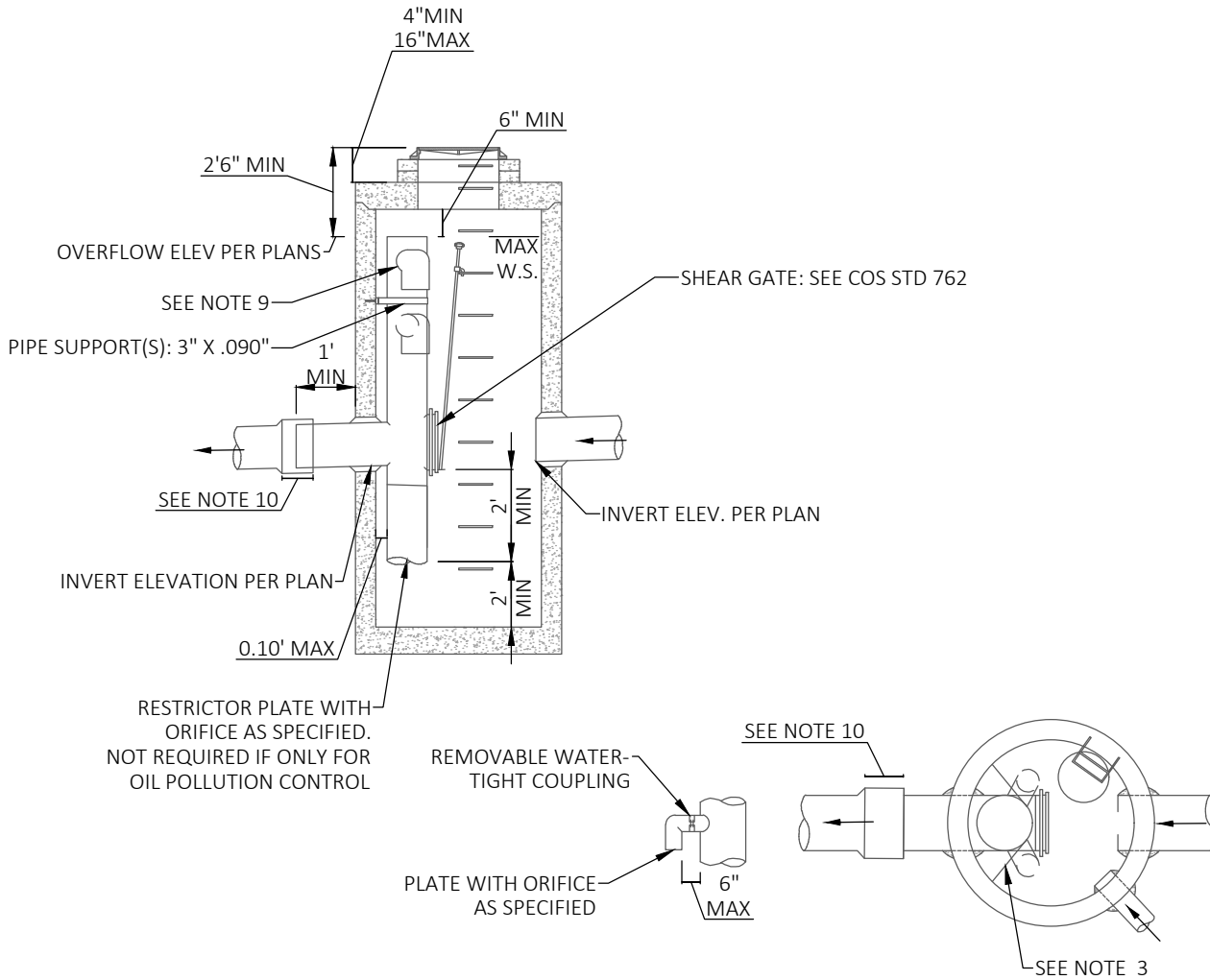

**NOTES:**

1. PIPE SIZES AND SLOPES: PER PLANS.
2. EXCEPT AS SHOWN OR NOTED, UNITS SHALL BE CONSTRUCTED IN ACCORDANCE WITH THE REQUIREMENTS FOR CATCH BASIN TYPE 2, 54" MIN DIA.
3. PIPE SUPPORTS SHALL BE STAINLESS STEEL, AND BE ANCHORED AT 3' MAX. SPACING BY 5/8" DIA STAINLESS STEEL EXPANSION BOLTS OR EMBEDDED 2" IN WALL. ONE STRAP ABOVE AND BELOW OUTLET REQUIRED, INTERMEDIATE STRAPS REQUIRED FOR RESTRICTOR RISERS GREATER THAN 12' ABOVE OUTLET.
4. THE RESTRICTOR/SEPARATOR SHALL BE FABRICATED FROM .060" ALUMINUM, OR .064" ALUMINIZED STEEL.
5. OUTLET SHALL BE CONNECTED TO CULVERT OR STORM DRAIN WITH A STANDARD COUPLING BAND FOR CORRUGATED METAL PIPE, OR GROUTED INTO THE BELL OF CONCRETE PIPE.
6. THE VERTICAL RISER STEM OF THE RESTRICTOR/SEPARATOR SHALL BE THE SAME DIA AS THE HORIZONTAL OUTLET PIPE, WITH AN 8" MIN. DIA.
9. IF METAL OUTLET PIPE CONNECTS TO CEMENT CONCRETE PIPE: OUTLET PIPE TO HAVE SMOOTH O.D. EQUAL TO CONCRETE PIPE I.D. LESS 1/4".
10. MULTI-ORIFICE ELBOWS MAY BE LOCATED AS SHOWN OR ALL ON ONE SIDE OF RISER TO ASSURE LADDER CLEARANCE.
11. BAND STRAP WITH GASKET.

**ELBOW DETAIL**

**PLAN**

*Tricia Juhnke*

APPROVED BY: TRICIA JUHNKE  
CITY ENGINEER



STANDARD DETAIL NUMBER: **761** SCALE: **NOT TO SCALE**

**FLOW RESTRICTOR**

PUBLICATION DATE: 3/1/2021 REVISION DATE: 2/11/2020



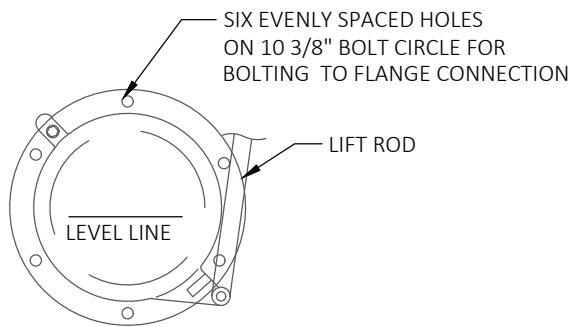

**FRONT  
(CLOSED POSITION)**

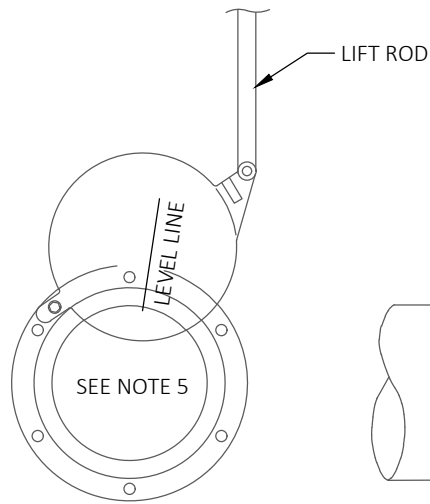

**MAXIMUM OPENING OF GATE**

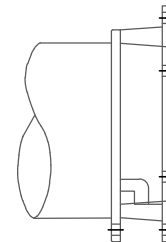

**SIDE**

LIFT HANDLE SHALL BE ATTACHED PER MANUFACTURER'S RECOMMENDATIONS

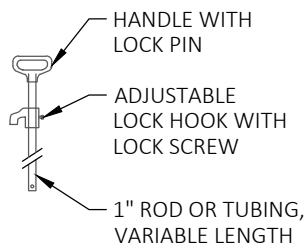

**LIFT HANDLE**

**NOTES:**

1. SHEAR GATE SHALL BE ALUMINUM ALLOY PER ASTM B-26-ZG-32a OR CAST IRON ASTM A48 CLASS 308 AS REQUIRED.
2. GATE SHALL BE 8" DIAMETER UNLESS OTHERWISE SPECIFIED.
3. GATE SHALL BE JOINED TO TEE SECTION BY BOLTING (THROUGH FLANGE) OR WELDED.
4. LIFT ROD: AS SPECIFIED BY MANUFACTURER WITH HANDLE EXTENDING TO WITHIN 1 FOOT OF COVER & ADJUSTABLE HOOK LOCK FASTENED TO FRAME OR UPPER HANDHOLD.
5. GATE SHALL NOT OPEN BEYOND THE CLEAR OPENING BY LIMITED HINGE MOVEMENT, STOP TAB, OR SOME OTHER DEVICE.
6. NEOPRENE RUBBER GASKET REQUIRED BETWEEN RISER MOUNTING FLANGE AND GATE FLANGE.
7. MATING SURFACES OF LID AND BODY TO BE MACHINED FOR PROPER FIT.
8. FLANGE MOUNTING BOLTS SHALL BE 3/8" DIAMETER STAINLESS STEEL.
9. ALTERNATIVE CLEANOUT/SHEAR GATES TO THE DESIGN SHOWN ARE ACCEPTABLE, PROVIDED THEY MEET THE MATERIAL SPECIFICATIONS ABOVE AND HAVE A SIX BOLT, 10 3/8" BOLT CIRCLE FOR BOLTING TO THE FLANGE CONNECTION.

*Tricia Juhnke*

APPROVED BY: TRICIA JUHNKE  
CITY ENGINEER



STANDARD DETAIL NUMBER: **762**

SCALE: **NOT TO SCALE**

**SHEAR GATE**

PUBLICATION DATE: 3/1/2021

REVISION DATE: 2/11/2020

Public Works

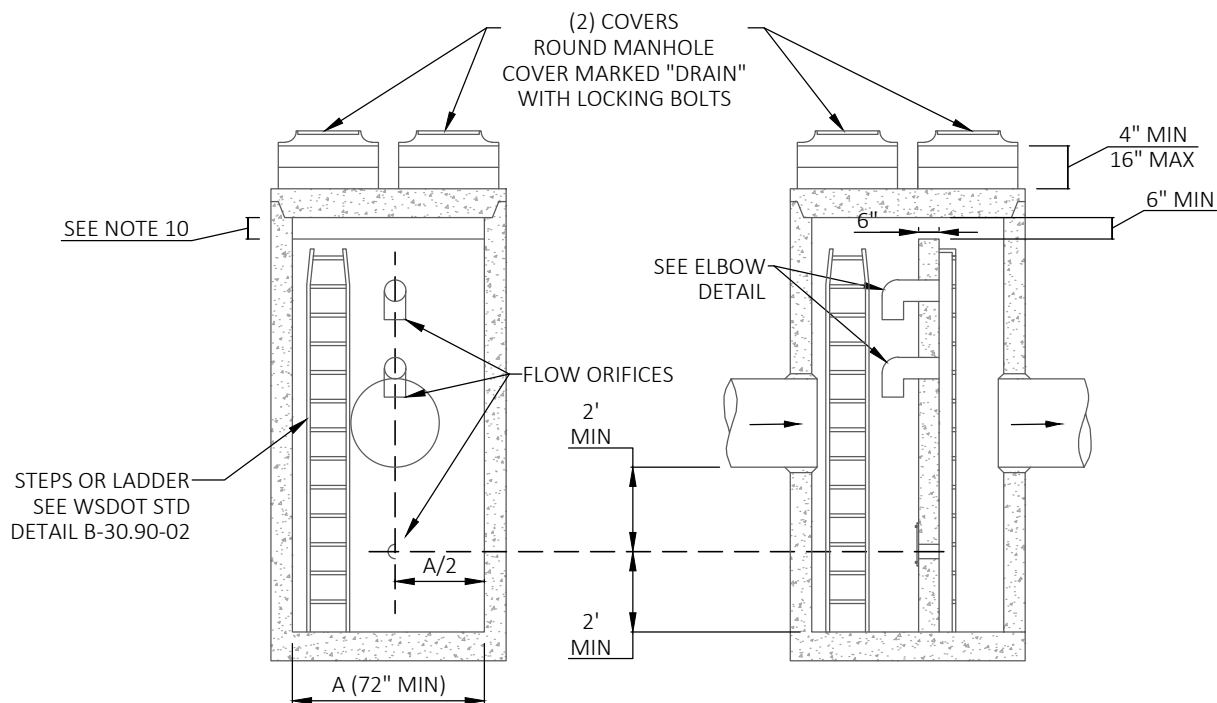

SECTION A-A

SECTION B-B

**ELEVATION**

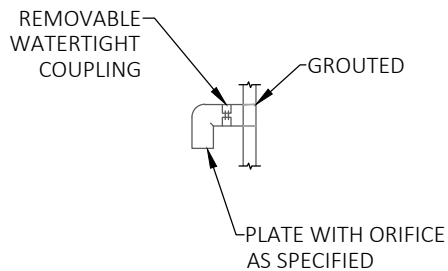

**ELBOW DETAIL**

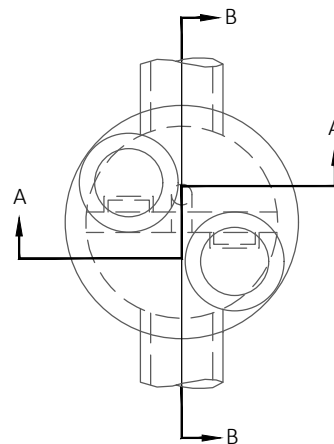

**PLAN**

**NOTES:**

1. PIPE SIZE, SLOPES, AND ALL ELEVATIONS: PER PLANS.
2. OUTLET CAPACITY: NOT LESS THAN COMBINED INLETS.
3. CATCH BASIN: TYPE 2 TO BE CONSTRUCTED IN ACCORDANCE WITH WSDOT STD DETAIL B-10.20-02& AASHTO M199 UNLESS OTHERWISE SPECIFIED.
4. COVERS: ROUND, SOLID MARKED "DRAIN" WITH LOCKING BOLTS. SEE WSDOT STD DETAIL B-30.70-04.
5. ORIFICES: SIZED & LOCATED AS REQUIRED, WITH LOWEST ORIFICE MIN 2" FROM BASE.
6. BAFFLE WALL SHALL HAVE #4 REINFORCEMENT BAR AT 12" SPACING EACH WAY.
7. PRECAST BAFFLE WALL SHALL BE KEYPED & GROUTED IN PLACE.
8. BOTTOM ORIFICE PLATE TO BE 1/4" MIN ALUMINUM & ATTACHED WITH 1/2" STAINLESS STEEL BOLTS. OMIT ORIFICE PLATE ID ONLY FOR OIL SEPARATION.
9. THE RESTRICTOR/SEPARATOR SHALL BE FABRICATED FROM .060" ALUMINUM.

*Tricia Juhnke*

APPROVED BY: TRICIA JUHNKE  
CITY ENGINEER



STANDARD DETAIL NUMBER: **763** SCALE: **NOT TO SCALE**

**FLOW RESTRICTOR (BAFFLE)**

PUBLICATION DATE: 3/1/2021 REVISION DATE: 2/11/2020

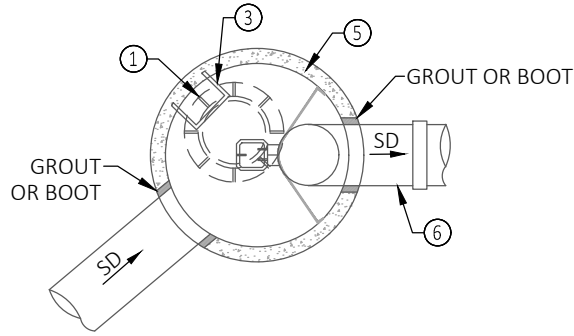

**PLAN**

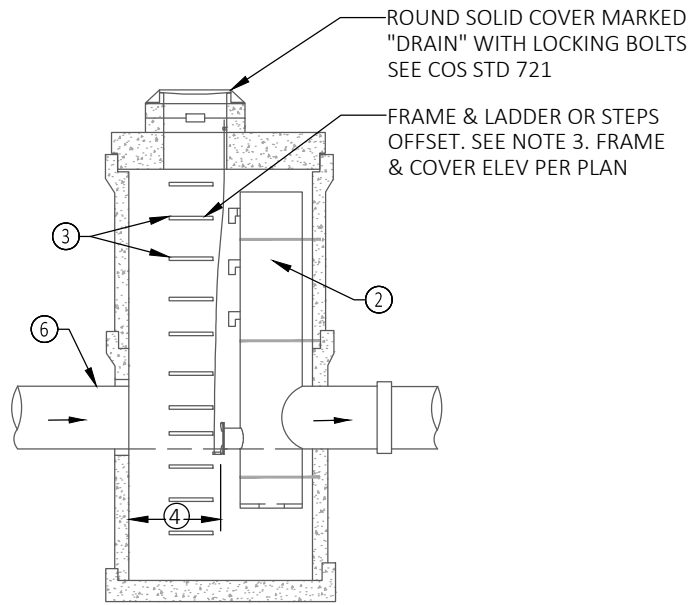

**ELEVATION**

**NOTES:**

- ① INSTALL 1-24" DIA MH ACCESS PER WSDOT STD DETAIL B-30.90-02, SO THAT THE LIFT GATE IS VISIBLE AND THE STEPS ARE CLEAR AND DIRECTLY ACCESSIBLE.
- ② FLOW RESTRICTOR UNIT - SEE COS STD 761.
- ③ POLYPROPLENE PLASTIC STEP OR LADDER, SEE WSDOT STD DETAIL B-30.90-02, OFFSET STEPS OR LADDER FROM FRAME SO THAT:
  - A. CLEANOUT GATE IS VISIBLE FROM TOP.
  - B. CLIMB DOWN SPACE IS CLEAR OF RISER AND CLEANOUT GATE.
  - C. FRAME IS CLEAR OF CURB.
- ④ MIN CLEARANCE: 36" FOR OUTLETS OF 24" AND LARGER 18" FOR OUTLETS OF 18" AND SMALLER.
- ⑤ 54" OR 60" TYPE 2 CB.
- ⑥ SEE PLAN AND SPECIFICATIONS FOR SIZE AND TYPE OF PIPES ENTERING AND EXITING CB.

*Tricia Juhnke*

APPROVED BY: TRICIA JUHNKE  
CITY ENGINEER



STANDARD DETAIL NUMBER: **771** SCALE: **NOT TO SCALE**

**CONTROL STRUCTURE**

PUBLICATION DATE: 3/1/2021 REVISION DATE: 2/11/2020

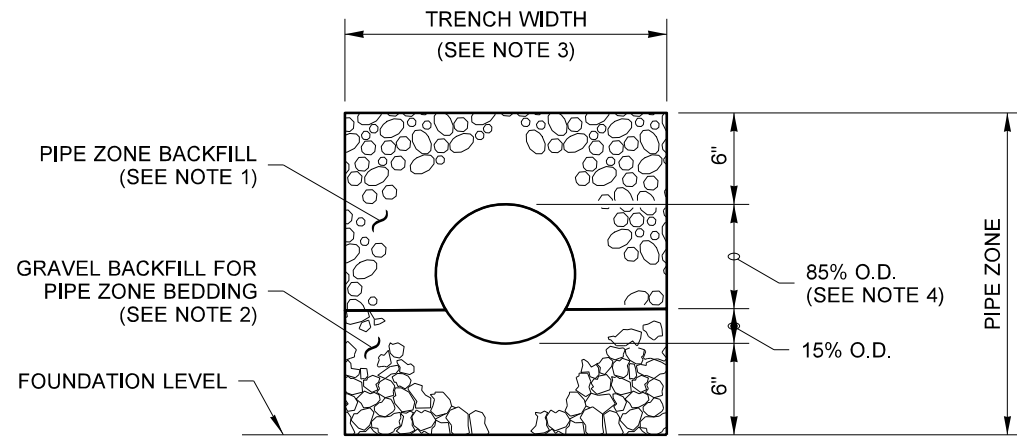

**CONCRETE AND DUCTILE IRON PIPE**

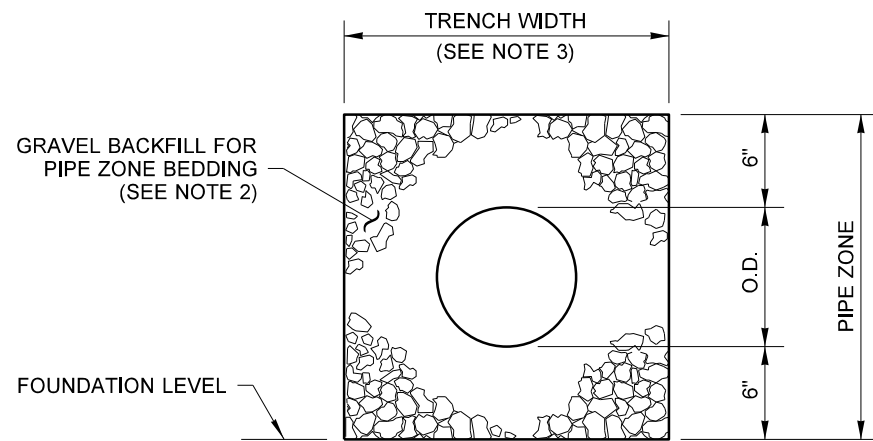

**THERMOPLASTIC PIPE**

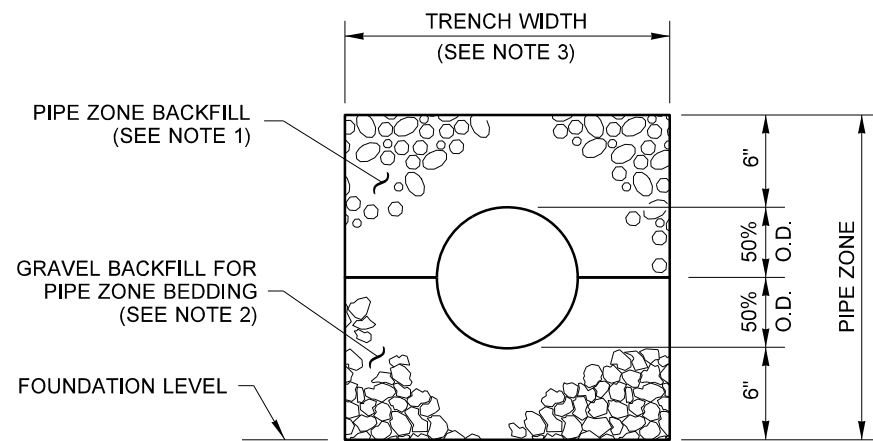

**METAL AND STEEL RIB REINFORCED POLYETHYLENE PIPE**

**NOTES**

1. See **Standard Specifications Section 7-08.3(3)** for Pipe Zone Backfill.
2. See **Standard Specifications Section 9-03.12(3)** for Gravel Backfill for Pipe Zone Bedding.
3. See **Standard Specifications Section 2-09.4** for Measurement of Trench Width.
4. For sanitary sewer installation, concrete pipe shall be bedded to spring line.

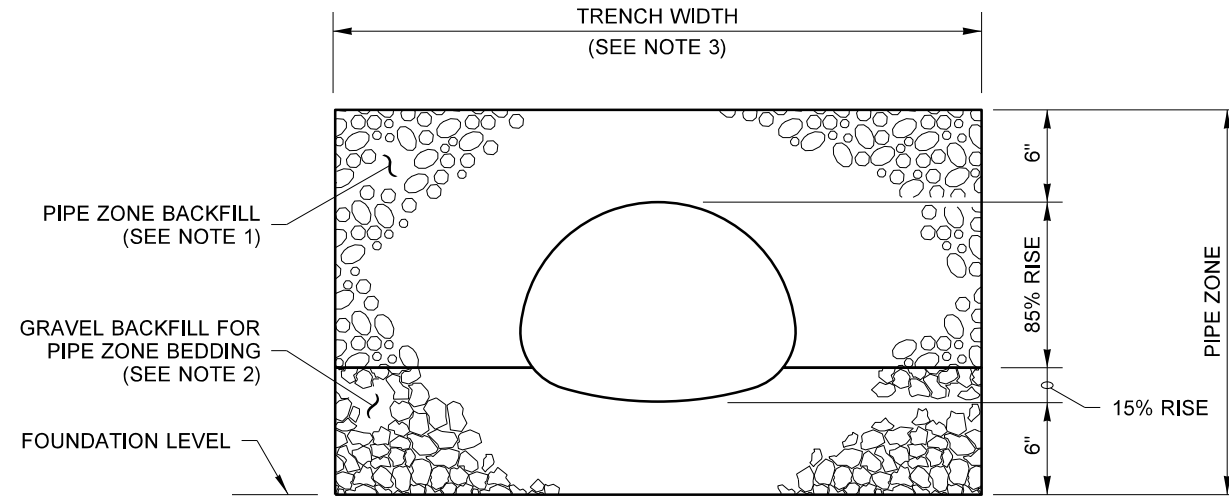

**PIPE ARCHES**

CLEARANCE BETWEEN PIPES FOR MULTIPLE INSTALLATIONS		
PIPE	SIZE	MINIMUM DISTANCE BETWEEN BARRELS
CIRCULAR PIPE (DIAMETER)	UP TO 48"	24"
METAL PIPE ARCH (SPAN)	48" AND LARGER	DIAMETER/2 OR 36" WHICHEVER IS LESS



Heilman, Julie  
Feb 20 2018 12:56 PM

**PIPE ZONE BEDDING AND BACKFILL**  
**STANDARD PLAN B-55.20-02**

SHEET 1 OF 1 SHEET

APPROVED FOR PUBLICATION

Carpenter, Jeff  
Feb 27 2018 8:01 AM

STATE DESIGN ENGINEER



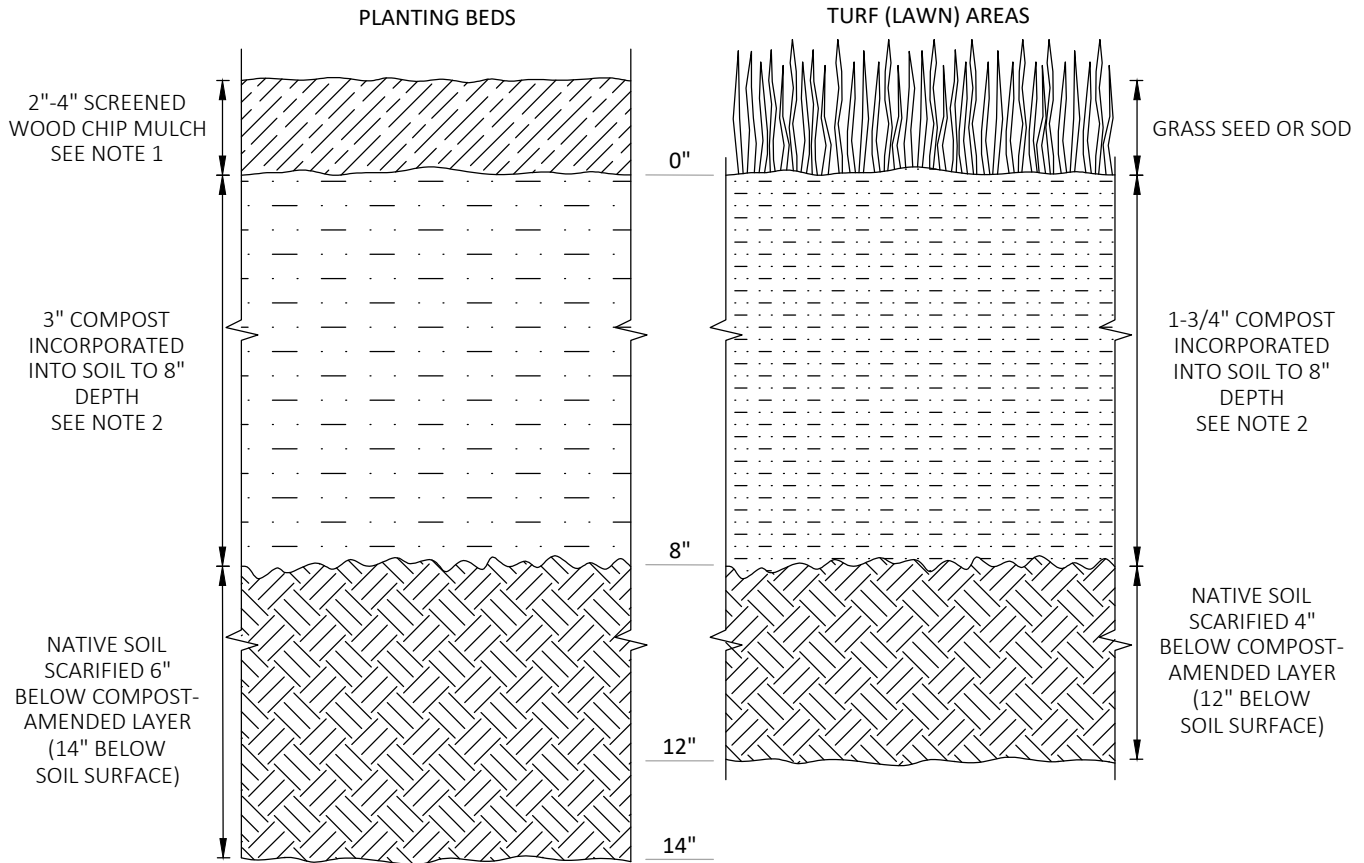

**SECTION VIEW**

**NOTES:**

1. WOOD CHIP MULCH SHALL MEET WSDOT STD SPEC 9-14.5(3).
2. COMPOST SHALL MEET WSDOT STD SPEC 9-14.5(8).
3. ALL SOIL AREAS DISTURBED OR COMPACTED DURING CONSTRUCTION AND NOT COVERED BY BUILDINGS OR PAVEMENT SHALL BE AMENDED WITH COMPOST TO A MINIMUM 8" DEPTH. SUBSOIL SHALL SCARIFIED 4" BELOW THAT COMPOST-AMENDED LAYER FOR A FINISHED 12" OF UN-COMPACTED DEPTH IN ALL LANDSCAPE AREAS.
4. COMPOST SHALL BE TILLED INTO 8" DEPTH INTO EXISTING SOIL, OR PLACE 8" OF COMPOST-AMENDED SOIL, PER SOIL SPECIFICATION. SUBSOIL SHALL BE SCARIFIED (LOOSENE) BELOW AMENDED LAYER TO PRODUCE OF UN-COMPACTED SOIL, EXCEPT WHERE SCARIFICATION WOULD DAMAGE TREE ROOTS.
5. TURF AREAS SHALL RECEIVE 1.75" OF COMPOST TILLED INTO 8" DEPTH, OR PLACE 8" OF IMPORTED SOIL CONTAINING 20-25% COMPOST BY VOLUME. THEN PLANT GRASS SEED OR SOD PER SPECIFICATIONS.
6. PLANTING BEDS SHALL RECEIVE 3" OF COMPOST TILLED INTO 8" DEPTH, OR PLACE 8" OF IMPORTED SOIL CONTAINING 35-40% COMPOST BY VOLUME. MULCH AFTER PLANTING, WITH 2-4" OF ARBORIST WOOD CHIP MULCH OR APPROVED EQUAL.
7. RAKE BEDS TO SMOOTH AND REMOVE SURFACE ROCKS LARGER THAN 2" DIAMETER.
8. DO NOT SCARIFY WITHIN DRIPLINE OF EXISTING TREES TO BE RETAINED OR WHERE SCARIFICATION WOULD DAMAGE TREE ROOTS. DO NOT COMPACT WITHIN TREE PROTECTION ZONES.
9. RECOMMENDED SEED MIX FOR HILLSIDES AND LOW-FOOT TRAFFIC AMENITY ZONES IS PT 702. FOR HIGHER FOOT-TRAFFIC AREAS, USE PT 755.

*Tricia Juhnke*

APPROVED BY: TRICIA JUHNKE  
CITY ENGINEER



STANDARD DETAIL NUMBER: **774** SCALE: **NOT TO SCALE**

**SOIL AMENDMENT AND DEPTH**

PUBLICATION DATE: 3/1/2021 REVISION DATE: 2/11/2020

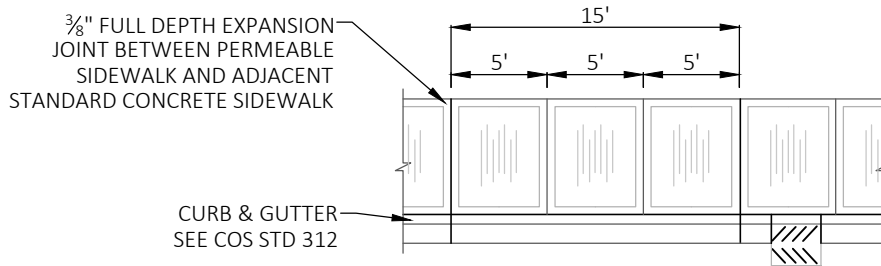

**PLAN VIEW - PERMEABLE SIDEWALK**

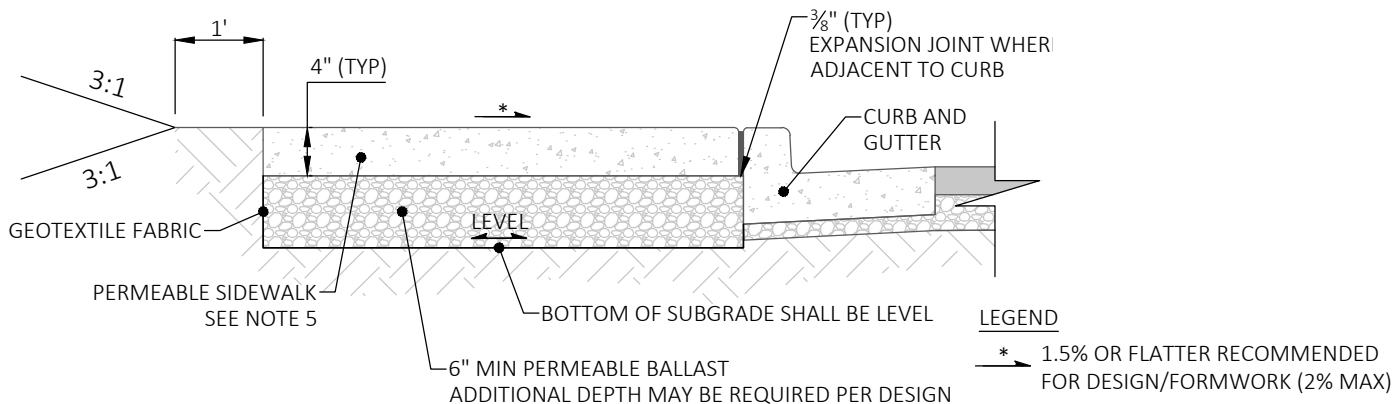

**PERMEABLE SIDEWALK SECTION**

**NOTES:**

1. REFER TO COS STD 309 FOR JOINT REQUIREMENTS.
2. SIDEWALK SHALL BE ADA COMPLIANT.
3. PERVIOUS CONCRETE SHALL BE INSTALLED BY A CERTIFIED PERVIOUS CONCRETE INSTALLER (NRMCA OR EQUIVALENT).
4. LIDS FOR JUNCTION BOXES AND UTILITY VAULTS SHALL BE NON-SKID, FLUSH WITH THE SURFACE, AND MATCH THE GRADE OF THE SIDEWALK.
5. CONCRETE SHALL CONFORM TO ALL REQUIREMENTS OF ACI 522.1-13 SPECIFICATION FOR PERVIOUS CONCRETE PAVEMENT. CONCRETE MIX SHALL MEET THE FOLLOWING:
  - a. 100% PASSING 3/8" SIEVE
  - b. WATER/CM RATION BETWEEN 0.28-0.35
  - c. MINIMUM INFILTRATION RATE OF 100 INCHES/HOUR PER ASTM C1701
6. PERMEABLE SIDEWALK SHALL BE TESTED PRIOR TO ACCEPTANCE. ONE TEST PER 2500 SF AREA MINIMUM. TESTING SHALL MEET ASTM C1701 AND SHALL MEET A MINIMUM RATE OF 100 INCHES/HOUR.
7. REMOVAL/REPLACEMENT OF PERMEABLE SIDEWALK SHALL BE FROM EXPANSION JOINT TO EXPANSION JOINT UNLESS OTHERWISE DIRECTED BY THE CITY ENGINEER.
8. PERMEABLE SIDEWALK SHALL BE PROTECTED FROM RUNOFF AND SEDIMENT UNTIL THE SIDEWALK IS CURED AND ALL ADJACENT AREAS ARE PERMANENTLY STABILIZED. CONSTRUCTION VEHICULAR TRAFFIC SHALL NOT BE ALLOWED ONTO THE PERMEABLE SIDEWALK. ALL PERMEABLE SURFACES SHALL BE VACUUMED IMMEDIATELY AFTER SAWCUTTING TO PREVENT CLOGGING.
9. PERMEABLE BALLAST SHALL BE CLEAN, ANGULAR ROCK CONFORMING TO WSDOT STANDARD SPECIFICATION 9-03.9(2).
10. GEOTEXTILE SHALL BE NONWOVEN, MODERATE SURVIVABILITY PER WSDOT STANDARD SPECIFICATION 9-33.2(1).
11. CHECK DAMS ARE REQUIRED ON LONGITUDINAL SUBGRADE SLOPES OF GREATER THAN 2%. SEE COS STD 776.
12. TO PREVENT COMPACTION, INSTALL THE AGGREGATE BASE IN THE FOLLOWING MANNER (BACK DUMPING):  
DUMP AGGREGATE BASE ONTO SUBGRADE FROM THE EDGE OF THE INSTALLATION, THEN PUSH IT OUT ONTO THE SUBGRADE. DUMP SUBSEQUENT LOADS FROM ON TOP OF THE AGGREGATE BASE AS THE INSTALLATION PROGRESSES.

*Tricia Juhnke*

APPROVED BY: TRICIA JUHNKE  
CITY ENGINEER



STANDARD DETAIL NUMBER: **775** SCALE: **NOT TO SCALE**

**PERMEABLE SIDEWALK**

PUBLICATION DATE: 3/1/2021 REVISION DATE: 2/11/2020

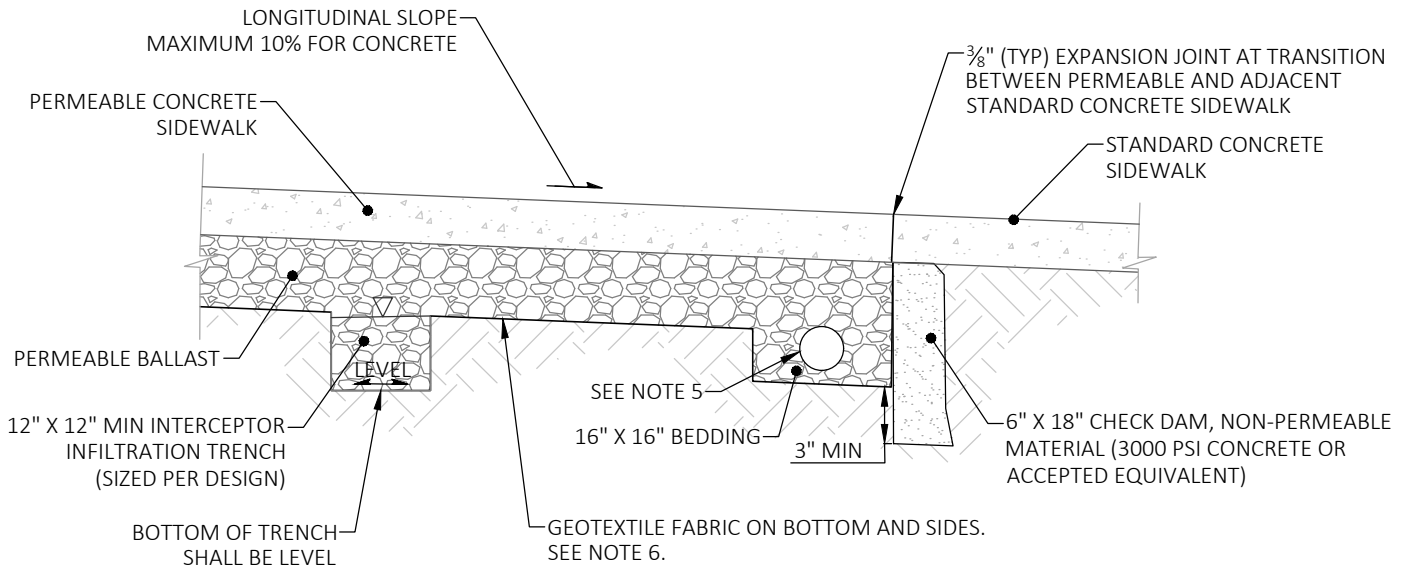

**PERMEABLE SIDEWALK INTERCEPTOR TRENCH**

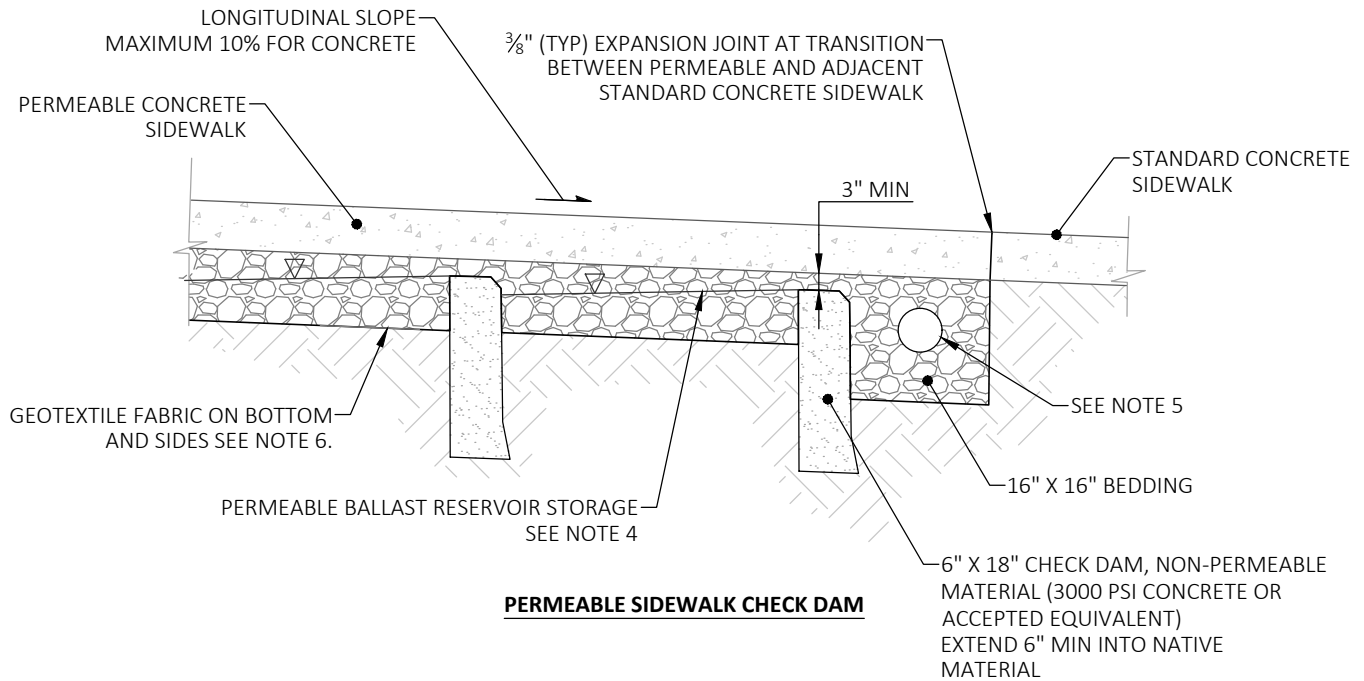

**PERMEABLE SIDEWALK CHECK DAM**

**NOTES:**

1. CHECK DAM OR INTERCEPTOR TRENCH REQUIRED FOR LONGITUDINAL SUBGRADE SLOPES >2%. TRANSVERSE SLOPE SHALL BE LEVEL.
2. SPACE CHECK DAMS BASED ON SLOPE TO ACHIEVE DESIGN AVERAGE PONDING DEPTH BEFORE OVERTOPPING DA.
3. REFER TO STD DETAIL FOR PERMEABLE SIDEWALK AND RESERVOIR DETAILS.
4. THE STORAGE VOLUME BETWEEN CHECK DAMS SHALL BE BASED ON CHECK DAM HEIGHT AND SPACING FOR MODELING. CHECK DAM HEIGHT AND SUBGRADE SLOPE SHALL BE SPECIFIED ON THE PLANS.
5. 6" PVC PERFORATED PIPE WITH CLEANOUTS AND CONNECTION TO STORM.
6. GEOTEXTILE SHALL BE NONWOVEN, MODERATE SURVIVABILITY PER WSDOT STANDARD SPECIFICATION 9-33.2(1).
7. SIDEWALK SHALL BE ADA COMPLIANT.

*Tricia Juhnke*

APPROVED BY: TRICIA JUHNKE  
CITY ENGINEER



STANDARD DETAIL NUMBER: **776** SCALE: **NOT TO SCALE**

**PERMEABLE SIDEWALK ON SLOPES**

PUBLICATION DATE: 3/1/2021 REVISION DATE: 2/11/2020

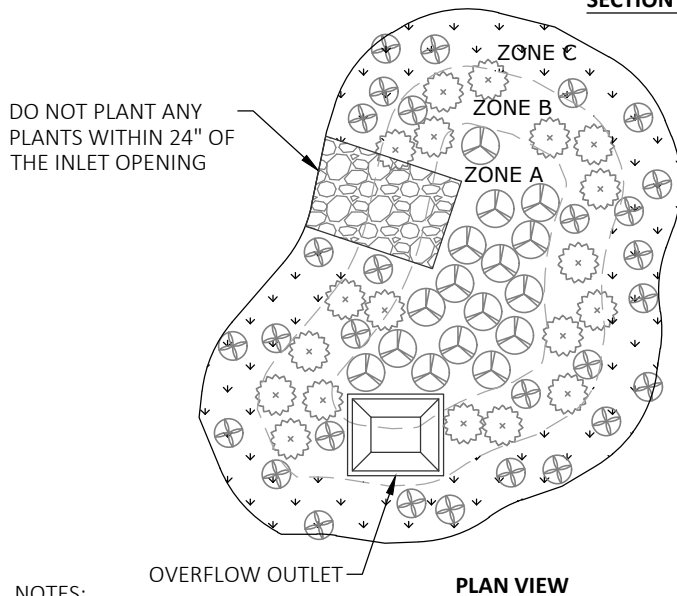
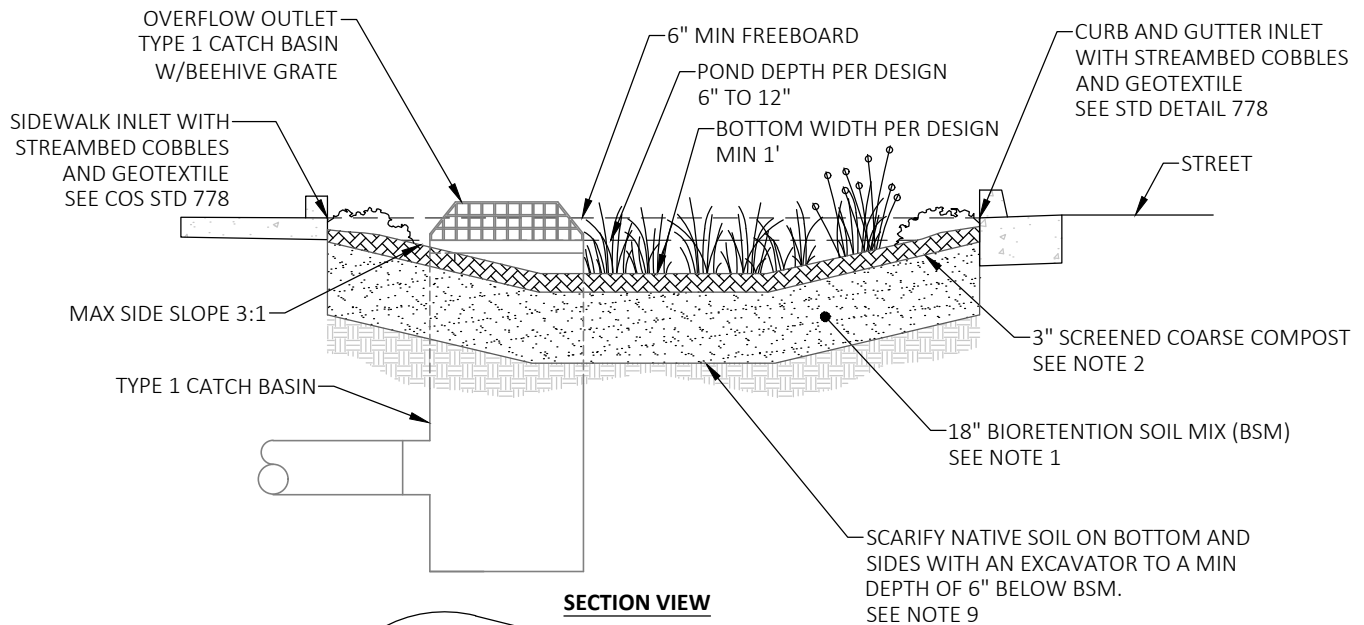

PLANTING ZONES:

- ZONE A: BOTTOM OF FACILITY, AREA WITH FREQUENT STANDING WATER
- ZONE B: LOWER SIDE SLOPE, AREA WITH OCCASIONAL STANDING WATER AND EXTENDED DRIER PERIOD.
- ZONE C: UPPER SIDE SLOPE, DRIEST PORTION OF THE FACILITY.

NOTES:

- REFER TO PLANS FOR BIORETENTION FACILITY SHAPE, PLANTINGS, ELEVATIONS, SURFACE AREA, CONFIGURATION, AND ADDITIONAL DESIGN FEATURES.
- BIORETENTION SOIL MIX (BSM) SHALL MEET WSDOT STANDARD SPEC. DO NOT COMPACT BSM.
- COARSE COMPOST SHALL MEET WSDOT STD SPEC 9-14.5(8).
- MAXIMUM BOTTOM SLOPE OF CELL IS 0.5%.
- OVERFLOW POINT SHALL BE AT LEAST 6 INCHES BELOW ANY ADJACENT PAVEMENT AREA.
- INSTALL 4" STREAMBED COBBLE AT INLET TO DISSIPATE RUNOFF. SEE COS STD 778.
- MINIMUM 3 FOOT DEPTH BETWEEN BOTTOM OF BSM AND WATER TABLE.
- MINIMUM SETBACK OF 5 FEET FROM TOP OF BIORETENTION CELL TO BUILDING STRUCTURES AND PROPERTY LINES. DO NOT LOCATE IMMEDIATELY UP SLOPE OF BUILDING STRUCTURES.
- AVOID COMPACTION OF NATIVE SOIL BELOW FACILITY DURING CONSTRUCTION. DO NOT OPERATE HEAVY EQUIPMENT WITHIN THE FACILITY FOOTPRINT. DO NOT PLACE OR AMEND BSM WHEN THE GROUND IS FROZEN OR WHEN THE SOIL IS EXCESSIVELY WET.
- FOR FACILITIES IN THE RIGHT-OF-WAY, REFER TO EDM APPENDIX K FOR APPROVED PLANTS IN EACH ZONE.

*Tricia Juhnke*

APPROVED BY: TRICIA JUHNKE  
CITY ENGINEER



STANDARD DETAIL NUMBER: **777** SCALE: **NOT TO SCALE**

**BIORETENTION FACILITY**

PUBLICATION DATE: 3/1/2021 REVISION DATE: 2/11/2020



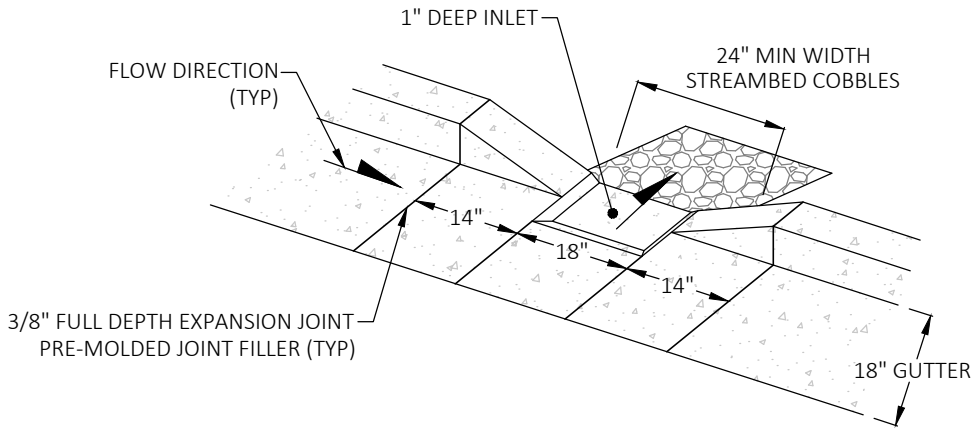

**CURB AND GUTTER INLET**

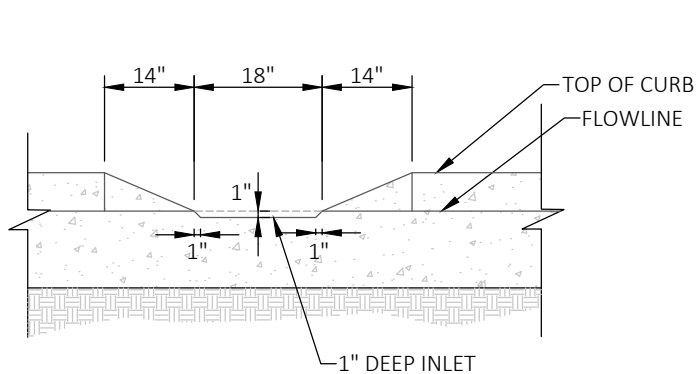

**FLOWLINE VIEW - CURB AND GUTTER INLET**

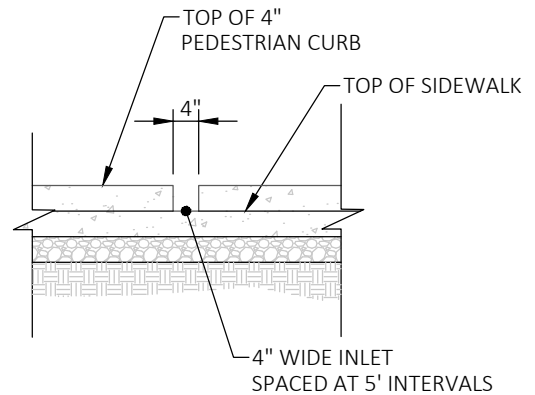

**FLOWLINE VIEW - SIDEWALK INLET**

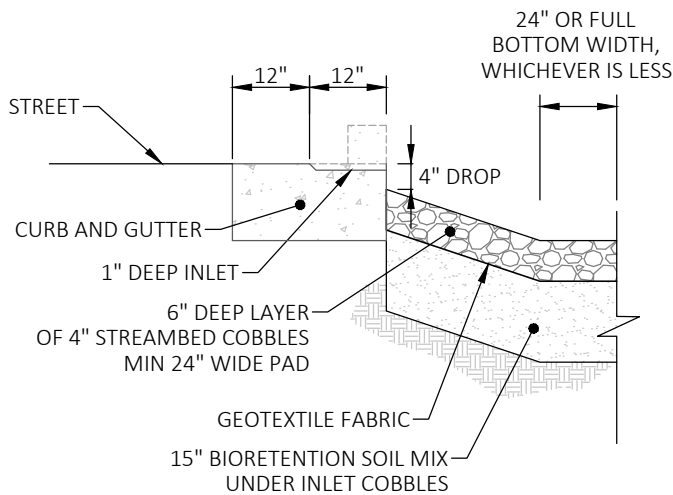

**SECTION VIEW - CURB AND GUTTER INLET**

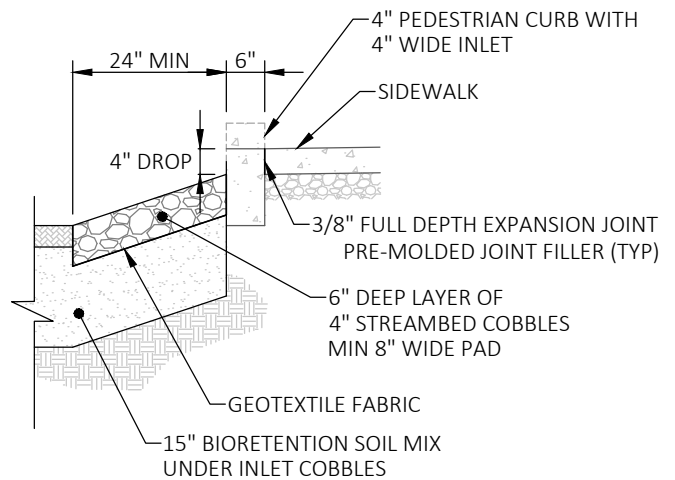

**SECTION VIEW - SIDEWALK INLET**

**NOTES:**

1. REFER TO COS STD 777 FOR BIORETENTION FACILITY DETAILS.
2. PROVIDE 4" MIN DROP FROM GUTTER OR SIDEWALK ELEVATION.
3. GEOTEXTILE SHALL BE NONWOVEN, MODERATE SURVIVABILITY PER WSDOT STANDARD SPECIFICATION 9-33.2(1).

*Tricia Juhnke*

APPROVED BY: TRICIA JUHNKE  
 CITY ENGINEER



STANDARD DETAIL NUMBER: **778** SCALE: **NOT TO SCALE**

**BIORETENTION INLET**

PUBLICATION DATE: 3/1/2021 REVISION DATE: 2/11/2020