

**NOTES**

1. The culvert ends shall be beveled to match the embankment or ditch slope and shall not be beveled flatter than 4H:1V. When slopes are between 4H:1V and 6H:1V, shape the slope in the vicinity of the culvert end to ensure that no part of the culvert protrudes more than 4" above the ground line.
2. Field cutting of culvert ends is permitted when approved by the Engineer. All field-cut culvert pipe shall be treated with treatment as shown in the Standard Specifications or General Special Provisions.

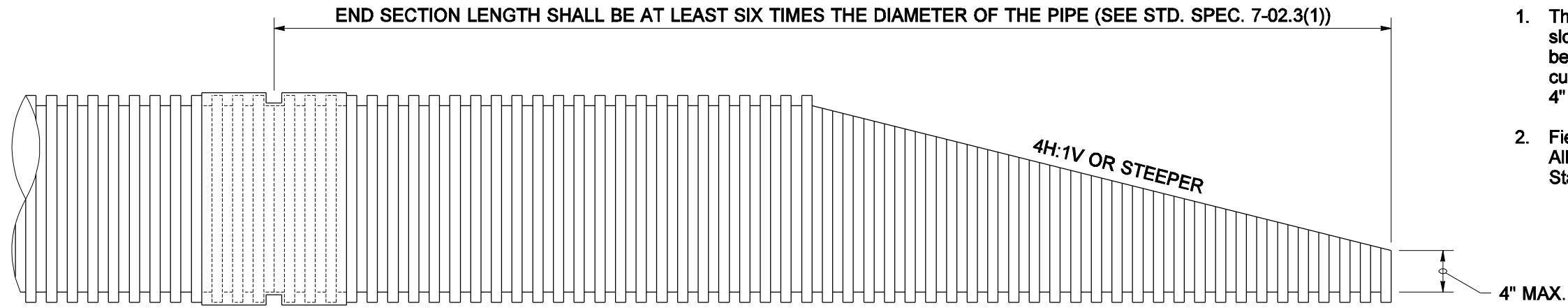

**THERMOPLASTIC PIPE**

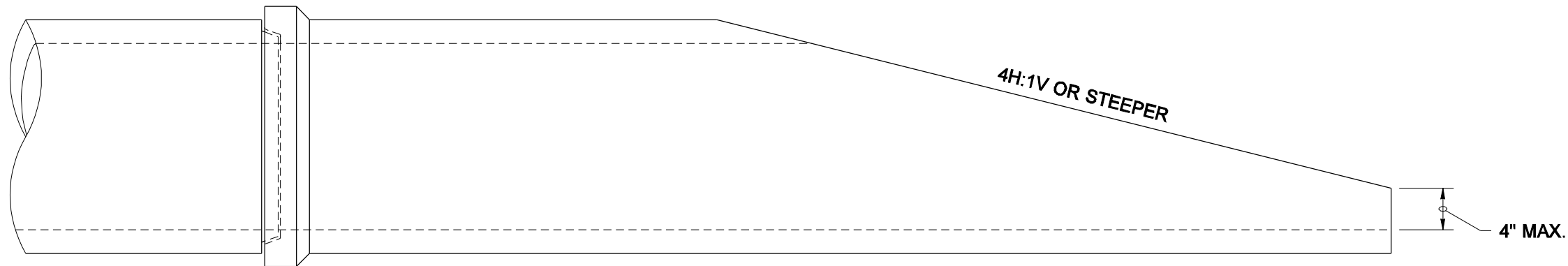

**CONCRETE PIPE**

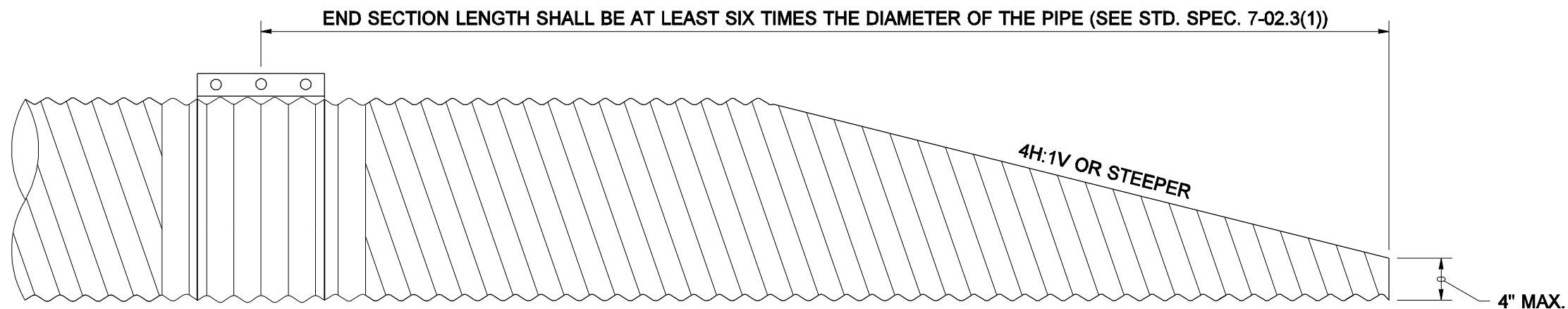

**METAL PIPE**

**FOR CULVERTS 30" DIAMETER OR LESS**



EXPIRES JULY 1, 2007

NOTE: THIS PLAN IS NOT A LEGAL ENGINEERING DOCUMENT BUT AN ELECTRONIC DUPLICATE. THE ORIGINAL, SIGNED BY THE ENGINEER AND APPROVED FOR PUBLICATION, IS KEPT ON FILE AT THE WASHINGTON STATE DEPARTMENT OF TRANSPORTATION. A COPY MAY BE OBTAINED UPON REQUEST.

**BEVELED END SECTIONS**  
**STANDARD PLAN B-70.20-00**  
 SHEET 1 OF 1 SHEET

APPROVED FOR PUBLICATION

**Harold J. Peterfeso** 06-01-06  
 STATE DESIGN ENGINEER DATE



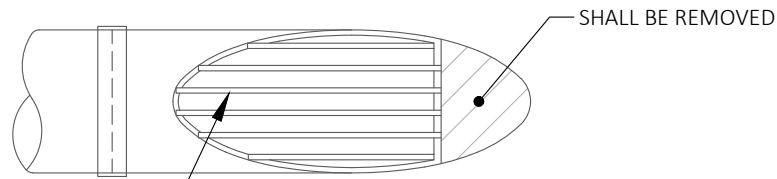

**PLAN VIEW**

3/4" DIA SMOOTH BARS WITH ENDS WELDED TO BAR-FRAME

1/4" X 2" FB ANCHOR STRIPS FASTENED WITH 1/2" NON-CORROSIVE BOLTS AND NUTS. (4 PLACES TYP)

4" CLR.

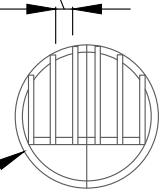

**END VIEW**

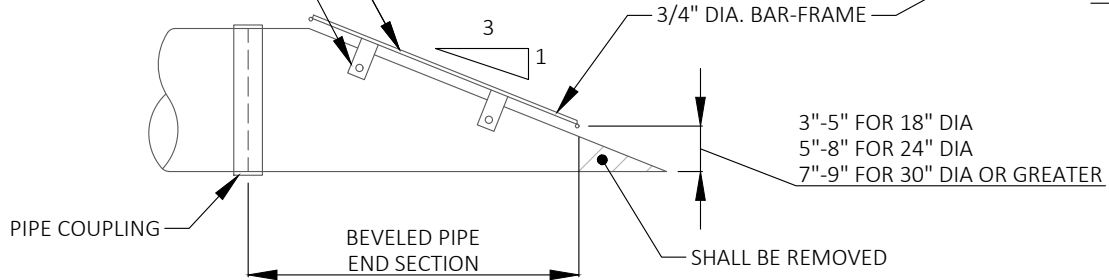

**SECTION VIEW**

**NOTES:**

1. CMP END-SECTION SHOWN. FOR CONCRETE PIPE BEVELED END-SECTION, SEE WSDOT STD B-70.20-00.
2. ALL PARTS MUST BE ALUMINUM OR STAINLESS STEEL.
3. TRASH RACKS REQUIRED ON ALL PIPES 18" AND LARGER IN DIAMETER OR AS DIRECTED BY ENGINEER.

*Tricia Juhnke*

APPROVED BY: TRICIA JUHNKE  
CITY ENGINEER



STANDARD DETAIL NUMBER: **702**

SCALE: **NOT TO SCALE**

**TRASH RACK**

PUBLICATION DATE: 03/01/2020 | REVISION DATE: 02/11/2020

3/4" DIAMETER SMOOTH BARS EQUALLY SPACED (4" O.C. MAX.)

4 HOOK CLAMPS EVENLY PLACED SEE DETAIL BELOW.

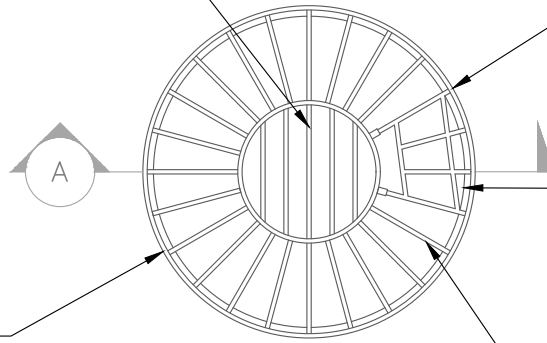

PROVIDE MAINTENANCE ACCESS BY WELDING 4 CROSSBARS TO 4 VERTICAL BARS AS SHOWN. HINGE UPPER ENDS WITH FLANGES/BOLTS AND PROVIDE LOCKING MECHANISM (PADLOCK) ON LOWER END. LOCATE STEPS DIRECTLY BELOW.

LOWER STEEL BAND 3/4"x 4" WIDE FORMED TO FIT IN GROOVE OF CB RISER

**PLAN VIEW**

UPPER STEEL BAND 3/4"x 4" WIDE

LOWER STEEL BAND 3/4"x 4" WIDE FORMED TO FIT IN GROOVE OF CB RISER

24" SEE NOTE 1

3/4" DIA. SMOOTH ROUND BARS WELDED TO UPPER AND LOWER BANDS. EQUALLY SPACED. BARS SHALL BE EVENLY SPACED (SEE NOTE 1)

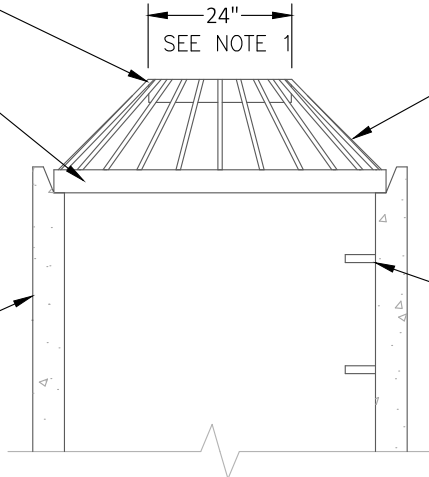

STANDARD LADDER

CB TYPE 2

**SECTION A**

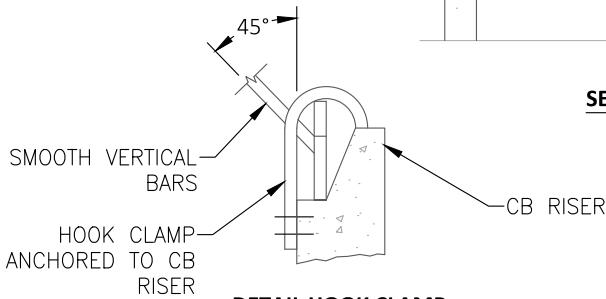

**DETAIL HOOK CLAMP**

NTS

**NOTES:**

1. DIMENSIONS ARE FOR ILLUSTRATION ON 54 IN. DIAMETER MH. FOR DIFFERENT DIAMETER MH'S, ADJUST TO MAINTAIN 45 DEGREE ANGLE ON "VERTICAL" BARS AND 7 IN. O.C. MAXIMUM SPACING OF BARS AROUND LOWER STEEL BAND.
- 2.
3. METAL PARTS MUST BE CORROSION RESISTANT. BARS MUST BE STAINLESS STEEL OR ALUMINIZED STEEL.
4. THIS DEBRIS BARRIER IS ALSO RECOMMENDED FOR USE ON THE INLET TO ROADWAY CROSS-CULVERTS WITH HEIGHT POTENTIAL FOR DEBRIS COLLECTION (EXCEPT ON TYPE 2 STREAMS)
5. USE OF THIS STRUCTURE WITHIN THE ROAD RIGHT-OF-WAY SHALL MEET THE MINIMUM CLEAR ZONE REQUIREMENTS.
6. SEE THE WSDOT/APWA STANDARD SPECIFICATIONS SECTION 9-05.15 FOR METAL CASTINGS REQUIREMENTS.

*Tricia Juhnke*

APPROVED BY: TRICIA JUHNKE  
CITY ENGINEER



STANDARD DETAIL NUMBER: **703** SCALE: **NOT TO SCALE**

**DEBRIS CAGE**

PUBLICATION DATE: 03/01/2020 REVISION DATE: 02/11/2020

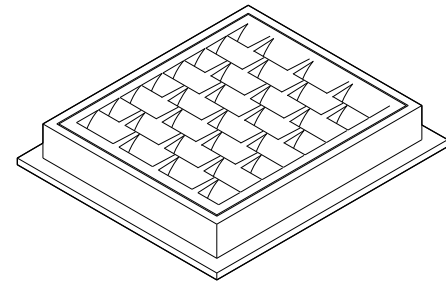

**FRAME AND VANED GRATE**

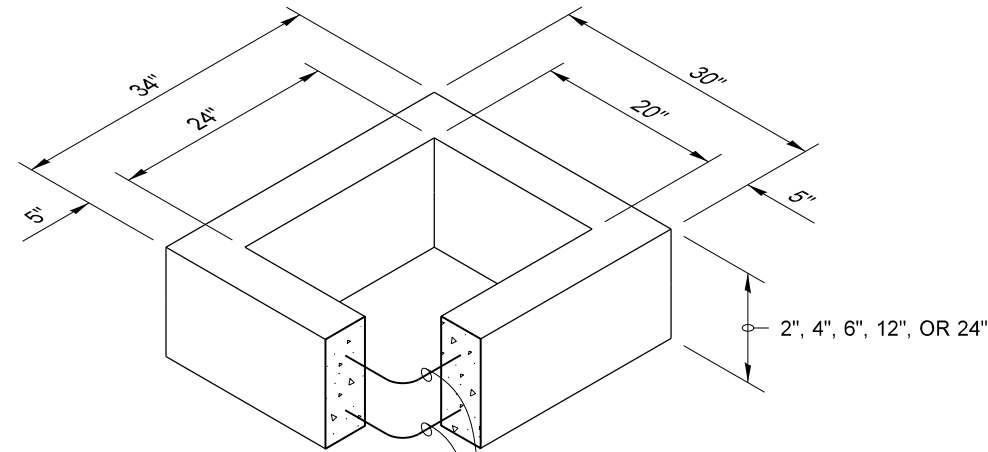

**RECTANGULAR ADJUSTMENT SECTION**

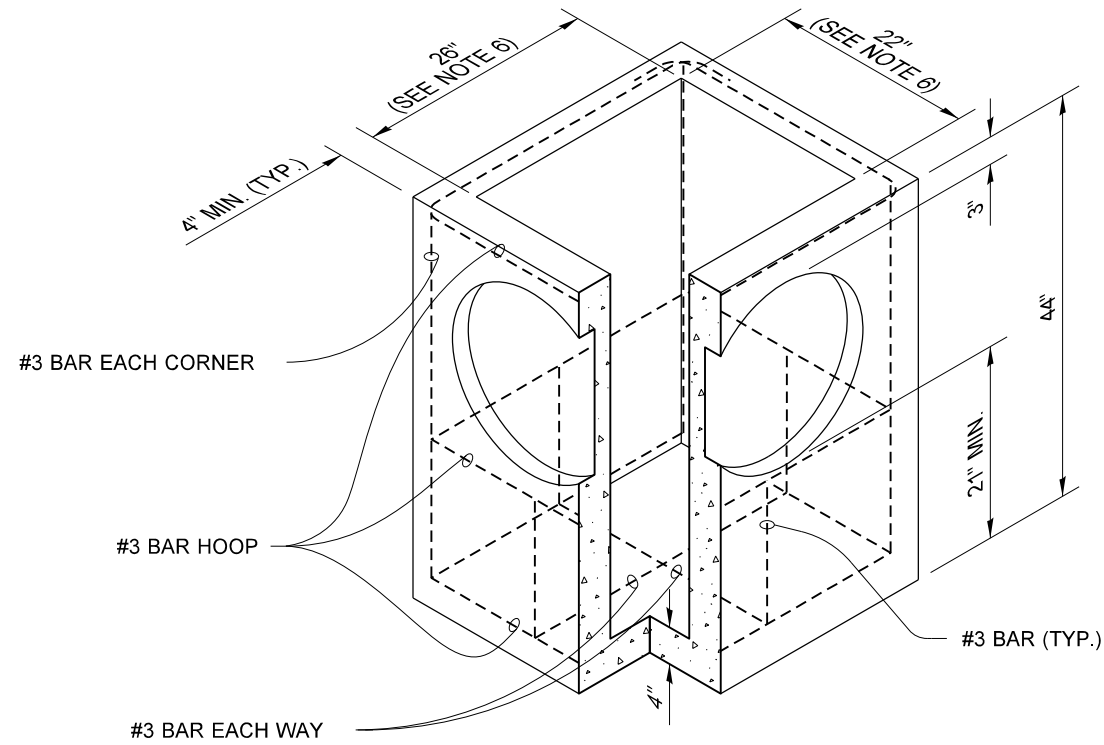

**PRECAST BASE SECTION**

PIPE ALLOWANCES	
PIPE MATERIAL	MAXIMUM INSIDE DIAMETER (INCHES)
REINFORCED OR PLAIN CONCRETE	12"
ALL METAL PIPE	15"
CPSSP * (STD. SPEC. SECT. 9-05.20)	12"
SOLID WALL PVC (STD. SPEC. SECT. 9-05.12(1))	15"
PROFILE WALL PVC (STD. SPEC. SECT. 9-05.12(2))	15"

\* CORRUGATED POLYETHYLENE STORM SEWER PIPE

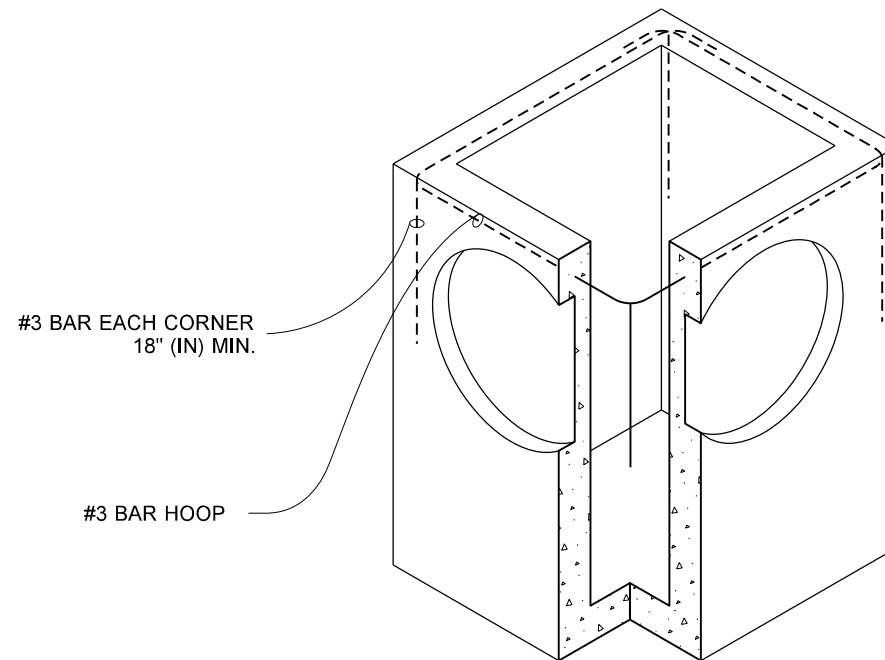

(SEE NOTE 1)

**ALTERNATIVE PRECAST BASE SECTION**

**NOTES**

1. As acceptable alternatives to the rebar shown in the **PRECAST BASE SECTION**, fibers (placed according to the Standard Specifications), or wire mesh having a minimum area of 0.12 square inches per foot shall be used with the minimum required rebar shown in the **ALTERNATIVE PRECAST BASE SECTION**. Wire mesh shall not be placed in the knockouts.
2. The knockout diameter shall not be greater than 20" (in). Knockouts shall have a wall thickness of 2" (in) minimum to 2.5" (in) maximum. Provide a 1.5" (in) minimum gap between the knockout wall and the outside of the pipe. After the pipe is installed, fill the gap with joint mortar in accordance with **Standard Specification Section 9-04.3**.
3. The maximum depth from the finished grade to the lowest pipe invert shall be 5' (ft).
4. The frame and grate may be installed with the flange down, or integrally cast into the adjustment section with flange up.
5. The Precast Base Section may have a rounded floor, and the walls may be sloped at a rate of 1 : 24 or steeper.
6. The opening shall be measured at the top of the **Precast Base Section**.
7. All pickup holes shall be grouted full after the basin has been placed.



Heilman, Julie  
Jan 25 2017 2:53 PM  
cosign

**CATCH BASIN TYPE 1**

**STANDARD PLAN B-5.20-02**

SHEET 1 OF 1 SHEET

APPROVED FOR PUBLICATION  
Carpenter, Jeff  
Jan 26 2017 6:48 AM  
cosign

STATE DESIGN ENGINEER



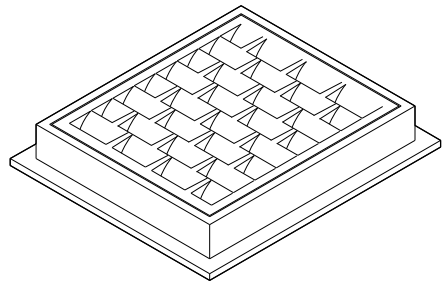

**FRAME AND VANED GRATE**

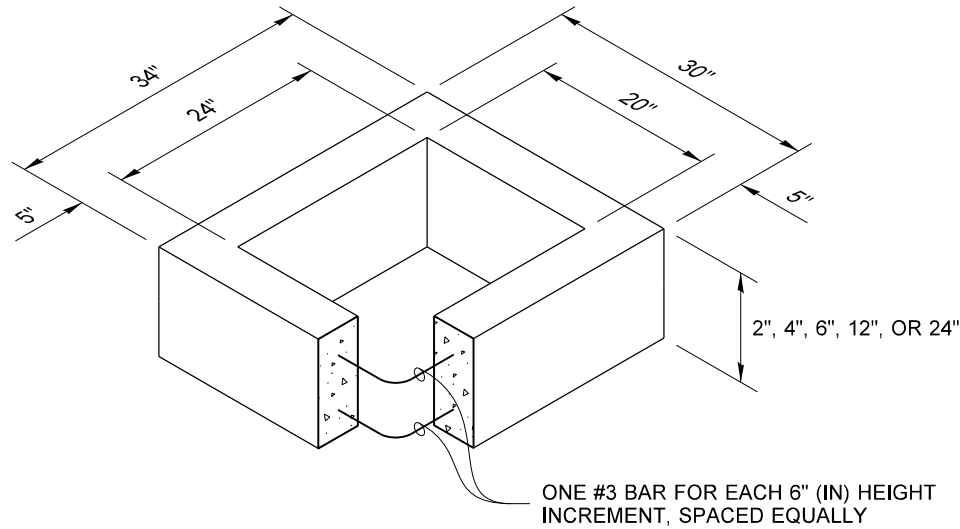

**RECTANGULAR ADJUSTMENT SECTION**

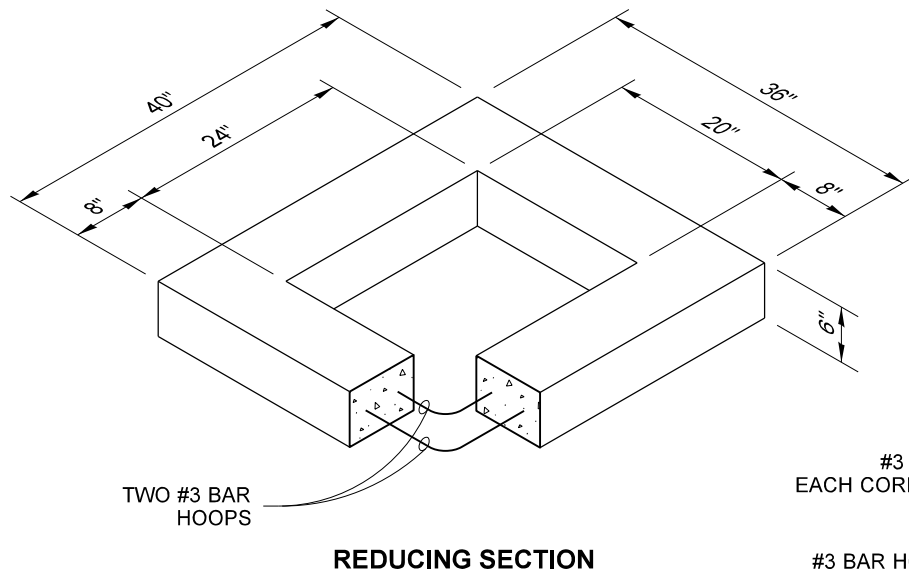

**REDUCING SECTION**

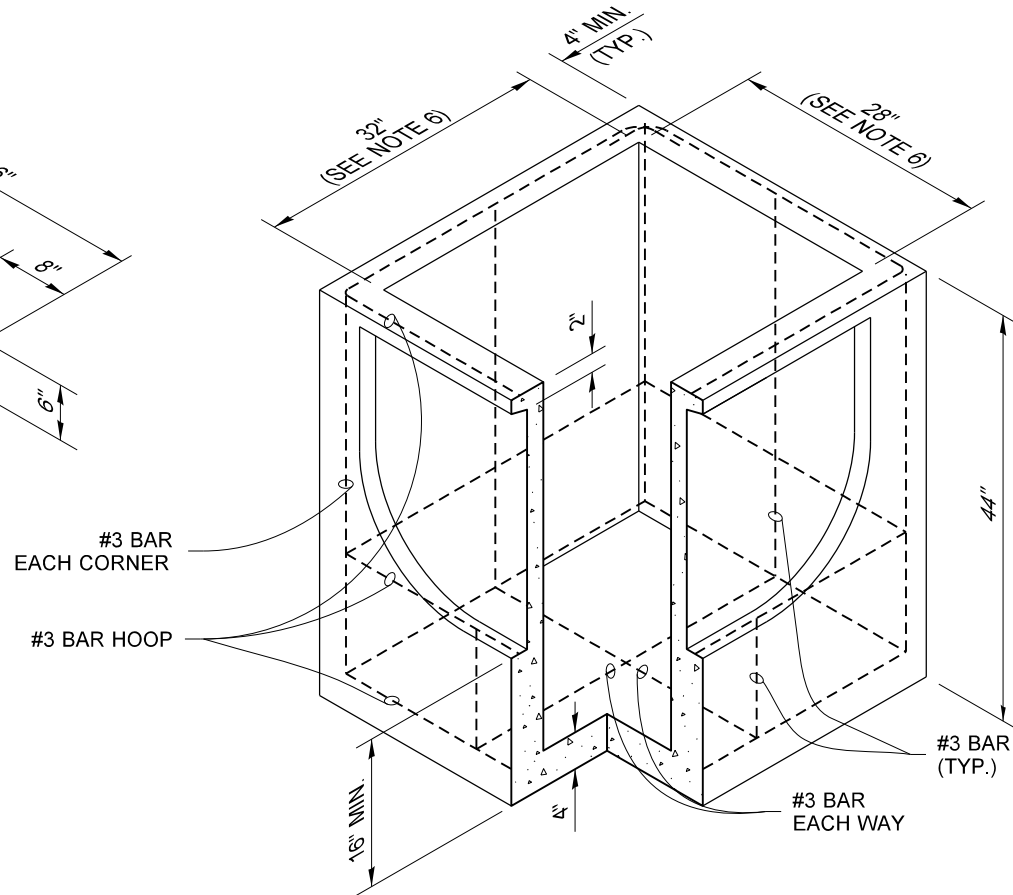

**PRECAST BASE SECTION**

PIPE ALLOWANCES	
PIPE MATERIAL	MAXIMUM INSIDE DIAMETER (INCHES)
REINFORCED OR PLAIN CONCRETE	18"
ALL METAL PIPE	21"
CPSSP * (STD. SPEC. SECT. 9-05.20)	18"
SOLID WALL PVC (STD. SPEC. SECT. 9-05.12(1))	21"
PROFILE WALL PVC (STD. SPEC. SECT. 9-05.12(2))	21"

\* CORRUGATED POLYETHYLENE STORM SEWER PIPE

**NOTES**

1. As acceptable alternatives to the rebar shown in the **PRECAST BASE SECTION**, fibers (placed according to the Standard Specifications), or wire mesh having a minimum area of 0.12 square inches per foot, shall be used with the minimum required rebar shown in the **ALTERNATIVE PRECAST BASE SECTION**. Wire mesh shall not be placed in the knockouts.
2. The knockout shall not be greater than 26" (in), in any direction. Knockouts shall have a wall thickness of 2" (in) minimum to 2.5" (in) maximum. Provide a 1.5" (in) minimum gap between the knockout wall and the outside of the pipe. After the pipe is installed, fill the gap with joint mortar in accordance with **Standard Specification Section 9-04.3**.
3. The maximum depth from the finished grade to the lowest pipe invert shall be 5' (ft).
4. The frame and grate may be installed with the flange down or integrally cast into the adjustment section with flange up.
5. The Precast Base Section may have a rounded floor, and the walls may be sloped at a rate of 1 : 24 or steeper.
6. The opening shall be measured at the top of the Precast Base Section.
7. All pickup holes shall be grouted full after the basin has been placed.

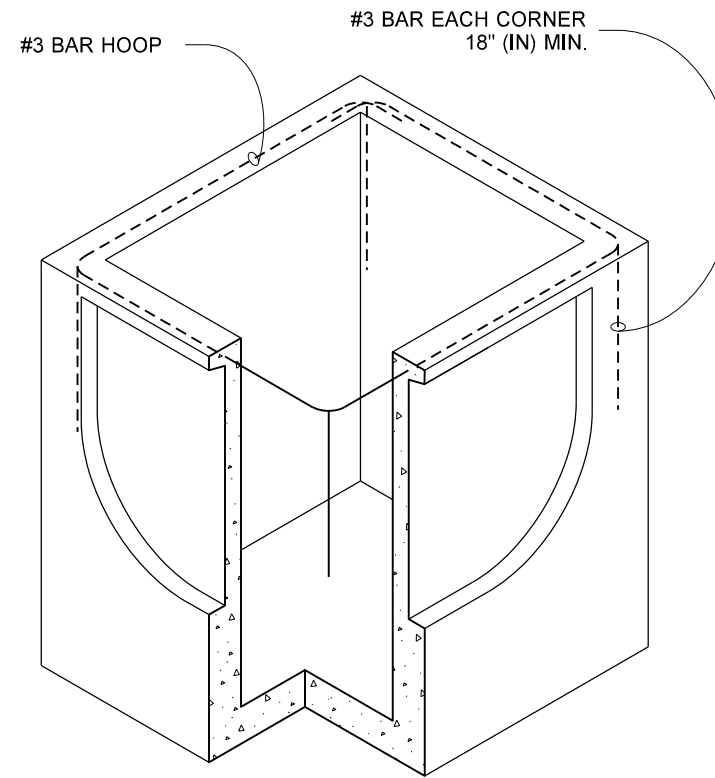

(SEE NOTE 1)  
**ALTERNATIVE PRECAST BASE SECTION**



Heilman, Julie  
Jan 25 2017 2:56 PM  
cosign

**CATCH BASIN TYPE 1L**

**STANDARD PLAN B-5.40-02**

SHEET 1 OF 1 SHEET

APPROVED FOR PUBLICATION

Carpenter, Jeff  
Jan 26 2017 6:49 AM  
cosign

STATE DESIGN ENGINEER



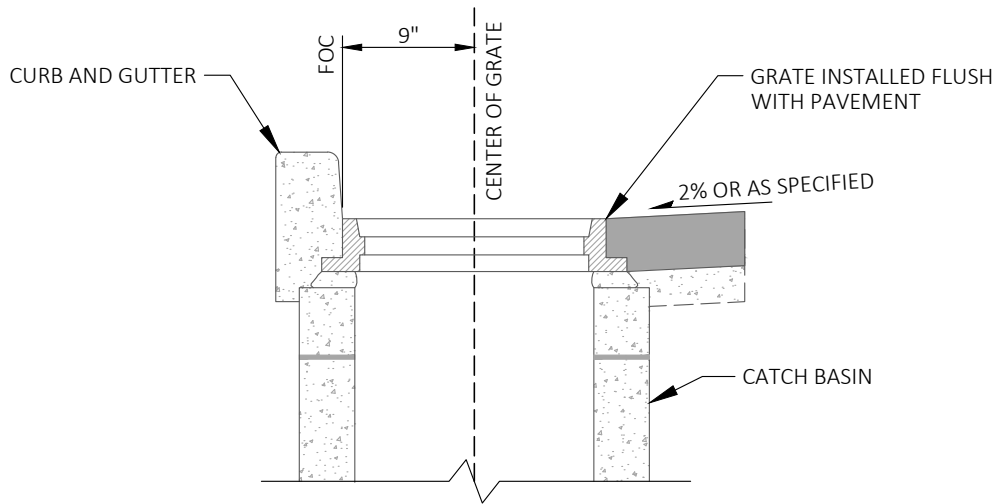

**SECTION A-A**

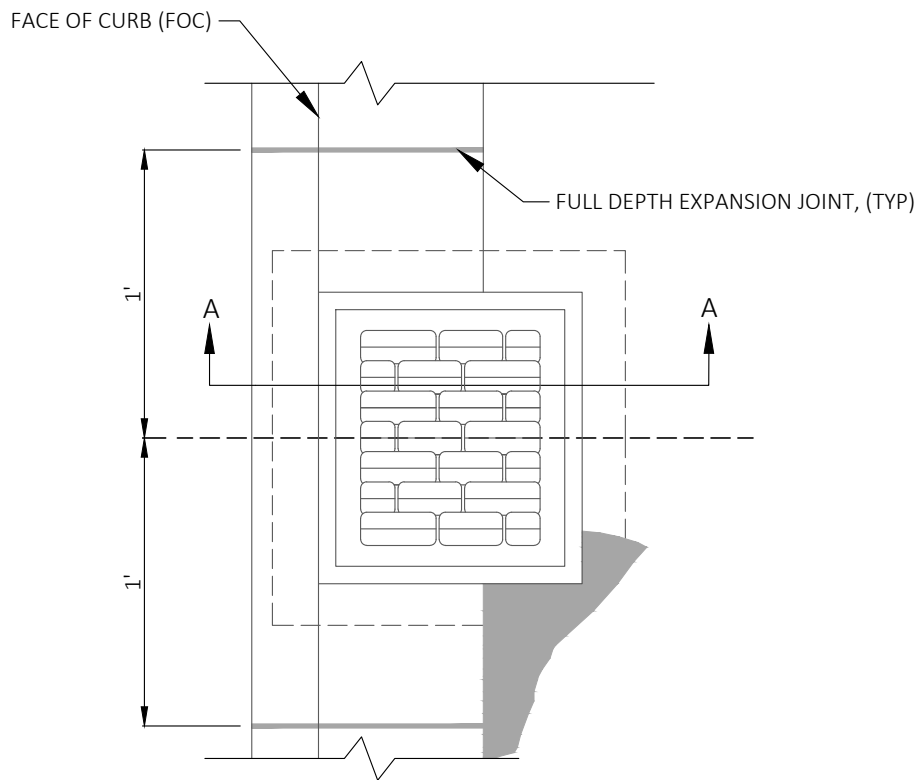

**PLAN VIEW**

**NOTES:**

1. AN APPROVED MATERIAL WHICH WILL PREVENT BONDING OF THE CURB TO FRAME, GRATE OR C.B. SHALL BE USED.
2. GROUT ALL JOINTS INSIDE AND OUTSIDE.
3. ALL GRATES SHALL BE VANED UNLESS OTHERWISE SHOWN.

*Tricia Juhnke*

APPROVED BY: TRICIA JUHNKE  
CITY ENGINEER



STANDARD DETAIL NUMBER: **707** SCALE: **NOT TO SCALE**

**CATCH BASIN INSTALLATION**

PUBLICATION DATE: 03/01/2020 | REVISION DATE: 02/11/2020

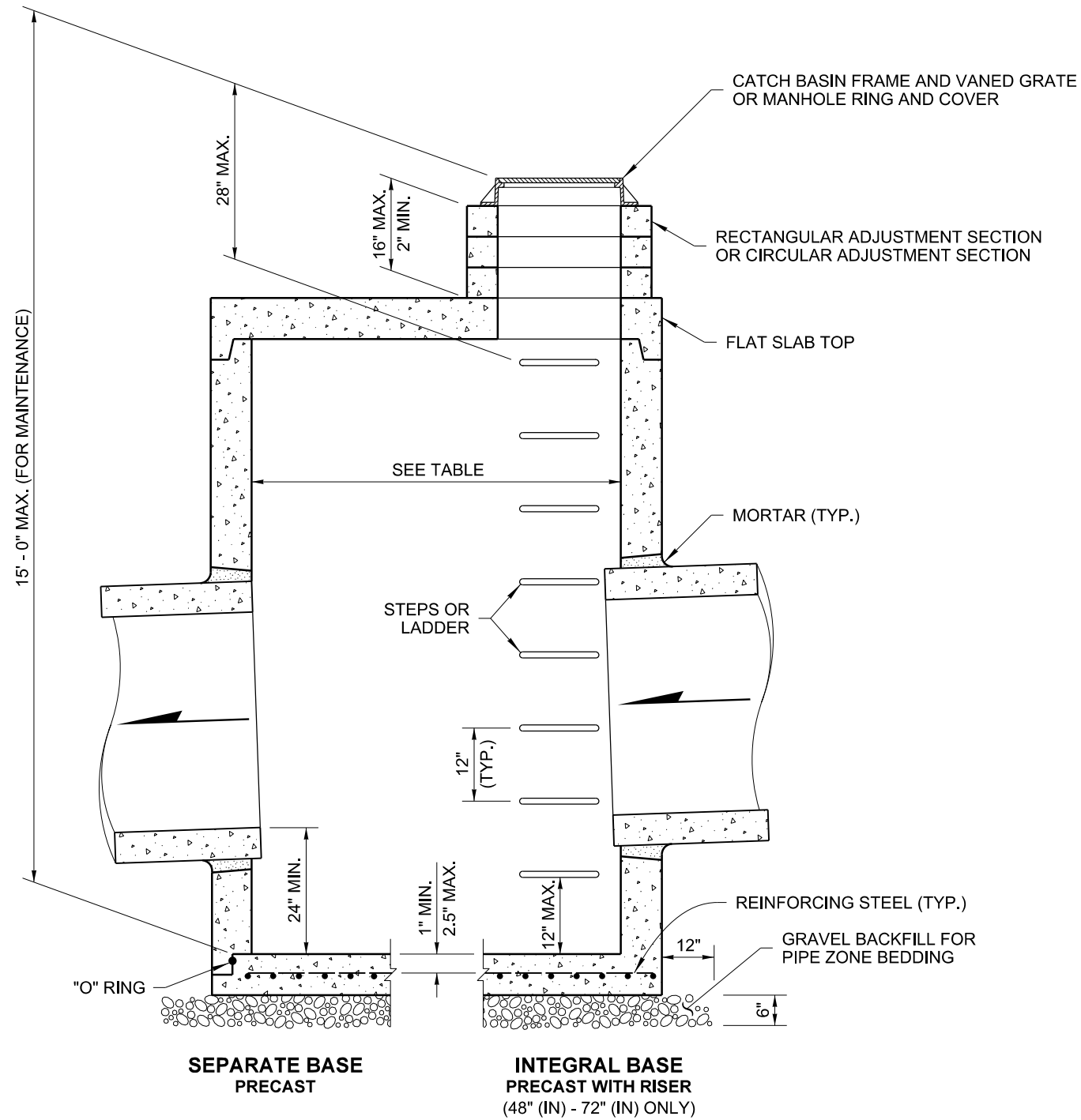

**NOTES**

1. No steps are required when height is 4' or less.
2. The bottom of the precast catch basin may be sloped to facilitate cleaning.
3. The rectangular frame and grate may be installed with the flange up or down. The frame may be cast into the adjustment section.
4. Knockouts shall have a wall thickness of 2" (in) minimum to 2.5" (in) maximum. Provide a 1.5" (in) minimum gap between the knockout wall and the outside of the pipe. After the pipe is installed, fill the gap with joint mortar in accordance with **Standard Specification Section 9-04.3**.

**CATCH BASIN DIMENSIONS**

CATCH BASIN DIAMETER	MIN. WALL THICKNESS	MIN. BASE THICKNESS	MAXIMUM KNOCKOUT SIZE	MINIMUM DISTANCE BETWEEN KNOCKOUTS
48"	4"	6"	36"	8"
54"	4.5"	8"	42"	8"
60"	5"	8"	48"	8"
72"	6"	8"	60"	12"
84"	8"	12"	72"	12"
96"	8"	12"	84"	12"
120"	10"	12"	96"	12"
144"	12"	12"	108"	12"

**PIPE ALLOWANCES**

CATCH BASIN DIAMETER	PIPE MATERIAL WITH MAXIMUM INSIDE DIAMETER				
	CONCRETE	ALL METAL	CPSSP ① PP ④	SOLID WALL PVC ②	PROFILE WALL PVC ③
48"	24"	30"	24"	30"	30"
54"	30"	36"	30"	36"	36"
60"	36"	42"	36"	42"	42"
72"	42"	54"	42"	48"	48"
84"	54"	60"	54"	48"	48"
96"	60"	72"	60"	48"	48"
120"	66"	84"	60"	48"	48"
144"	78"	96"	60"	48"	48"

- ① Corrugated Polyethylene Storm Sewer Pipe (See **Standard Specification Section 9-05.20**)
- ② (See **Standard Specification Section 9-05.12(1)**)
- ③ (See **Standard Specification Section 9-05.12(2)**)
- ④ Polypropylene Pipe (See **Standard Specification Section 9-05.24**)



Heilman, Julie  
Feb 20 2018 12:49 PM  
cosign

**CATCH BASIN TYPE 2**

**STANDARD PLAN B-10.20-02**

SHEET 1 OF 1 SHEET

APPROVED FOR PUBLICATION

Carpenter, Jeff  
Mar 2 2018 10:01 AM  
cosign

STATE DESIGN ENGINEER



DRAWN BY: FERN LIDDELL

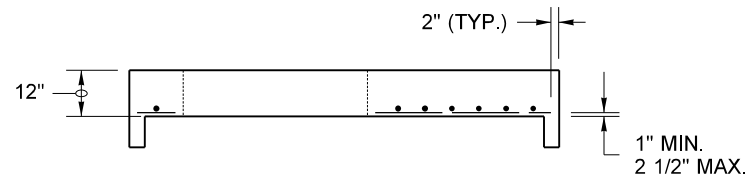
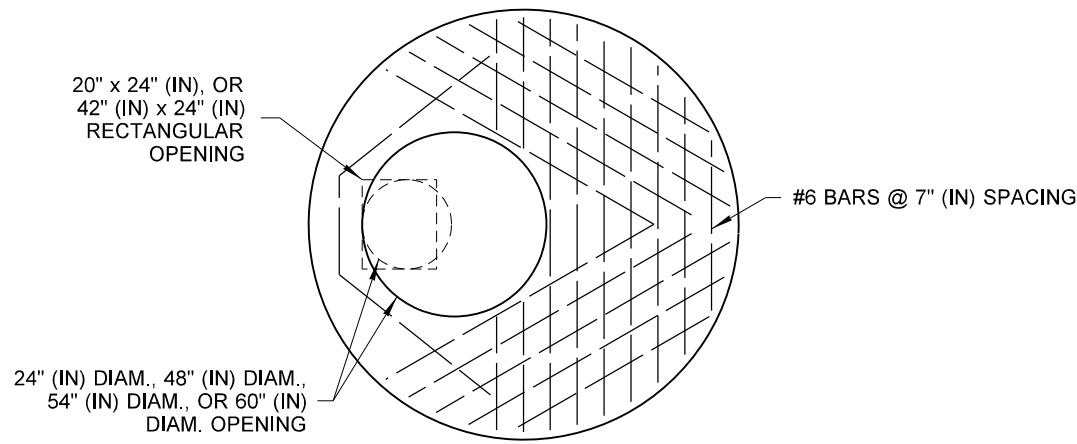

**84\" (IN) or 96\" (IN) FLAT SLAB TOP**

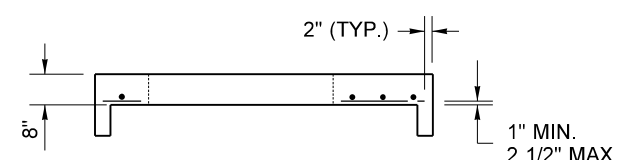
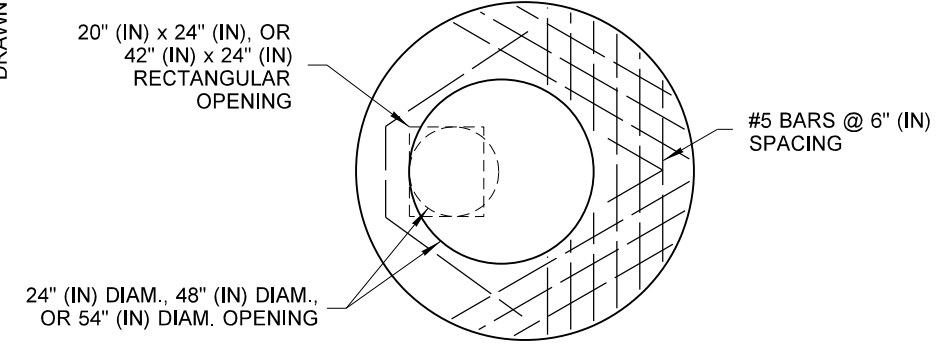

**72\" (IN) FLAT SLAB TOP**

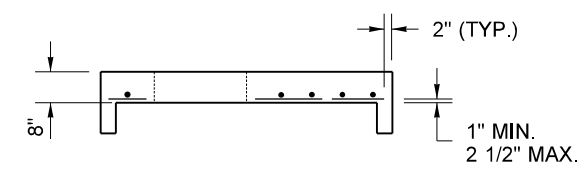
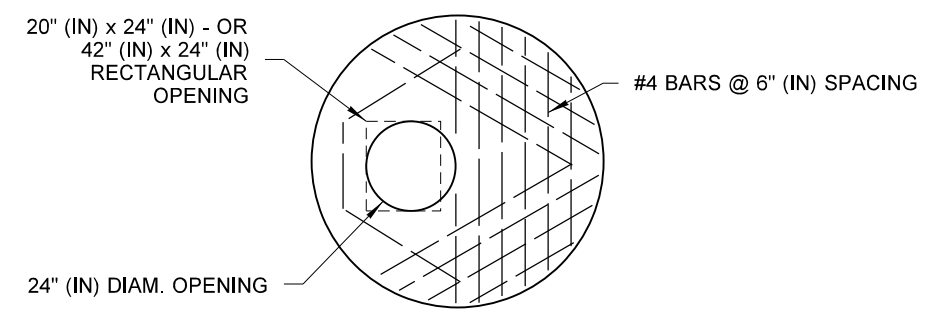

**48\" (IN), 54\" , or 60\" (IN) FLAT SLAB TOP**

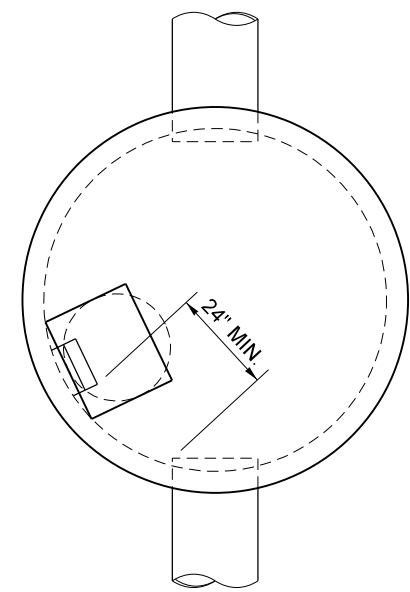

**TYPICAL ORIENTATION FOR ACCESS AND STEPS**

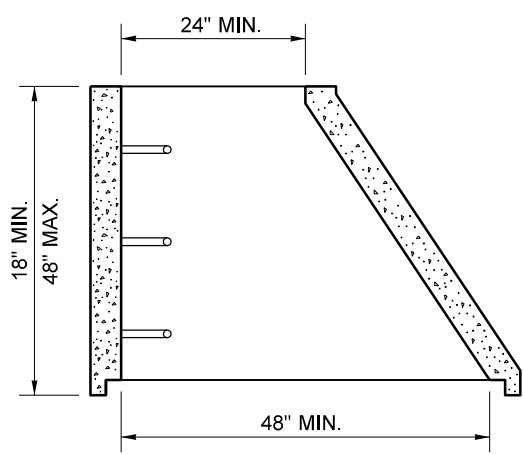

**ECCENTRIC CONE SECTION**

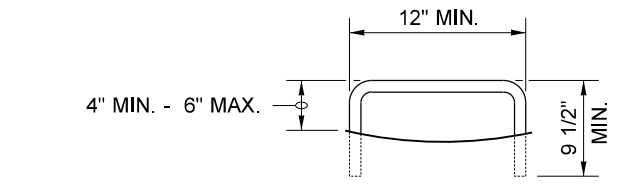

**STEP**

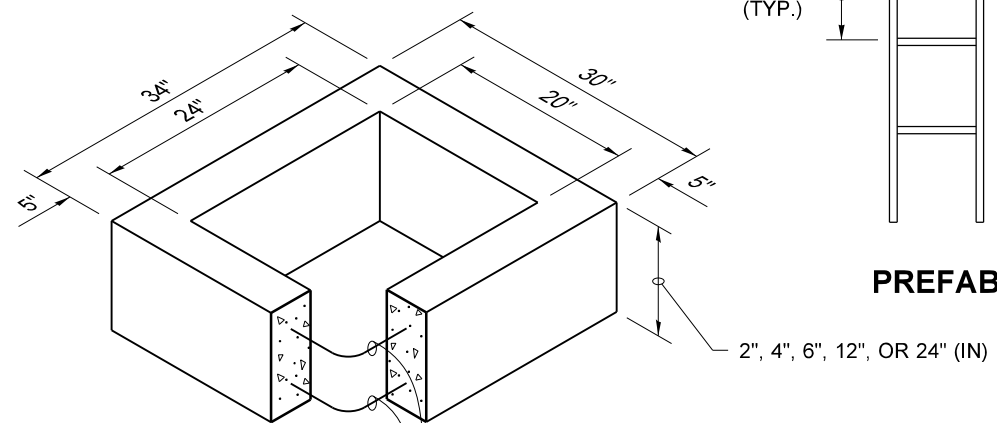

**PREFABRICATED LADDER**

**NOTE**  
1. Ladder rungs for manholes and catch basins shall meet the requirements of **AASHTO M 199**.

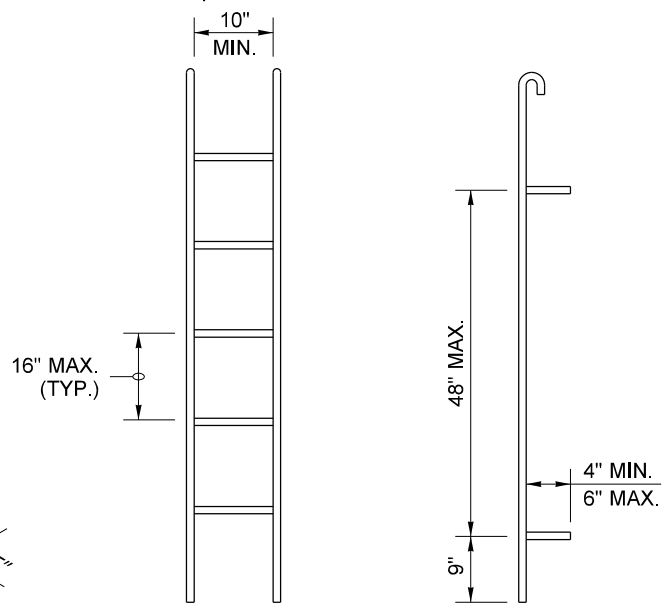

- ① ONE #3 BAR HOOP FOR 2", 4", OR 6" (IN)
- ② TWO #3 BAR HOOPS FOR 12" (IN)
- FOUR #3 BAR HOOPS FOR 24" (IN)

**RECTANGULAR ADJUSTMENT SECTION**

- ① As an acceptable alternative to rebar, wire mesh having a minimum area of 0.12 square inches per foot may be used for adjustment sections.
- ② As an acceptable alternative to conventional steel reinforcement, manufacturers shall use Synthetic Structural Fibers meeting the requirements of **Standard Specification Section 9-05.50(10)**.

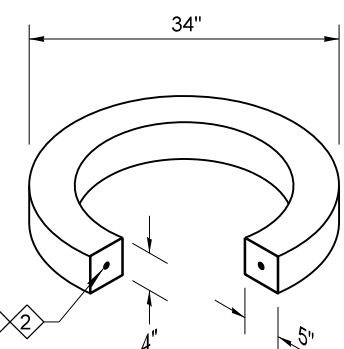

**CIRCULAR ADJUSTMENT SECTION**

For rectangular and circular adjustment sections, approved alternate material compositions are acceptable in lieu of precast concrete designs



Julie Heilman  
Heilman, Julie  
Jan 25 2017 3:01 PM

**MISCELLANEOUS DETAILS FOR DRAINAGE STRUCTURES STANDARD PLAN B-30.90-02**

SHEET 1 OF 1 SHEET

APPROVED FOR PUBLICATION  
Carpenter, Jeff  
Jan 26 2017 6:52 AM

STATE DESIGN ENGINEER  
Washington State Department of Transportation



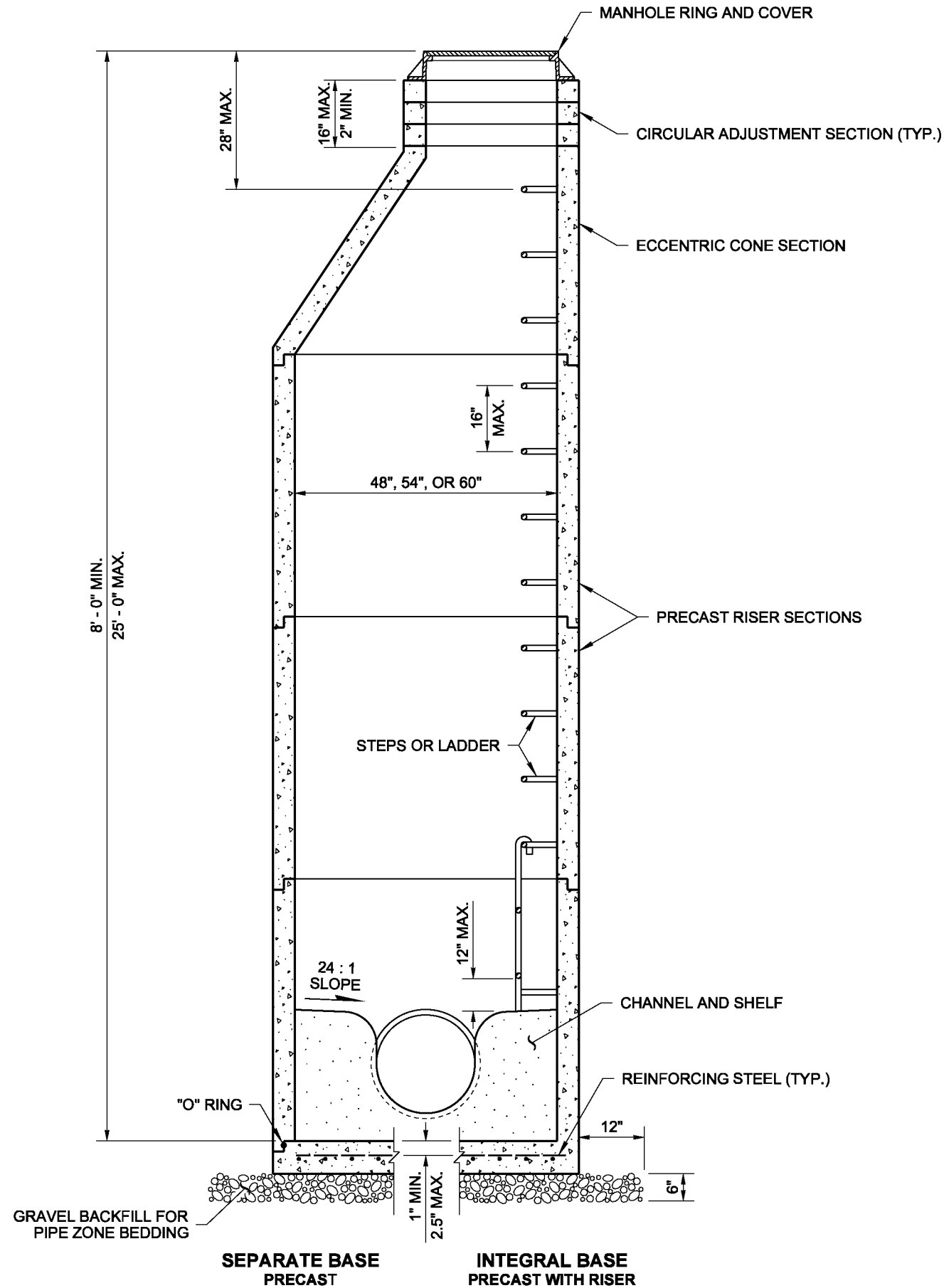

**NOTES**

1. Knockouts shall have a wall thickness of 2" minimum to 2.5" maximum.
2. For pipe allowances, see **Standard Plan B-10.20**.

MANHOLE DIMENSION TABLE				
DIAM.	MIN. WALL THICKNESS	MIN. BASE THICKNESS	MAXIMUM KNOCKOUT SIZE	MINIMUM DISTANCE BETWEEN KNOCKOUTS
48"	4"	6"	36"	8"
54"	4.5"	8"	42"	8"
60"	5"	8"	48"	8"



NOTE: THIS PLAN IS NOT A LEGAL ENGINEERING DOCUMENT UNTIL ELECTRONICALLY SIGNED BY THE ENGINEER AND APPROVED FOR PUBLICATION. IT MUST BE FILED AT THE WASHINGTON STATE DEPARTMENT OF TRANSPORTATION. A COPY MAY BE OBTAINED UPON REQUEST.

**MANHOLE TYPE 1**

**STANDARD PLAN B-15.20-01**

SHEET 1 OF 1 SHEET

APPROVED FOR PUBLICATION

**Pasco Bakotich III** 02-07-12

STATE DESIGN ENGINEER DATE

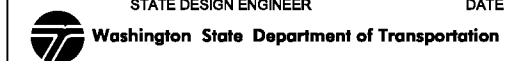

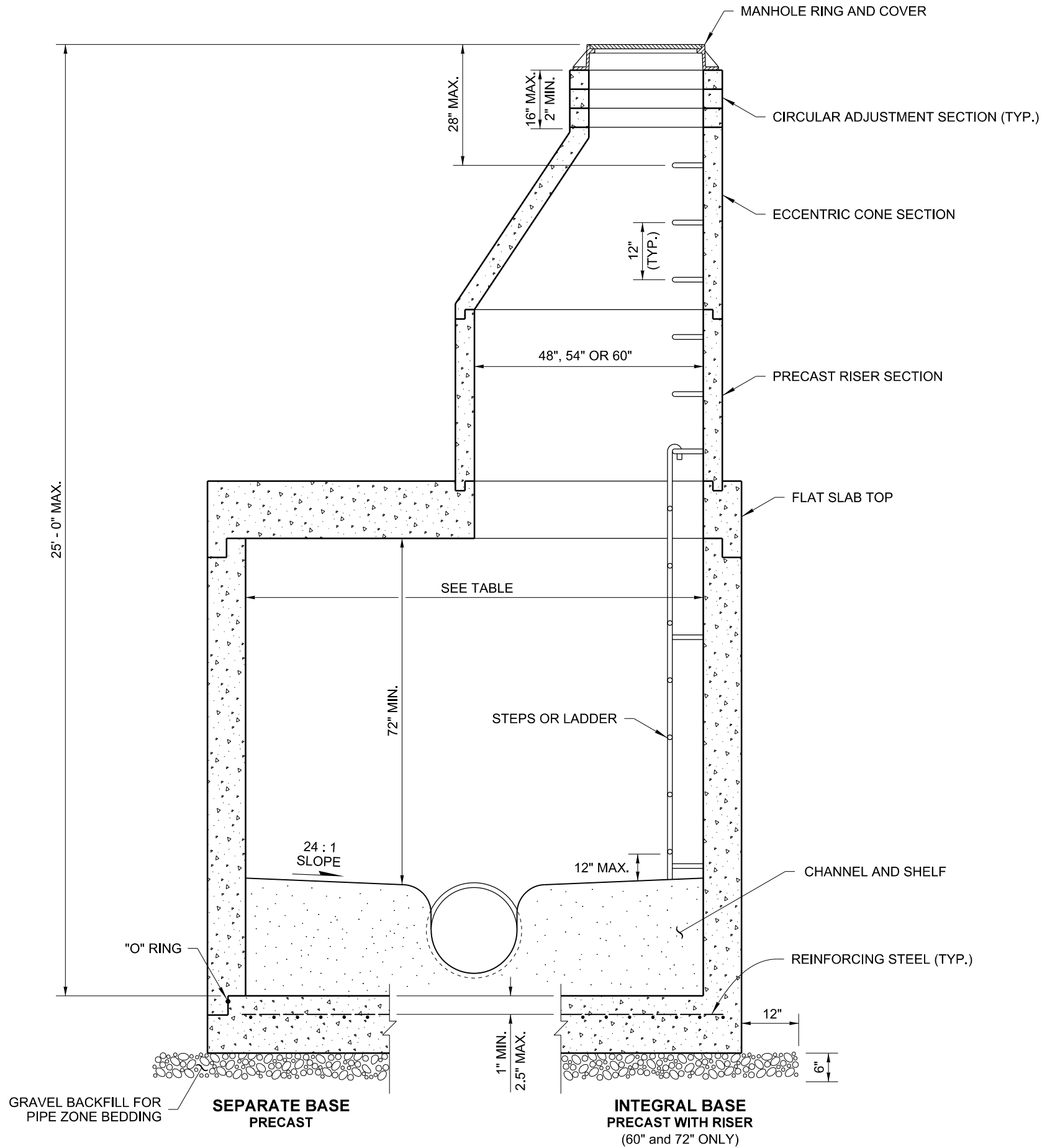

**NOTES**

1. Knockouts shall have a wall thickness of 2" minimum to 2.5" maximum.
2. For pipe allowances, see **Standard Plan B-10.20**.

MANHOLE DIMENSION TABLE				
DIAM.	MIN. WALL THICKNESS	MIN. BASE THICKNESS	MAXIMUM KNOCKOUT SIZE	MINIMUM DISTANCE BETWEEN KNOCKOUTS
60"	5"	8"	48"	8"
72"	6"	8"	60"	12"
84"	8"	12"	72"	12"
96"	8"	12"	84"	12"
120"	10"	12"	96"	12"
144"	12"	12"	108"	12"



NOTE: THIS PLAN IS NOT A LEGAL ENGINEERING DOCUMENT BUT AN ELECTRONIC DIGITAL COPY. THE ORIGINAL COPY OF THE ENGINEER AND APPROVED FOR PUBLICATION IS KEPT ON FILE AT THE WASHINGTON STATE DEPARTMENT OF TRANSPORTATION. A COPY MAY BE OBTAINED UPON REQUEST.

**MANHOLE TYPE 2**  
**STANDARD PLAN B-15.40-01**  
 SHEET 1 OF 1 SHEET

APPROVED FOR PUBLICATION

**Pasco Bakotich III** 02-07-12  
 STATE DESIGN ENGINEER DATE

Washington State Department of Transportation

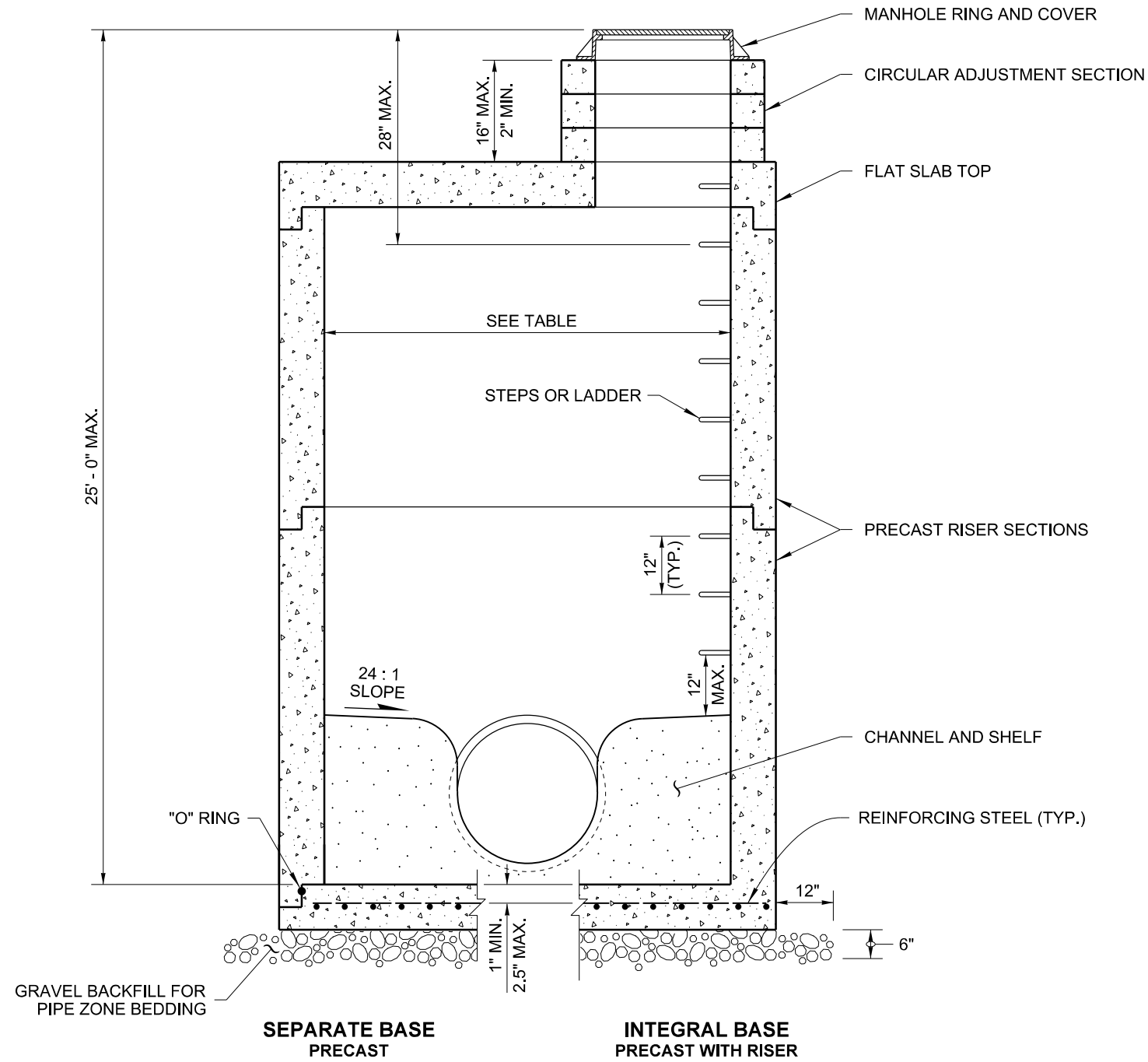

**NOTES**

1. Knockouts shall have a wall thickness of 2" (in) minimum to 2.5" (in) maximum.
2. For pipe allowances, see **Standard Plan B-10.20**.
3. No steps are required when height is 4' (ft) or less.

MANHOLE DIMENSION TABLE				
DIAM.	MIN. WALL THICKNESS	MIN. BASE THICKNESS	MAXIMUM KNOCKOUT SIZE	MINIMUM DISTANCE BETWEEN KNOCKOUTS
48"	4"	6"	36"	8"
54"	4.5"	8"	42"	8"
60"	5"	8"	48"	8"
72"	6"	8"	60"	12"
84"	8"	12"	72"	12"
96"	8"	12"	84"	12"
120"	10"	12"	96"	12"
144"	12"	12"	108"	12"



*Julie Heilman* Heilman, Julie  
Jan 25 2017 2:58 PM  
cosign

**MANHOLE TYPE 3**

**STANDARD PLAN B-15.60-02**

SHEET 1 OF 1 SHEET

APPROVED FOR PUBLICATION	
Carpenter, Jeff	
Jan 26 2017 6:50 AM	
STATE DESIGN ENGINEER	
Washington State Department of Transportation	

DRAWN BY: FERN LIDDELL

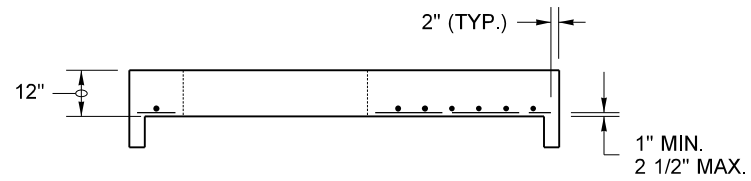
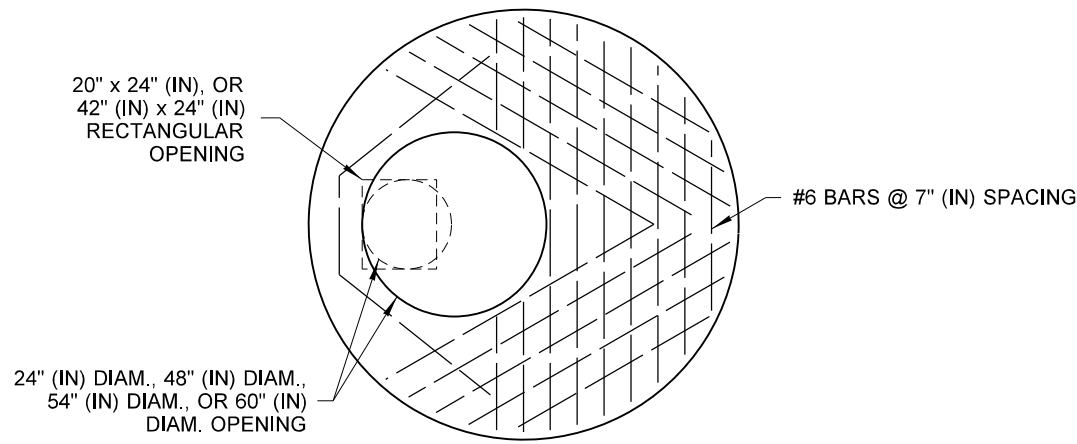

**84\" (IN) or 96\" (IN) FLAT SLAB TOP**

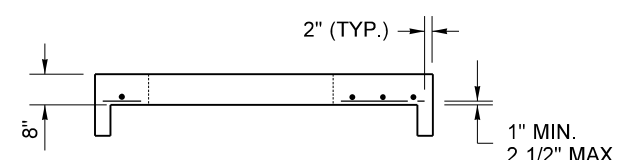
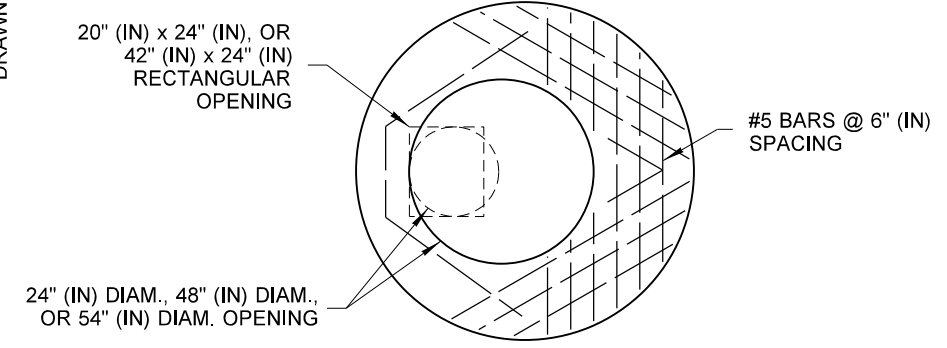

**72\" (IN) FLAT SLAB TOP**

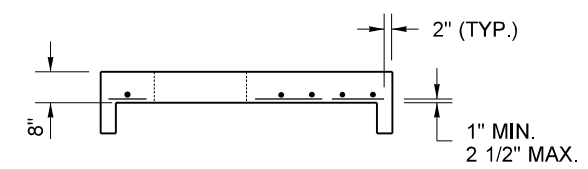
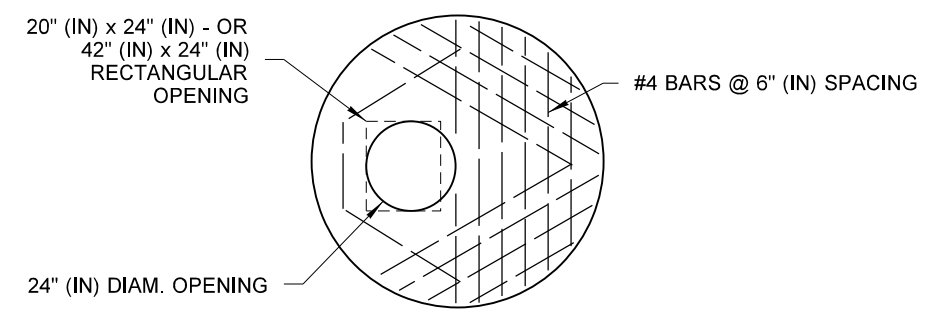

**48\" (IN), 54\" , or 60\" (IN) FLAT SLAB TOP**

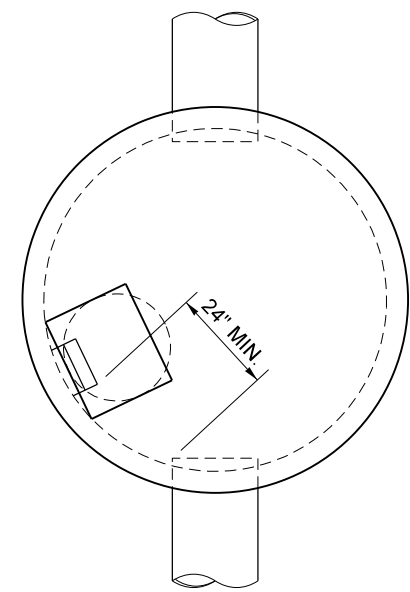

**TYPICAL ORIENTATION FOR ACCESS AND STEPS**

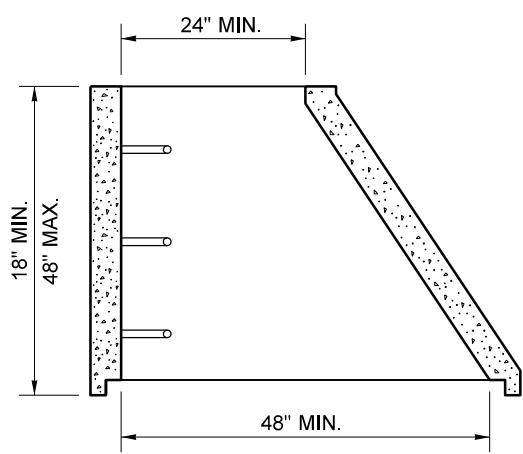

**ECCENTRIC CONE SECTION**

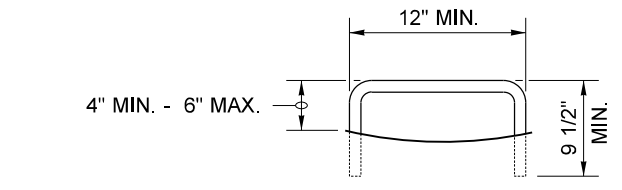

**STEP**

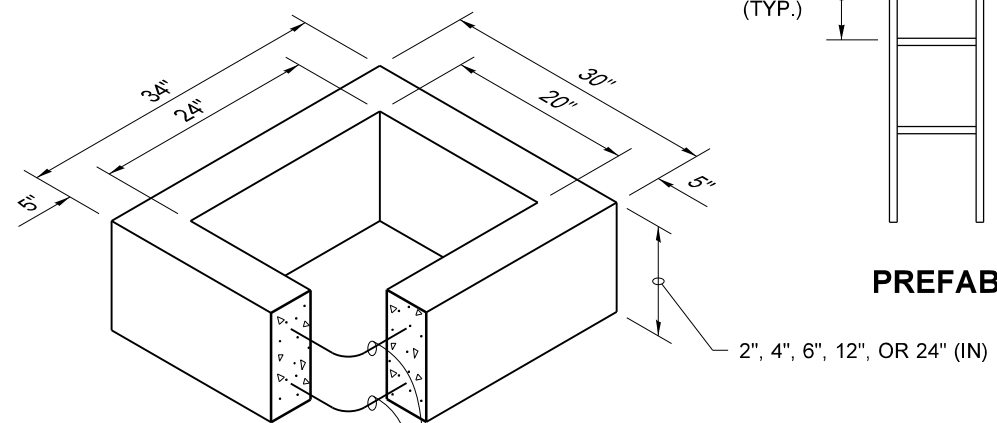

**PREFABRICATED LADDER**

**NOTE**  
1. Ladder rungs for manholes and catch basins shall meet the requirements of **AASHTO M 199**.

- 1 ONE #3 BAR HOOP FOR 2", 4", OR 6" (IN)
- 2 TWO #3 BAR HOOPS FOR 12" (IN)
- FOUR #3 BAR HOOPS FOR 24" (IN)

**RECTANGULAR ADJUSTMENT SECTION**

- 1 As an acceptable alternative to rebar, wire mesh having a minimum area of 0.12 square inches per foot may be used for adjustment sections.
- 2 As an acceptable alternative to conventional steel reinforcement, manufacturers shall use Synthetic Structural Fibers meeting the requirements of **Standard Specification Section 9-05.50(10)**.

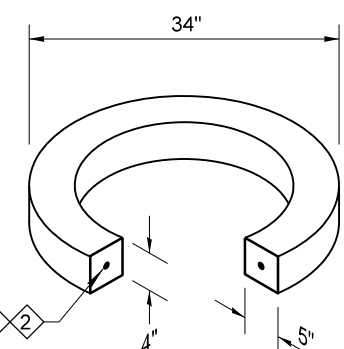

**CIRCULAR ADJUSTMENT SECTION**  
For rectangular and circular adjustment sections, approved alternate material compositions are acceptable in lieu of precast concrete designs



Heilman, Julie  
Jan 25 2017 3:01 PM  
**MISCELLANEOUS DETAILS FOR DRAINAGE STRUCTURES STANDARD PLAN B-30.90-02**

SHEET 1 OF 1 SHEET

APPROVED FOR PUBLICATION  
Carpenter, Jeff  
Jan 26 2017 6:52 AM

STATE DESIGN ENGINEER  
Washington State Department of Transportation

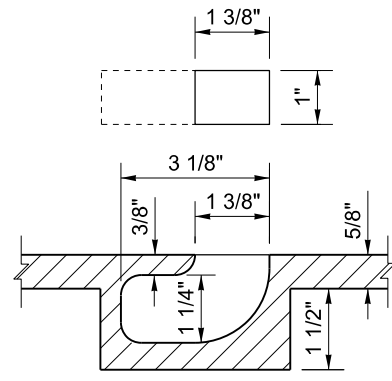

**BLIND PICK NOTCH  
DETAIL "A"**

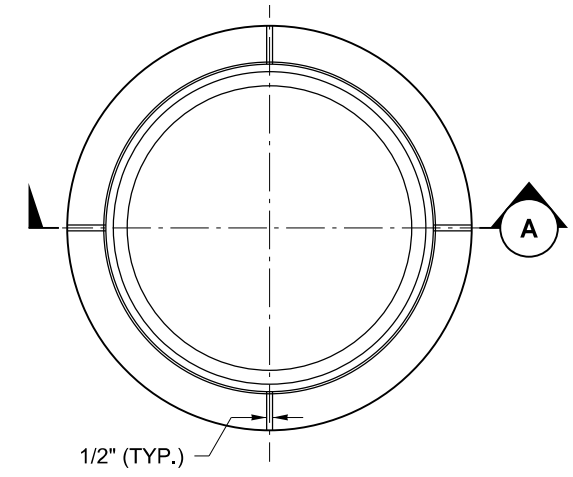

**RING PLAN**

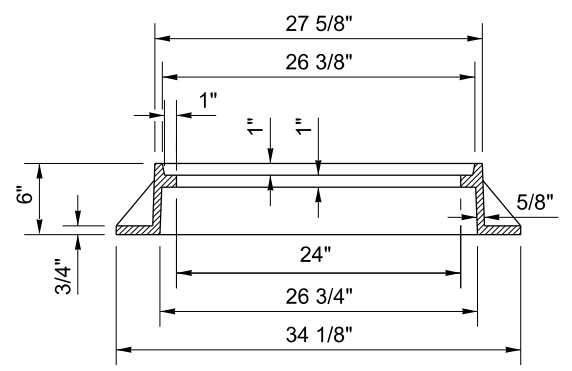

**RING SECTION A**

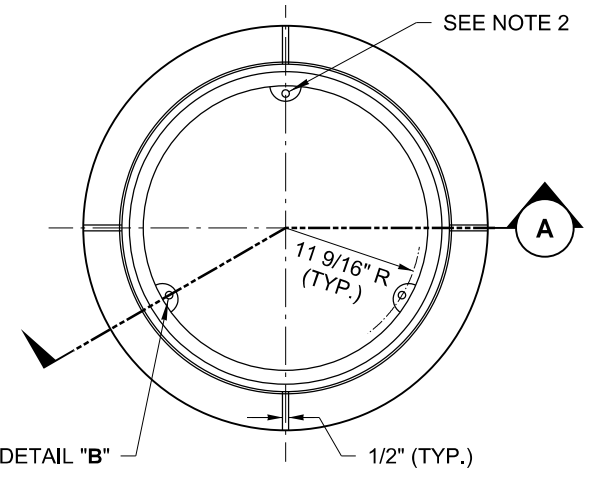

**RING PLAN**

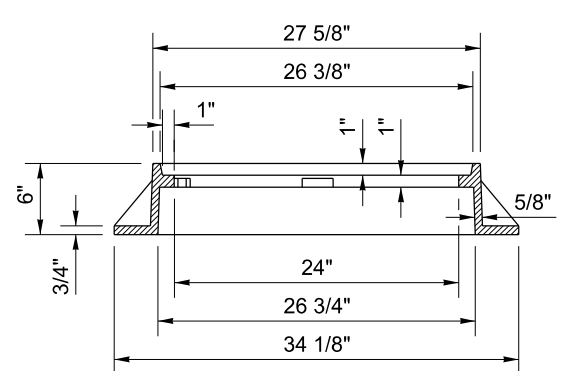

**RING SECTION A**

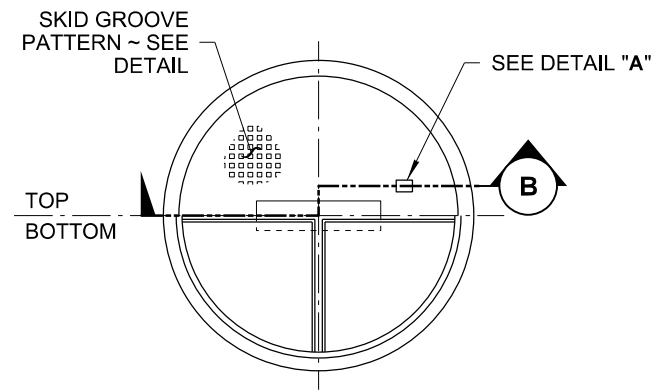

**COVER PLAN**

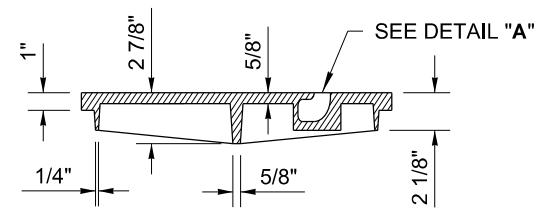

**COVER SECTION B  
(SEE NOTE 7)**

**STANDARD  
TYPE 1**

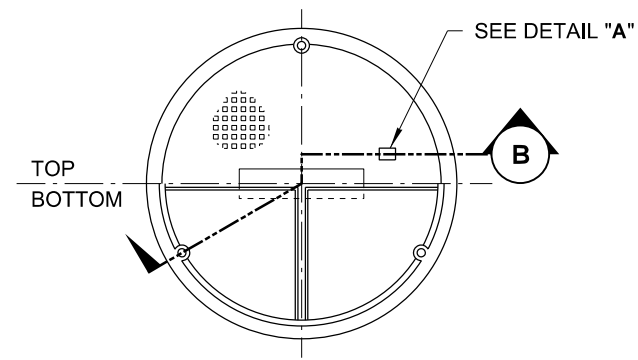

**COVER PLAN**

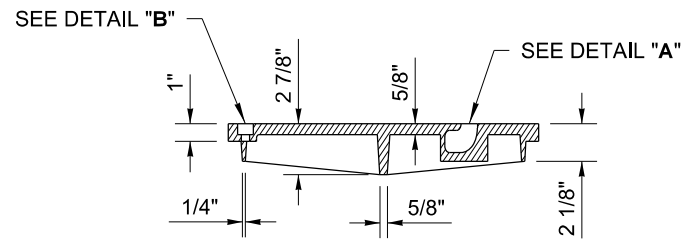

**COVER SECTION B  
(SEE NOTE 7)**

**BOLT-DOWN / WATERTIGHT  
TYPE 2**

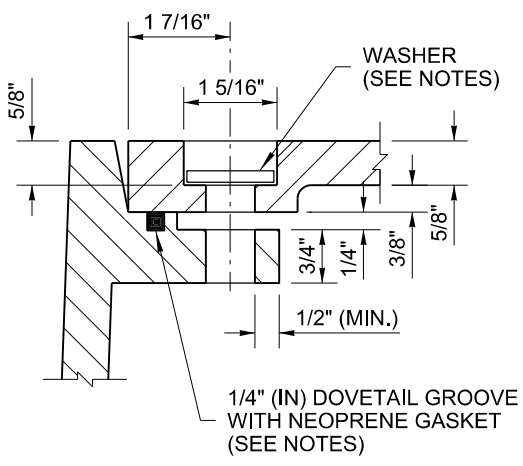

**BOLT-DOWN / WATERTIGHT  
DETAIL "B"**

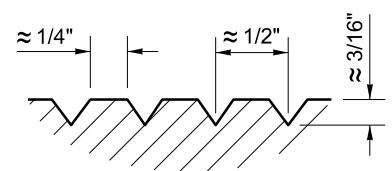

**SKID GROOVE PATTERN  
DETAIL**

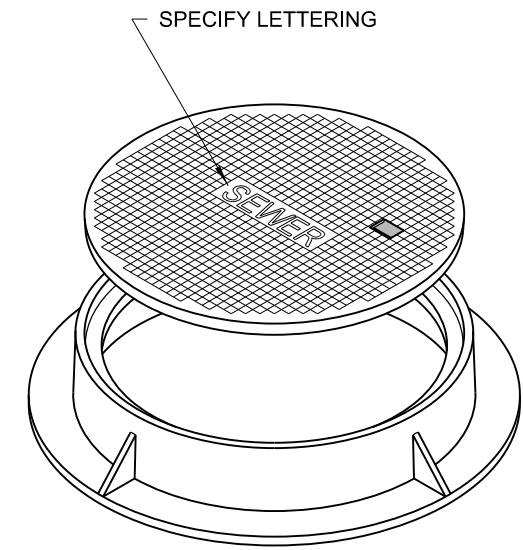

**ISOMETRIC VIEW**

**NOTES**

1. The gasket and groove may be in the seat (frame) or in the underside of the cover. The gasket may be "T" shaped in section. The groove may be cast or machined.
2. Bolt-down capability is required on all frames, grates, and covers, unless specified otherwise in the Contract. Provide 3 holes in the frame that are vertically aligned with the grate or cover slots. The frame shall accept the 304 Stainless Steel (S.S) 5/8" - 11 NC x 2" (in) allen head cap screw by being tapped, or other approved mechanism. Location of bolt down holes varies by manufacturer.
3. For bolt-down manhole ring and covers that are not designated "Watertight," the neoprene gasket, groove, and washer are not required.
4. Washer shall be neoprene (Detail "B").
5. In lieu of blind pick notch for manhole covers, a single 1" (in) pick hole is acceptable. Hole location and number of holes may vary by manufacturer.
6. Alternative reinforcing designs are acceptable in lieu of the rib design.
7. For clarity, the vertical scale of the Cover Section has been exaggerated, it is 1.5 times the horizontal scale (1H:1.5V).



Julie Heilman  
Heilman, Julie  
Feb 20 2018 12:55 PM  
cosign

**CIRCULAR FRAME (RING)  
AND COVER**

**STANDARD PLAN B-30.70-04**

SHEET 1 OF 1 SHEET

APPROVED FOR PUBLICATION  
Carpenter, Jeff  
Feb 27 2018 7:59 AM  
cosign

STATE DESIGN ENGINEER  
Washington State Department of Transportation

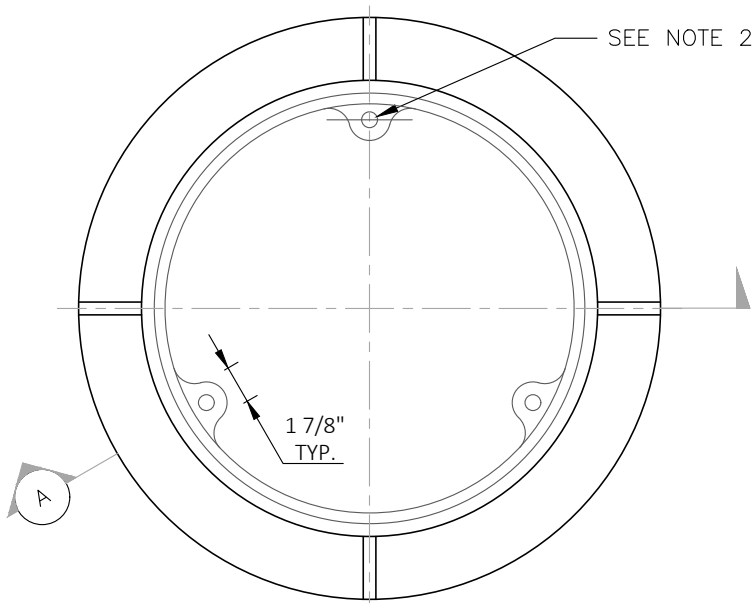

**PLAN**

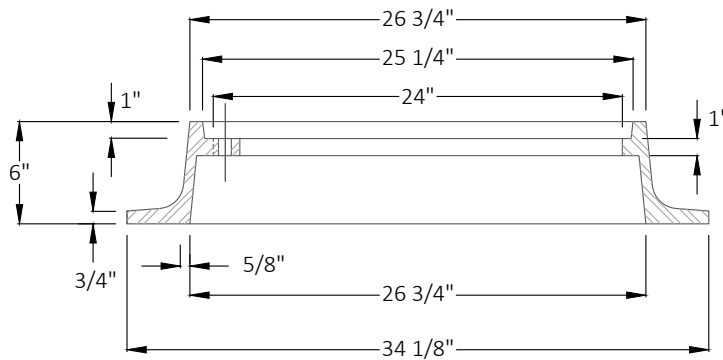

**SECTION A**

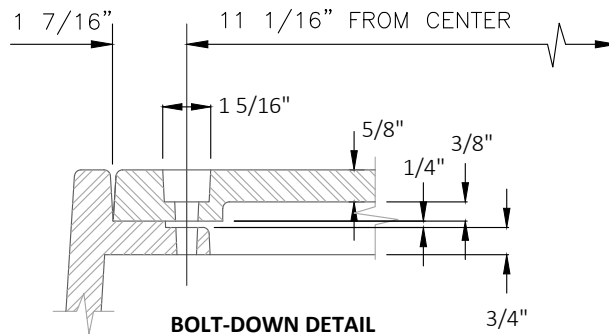

**BOLT-DOWN DETAIL**

**NOTES:**

1. MATERIAL IS CAST IRON ASTM A48 CLASS 30.
2. DRILL AND TAP THREE 5/8 IN-11 NC HOLES THROUGH FRAME AT 120° AND 11 1/16 IN RADIUS.
3. SEE WSDOT SPECIFICATION 7-05.
4. SEE THE WSDOT/APWA STANDARD SPECIFICATIONS SECTION 9-05.15 FOR METAL CASTINGS REQUIREMENTS.

*Tricia Juhnke*

APPROVED BY: TRICIA JUHNKE  
CITY ENGINEER



STANDARD DETAIL NUMBER: **721** SCALE: **NOT TO SCALE**

**LOCKING MANHOLE FRAME**

DRAWN BY: FERN LIDDELL

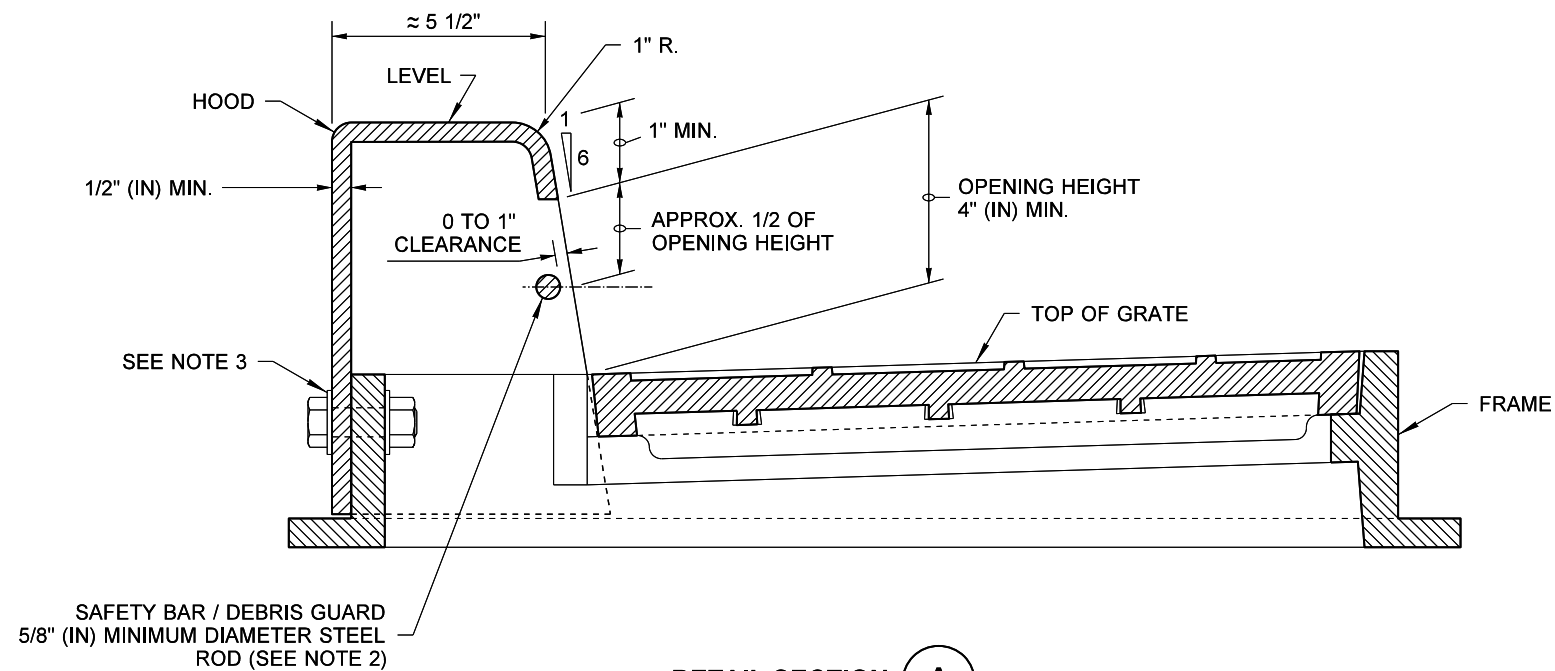

**DETAIL SECTION A**

**NOTES**

1. This inlet requires the precast catch basin unit to be rotated 90 degrees so that the narrow side is parallel to the curb line. When calculating offsets from curb to centerline (CL) of the precast catch basin, please note that the CL of the grate is not the CL of the precast catch basin. See **Section A**.
2. The dimensions of the frame and hood may vary slightly among different manufacturers. The Frame may have cast features intended to support a debris guard. Hood units may be mounted inside or outside of the frame. The methods for fastening the safety bar / debris guard rod to the hood may vary. The hood may include casting lugs. The top of the hood may be cast with a pattern.
3. Attach the hood to the frame with two 3/4" (in) x 2" (in) hex head bolts, nuts, and oversize washers. The washers shall have diameters adequate to ensure full bearing across the slots.
4. Bolt-down capability is required on all frames, grates and covers, unless specified otherwise in the Contract. Provide two holes in the frame that are vertically aligned with the grate or cover slots. The frame shall accept the 304 Stainless Steel (S.S.) 5/8" (in) - 11 NC x 2" (in) allen head cap screw by being tapped, or other approved mechanism. Location of bolt-down holes varies by manufacturer. See **BOLT-DOWN DETAIL, Standard Plan B-30.10**.
5. Only ductile iron Vaned Grates shall be used. See **Standard Plans B-30.30 and B-30.40** for grate details. Refer to **Standard Specification Section 9-05.15(2)** for additional requirements.
6. This plan is intended to show the installation details of a manufactured product. This plan is not intended to show the specific details necessary to fabricate the castings depicted in this drawing.

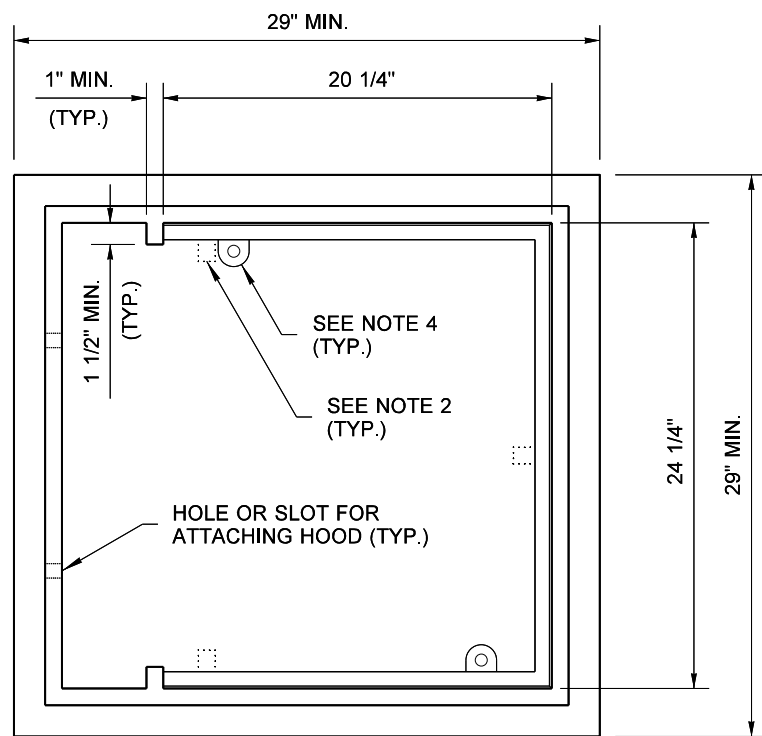

**TOP VIEW  
FRAME DETAIL**

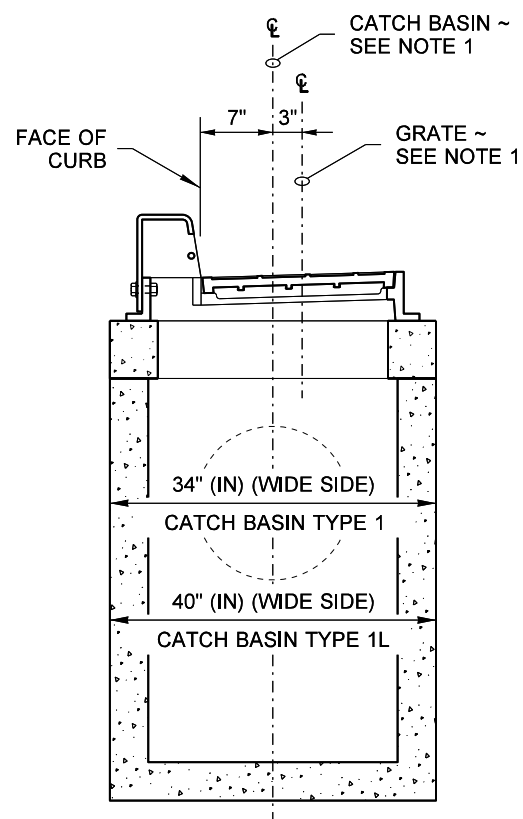

**SECTION A**

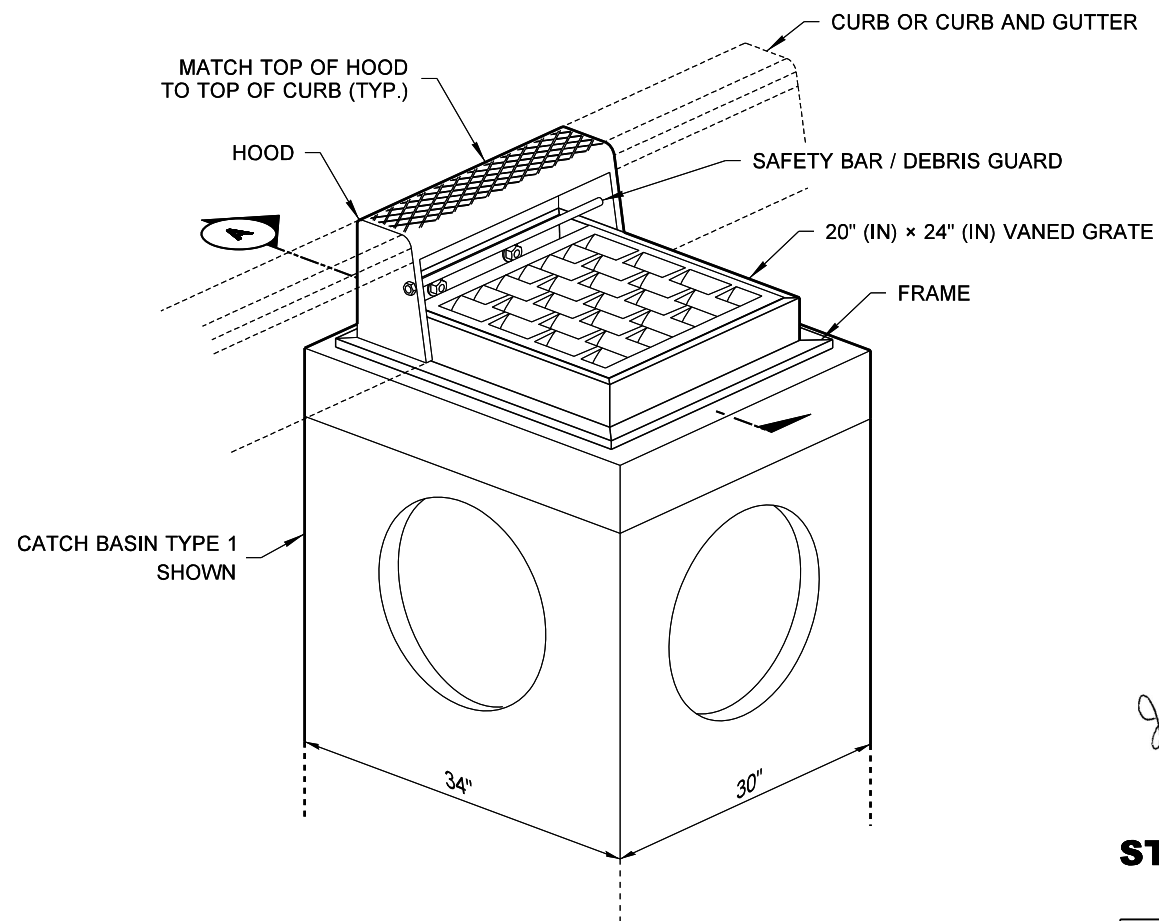

**ISOMETRIC VIEW  
COMBINATION INLET  
FRAME, HOOD, AND VANED GRATE**



Heilman, Julie  
Feb 20 2018 12:51 PM  
cosign

**COMBINATION INLET**

**STANDARD PLAN B-25.20-02**

SHEET 1 OF 1 SHEET

APPROVED FOR PUBLICATION

*Jeff Carpenter*  
Carpenter, Jeff  
Feb 27 2018 7:43 AM  
cosign

STATE DESIGN ENGINEER

Washington State Department of Transportation

DRAWN BY: FERN LIDDELL

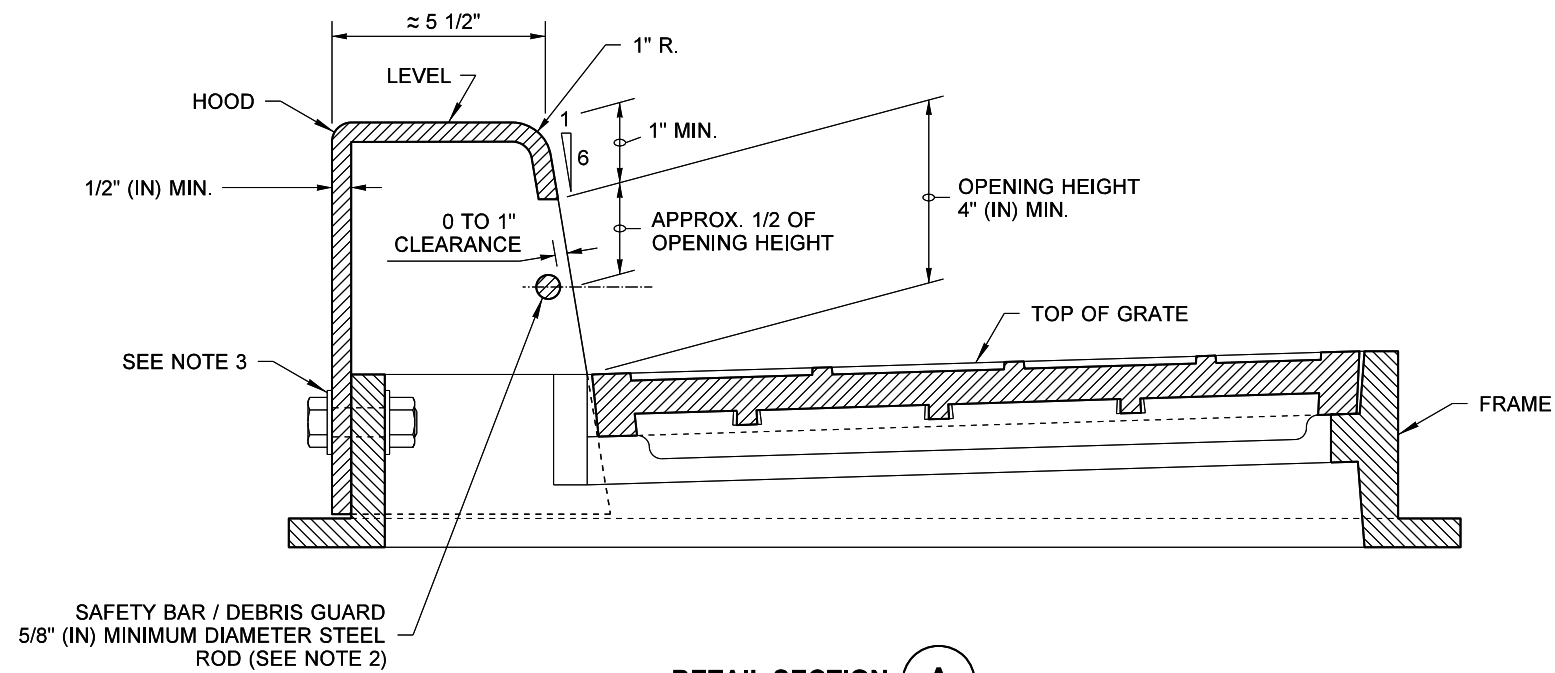

**DETAIL SECTION A**

**NOTES**

1. This inlet requires the precast catch basin unit to be rotated 90 degrees so that the narrow side is parallel to the curb line. When calculating offsets from curb to centerline (CL) of the precast catch basin, please note that the CL of the grate is not the CL of the precast catch basin. See **Section A**.
2. The dimensions of the frame and hood may vary slightly among different manufacturers. The Frame may have cast features intended to support a debris guard. Hood units may be mounted inside or outside of the frame. The methods for fastening the safety bar / debris guard rod to the hood may vary. The hood may include casting lugs. The top of the hood may be cast with a pattern.
3. Attach the hood to the frame with two 3/4" (in) x 2" (in) hex head bolts, nuts, and oversize washers. The washers shall have diameters adequate to ensure full bearing across the slots.
4. Bolt-down capability is required on all frames, grates and covers, unless specified otherwise in the Contract. Provide two holes in the frame that are vertically aligned with the grate or cover slots. The frame shall accept the 304 Stainless Steel (S.S.) 5/8" (in) - 11 NC x 2" (in) allen head cap screw by being tapped, or other approved mechanism. Location of bolt-down holes varies by manufacturer. See **BOLT-DOWN DETAIL, Standard Plan B-30.10**.
5. Only ductile iron Vaned Grates shall be used. See **Standard Plans B-30.30 and B-30.40** for grate details. Refer to **Standard Specification Section 9-05.15(2)** for additional requirements.
6. This plan is intended to show the installation details of a manufactured product. This plan is not intended to show the specific details necessary to fabricate the castings depicted in this drawing.

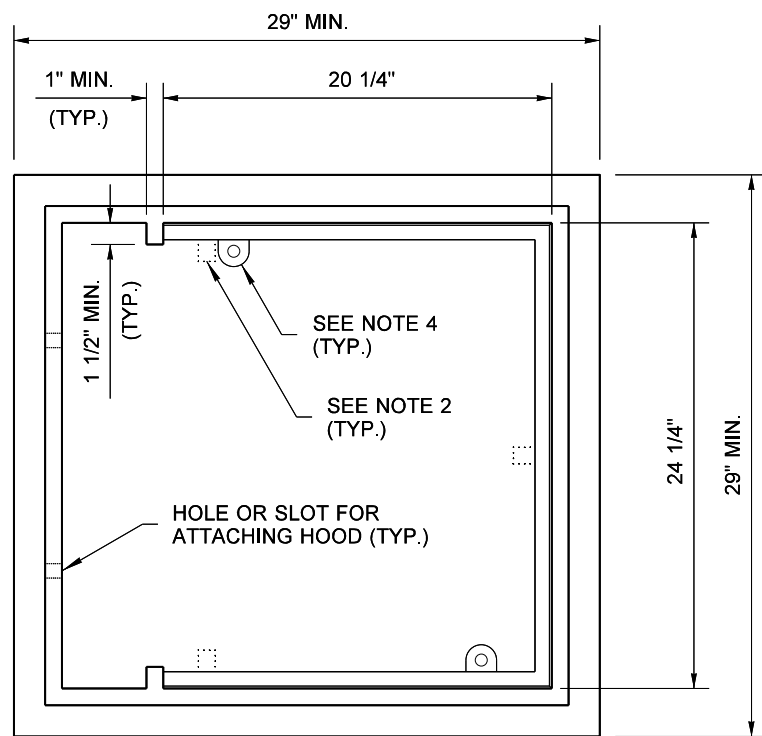

**TOP VIEW  
FRAME DETAIL**

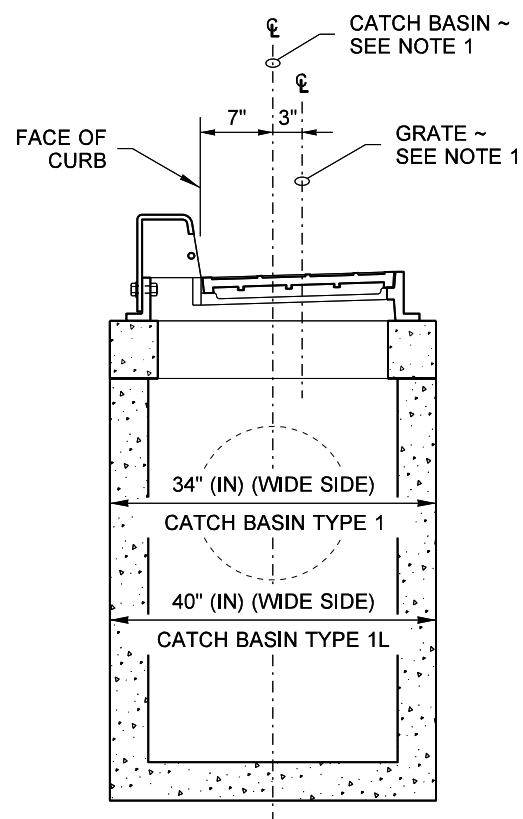

**SECTION A**

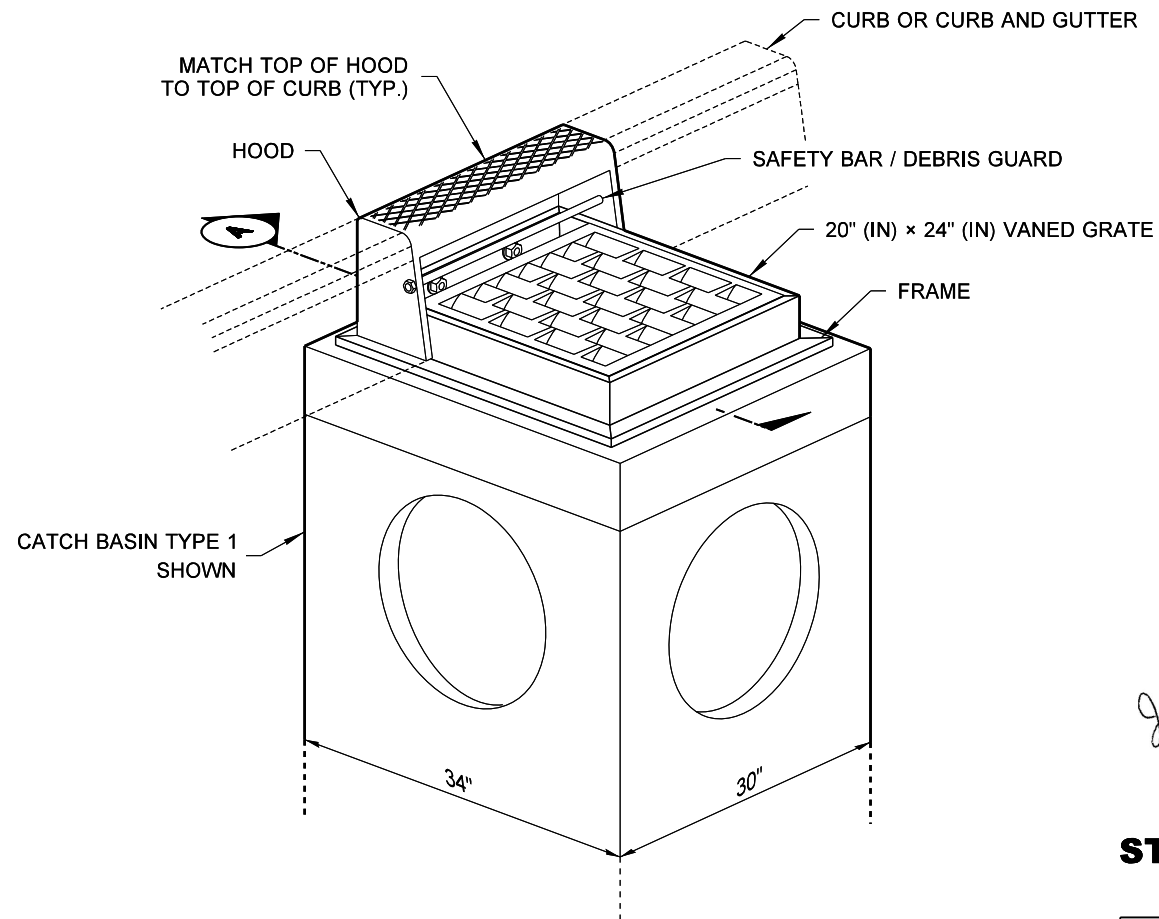

**ISOMETRIC VIEW  
COMBINATION INLET  
FRAME, HOOD, AND VANED GRATE**



*Julie Heilman*  
Heilman, Julie  
Feb 20 2018 12:51 PM  
cosign

**COMBINATION INLET**

**STANDARD PLAN B-25.20-02**

SHEET 1 OF 1 SHEET

APPROVED FOR PUBLICATION

*Jeff Carpenter*  
Carpenter, Jeff  
Feb 27 2018 7:43 AM  
cosign

STATE DESIGN ENGINEER





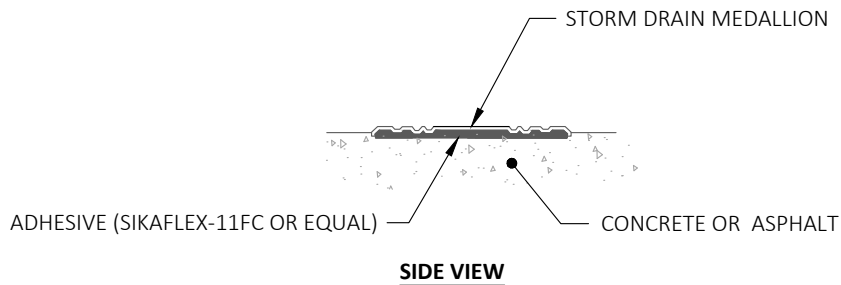
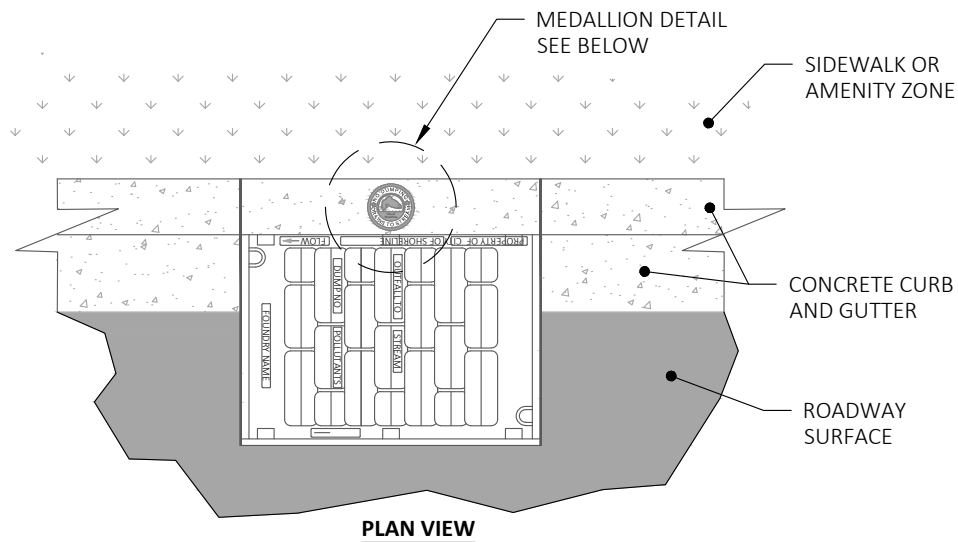

**TOP VIEW**

**NOTE:**

1. CLEAN MOUNTING SURFACE USING WIRE BRUSH. BLOW ALL DUST AND DEBRIS FROM MOUNTING AREA.
2. APPLY ADHESIVE TO BACK OF MEDALLION.
3. PLACE MEDALLION ON TOP SURFACE OF CURB OR AS DIRECTED BY ENGINEER.
4. ENSURE MEDALLION IS SEATED INTO ADHESIVE BY APPLYING PRESSURE AS REQUIRED.

*Tricia Juhnke*

APPROVED BY: TRICIA JUHNKE  
CITY ENGINEER



STANDARD DETAIL NUMBER: **725** SCALE: **NOT TO SCALE**

**STORM DRAIN MEDALLION**

DRAWN BY: FERN LIDDELL

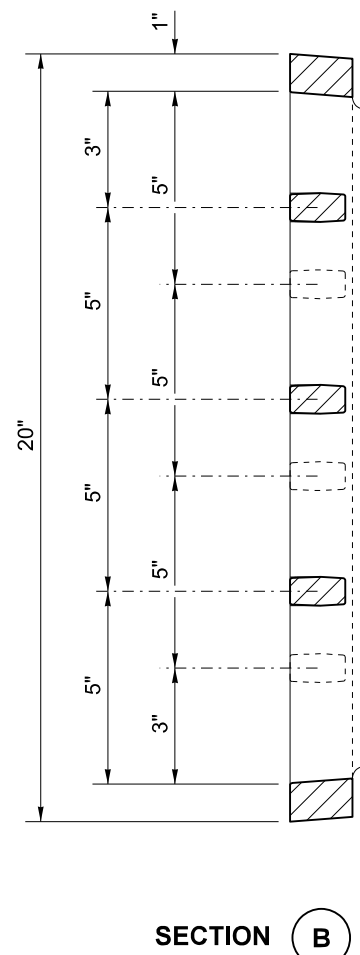
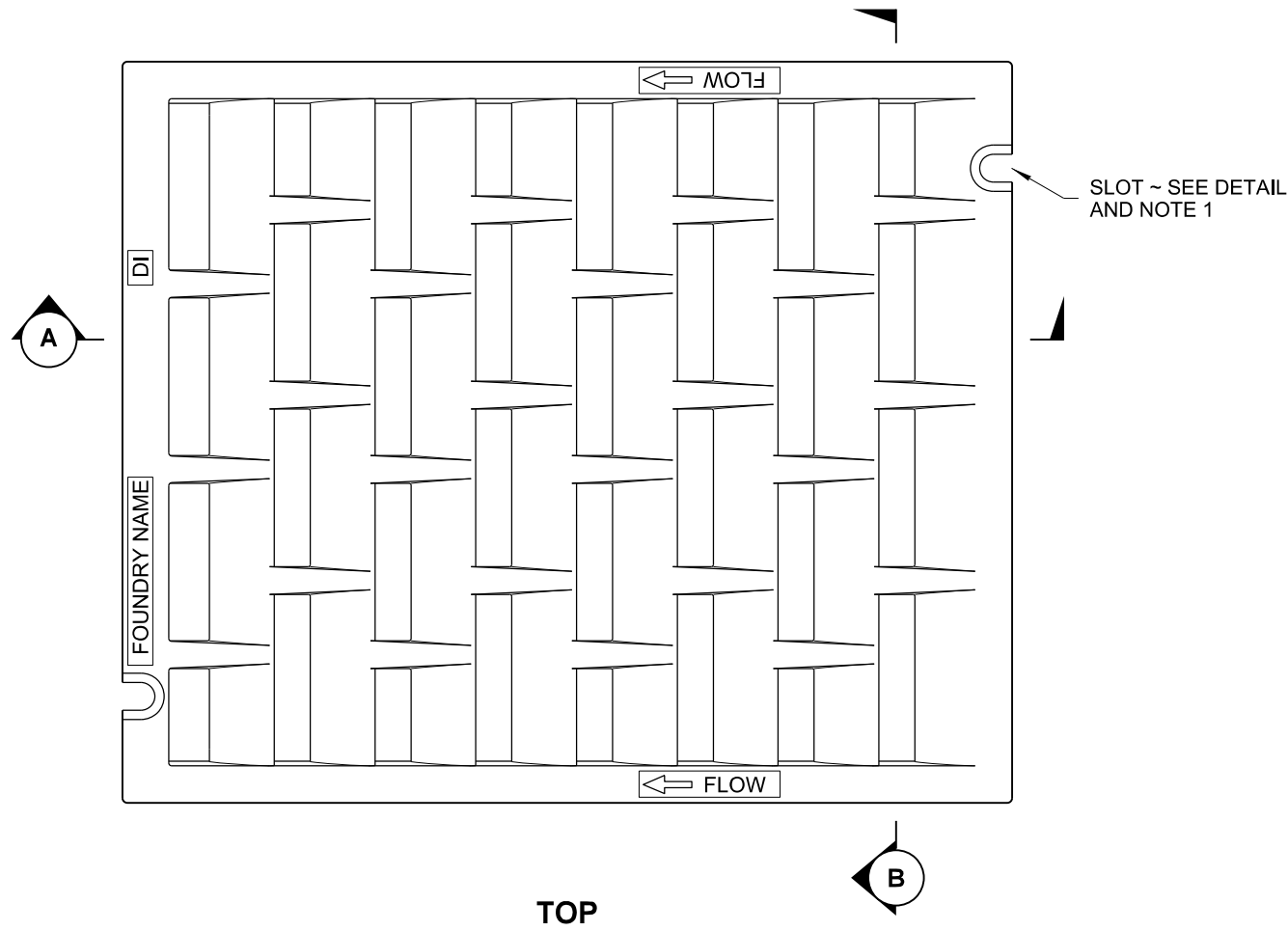

NOTES

1. Bolt-down capability is required on all frames, grates, and covers, unless specified otherwise in the Contract. Provide 2 holes in the frame that are vertically aligned with the grate or cover slots. The frame shall accept the 304 Stainless Steel (S.S.) 5/8" (in) - 11 NC x 2" (in) allen head cap screw by being tapped, or other approved mechanism. Location of bolt-down holes varies by manufacturer.
2. Refer to **Standard Specification Section 9-05.15** and **9-05.15(2)** for additional requirements.
3. For frame details, see **Standard Plan B-30.10**.

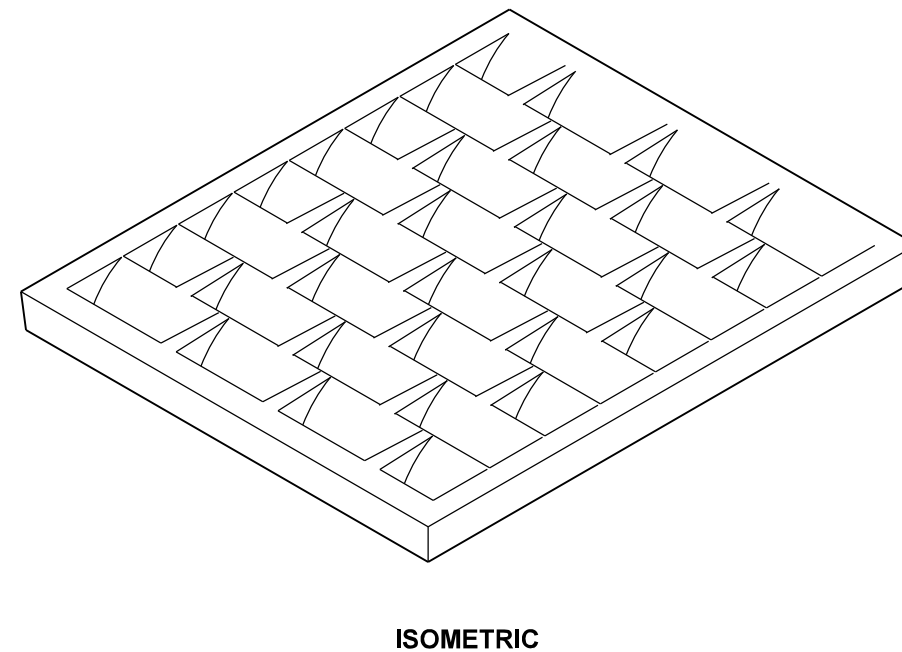
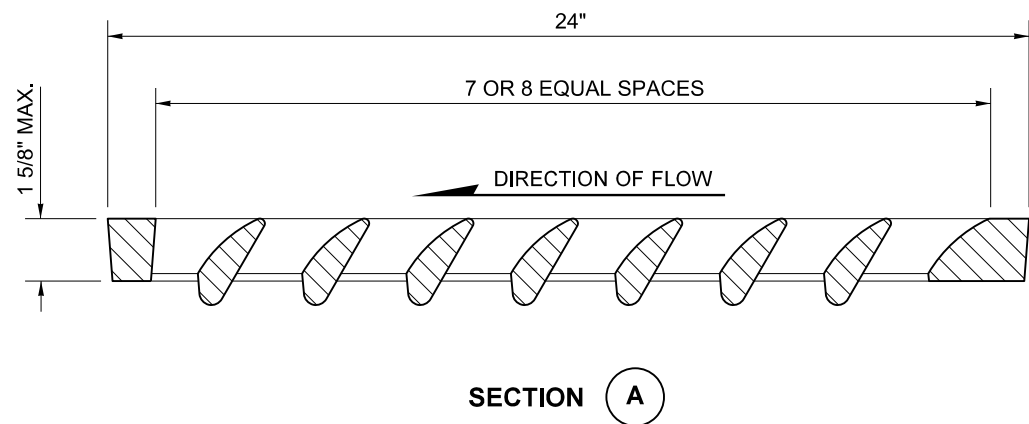
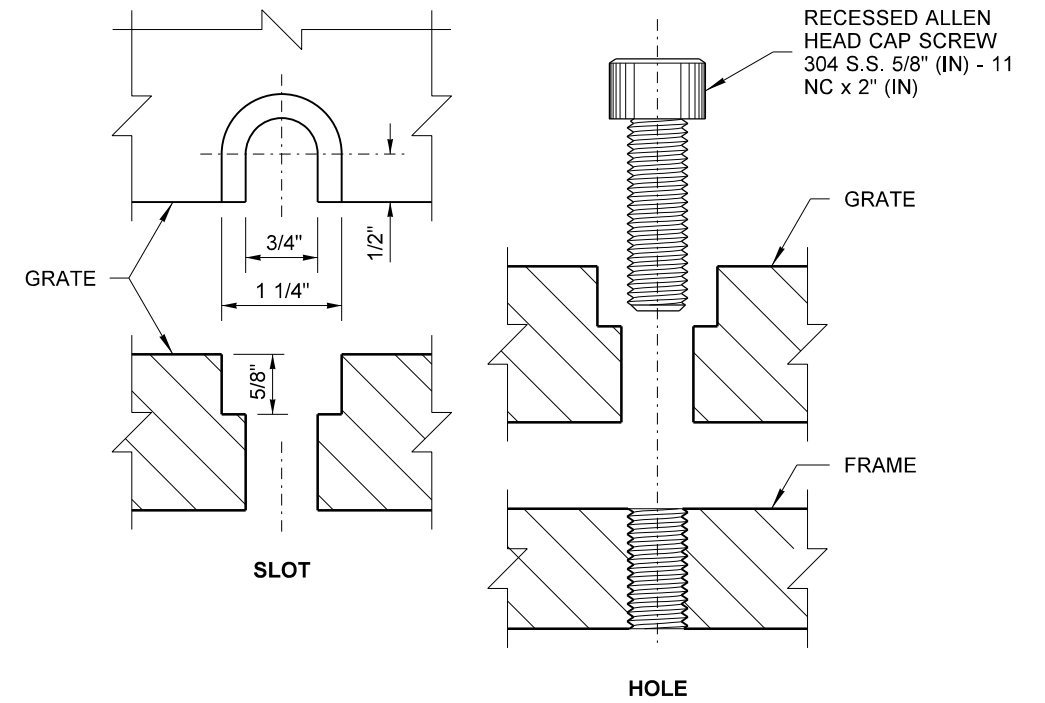

Heilman, Julie  
Feb 20 2018 12:54 PM

**RECTANGULAR VANED GRATE**  
**STANDARD PLAN B-30.30-03**

SHEET 1 OF 1 SHEET

APPROVED FOR PUBLICATION

Carpenter, Jeff  
Feb 27 2018 7:58 AM

STATE DESIGN ENGINEER

Washington State Department of Transportation

DRAWN BY: FERN LIDDELL

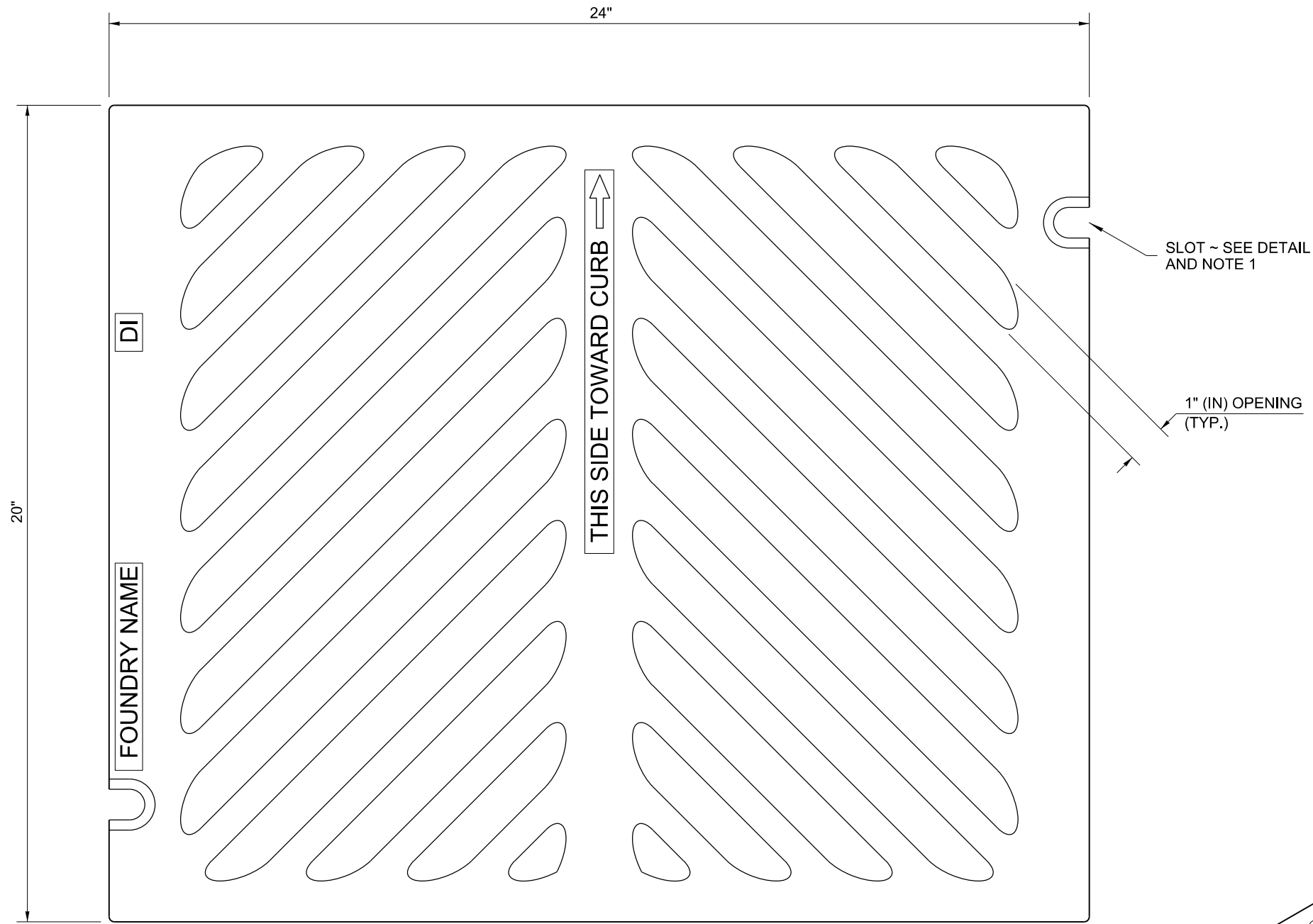

TOP

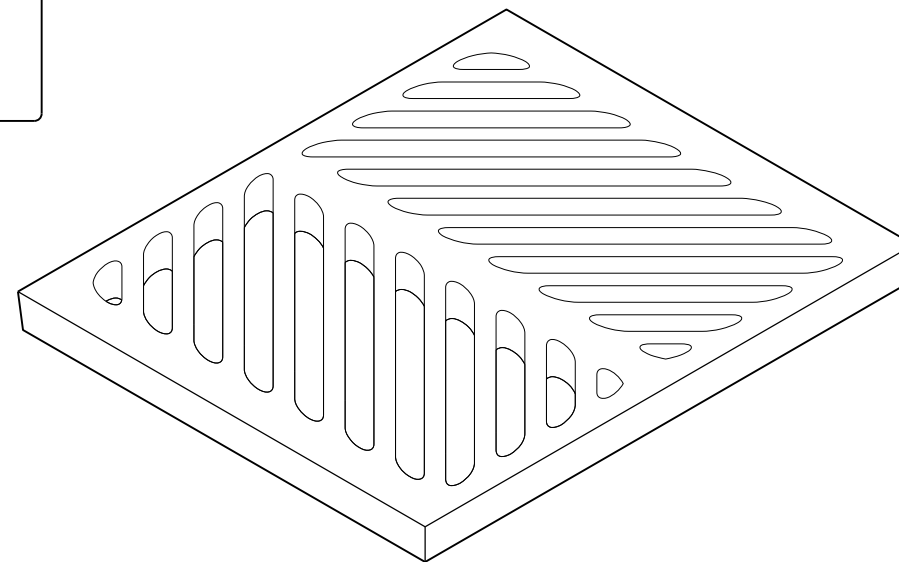

ISOMETRIC

NOTES

1. Bolt-down capability is required on all frames, grates, and covers, unless specified otherwise in the Contract. Provide 2 holes in the frame that are vertically aligned with the grate or cover slots. The frame shall accept the 304 Stainless Steel (S.S.) 5/8" (in) - 11 NC x 2" (in) allen head cap screw by being tapped, or other approved mechanism. Location of bolt-down holes varies by manufacturer.
2. Refer to **Standard Specification section 9-05.15**, and **9-05.15(2)** for additional requirements.
3. For frame details, see **Standard Plan B-30.10**.
4. The thickness of the grate shall not exceed 1 5/8" (in).

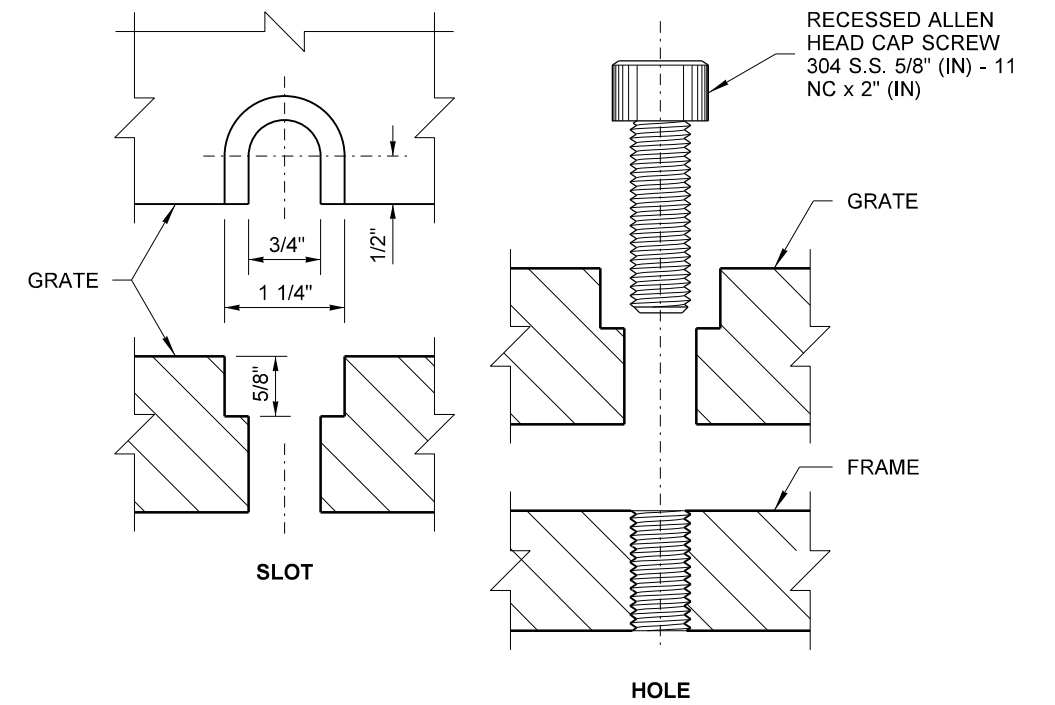

BOLT-DOWN DETAILS  
SEE NOTE 1



Heilman, Julie  
Feb 20 2018 12:55 PM

**RECTANGULAR  
HERRINGBONE GRATE**  
**STANDARD PLAN B-30.50-03**

SHEET 1 OF 1 SHEET

APPROVED FOR PUBLICATION

*EJH*  
Carpenter, Jeff  
Feb 27 2018 7:59 AM

STATE DESIGN ENGINEER



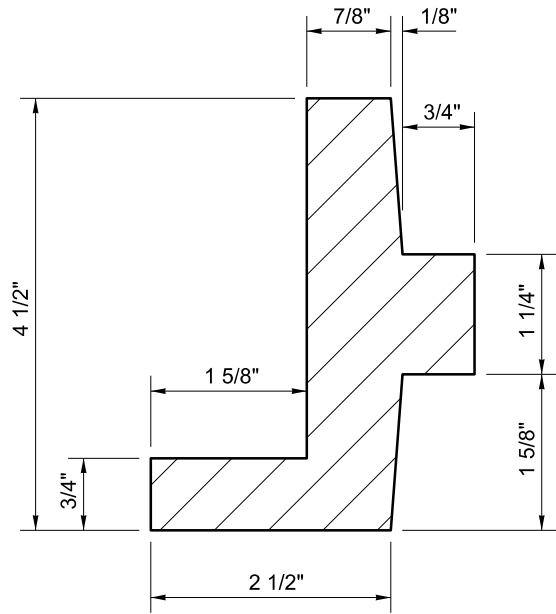
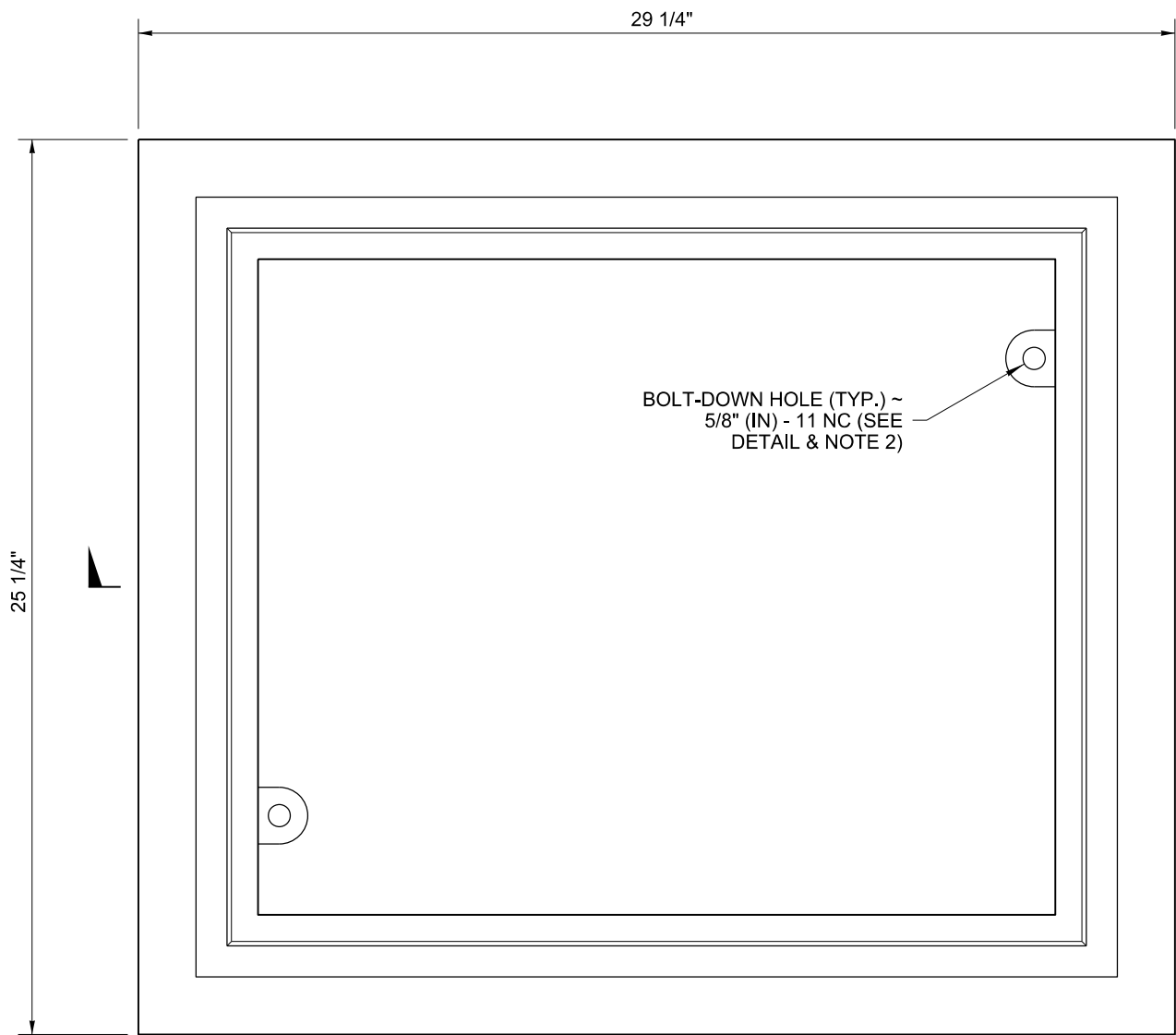

DETAIL B

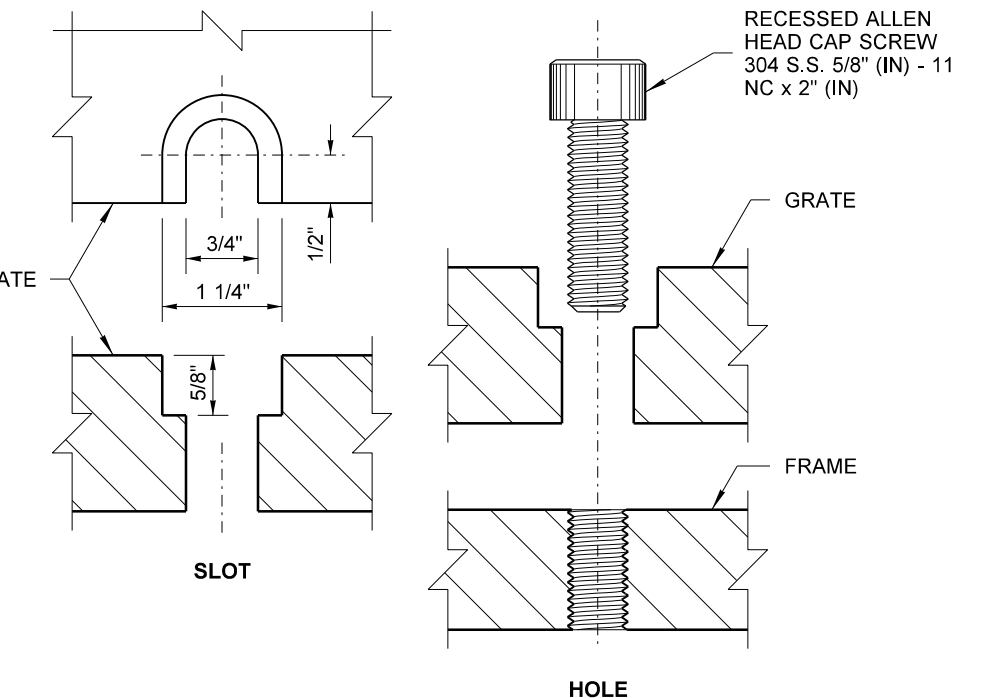

BOLT-DOWN DETAILS  
SEE NOTE 2

NOTES

1. This frame is designed to accommodate 20" (in) x 24" (in) grates or covers as shown on **Standard Plans B-30.20, B-30.30, B-30.40, and B-30.50.**
2. Bolt-down capability is required on all frames, grates, and covers, unless specified otherwise in the Contract. Provide 2 holes in the frame that are vertically aligned with the grate or cover slots. The frame shall accept the 304 Stainless Steel (S.S.) 5/8" (in) - 11 NC x 2" (in) allen head cap screw by being tapped, or other approved mechanism. Location of bolt-down holes varies by manufacturer.
3. Refer to **Standard Specification Section 9-05.15 and 9-05.15(2)** for additional requirements.

DRAWN BY: FERN LIDDELL

TOP

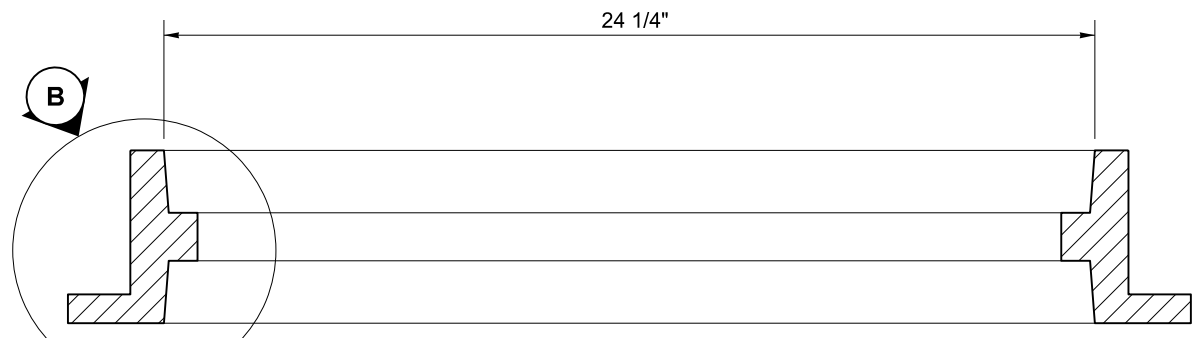

SECTION A

FRAME CAST INTO PRECAST  
ADJUSTMENT SECTION ~ SEE  
STANDARD PLAN B-30.90 FOR  
ADJUSTMENT SECTION DETAILS

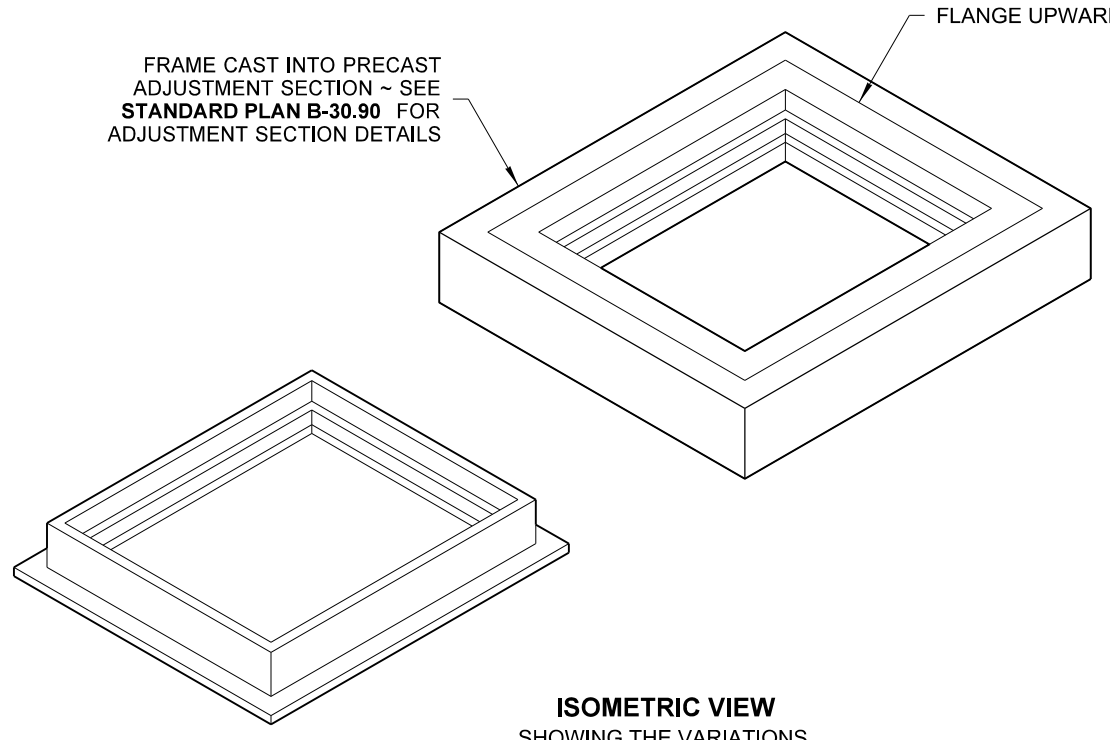

ISOMETRIC VIEW  
SHOWING THE VARIATIONS



Julie Heilman  
Heilman, Julie  
Feb 20 2018 12:52 PM

**RECTANGULAR FRAME  
(REVERSIBLE)**

**STANDARD PLAN B-30.10-03**

SHEET 1 OF 1 SHEET

APPROVED FOR PUBLICATION

Carpenter, Jeff  
Feb 27 2018 7:55 AM



STATE DESIGN ENGINEER  
Washington State Department of Transportation

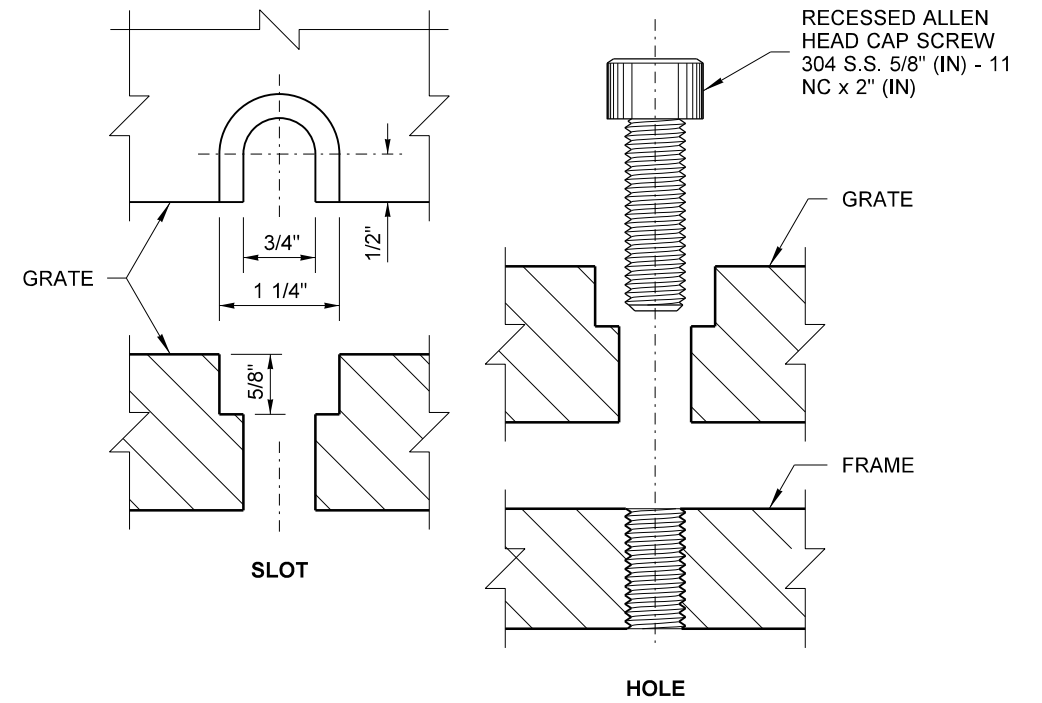
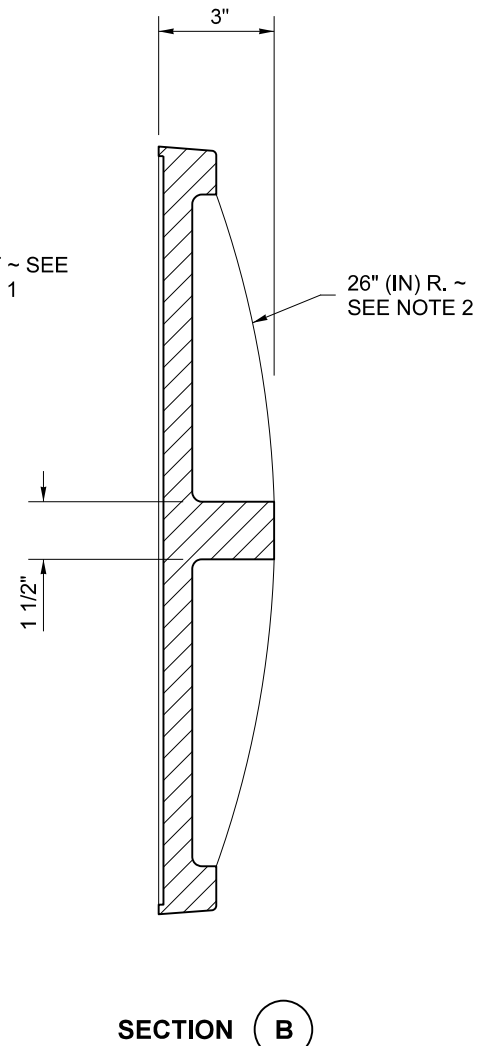
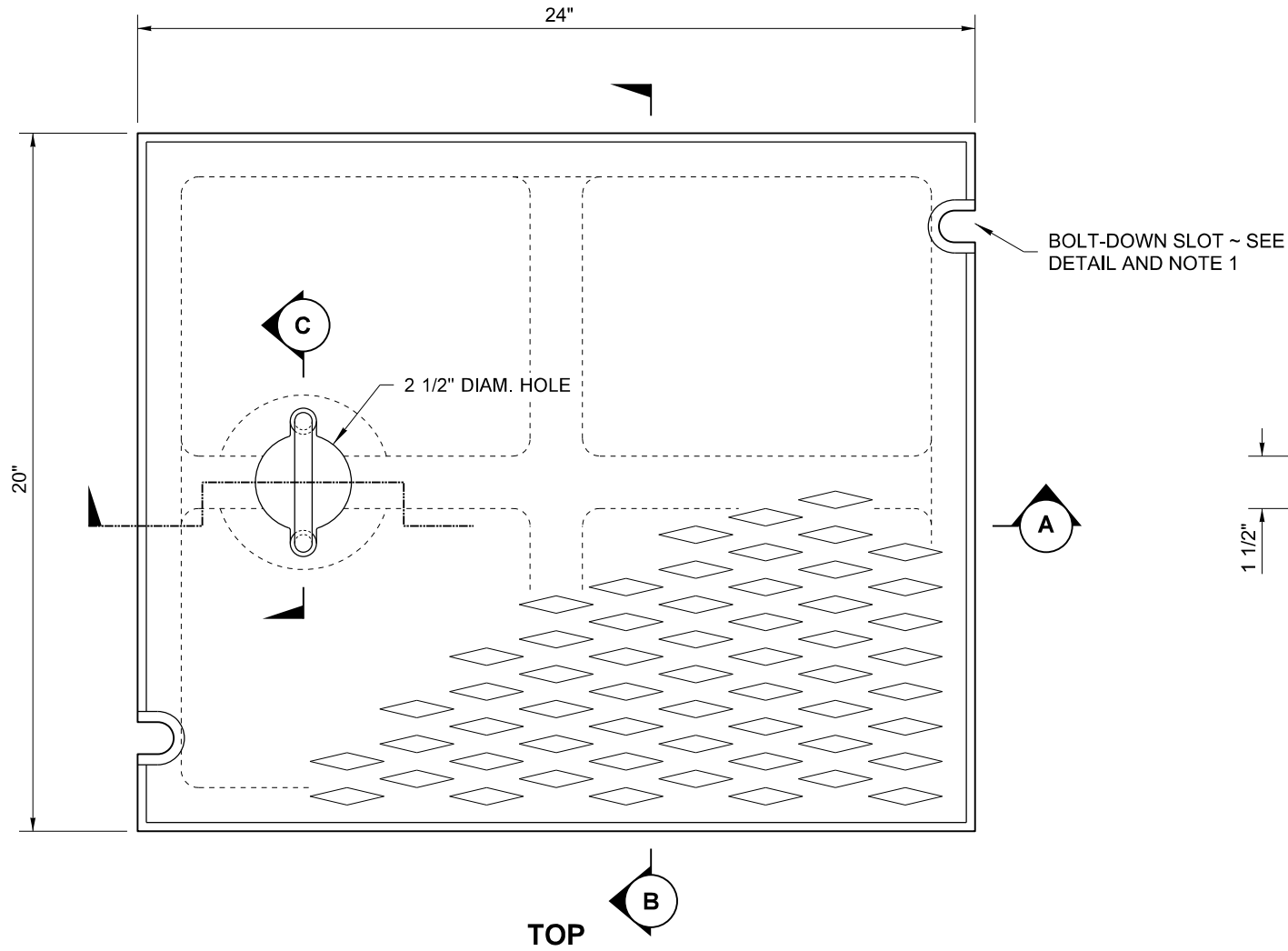

**BOLT-DOWN DETAILS**  
SEE NOTE 1

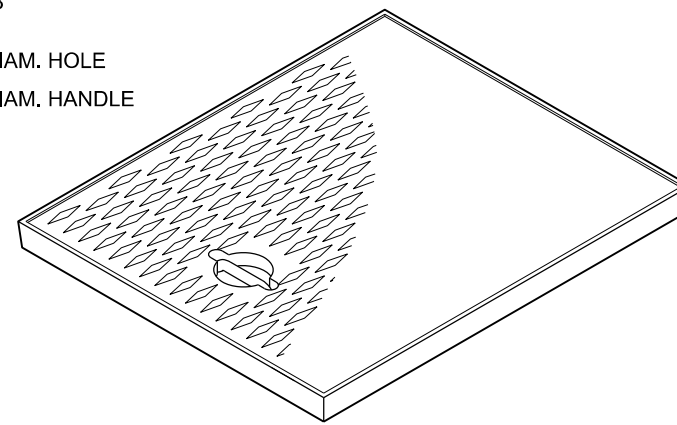
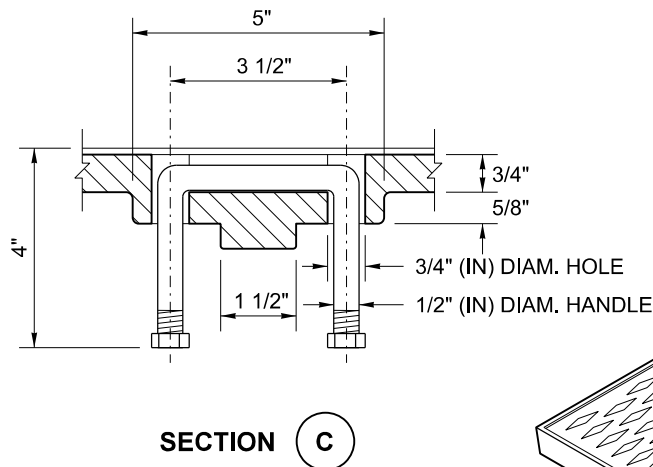
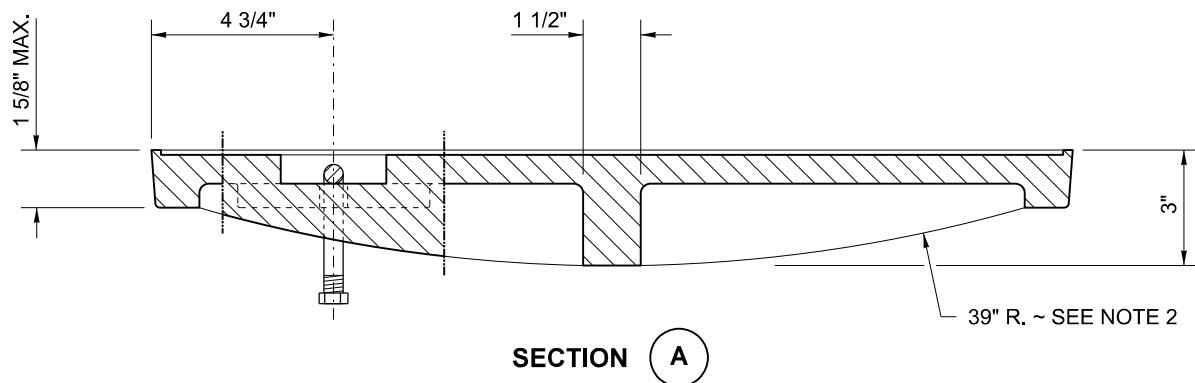

**ISOMETRIC**

**NOTES**

1. Bolt-down capability is required on all frames, grates, and covers, unless specified otherwise in the Contract. Provide 2 holes in the frame that are vertically aligned with the grate or cover slots. The frame shall accept the 304 Stainless Steel (S.S.) 5/8" (in) - 11 NC x 2" (in) allen head cap screw by being tapped, or other approved mechanism. Location of bolt-down holes varies by manufacturer.
2. Alternative reinforcing designs are acceptable in lieu of the rib design.
3. Refer to **Standard Specification Section 9-05.15** and **9-05.15(2)** for additional requirements.
4. For frame details, see **Standard Plan B-30.10**.



Julie Heilman  
Heilman, Julie  
Feb 20 2018 12:53 PM

**RECTANGULAR SOLID  
METAL COVER**

**STANDARD PLAN B-30.20-04**

SHEET 1 OF 1 SHEET

APPROVED FOR PUBLICATION

Carpenter, Jeff  
Feb 27 2018 7:57 AM



STATE DESIGN ENGINEER  
Washington State Department of Transportation

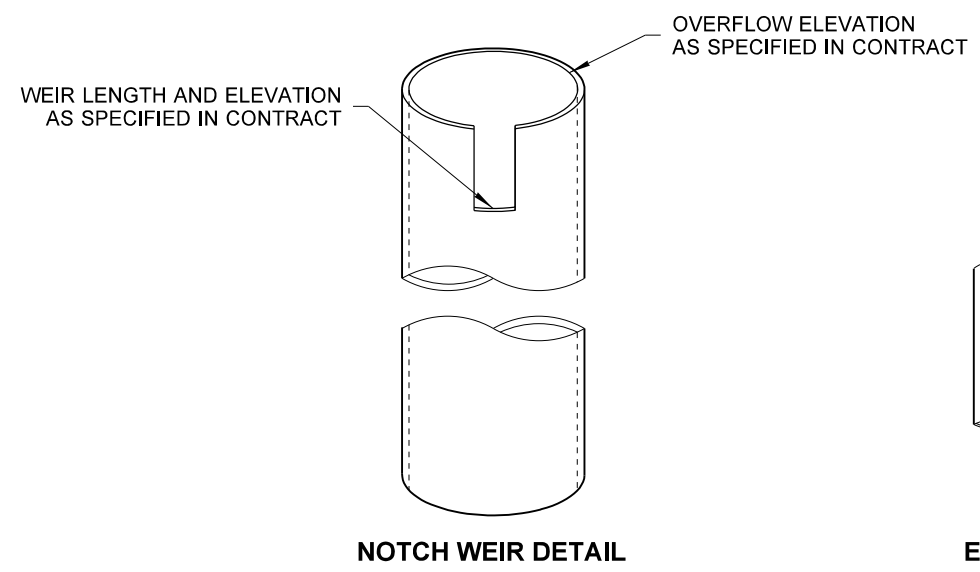
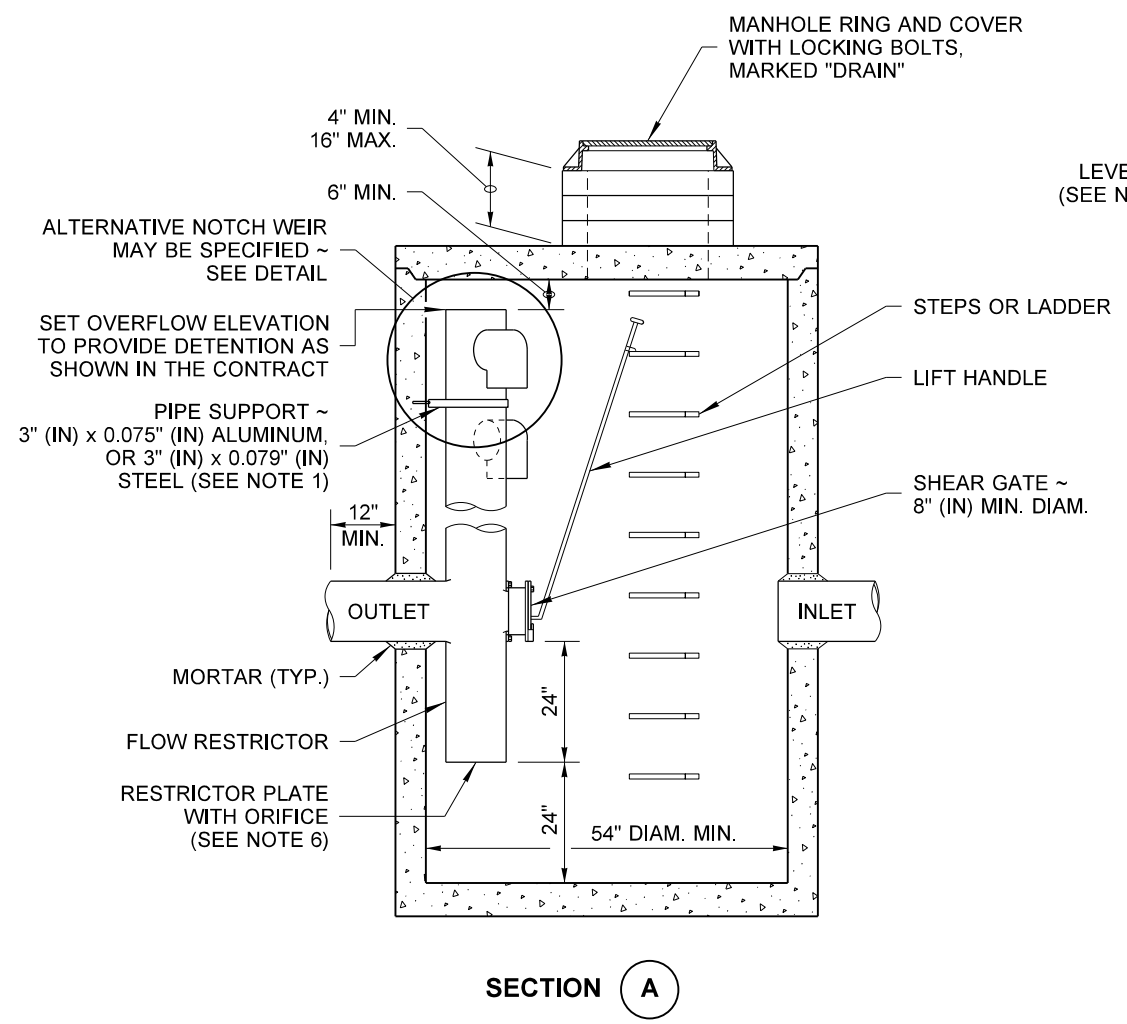
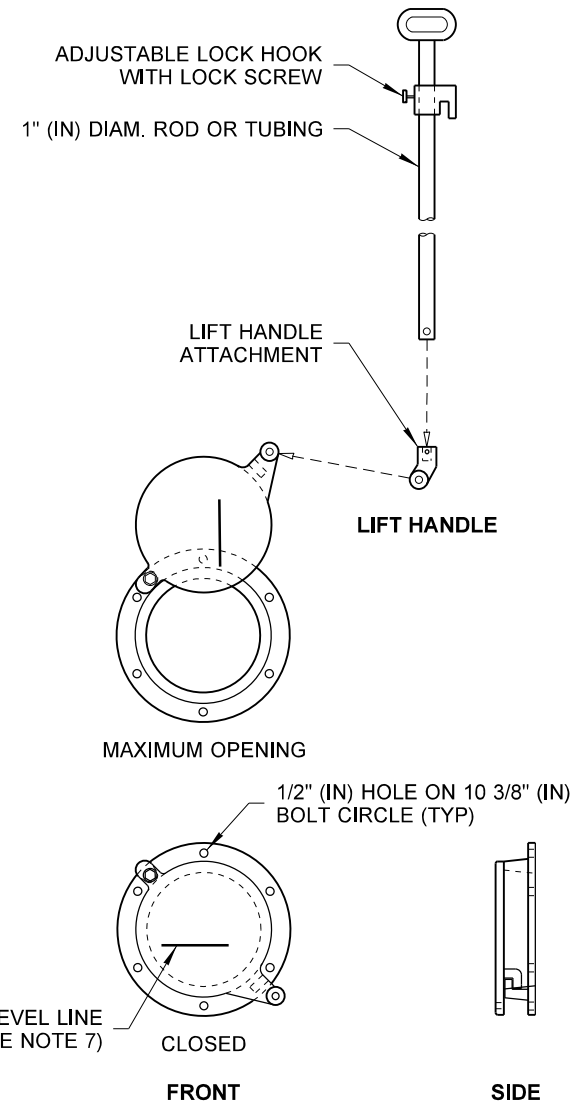
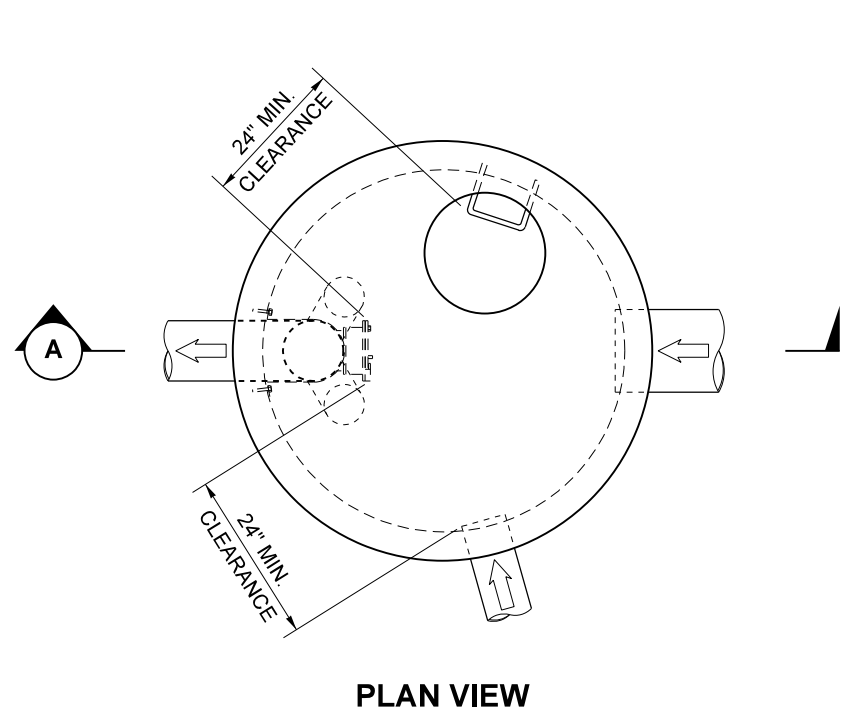

**NOTES**

- The pipe supports and the flow restrictor shall be constructed of the same material and be anchored at a maximum spacing of 36" (in). Attach the pipe supports to the manhole with 5/8" (in) stainless steel expansion bolts or embed the supports into the manhole wall 2" (in).
- The vertical riser stem of the flow restrictor shall be the same diameter as the horizontal outlet pipe with a minimum diameter of 8" (in).
- The flow restrictor shall be fabricated from one of the following materials:
  - 0.060" (in) Corrugated Aluminum Alloy Drain Pipe
  - 0.064" (in) Corrugated Galvanized Steel Drain Pipe with Treatment 1
  - 0.064" (in) Corrugated Aluminized Steel Drain Pipe
  - 0.060" (in) Aluminum alloy flat sheet, in accordance with **ASTM B 209, 5052 H32 or EPS**
  - High Density Polyethylene Storm Sewer Pipe
- The frame and ladder or steps are to be offset so that: the shear gate is visible from the top; the climb-down space is clear of the riser and gate; the frame is clear of the curb.
- The multi-orifice elbows may be located as shown, or all placed on one side of the riser to assure ladder clearance. The size of the elbows and their placement shall be specified in the Contract.
- Restrictor plate with orifice as specified in the Contract. The opening is to be cut round and smooth.
- The shear gate shall be made of aluminum alloy in accordance with **ASTM B 26 and ASTM B 275, designation ZG32A**; or cast iron in accordance with **ASTM A 48, Class 30B**.  
 The lift handle shall be made of a similar metal to the gate (to prevent galvanic corrosion), it may be of solid rod or hollow tubing, with adjustable hook as required.  
 A neoprene rubber gasket is required between the riser mounting flange and the gate flange.  
 Install the gate so that the level-line mark is level when the gate is closed.  
 The mating surfaces of the lid and the body shall be machined for proper fit.  
 All shear gate bolts shall be stainless steel.
- The shear gate maximum opening shall be controlled by limited hinge movement, a stop tab, or some other device.
- Alternative shear gate designs are acceptable if material specifications are met.



Heilman, Julie  
Jan 25 2017 2:57 PM

**CATCH BASIN TYPE 2  
WITH FLOW RESTRICTOR**

**STANDARD PLAN B-10.40-01**

SHEET 1 OF 1 SHEET

APPROVED FOR PUBLICATION  
Carpenter, Jeff  
Jan 26 2017 6:49 AM

STATE DESIGN ENGINEER  
Washington State Department of Transportation

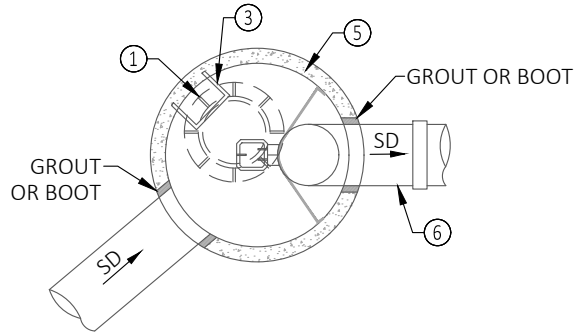

**PLAN**

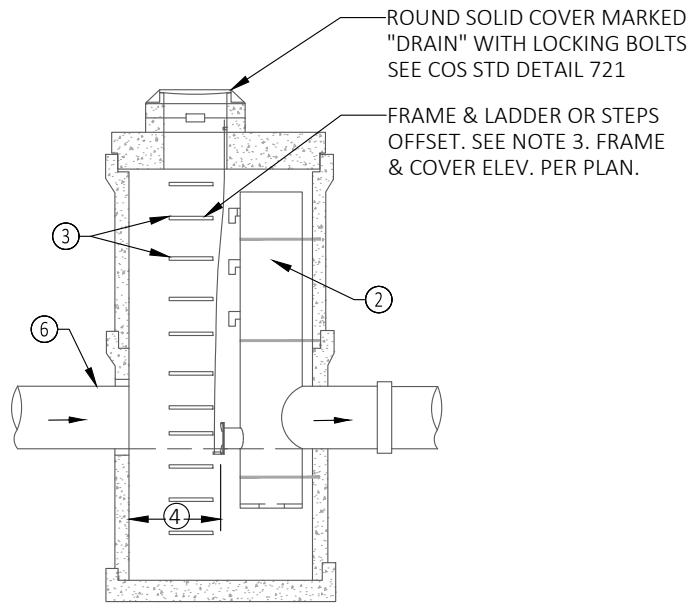

**ELEVATION**

**NOTES:**

- ① INSTALL 1-24" DIA. MH. ACCESS PER WSDOT STD DETAIL B-30.90-02, SO THAT THE LIFT GATE IS VISIBLE AND THE STEPS ARE CLEAR AND DIRECTLY ACCESSIBLE.
- ② FLOW RESTRICTOR UNIT - SEE COS STD DETAIL 761.
- ③ POLYPROPLENE PLASTIC STEP OR LADDER, SEE WSDOT STD DETAIL B-30.90-02, OFFSET STEPS OR LADDER FROM FRAME SO THAT:
  - A. CLEANOUT GATE IS VISIBLE FROM TOP.
  - B. CLIMB DOWN SPACE IS CLEAR OF RISER AND CLEANOUT GATE.
  - C. FRAME IS CLEAR OF CURB.
- ④ MIN CLEARANCE: 36" FOR OUTLETS OF 24" AND LARGER 18" FOR OUTLETS OF 18" AND SMALLER.
- ⑤ 54" OR 60" TYPE 2 CB.
- ⑥ SEE PLAN AND SPECIFICATIONS FOR SIZE AND TYPE OF PIPES ENTERING AND EXITING CB.

*Tricia Juhnke*

APPROVED BY: TRICIA JUHNKE  
CITY ENGINEER



STANDARD DETAIL NUMBER: **760** SCALE: **NOT TO SCALE**

**CONTROL STRUCTURE**

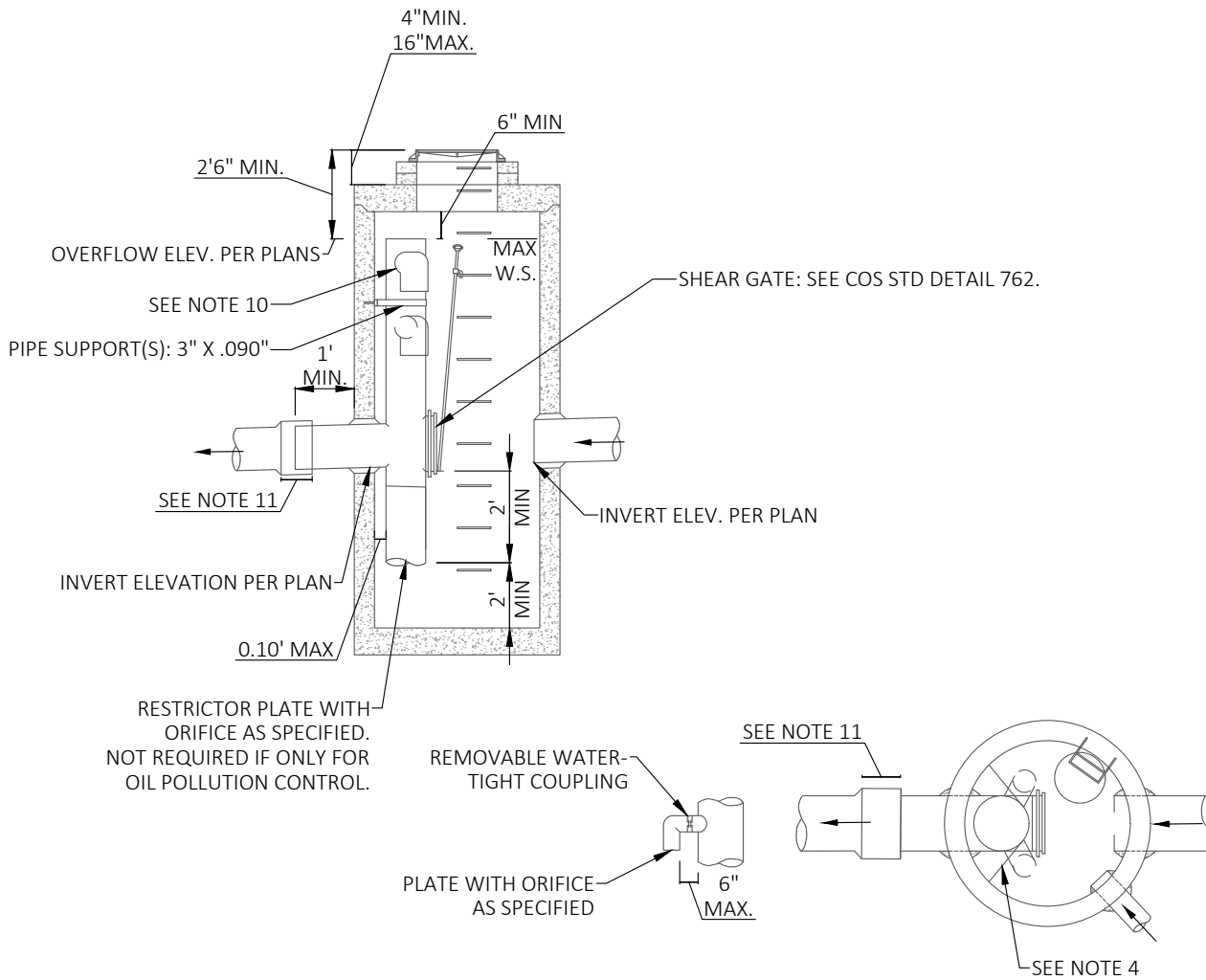

**NOTES:**

1. PIPE SIZES AND SLOPES: PER PLANS.
2. OUTLET CAPACITY: NOT LESS THAN COMBINED INLETS.
3. EXCEPT AS SHOWN OR NOTED, UNITS SHALL BE CONSTRUCTED IN ACCORDANCE WITH THE REQUIREMENTS FOR CATCH BASIN TYPE 2, 54" MIN. DIAM.
4. PIPE SUPPORTS SHALL BE STAINLESS STEEL, AND BE ANCHORED AT 3' MAX. SPACING BY 5/8" DIAM. STAINLESS STEEL EXPANSION BOLTS OR EMBEDDED 2" IN WALL. ONE STRAP ABOVE AND BELOW OUTLET REQUIRED, INTERMEDIATE STRAPS REQUIRED FOR RESTRICTOR RISERS GREATER THAN 12' ABOVE OUTLET.
5. THE RESTRICTOR/SEPARATOR SHALL BE FABRICATED FROM .060" ALUMINUM, OR .064" ALUMINIZED STEEL.
6. OUTLET SHALL BE CONNECTED TO CULVERT OR STORM DRAIN WITH A STANDARD COUPLING BAND FOR CORRUGATED METAL PIPE, OR GROUTED INTO THE BELL OF CONCRETE PIPE.
7. THE VERTICAL RISER STEM OF THE RESTRICTOR/SEPARATOR SHALL BE THE SAME DIAM. AS THE HORIZONTAL OUTLET PIPE, WITH AN 8" MIN. DIAM.
9. IF METAL OUTLET PIPE CONNECTS TO CEMENT CONCRETE PIPE: OUTLET PIPE TO HAVE SMOOTH O.D. EQUAL TO CONCRETE PIPE I.D. LESS 1/4".
10. MULTI-ORIFICE ELBOWS MAY BE LOCATED AS SHOWN OR ALL ON ONE SIDE OF RISER TO ASSURE LADDER CLEARANCE.
11. BAND STRAP WITH GASKET.

**ELBOW DETAIL**

**PLAN**

*Tricia Juhnke*

APPROVED BY: TRICIA JUHNKE  
CITY ENGINEER



STANDARD DETAIL NUMBER: **761** SCALE: **NOT TO SCALE**

**FLOW RESTRICTOR**

PUBLICATION DATE: 03/01/2020 REVISION DATE: 02/11/2020



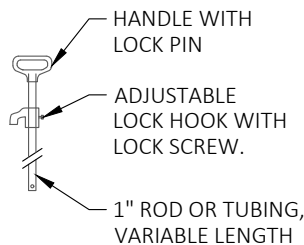
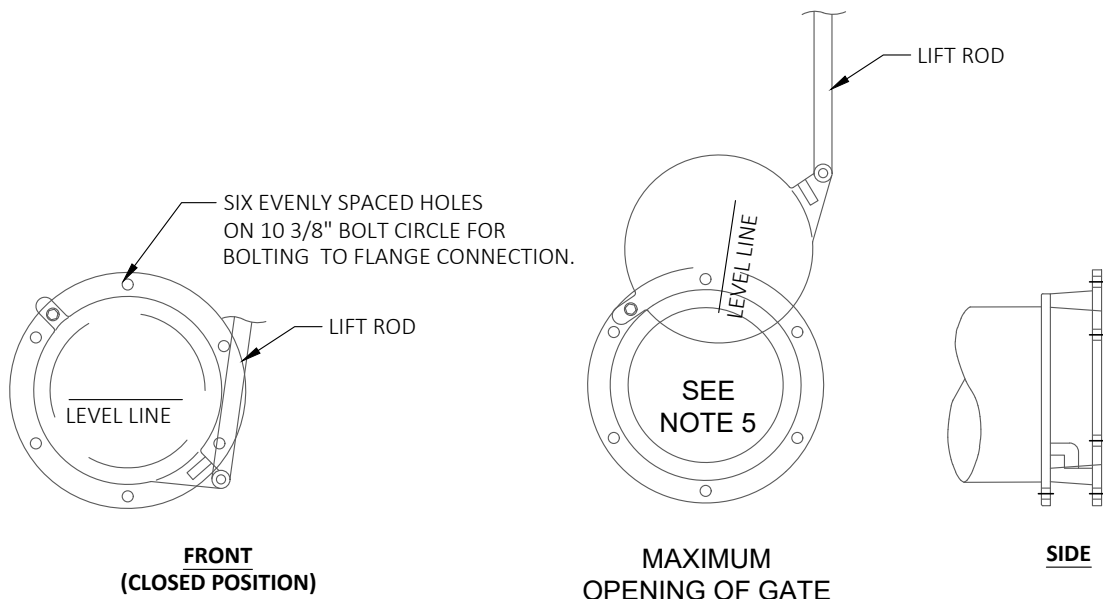

**LIFT HANDLE**

**NOTES:**

1. SHEAR GATE SHALL BE ALUMINUM ALLOY PER ASTM B-26-ZG-32a OR CAST IRON ASTM A48 CLASS 308 AS REQUIRED.
2. GATE SHALL BE 8" DIAMETER UNLESS OTHERWISE SPECIFIED.
3. GATE SHALL BE JOINED TO TEE SECTION BY BOLTING (THROUGH FLANGE) OR WELDED.
4. LIFT ROD: AS SPECIFIED BY MANUFACTURER WITH HANDLE EXTENDING TO WITHIN 1 FOOT OF COVER & ADJUSTABLE HOOK LOCK FASTENED TO FRAME OR UPPER HANDHOLD.
5. GATE SHALL NOT OPEN BEYOND THE CLEAR OPENING BY LIMITED HINGE MOVEMENT, STOP TAB, OR SOME OTHER DEVICE.
6. NEOPRENE RUBBER GASKET REQUIRED BETWEEN RISER MOUNTING FLANGE AND GATE FLANGE.
7. MATING SURFACES OF LID AND BODY TO BE MACHINED FOR PROPER FIT.
8. FLANGE MOUNTING BOLTS SHALL BE 3/8" DIAMETER STAINLESS STEEL.
9. ALTERNATIVE CLEANOUT/SHEAR GATES TO THE DESIGN SHOWN ARE ACCEPTABLE, PROVIDED THEY MEET THE MATERIAL SPECIFICATIONS ABOVE AND HAVE A SIX BOLT, 10 3/8" BOLT CIRCLE FOR BOLTING TO THE FLANGE CONNECTION.

*Tricia Juhnke*

APPROVED BY: TRICIA JUHNKE  
CITY ENGINEER



STANDARD DETAIL NUMBER: **762** SCALE: **NOT TO SCALE**

**SHEAR GATE**

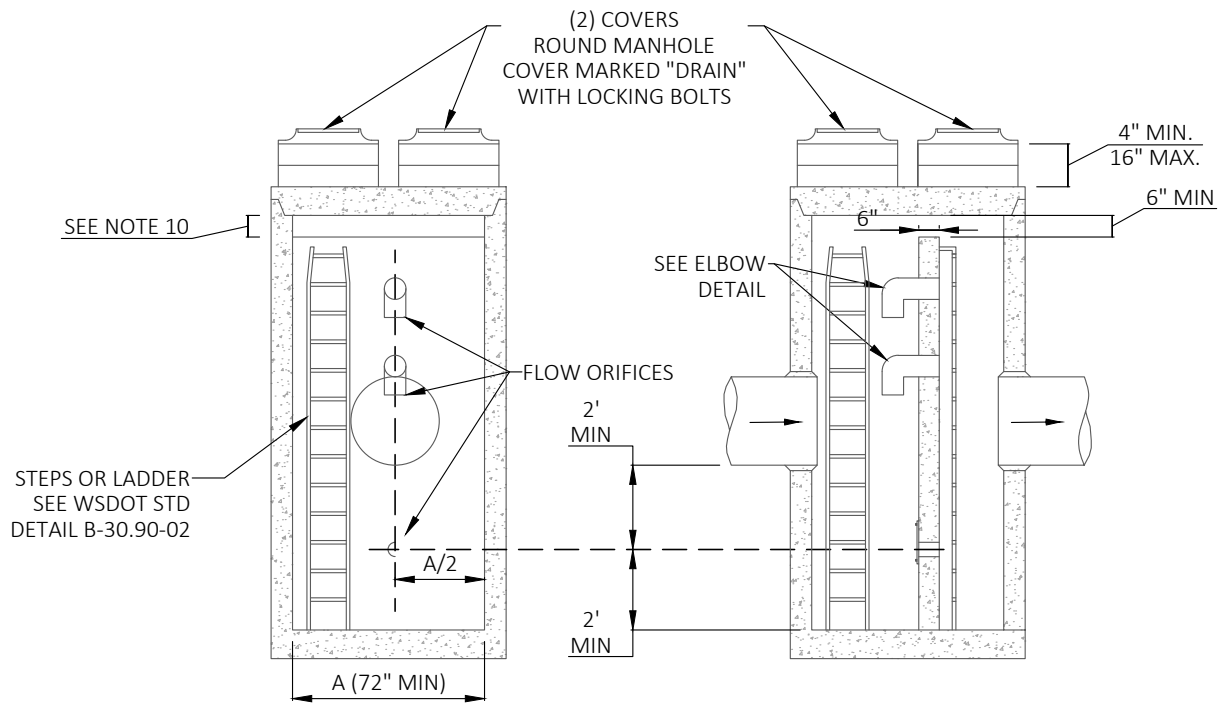

SECTION A-A

SECTION B-B

**ELEVATION**

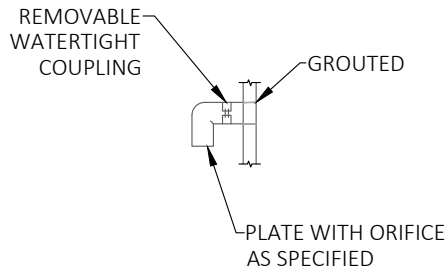

**ELBOW DETAIL**

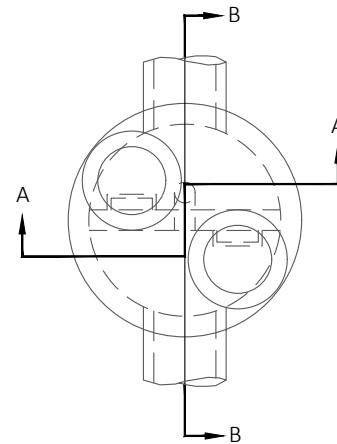

**PLAN**

**NOTES:**

1. PIPE SIZE, SLOPES, AND ALL ELEVATIONS: PER PLANS.
2. OUTLET CAPACITY: NOT LESS THAN COMBINED INLETS.
3. CATCH BASIN: TYPE 2 TO BE CONSTRUCTED IN ACCORDANCE WITH WSDOT STD DETAIL B-10.20-02& AASHTO M199 UNLESS OTHERWISE SPECIFIED.
4. COVERS: ROUND, SOLID MARKED "DRAIN" WITH LOCKING BOLTS. SEE WSDOT STD DETAIL B-30.70-04.
5. ORIFICES: SIZED & LOCATED AS REQUIRED, WITH LOWEST ORIFICE MIN 2" FROM BASE.
6. BAFFLE WALL SHALL HAVE #4 REINFORCEMENT BAR AT 12" SPACING EACH WAY.
7. PRECAST BAFFLE WALL SHALL BE KEYED & GROUTED IN PLACE.
8. BOTTOM ORIFICE PLATE TO BE 1/4" MIN ALUMINUM & ATTACHED WITH 1/2" STAINLESS STEEL BOLTS. OMIT ORIFICE PLATE ID ONLY FOR OIL SEPARATION.
9. THE RESTRICTOR/SEPARATOR SHALL BE FABRICATED FROM .060" ALUMINUM.

*Tricia Juhnke*

APPROVED BY: TRICIA JUHNKE  
CITY ENGINEER



STANDARD DETAIL NUMBER: **763** SCALE: **NOT TO SCALE**

**FLOW RESTRICTOR (BAFFLE)**

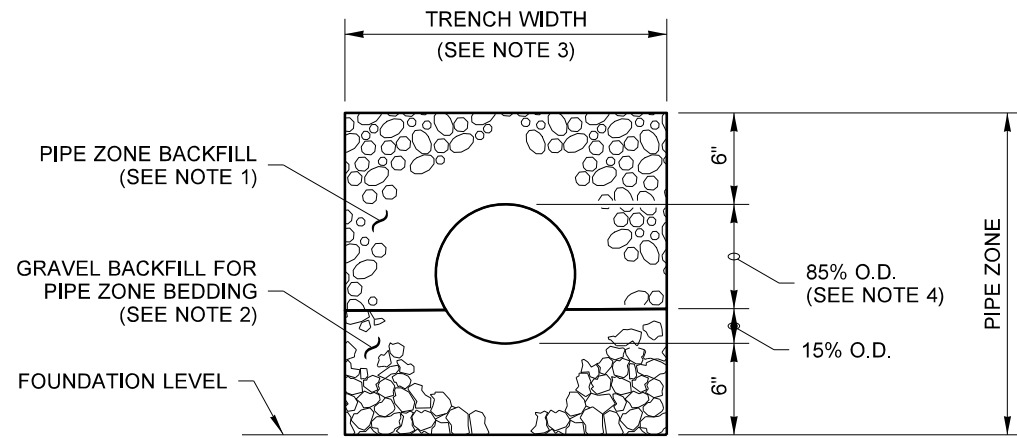

**CONCRETE AND DUCTILE IRON PIPE**

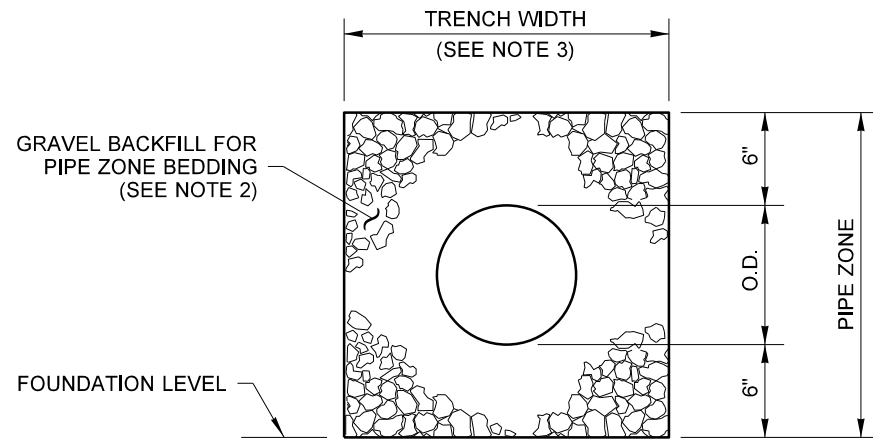

**THERMOPLASTIC PIPE**

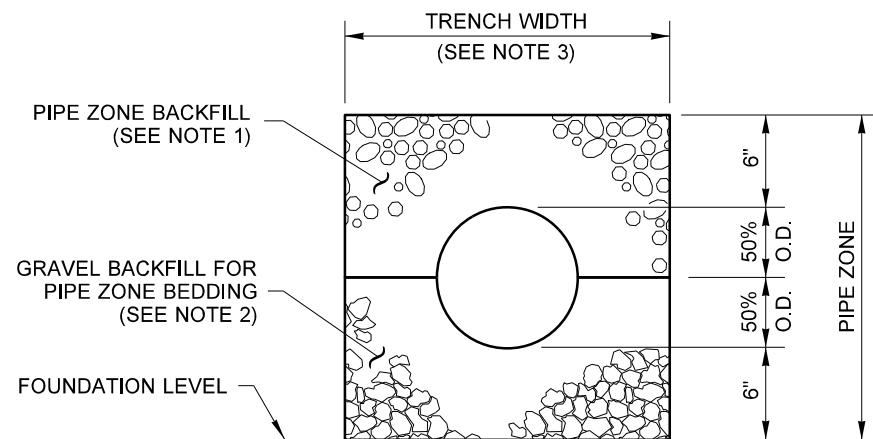

**METAL AND STEEL RIB REINFORCED POLYETHYLENE PIPE**

**NOTES**

1. See **Standard Specifications Section 7-08.3(3)** for Pipe Zone Backfill.
2. See **Standard Specifications Section 9-03.12(3)** for Gravel Backfill for Pipe Zone Bedding.
3. See **Standard Specifications Section 2-09.4** for Measurement of Trench Width.
4. For sanitary sewer installation, concrete pipe shall be bedded to spring line.

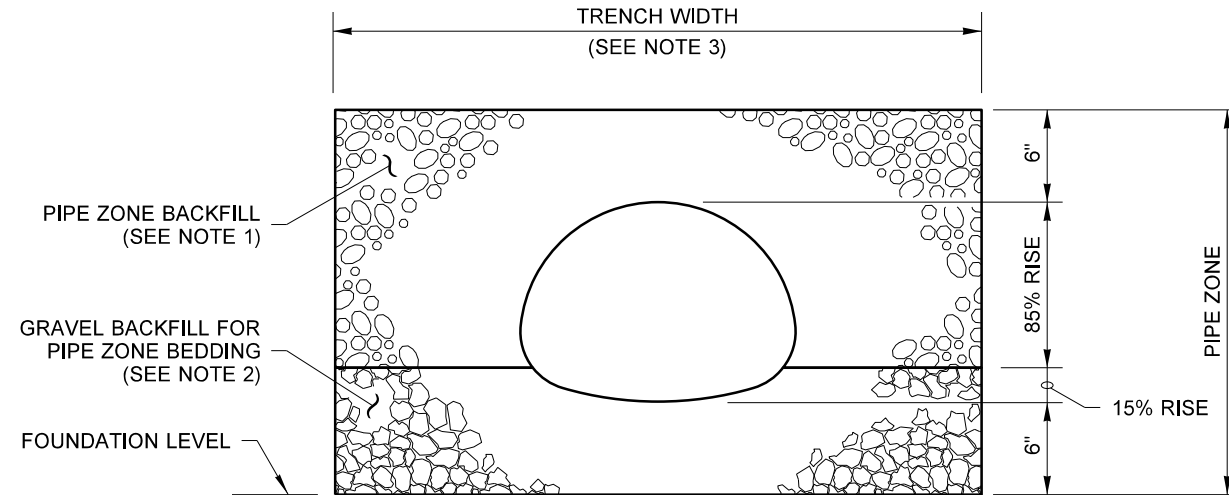

**PIPE ARCHES**

CLEARANCE BETWEEN PIPES FOR MULTIPLE INSTALLATIONS		
PIPE	SIZE	MINIMUM DISTANCE BETWEEN BARRELS
CIRCULAR PIPE (DIAMETER)	UP TO 48"	24"
METAL PIPE ARCH (SPAN)	48" AND LARGER	DIAMETER/2 OR 36" WHICHEVER IS LESS



Heilman, Julie  
Feb 20 2018 12:56 PM

**PIPE ZONE BEDDING AND BACKFILL**

**STANDARD PLAN B-55.20-02**

SHEET 1 OF 1 SHEET

APPROVED FOR PUBLICATION

Carpenter, Jeff  
Feb 27 2018 8:01 AM

STATE DESIGN ENGINEER



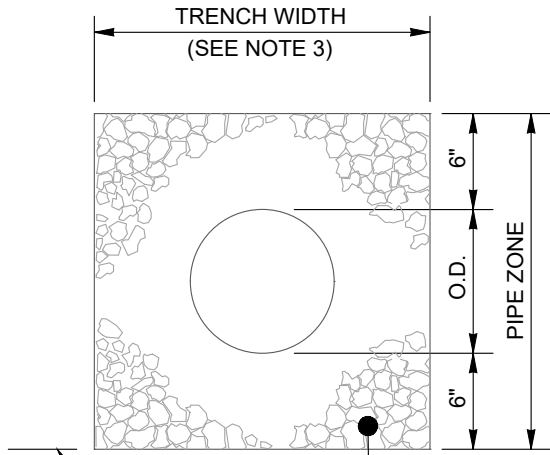

FOUNDATION LEVEL  
GRAVEL BACKFILL FOR PIPE ZONE BEDDING (SEE NOTE 2)

**THERMOPLASTIC PIPE**

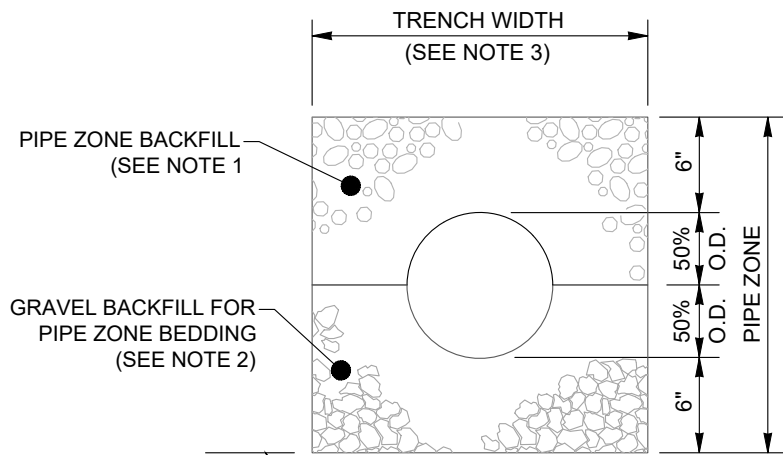

PIPE ZONE BACKFILL (SEE NOTE 1)  
GRAVEL BACKFILL FOR PIPE ZONE BEDDING (SEE NOTE 2)

FOUNDATION LEVEL

**METAL AND STEEL RIB REINFORCED POLYETHYLENE PIPE**

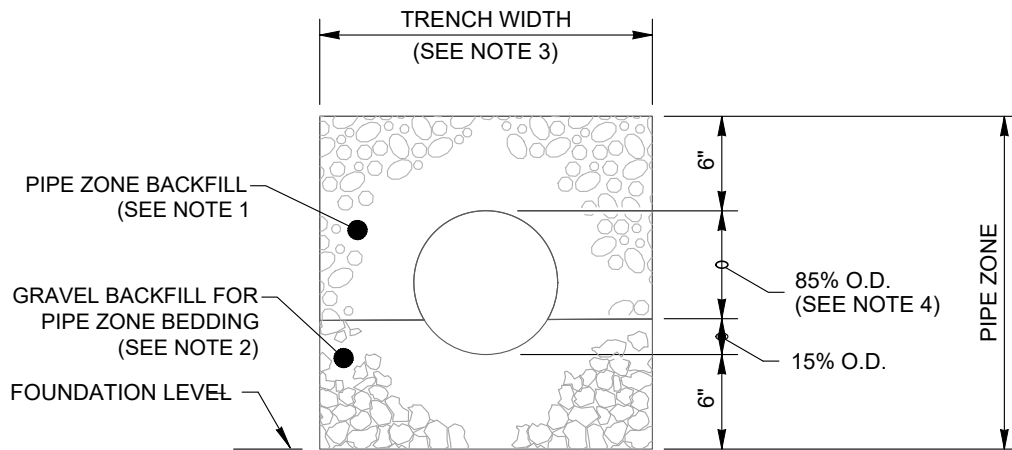

PIPE ZONE BACKFILL (SEE NOTE 1)  
GRAVEL BACKFILL FOR PIPE ZONE BEDDING (SEE NOTE 2)  
FOUNDATION LEVEL

85% O.D. (SEE NOTE 4)  
15% O.D.

**CONCRETE AND DUCTILE IRON PIPE**

NOTES

1. See **WSDOT Standard Specifications Section 7-08.3(3)** for Pipe Zone Backfill.
2. See **WSDOT Standard Specifications Section 9-03.12(3)** for Gravel Backfill for Pipe Zone Bedding.
3. See **WSDOT Standard Specifications Section 2-09.4** for Measurement of Trench Width.
4. For sanitary sewer installation, pipe shall be bedded to spring line.

*Tricia Juhnke*

APPROVED BY: TRICIA JUHNKE  
CITY ENGINEER



STANDARD DETAIL NUMBER: **773** SCALE: **NOT TO SCALE**

**PIPE ZONE BEDDING AND BACKFILL**

PUBLICATION DATE: 03/01/2020 REVISION DATE: 02/11/2020

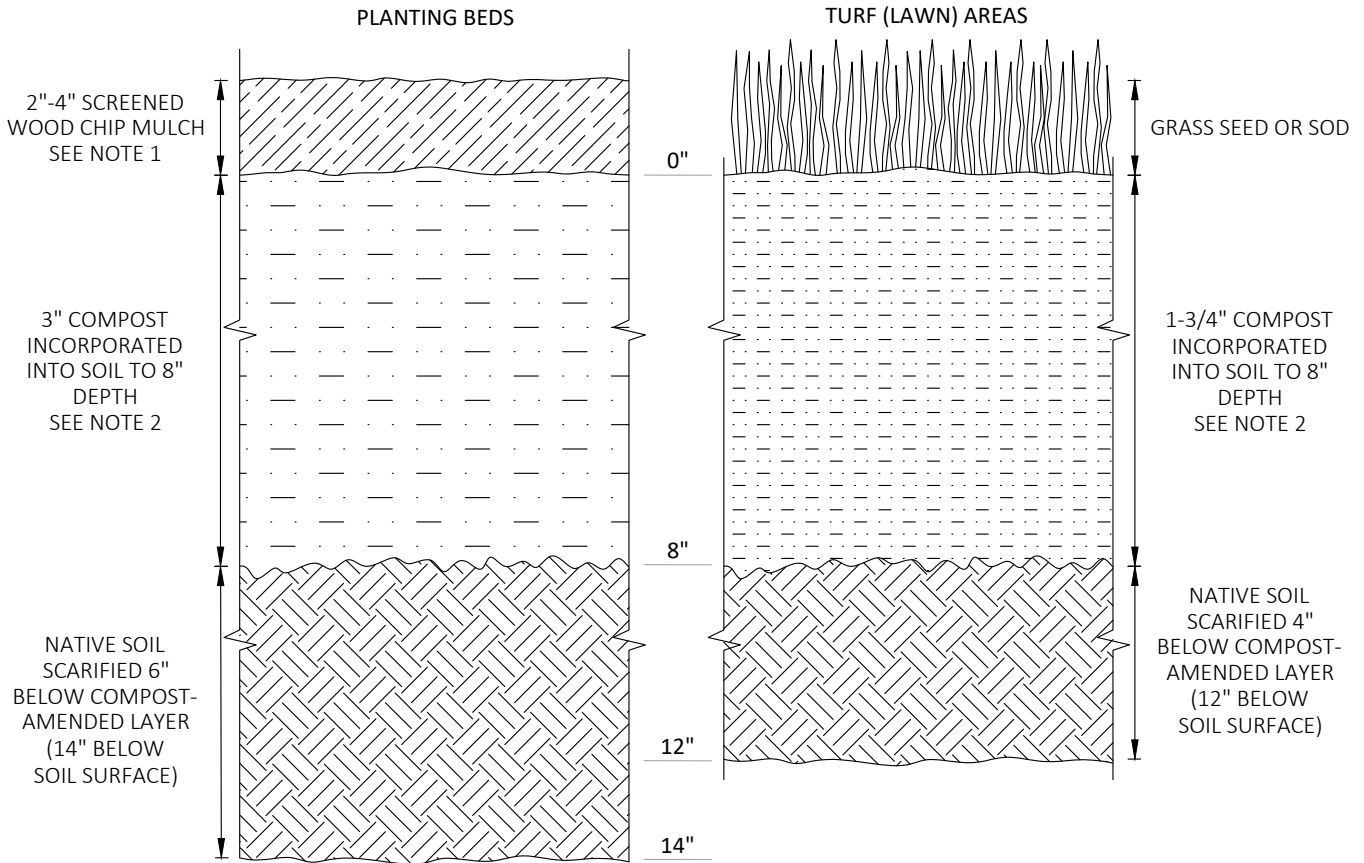

**SECTION VIEW**

**NOTES:**

1. WOOD CHIP MULCH SHALL MEET WSDOT STD SPEC 9-14.5(3).
2. COMPOST SHALL MEET WSDOT STD SPEC 9-14.5(8).
3. ALL SOIL AREAS DISTURBED OR COMPACTED DURING CONSTRUCTION AND NOT COVERED BY BUILDINGS OR PAVEMENT SHALL BE AMENDED WITH COMPOST TO A MINIMUM 8" DEPTH. SUBSOIL SHALL SCARIFIED 4" BELOW THAT COMPOST-AMENDED LAYER FOR A FINISHED 12" OF UN-COMPACTED DEPTH IN ALL LANDSCAPE AREAS.
4. COMPOST SHALL BE TILLED INTO 8" DEPTH INTO EXISTING SOIL, OR PLACE 8" OF COMPOST-AMENDED SOIL, PER SOIL SPECIFICATION. SUBSOIL SHALL BE SCARIFIED (LOOSENE) BELOW AMENDED LAYER TO PRODUCE OF UN-COMPACTED SOIL, EXCEPT WHERE SCARIFICATION WOULD DAMAGE TREE ROOTS.
5. TURF AREAS SHALL RECEIVE 1.75" OF COMPOST TILLED INTO 8" DEPTH, OR PLACE 8" OF IMPORTED SOIL CONTAINING 20-25% COMPOST BY VOLUME. THEN PLANT GRASS SEED OR SOD PER SPECIFICATIONS.
6. PLANTING BEDS SHALL RECEIVE 3" OF COMPOST TILLED INTO 8" DEPTH, OR PLACE 8" OF IMPORTED SOIL CONTAINING 35-40% COMPOST BY VOLUME. MULCH AFTER PLANTING, WITH 2-4" OF ARBORIST WOOD CHIP MULCH OR APPROVED EQUAL.
7. RAKE BEDS TO SMOOTH AND REMOVE SURFACE ROCKS LARGER THAN 2" DIAMETER.
8. DO NOT SCARIFY WITHIN DRIPLINE OF EXISTING TREES TO BE RETAINED OR WHERE SCARIFICATION WOULD DAMAGE TREE ROOTS. DO NOT COMPACT WITHIN TREE PROTECTION ZONES.
9. RECOMMENDED SEED MIX FOR HILLSIDES AND LOW-FOOT TRAFFIC AMENITY ZONES IS PT 702. FOR HIGHER FOOT-TRAFFIC AREAS, USE PT 755.

*Tricia Juhnke*

APPROVED BY: TRICIA JUHNKE  
CITY ENGINEER



STANDARD DETAIL NUMBER: **774** SCALE: **NOT TO SCALE**

**SOIL AMENDMENT AND DEPTH**

PUBLICATION DATE: 03/01/2020 REVISION DATE: 02/11/2020

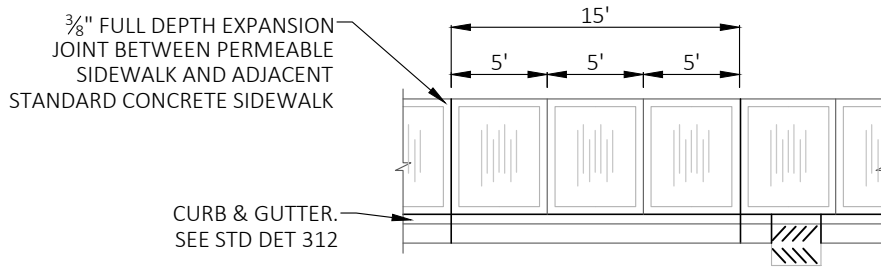

**PLAN VIEW - PERMEABLE SIDEWALK**

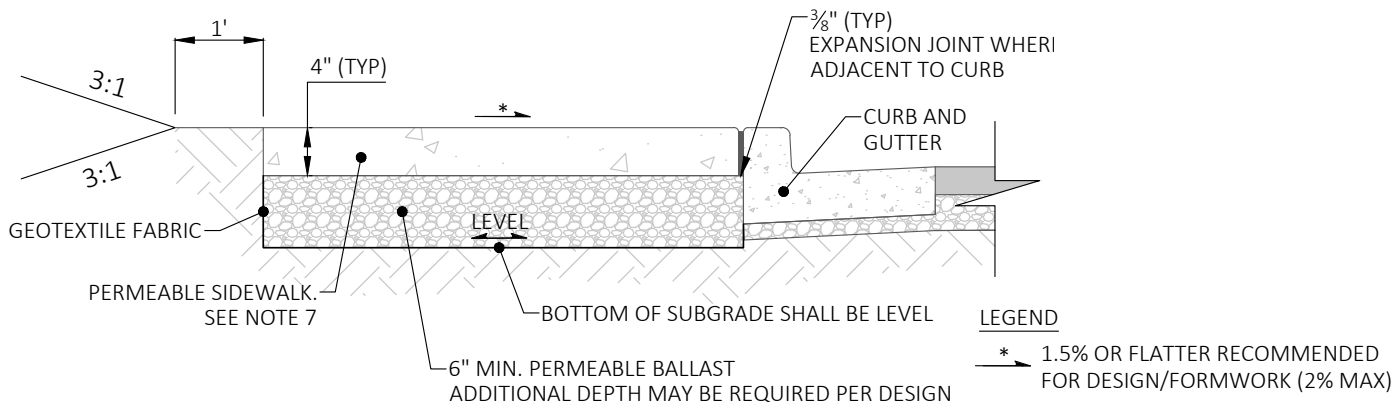

**PERMEABLE SIDEWALK SECTION**

**NOTES:**

1. REFER TO STD DETAIL 309 FOR JOINT REQUIREMENTS.
2. SIDEWALK SHALL BE ADA COMPLIANT.
3. PERVIOUS CONCRETE SHALL BE INSTALLED BY A CERTIFIED PERVIOUS CONCRETE INSTALLER (NRMCA OR EQUIVALENT).
4. LIDS FOR JUNCTION BOXES AND UTILITY VAULTS SHALL BE NON-SKID, FLUSH WITH THE SURFACE, AND MATCH THE GRADE OF THE SIDEWALK.
5. CONCRETE SHALL CONFORM TO ALL REQUIREMENTS OF ACI 522.1-13 SPECIFICATION FOR PERVIOUS CONCRETE PAVEMENT. CONCRETE MIX SHALL MEET THE FOLLOWING:
  - a. 100% PASSING 3/8" SIEVE
  - b. WATER/CM RATION BETWEEN 0.28-0.35
  - c. MINIMUM INFILTRATION RATE OF 100 INCHES/HOUR PER ASTM C1701
6. PERMEABLE SIDEWALK SHALL BE TESTED PRIOR TO ACCEPTANCE. ONE TEST PER 2500 SF AREA MINIMUM. TESTING SHALL MEET ASTM C1701 AND SHALL MEET A MINIMUM RATE OF 100 INCHES/HOUR.
7. REMOVAL/REPLACEMENT OF PERMEABLE SIDEWALK SHALL BE FROM EXPANSION JOINT TO EXPANSION JOINT UNLESS OTHERWISE DIRECTED BY THE CITY ENGINEER.
8. PERMEABLE SIDEWALK SHALL BE PROTECTED FROM RUNOFF AND SEDIMENT UNTIL THE SIDEWALK IS CURED AND ALL ADJACENT AREAS ARE PERMANENTLY STABILIZED. CONSTRUCTION VEHICULAR TRAFFIC SHALL NOT BE ALLOWED ONTO THE PERMEABLE SIDEWALK. ALL PERMEABLE SURFACES SHALL BE VACUUMED IMMEDIATELY AFTER SAWCUTTING TO PREVENT CLOGGING.
9. PERMEABLE BALLAST SHALL BE CLEAN, ANGULAR ROCK CONFORMING TO WSDOT STANDARD SPECIFICATION 9-03.9(2).
10. GEOTEXTILE SHALL BE NONWOVEN, MODERATE SURVIVABILITY PER WSDOT STANDARD SPECIFICATION 9-33.2(1).
11. CHECK DAMS ARE REQUIRED ON LONGITUDINAL SUBGRADE SLOPES OF GREATER THAN 2%. SEE STD DETAIL 776.
12. TO PREVENT COMPACTION, INSTALL THE AGGREGATE BASE IN THE FOLLOWING MANNER (BACK DUMPING): DUMP AGGREGATE BASE ONTO SUBGRADE FROM THE EDGE OF THE INSTALLATION, THEN PUSH IT OUT ONTO THE SUBGRADE. DUMP SUBSEQUENT LOADS FROM ON TOP OF THE AGGREGATE BASE AS THE INSTALLATION PROGRESSES.

*Tricia Juhnke*

APPROVED BY: TRICIA JUHNKE  
CITY ENGINEER



STANDARD DETAIL NUMBER: **775** SCALE: **NOT TO SCALE**

**PERMEABLE SIDEWALK**

PUBLICATION DATE: 03/01/2020 REVISION DATE: 02/11/2020

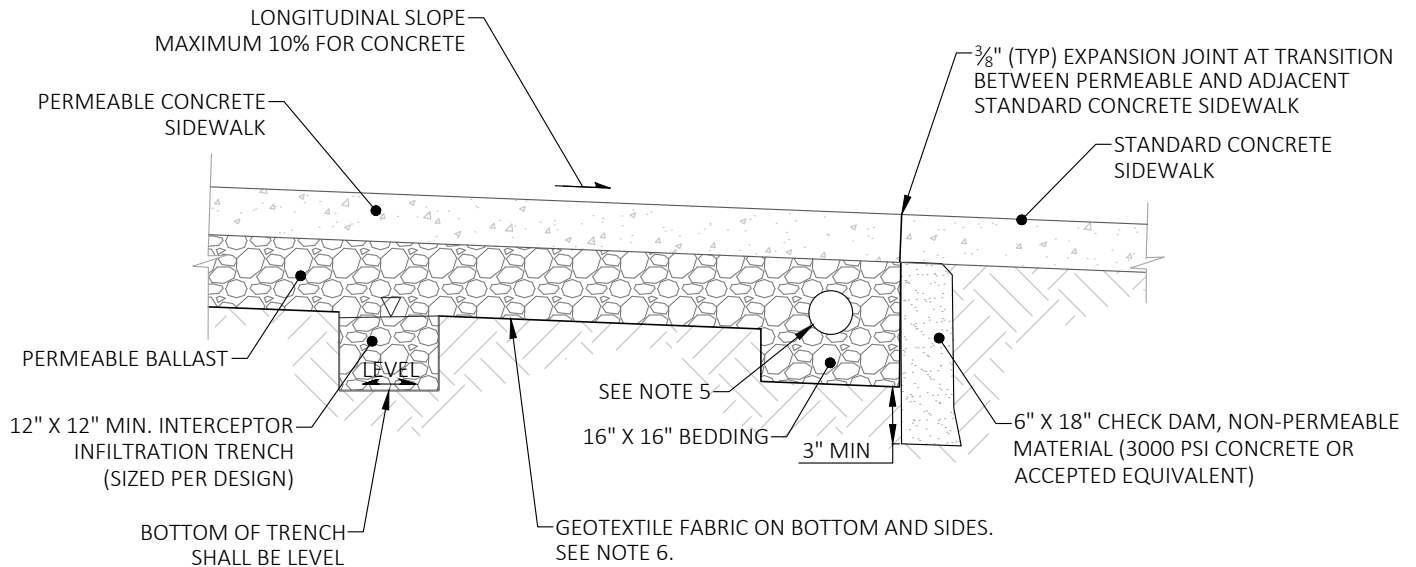

**PERMEABLE SIDEWALK INTERCEPTOR TRENCH**

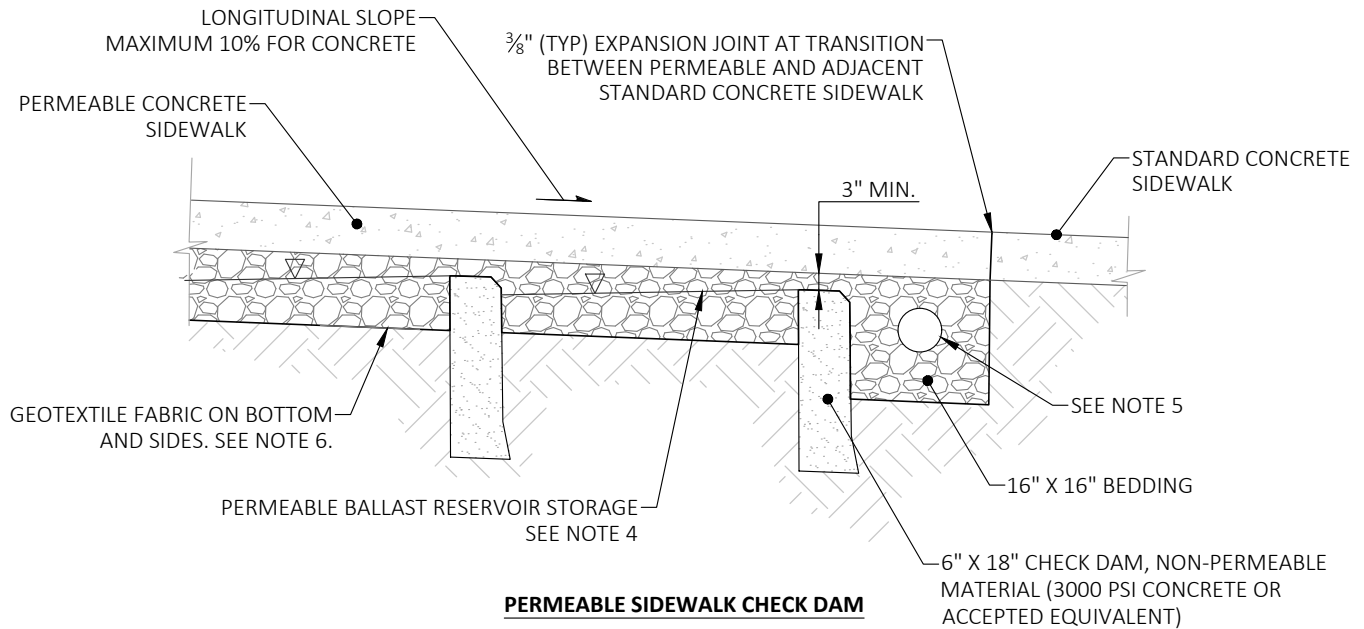

**PERMEABLE SIDEWALK CHECK DAM**

**NOTES:**

1. CHECK DAM OR INTERCEPTOR TRENCH REQUIRED FOR LONGITUDINAL SUBGRADE SLOPES >2%. TRANSVERSE SLOPE SHALL BE LEVEL.
2. SPACE CHECK DAMS BASED ON SLOPE TO ACHIEVE DESIGN AVERAGE PONDING DEPTH BEFORE OVERTOPPING DAM.
3. REFER TO STD DETAIL FOR PERMEABLE SIDEWALK AND RESERVOIR DETAILS.
4. THE STORAGE VOLUME BETWEEN CHECK DAMS SHALL BE BASED ON CHECK DAM HEIGHT AND SPACING FOR MODELING. CHECK DAM HEIGHT AND SUBGRADE SLOPE SHALL BE SPECIFIED ON THE PLANS.
5. 6" PVC PERFORATED PIPE WITH CLEANOUTS AND CONNECTION TO STORM.
6. GEOTEXTILE SHALL BE NONWOVEN, MODERATE SURVIVABILITY PER WSDOT STANDARD SPECIFICATION 9-33.2(1).
7. SIDEWALK SHALL BE ADA COMPLIANT.

*Tricia Juhnke*

APPROVED BY: TRICIA JUHNKE  
CITY ENGINEER



STANDARD DETAIL NUMBER: **776**

SCALE: **NOT TO SCALE**

**PERMEABLE SIDEWALK ON SLOPES**

PUBLICATION DATE: 03/01/2020 REVISION DATE: 02/11/2020

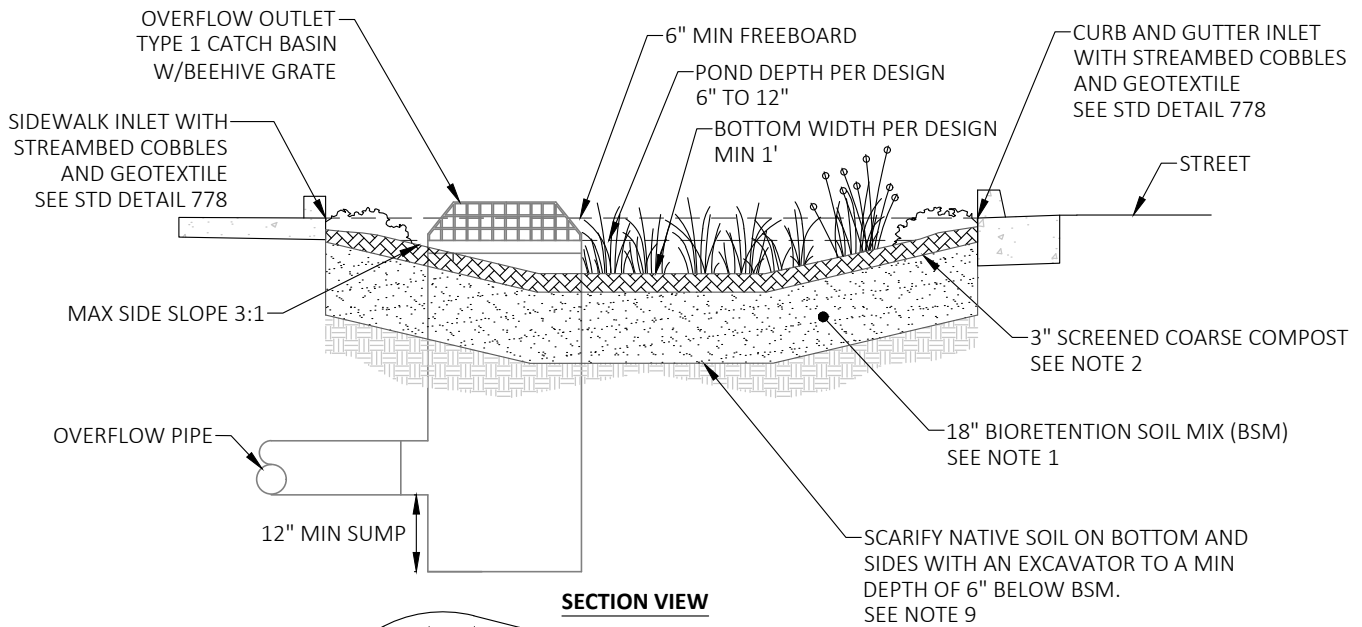

**SECTION VIEW**

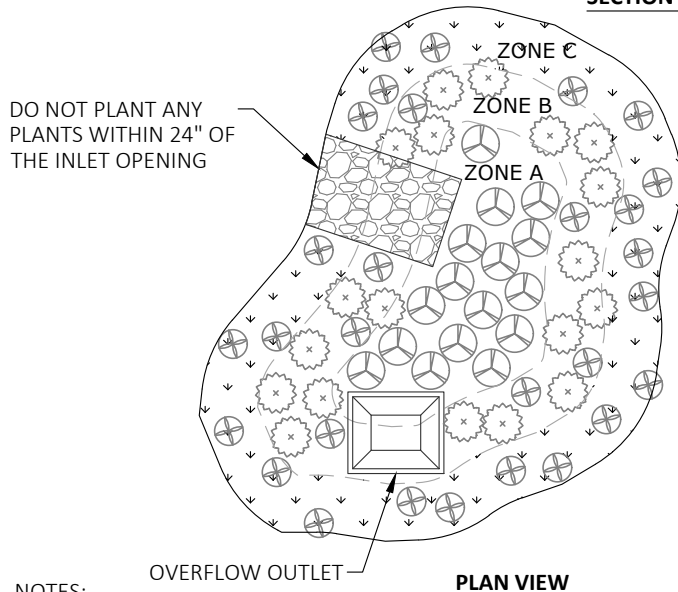

**PLAN VIEW**

**PLANTING ZONES:**

- ZONE A: BOTTOM OF FACILITY, AREA WITH FREQUENT STANDING WATER
- ZONE B: LOWER SIDE SLOPE, AREA WITH OCCASIONAL STANDING WATER AND EXTENDED DRIER PERIOD.
- ZONE C: UPPER SIDE SLOPE, DRIEST PORTION OF THE FACILITY.

**NOTES:**

1. REFER TO PLANS FOR BIORETENTION FACILITY SHAPE, PLANTINGS, ELEVATIONS, SURFACE AREA, INLET CONFIGURATION, AND ADDITIONAL DESIGN FEATURES.
2. BIORETENTION SOIL MIX (BSM) SHALL MEET WSDOT STANDARD SPEC. DO NOT COMPACT BSM.
3. COARSE COMPOST SHALL MEET WSDOT STD SPEC 9-14.5(8).
4. MAXIMUM BOTTOM SLOPE OF CELL IS 0.5%.
5. OVERFLOW POINT SHALL BE AT LEAST 6 INCHES BELOW ANY ADJACENT PAVEMENT AREA.
6. INSTALL 4" STREAMBED COBBLE AT INLET TO DISSIPATE RUNOFF. SEE STANDARD DETAIL 778.
7. MINIMUM 3 FOOT DEPTH BETWEEN BOTTOM OF BSM AND WATER TABLE.
8. MINIMUM SETBACK OF 5 FEET FROM TOP OF BIORETENTION CELL TO BUILDING STRUCTURES AND PROPERTY LINES. DO NOT LOCATE IMMEDIATELY UP SLOPE OF BUILDING STRUCTURES.
9. AVOID COMPACTION OF NATIVE SOIL BELOW FACILITY DURING CONSTRUCTION. DO NOT OPERATE HEAVY EQUIPMENT WITHIN THE FACILITY FOOTPRINT. DO NOT PLACE OR AMEND BSM WHEN THE GROUND IS FROZEN OR WHEN THE SOIL IS EXCESSIVELY WET.
10. FOR FACILITIES IN THE RIGHT-OF-WAY, REFER TO EDM APPENDIX K FOR APPROVED PLANTS IN EACH ZONE.

*Tricia Juhnke*

APPROVED BY: TRICIA JUHNKE  
CITY ENGINEER



STANDARD DETAIL NUMBER: **777** SCALE: **NOT TO SCALE**

**BIORETENTION FACILITY**

PUBLICATION DATE: 03/01/2020 REVISION DATE: 02/11/2020



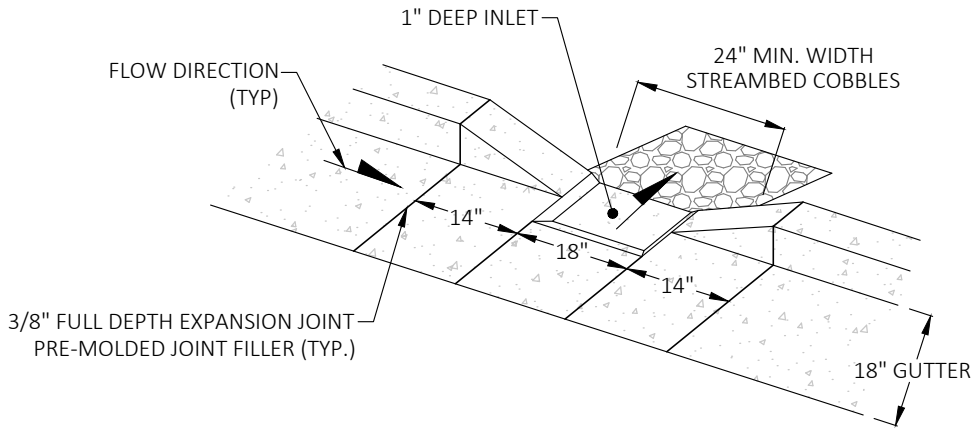

**CURB AND GUTTER INLET**

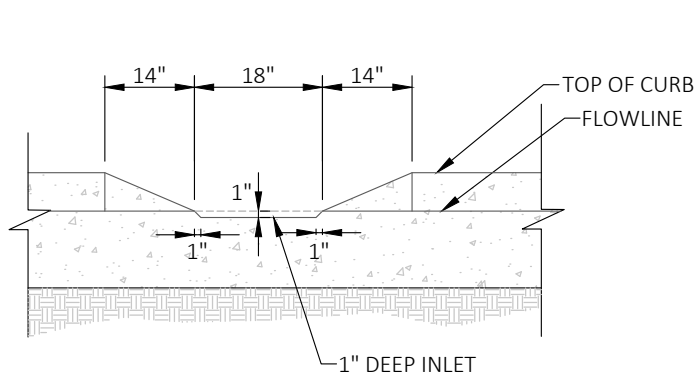

**FLOWLINE VIEW - CURB AND GUTTER INLET**

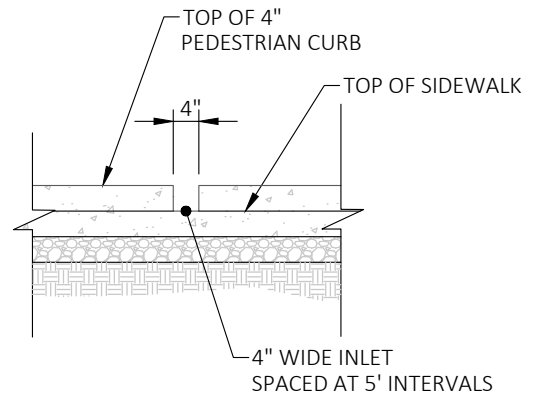

**FLOWLINE VIEW - SIDEWALK INLET**

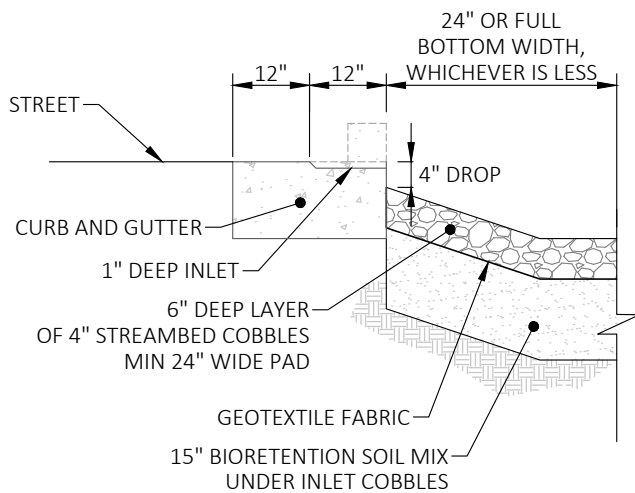

**SECTION VIEW - CURB AND GUTTER INLET**

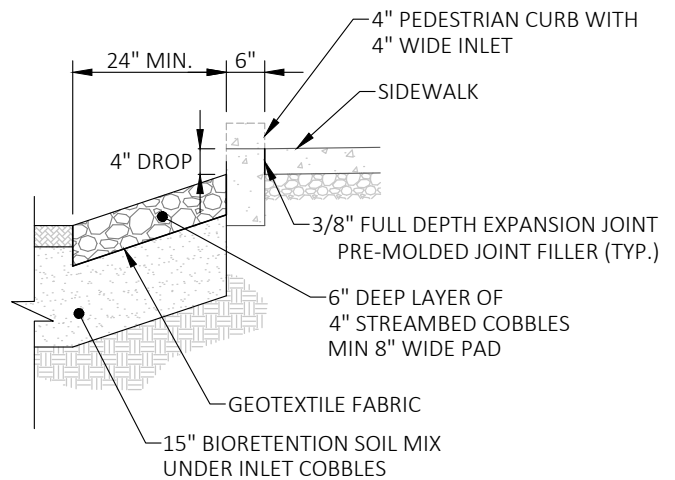

**SECTION VIEW - SIDEWALK INLET**

**NOTES:**

1. REFER TO STD DETAIL 777 FOR BIORETENTION FACILITY DETAILS.
2. PROVIDE 4" MIN DROP FROM GUTTER OR SIDEWALK ELEVATION.
3. GEOTEXTILE SHALL BE NONWOVEN, MODERATE SURVIVABILITY PER WSDOT STANDARD SPECIFICATION 9-33.2(1).

*Tricia Juhnke*

APPROVED BY: TRICIA JUHNKE  
CITY ENGINEER



STANDARD DETAIL NUMBER: **778** SCALE: **NOT TO SCALE**

**BIORETENTION INLET**

PUBLICATION DATE: 03/01/2020 REVISION DATE: 02/11/2020