



HIDDEN LAKE CULVERT REPLACEMENT

Bid Number: **xx**

Date: March 2019

17500 Midvale Avenue North
Shoreline, WA 98133
(206) 801-2700

SHORELINE CITY COUNCIL

WILL HALL
MAYOR

DORIS MCCONNELL
DEPUTY MAYOR

SUSAN CHANG
KEITH MCGLASHAN
CHRIS ROBERTS
BETSY ROBERTSON
KEITH SCULLY

DIRECTOR OF PUBLIC WORKS
RANDY WITT, PE

PROJECT MANAGER
JOHN FEATHERSTONE, PE

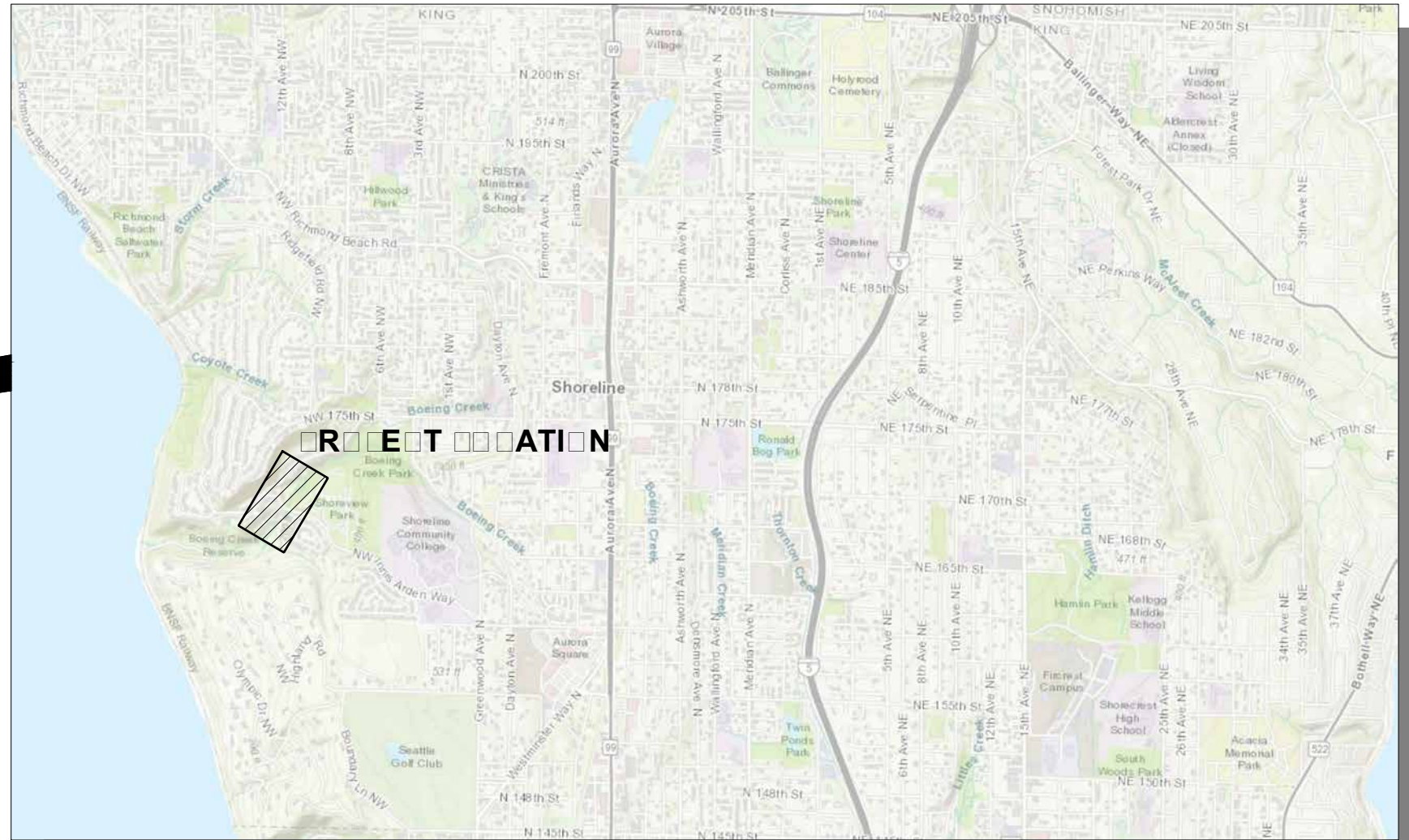

VICINITY MAP

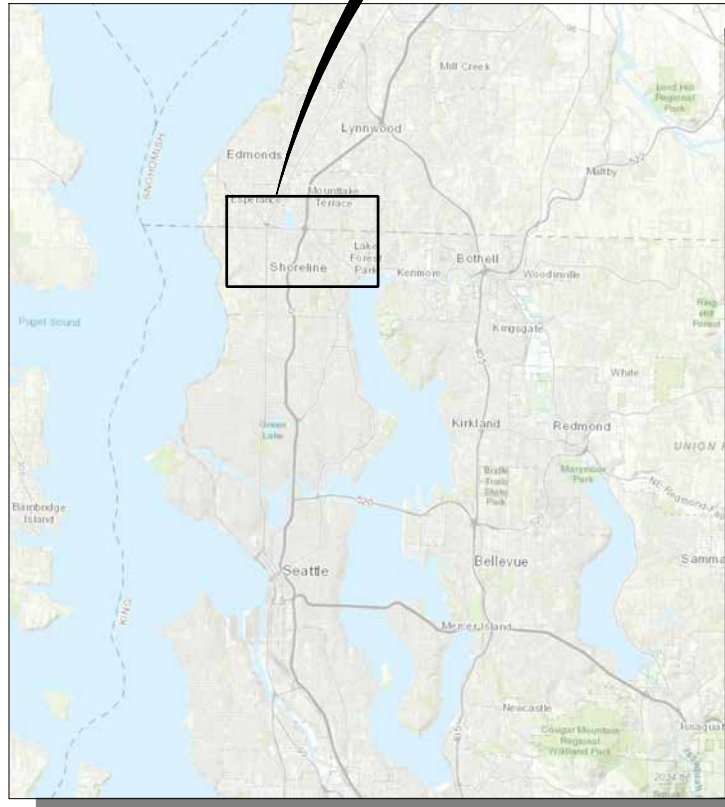

LOCATION MAP



INDEX OF SHEETS		
SHEET NO.	DRAWING NO.	SHEET TITLE
1	G-1.0	COVER SHEET AND SHEET INDEX
2	G-1.1	ABBREVIATIONS AND LEGEND
3	G-1.2	GENERAL NOTES
4	G-2.0	EXISTING SITE PLAN
5	C-1.0	PROPOSED SITE PLAN
6	C-2.0	SITE PREPARATION PLAN AND TESC PLAN
7	C-2.1	STREAMFLOW BYPASS PLAN AND CONSTRUCTION SEQUENCING
8	C-3.0	UTILITY PROTECTION AND RELOCATION PLAN
9	C-3.1	PROPOSED UTILITY RELOCATION
10	C-4.0	CULVERT REPLACEMENT PLAN AND PROFILE
11	C-4.1	CULVERT REPLACEMENT SECTIONS
12	C-4.2	BANK AND COIR DETAILS
13	L-1.0	PLANTING PLAN
14	S-1	CULVERT LAYOUT
15	S-2	TYPICAL SECTION
16	S-3	CULVERT CONSTRUCTION SEQUENCE
17	S-4	WEST RETAINING WALL PLAN AND PROFILE
18	S-5	EAST RETAINING WALL PLAN AND PROFILE

ENGINEER:

HERRERA ENVIRONMENTAL CONSULTANTS
2200 SIXTH AVENUE
SUITE 1100
SEATTLE, WA 98121
PHONE: (206) 441-9080
CONTACT: IAN MOSTRENKO, PE

HORIZ: NAD 83 WA NORTH
VERT: NAVD 88

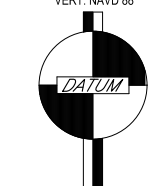

APPROVED FOR CONSTRUCTION

TRICIA JUHNKE, P.E., CITY ENGINEER
DATE

**NOT DESIGN NOT FOR CONSTRUCTION
NOTED IN PART BY A REVISION RANT
FROM THE COUNTY OF DISTRICT**



**HIDDEN LAKE CULVERT
REPLACEMENT
30 PCT DESIGN - NOT FOR
CONSTRUCTION
COVER SHEET AND SHEET INDEX**



Know what's below.
Call before you dig.

ONE INCH AT FULL SIZE

IF NOT ONE INCH SCALE ACCORDINGLY

Project No. 18-06771-000

Sheet

G-1.0

Sheet 1 Of 18

Mar 20, 2019 - 3:59pm emarshall C:\proj\Y2018\18-06771-000\CAD\DWG\Culvert\G-1.1.dwg

ABBREVIATIONS

APPROX	APPROXIMATE
AVE	AVENUE
AVG	AVERAGE
BLDG	BUILDING
BMP	BEST MANAGEMENT PRACTICE
CB	CATCH BASIN
C/L	CENTERLINE
COMM	COMMUNICATION
CONC	CONCRETE
CONST	CONSTRUCT, CONSTRUCTION
CP	CONTROL POINT
CSBC	CRUSHED SURFACING BASE COURSE
CSTC	CRUSHED SURFACING TOP COURSE
DIA	DIAMETER
DR	DRIVE
DWG	DRAWING
E	EAST, EASTING
EA	EACH
EL, ELEV	ELEVATION
ELJ	ENGINEERED LOG JAM
EX, EXIST	EXISTING
FT	FEET/FOOT
HOR	HORIZONTAL
HT	HEIGHT
IE	INVERT ELEVATION
IN	INCH/INCHES
LF	LINEAL FOOT/FEET
MAX	MAXIMUM
MIN	MINIMUM
N	NORTH/NORTHING
NA	NOT APPLICABLE
NO	NUMBER
NTS	NOT TO SCALE
OC	ON CENTER
OHW	ORDINARY HIGH WATER
QTY	QUANTITY
ROW	RIGHT-OF-WAY
S	SOUTH, SLOPE
SD	STORM DRAIN
ST	STORM SEWER
STA	STATION
STD	STANDARD
TESC	TEMPORARY EROSION AND SEDIMENT CONTROL
TYP	TYPICAL
W	WEST, WATER
WSDOT	WASHINGTON STATE DEPARTMENT OF TRANSPORTATION
WSE	WATER SURFACE ELEVATION

LEGEND EXISTING FEATURES

	PARCEL LINE
	EASEMENT
	RIGHT-OF-WAY
	POND
	ORDINARY HIGH WATER
	DITCH
	WETLAND
	FENCE
	EDGE OF PAVEMENT
	GUARDRAIL
	SANITARY SEWER
	GAS LINE
	WATER LINE
	TELEPHONE LINE
	SANITARY SEWER MANHOLE
	WATER VALVE
	CONIFEROUS TREE
	DECIDUOUS TREE
	TRAIL

LEGEND PROPOSED FEATURES

	PROJECT LIMITS
	CLEAR AND GRUB LIMITS
	DESIGN CONTOURS
	HI-VISIBILITY FENCE
	HIGH VISIBILITY SILT FENCE
	WEED MANAGEMENT AREA
	ACCESS ROAD
	REMOVE ITEM
	ABANDON ITEM
	BYPASS PIPE
	CONSTRUCTION STAGING AREA
	STABILIZED CONSTRUCTION ENTRANCE
	BYPASS PUMP
	CONTROL POINT
	REMOVE CONIFEROUS TREE
	REMOVE DECIDUOUS TREE

TOWNSHORELINE STANDARD PLAN NOTES

GENERAL NOTES

1. THE CONTRACTOR SHALL ADHERE TO ALL APPLICABLE NOTES UNLESS OTHERWISE DIRECTED BY THESE PLANS, THE ENGINEER OR A CITY OF SHORELINE REPRESENTATIVE.
2. THE CONTRACTOR SHALL VERIFY ALL EXISTING DATA SHOWN IN THESE DOCUMENTS AND NOTIFY ENGINEER IMMEDIATELY OF ANY CONFLICTS WITH PROPOSED FEATURES PRIOR TO CONSTRUCTION. SEE DWG G-2.0 FOR SURVEY CONTROL.
3. ALL COMPACTION METHODS, MATERIALS AND PERFORMANCE CRITERIA SHALL BE IN ACCORDANCE WITH THE PROJECT PLANS AND SPECIFICATIONS.
4. ALL EXISTING AND PROPOSED CATCH BASINS DOWNSTREAM OF DISTURBED AREA SHALL BE PROTECTED DURING CONSTRUCTION PER THE WSDOT STD PLAN 1-40.20-00.
5. STORM DRAINAGE (SD) PIPE SHALL BE CORRUGATED POLYETHYLENE PIPE WITH SMOOTH INTERIOR WALLS UNLESS NOTED OTHERWISE.
6. ALL PIPE LENGTHS, INVERT ELEVATIONS AND DRAINAGE STRUCTURE LOCATIONS ARE MEASURED AT THE CENTER OF THE DRAINAGE STRUCTURE UNLESS NOTED OTHERWISE.
7. ALL LOCATIONS OF EXISTING UTILITIES SHOWN HAVE BEEN ESTABLISHED BY FIELD SURVEY OR OBTAINED FROM AVAILABLE RECORDS AND SHOULD THEREFORE BE CONSIDERED APPROXIMATE ONLY AND NOT NECESSARILY COMPLETE. IT IS THE SOLE RESPONSIBILITY OF THE CONTRACTOR TO VERIFY THE ACCURACY OF ALL UTILITY LOCATIONS SHOWN AND AVOID OTHER UTILITIES NOT SHOWN ON THE PLANS. EXISTING UTILITIES SHALL BE PROTECTED, SUPPORTED, OR MAINTAINED DURING CONSTRUCTION.
8. CONTACT THE UNDERGROUND UTILITIES LOCATION SERVICE (1-800-424-5555) AT LEAST 48 HOURS PRIOR TO CONSTRUCTION.
9. SEE THE PROJECT SPECIFICATIONS FOR ADDITIONAL INFORMATION.

NOTE SN

- SN.1. THE CONTRACTOR SHALL HAVE ANY REQUIRED PERMIT(S) AND CONDITIONS AND THE APPROVED PLANS AVAILABLE AT THE JOB SITE.
- SN.2. ALL WORK SHALL CONFORM TO THESE APPROVED PLANS AND SPECIFICATIONS, THE SHORELINE MUNICIPAL CODE, THE ENGINEERING DEVELOPMENT MANUAL, AND FEDERAL AND STATE REQUIREMENTS.
- SN.3. ALL INSTALLATION METHODS AND MATERIALS SHALL MEET THE WSDOT/APWA STANDARD SPECIFICATIONS.
- SN.4. ANY CHANGES FROM THE APPROVED PLANS REQUIRE PRE-APPROVAL FROM THE ENGINEER.
- SN.5. SEE SPECIFICATIONS SECTION 1-08.0(2) FOR HOURS OF WORK.
- SN.6. LOCATIONS FOR EXISTING UTILITIES ARE APPROXIMATE.
- SN.7. THE CONTRACTOR ASSUMES SOLE RESPONSIBILITY FOR WORKER SAFETY AND DAMAGE FROM CONSTRUCTION OPERATIONS TO STRUCTURES AND OTHER IMPROVEMENTS.
- SN.8. SURVEYING FOR PUBLIC FACILITIES SHALL BE PERFORMED UNDER THE DIRECTION OF A WASHINGTON LICENSED LAND SURVEYOR. VERTICAL DATUM SHALL BE NAVD 1988. HORIZONTAL DATUM SHALL BE WASHINGTON STATE (GRID) COORDINATES, NORTH ZONE, USING NAD 83/91 SURVEY CONTROL AND TO ANY TWO CITY OF SHORELINE HORIZONTAL CONTROL MONUMENTS. FOR PROJECTS WITHIN A FLOOD CONTROL ZONE, THE SURVEYOR SHALL PROVIDE CONVERSION CALCULATIONS TO NGVD 1929.
- SN.9. REPLACE OR RELOCATE ALL SIGNS, STRIPING, POLES AND OTHER ITEMS IN THE RIGHT-OF-WAY THAT ARE DAMAGED OR REMOVED DURING CONSTRUCTION.
- SN.10. RETAIN, REPLACE OR RESTORE ALL VEGETATION IN RIGHTS-OF-WAY, EASEMENTS, AND ACCESS TRACTS DISTURBED DURING CONSTRUCTION.
- SN.11. INTERRUPTION OF NORMAL TRAFFIC FLOW SHALL REQUIRE TRAFFIC CONTROL. REFER TO THE MANUAL OF UNIFORM TRAFFIC CONTROL DEVICES (MUTCD) AND WSDOT STANDARD SPECIFICATIONS. TRAFFIC CONTROL IS REQUIRED FOR ALL TRANSVERSE CUTS IN ROADWAY. FOR INFORMATION CONTACT THE CITY OF SHORELINE RIGHT-OF-WAY INSPECTOR.
- SN.12. THE CONTRACTOR SHALL BE RESPONSIBLE FOR PROVIDING ADEQUATE SAFEGUARDS, SAFETY DEVICES, PROTECTIVE EQUIPMENT, FLAGGERS, AND ANY OTHER NEEDED ACTIONS TO PROTECT THE LIFE, HEALTH, AND SAFETY OF THE PUBLIC, AND TO PROTECT PROPERTY IN CONNECTION WITH THE PERFORMANCE OF WORK COVERED BY THE CONTRACTOR. ANY WORK WITHIN THE TRAVELED RIGHT-OF-WAY REQUIRES A RIGHT-OF-WAY USE PERMIT, TO BE REVIEWED PRIOR TO CONSTRUCTION AND INSPECTED DURING CONSTRUCTION.
- SN.13. THE CONTRACTOR SHALL RESTORE TO CURRENT STANDARDS CRITICAL AREAS, AND PUBLIC AND PRIVATE PROPERTY DAMAGED BY CONTRACTOR'S OPERATIONS.
- SN.14. AT ALL TIMES MAINTAIN ACCESS TO BUILDINGS FOR FIRE, PEDESTRIAN AND VEHICULAR ACCESS.
- SN.15. BEFORE BEGINNING ANY CONSTRUCTION ACTIVITIES, ESTABLISH CLEARING LIMITS, INSTALL CONSTRUCTION ENTRANCE, AND INSTALL BEST MANAGEMENT PRACTICES.
- SN.16. ALL UTILITY TRENCHES AND ROADWAY SUBGRADES WITHIN CITY RIGHT-OF-WAY SHALL BE BACKFILLED AND COMPACTED IN ACCORDANCE WITH KING COUNTY ROAD STANDARDS. 100% CRUSHED ROCK OR CONTROLLED DENSITY FILL (CDF)

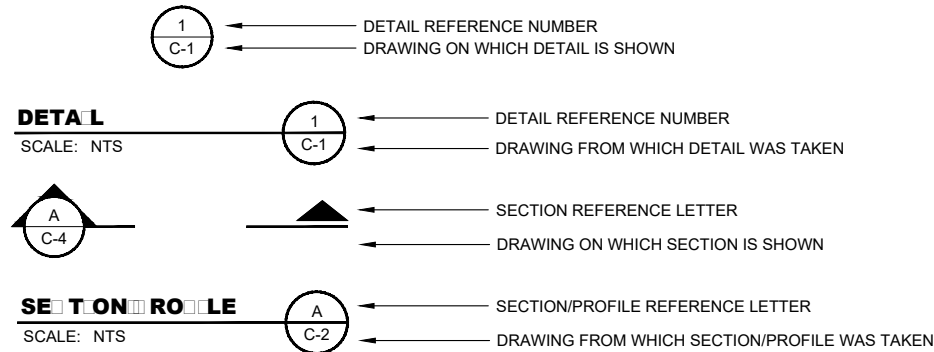

"1" INDICATES THAT THE DETAIL/SECTION IS SHOWN ON THE SAME SHEET
 "TYP" INDICATES THAT THE DETAIL/SECTION IS UNIFORMLY TYPICAL THROUGHOUT PROJECT EXCEPT WHERE OTHERWISE NOTED
 "VAR" SPECIFIES THAT DETAIL/SECTION WAS TAKEN FROM VARIOUS DRAWINGS

NOTE AND DETAIL SECTION REFERENCE

Description		Date		Initials	
				EM	IBM, VV
				Drawn	Designed
				Checked	Revisions
				Revisions	Revisions

17500 Midvale Avenue North
Shoreline, WA 98133
(206) 801-2700

HIDDEN LAKE CULVERT REPLACEMENT

30 PCT DESIGN - NOT FOR CONSTRUCTION

ABBREVIATIONS AND LEGEND

Know what's below. Call before you dig.
ONE INCH AT FULL SIZE
IF NOT ONE INCH SCALE ACCORDINGLY

Project No. 18-06771-000

Sheet G-1.1

Sheet 2 Of 18



C:\p\proj\2018\18-06771-000\CAD\DWG\Culvert[G-1.2.dwg] emarshall Mar 20, 2019 - 3:59pm

EROSION AND SEDIMENTATION CONTROL REQUIREMENTS TESC

TESC.1. THE IMPLEMENTATION AND MAINTENANCE OF EROSION CONTROL FACILITIES IS THE RESPONSIBILITY OF THE CONTRACTOR ON A DAILY BASIS AND UNTIL ALL CONSTRUCTION IS APPROVED.

TESC.2. AT ALL TIMES PROTECT CRITICAL AREAS AND THEIR BUFFERS, ADJACENT PRIVATE PROPERTIES AND PUBLIC PROPERTY AND SURVEY MONUMENTS.

TESC.3. EROSION AND SEDIMENTATION CONTROL (ESC) FACILITIES MUST BE CONSTRUCTED PRIOR TO AND IN CONJUNCTION WITH ALL CLEARING AND GRADING ACTIVITIES, AND IN SUCH A MANNER AS TO ENSURE THAT SEDIMENT-LADEN WATER OR AIRBORNE SEDIMENT DOES NOT ENTER THE DRAINAGE SYSTEM OR VIOLATE APPLICABLE WATER OR AIR QUALITY STANDARDS DURING THE CONSTRUCTION PERIOD. THESE ESC FACILITIES SHALL BE UPGRADED TO INCLUDE ADDITIONAL SUMPS, DITCHES, FENCES, ETC. AS NEEDED FOR UNEXPECTED STORM EVENTS.

TESC.4 STABILIZED CONSTRUCTION ENTRANCE AND WASH PAD SHALL BE INSTALLED AT THE BEGINNING OF CONSTRUCTION AND MAINTAINED FOR THE DURATION OF THE PROJECT. ADDITIONAL MEASURES MAY BE REQUIRED BY THE CITY OF SHORELINE TO ENSURE THAT PAVED AREAS ARE KEPT CLEAN FOR THE PROJECT DURATION.

TESC.5. ANY AREA STRIPPED OF VEGETATION (INCLUDING ROADWAY EMBANKMENTS), WHERE NO FURTHER WORK IS ANTICIPATED FOR A PERIOD OF 2 DAYS, SHALL BE IMMEDIATELY STABILIZED WITH APPROVED ESC METHODS AS FOLLOWS.

FROM MAY 1 THROUGH SEPTEMBER 30, INSTALL TESC COVER MEASURES TO PROTECT DISTURBED AREAS THAT WILL REMAIN UNWORKED FOR SEVEN DAYS OR MORE.

FROM OCTOBER 1 THROUGH APRIL 30:
 A. INSTALL TESC COVER MEASURES TO PROTECT DISTURBED AREAS THAT WILL REMAIN UNWORKED FOR TWO DAYS OR MORE.
 B. PROTECT STOCKPILES AND STEEP CUT/FILL SLOPES IF UNWORKED FOR MORE THAN 12 HOURS
 C. STOCKPILE ON SITE ENOUGH COVER MATERIALS TO COVER ALL DISTURBED AREAS.

ANY AREA NEEDING ESC MEASURES, NOT REQUIRING IMMEDIATE ATTENTION, SHALL BE ADDRESSED WITHIN 15 DAYS.

TESC.6. ESC FACILITIES ON INACTIVE SITES SHALL BE INSPECTED AND MAINTAINED A MINIMUM OF ONCE A MONTH OR WITHIN 48 HOURS FOLLOWING A STORM EVENT.

TESC.7. BY OCTOBER 8, SEED ALL AREAS THAT WILL REMAIN UNWORKED FROM OCTOBER 1 THROUGH APRIL 30. MULCH ALL SEEDED AREAS.

TESC.8. AT NO TIME SHALL MORE THEN ONE (1) FOOT OF SEDIMENT BE ALLOWED TO ACCUMULATE WITHIN A CATCH BASIN. ALL CATCH BASINS & CONVEYANCE LINES SHALL BE CLEANED PRIOR TO PAVING. THE CLEANING OPERATION SHALL NOT FLUSH SEDIMENT-LADEN WATER INTO A DOWNSTREAM SYSTEM.

TESC.9. WHERE SEEDING FOR TEMPORARY EROSION CONTROL IS REQUIRED, FAST-GERMINATING GRASSES SHALL BE APPLIED AT AN APPROPRIATE RATE (E.G. ANNUAL OR PERENNIAL RYE APPLIED AT APPROXIMATELY 80 POUNDS PER ACRE). WHERE STRAW MULCH FOR TEMPORARY EROSION CONTROL IS REQUIRED, IT SHALL BE APPLIED AT A MINIMUM THICKNESS OF TWO INCHES.

TESC.10. FILTER FABRIC FENCING SHALL BE PURCHASED IN A CONTINUOUS ROLL AND CUT TO THE LENGTH OF THE BARRIER TO AVOID USE OF JOINTS. WHEN JOINTS ARE NECESSARY, FILTER CLOTH SHALL BE SPLICED TOGETHER ONLY AT A SUPPORT POST WITH A MINIMUM 24 INCHES OVERLAP AND BOTH ENDS SECURELY FASTENED TO THE POST.

TESC.11. THE FILTER FABRIC FENCE SHALL BE INSTALLED TO FOLLOW THE CONTOURS WHERE FEASIBLE. THE FENCE POSTS SHALL BE SPACED A MAXIMUM OF SIX FEET APART AND DRIVEN SECURELY INTO THE GROUND A MINIMUM OF 30 INCHES. A TRENCH SHALL BE EXCAVATED UPGRADIENT AND ADJACENT TO THE WOOD POST TO ALLOW THE FILTER FABRIC TO BE BURIED.

TESC.12. WHEN STANDARD STRENGTH FILTER FABRIC IS USED, A WIRE MESH SUPPORT FENCE SHALL BE FASTENED SECURELY TO THE UPGRADIENT SIDE OF THE POSTS USING HEAVY DUTY WIRE STAPLES, TIE WIRES, OR HOG RINGS. THE WIRE SHALL EXTEND INTO THE TRENCH A MINIMUM OF FOUR INCHES. THE STANDARD STRENGTH FILTER FABRIC SHALL NOT BE STAPLED TO EXISTING TREES.

TESC.13. WHEN EXTRA-STRENGTH FILTER FABRIC AND CLOSER POST SPACING ARE USED, THE WIRE MESH SUPPORT FENCE MAY BE ELIMINATED. IN SUCH A CASE, THE FILTER FABRIC IS STAPLED OR WIRED DIRECTLY TO THE POSTS WITH ALL OTHER PROVISIONS OF STANDARD NOTES APPLY. FILTER FABRIC FENCES SHALL BE REMOVED WHEN THEY HAVE SERVED THEIR USEFUL PURPOSE, BUT NOT BEFORE THE UPGRADIENT SLOPE AREA HAS BEEN PERMANENTLY STABILIZED. FILTER FABRIC FENCES SHALL BE INSPECTED IMMEDIATELY AFTER EACH RAINFALL AND AT LEAST DAILY DURING PROLONGED RAINFALL. ANY REQUIRED REPAIRS SHALL BE MADE IMMEDIATELY.

TESC.14. THE EROSION PREVENTION AND SEDIMENT CONTROL BEST MANAGEMENT PRACTICES SHOWN ON THESE PLANS ARE MINIMUM REQUIREMENTS. FIELD ADJUSTMENTS SHALL BE MADE TO ENSURE THE TESC PERFORMS IN ACCORDANCE WITH THE 2019 DEPARTMENT OF ECOLOGY STORMWATER MANAGEMENT MANUAL FOR WESTERN WASHINGTON, VOLUME II.

TESC.15. BEFORE ANY GROUND DISTURBANCE OCCURS ALL DOWNSTREAM BEST MANAGEMENT PRACTICES MUST BE CONSTRUCTED AND OPERATIONAL.

TESC.16. BEST MANAGEMENT PRACTICES SHALL REMAIN IN PLACE UNTIL FINAL SITE CONSTRUCTION IS COMPLETED AND PERMANENT STABILIZATION IS ESTABLISHED AND APPROVED BY THE CITY.

TESC.17. INSPECT AND MAINTAIN BEST MANAGEMENT PRACTICES DAILY IN ACCORDANCE WITH THE 2019 DEPARTMENT OF ECOLOGY STORMWATER MANAGEMENT MANUAL FOR WESTERN WASHINGTON, VOLUME II.

TESC.18. FAILURE TO MAINTAIN TESC MEASURES IN ACCORDANCE WITH ADOPTED STANDARDS MAY RESULT IN THE WORK BEING PERFORMED AT THE CITY'S DIRECTION AND THE COSTS DEDUCTED FROM MONIES OWED TO CONTRACTOR.

TESC.19. DURING THE LIFE OF THE PROJECT, THE CONTRACTOR SHALL MAINTAIN IN GOOD CONDITION AND PROMPTLY REPAIR, RESTORE OR REPLACE ALL GRADE SURFACES: WALLS, DRAINS, STRUCTURES, VEGETATION, TESC MEASURES, AND OTHER PROTECTIVE DEVICES IN ACCORDANCE WITH APPROVED PLANS.

TESC.20. THE CONTRACTOR SHALL MONITOR DOWNSTREAM DRAINAGE FEATURES, AND, WITH THE CITY'S APPROVAL, SHALL REMOVE ALL SEDIMENT DEPOSITION RESULTING FROM THE PROJECT-RELATED WORK.

TESC.21. ALL WORK SHALL BE PERFORMED PER APPROVED PLANS AND SPECIFICATIONS. THE CONTRACTOR SHALL MAINTAIN A SET OF APPROVED PLANS AND SPECIFICATIONS AND ASSOCIATED PERMITS ONSITE.

TESC.22. ALL WORK SHALL BE PERFORMED IN ACCORDANCE WITH ALL FEDERAL, STATE, AND LOCAL LAWS.

TESC.23. BEFORE REMOVING ANY TEMPORARY MEASURES, INSTALL AND ESTABLISH THE UPSTREAM PERMANENT MEASURES.

TRAFFIC CONTROL CONDITIONS TR

TC.1. INTERIM TRAFFIC CONTROL: THE DEVELOPER/CONTRACTOR SHALL BE RESPONSIBLE FOR INTERIM TRAFFIC CONTROL DURING CONSTRUCTION ON OR ALONG TRAVELED CITY ROADS.

TC.2. WHEN ROAD OR DRAINAGE WORK IS TO BE PERFORMED ON CITY ROADS THAT ARE OPEN TO TRAFFIC, THE CONTRACTOR WILL BE REQUIRED TO SUBMIT A WRITTEN TRAFFIC CONTROL PLAN FOR APPROVAL BY THE REVIEWING AGENCY 10 DAYS PRIOR TO BEGINNING THE WORK. TRAFFIC CONTROL SHALL FOLLOW THE GUIDELINES OF SECTION 1-07.23 OF THE WSDOT/APWA STANDARD SPECIFICATIONS.

TC.3. ALL BARRICADES, SIGNS AND FLAGGING SHALL CONFORM TO THE REQUIREMENTS OF THE MUTCD. SIGNS MUST BE LEGIBLE AND VISIBLE AND SHALL BE REMOVED AT THE END OF EACH WORK DAY IF NOT APPLICABLE AFTER CONSTRUCTION HOURS.

TC.4. TEMPORARY ROAD CLOSURES AND DETOURS: WHEN TEMPORARY ROAD CLOSURES CANNOT BE AVOIDED THE CONTRACTOR SHALL POST "TO BE CLOSED" SIGNS A MINIMUM OF FIVE DAYS PRIOR TO THE CLOSING. THE TYPES AND LOCATIONS OF THE SIGNS SHALL BE SHOWN ON A DETOUR PLAN.

TC.5. A DETOUR PLAN MUST BE PREPARED AND SUBMITTED TO THE CITY OF SHORELINE PUBLIC WORKS TRAFFIC SERVICES AT LEAST 10 WORKING DAYS IN ADVANCE, AND APPROVED PRIOR TO CLOSING ANY CITY ROAD. IN ADDITION, THE CONTRACTOR MUST NOTIFY, IN WRITING, LOCAL FIRE, SCHOOL, LAW ENFORCEMENT AUTHORITIES, METRO TRANSIT, AND ANY OTHER AFFECTED PERSONS AS DIRECTED BY THE ENGINEER AT LEAST FIVE DAYS PRIOR TO CLOSING.

TC.6. HAUL ROUTES: APPROVED HAUL ROUTES ARE NOTED ON THE PLANS. DEVIATIONS FROM THE DESIGNATED HAUL ROUTE SHALL BE SUBMITTED TO THE ENGINEER FOR APPROVAL.

TC.7. WHEN REQUIRED, THE HAUL ROUTE PLAN MUST BE PREPARED AND SUBMITTED TO THE REVIEWING AGENCY AND APPROVED PRIOR TO BEGINNING CONSTRUCTION. THE HAUL ROUTE PLAN SHALL ADDRESS ROUTING, HOURS OF OPERATION, SIGNAGE AND FLAGGING, AND DAILY MAINTENANCE.

TC.8. IF THE CONTRACTOR'S TRAFFIC FAILS TO USE THE DESIGNATED HAUL ROUTE, THE REVIEWING AGENCY MAY PROHIBIT OR LIMIT FURTHER WORK ON THE DEVELOPMENT UNTIL SUCH TIME AS THE REQUIREMENTS OF THE HAUL ROUTE ARE COMPLIED WITH.

TC.9. TRAFFIC CONTROL SHALL BE MAINTAINED BY THE CONTRACTOR FOR THE DURATION OF CONSTRUCTION. INTERRUPTION OF NORMAL TRAFFIC FLOW SHALL REQUIRE TRAFFIC CONTROL (SEE #SN.12, FOR DETAILS).

TC.10. CONTRACTOR SHALL PROTECT EXISTING TRAFFIC CONTROL SIGNS WITHIN THE LIMITS OF WORK

TREE PROTECTION TONS TR

PRE SITE WORKS

TP.1. BEFORE ANY CLEARING OR GRADING OCCURS INSTALL PROTECTION FOR TREES AND CRITICAL AREAS/BUFFERS.

TP.2. INSTALL TEMPORARY CONSTRUCTION FENCES AROUND THE DRIP LINES OF SINGLE TREES TO BE PRESERVED.

TP.3. INSTALL FENCING AROUND THE EDGE FORMED BY THE DRIP LINES OF A CLUSTER OF TREES TO BE RETAINED. FENCING SHALL BE AT LEAST FOUR FEET HIGH, CONSTRUCTED OF CHAIN LINK, OR POLYETHYLENE LAMINAR SAFETY FENCING OR SIMILAR MATERIAL, SUBJECT TO APPROVAL BY THE DIRECTOR.

TP.4. RETAIN SMALL TREES, BUSHES AND UNDER-STORY PLANTS WITHIN THE TREE PROTECTION ZONE.

TP.5. POST "TREE PROTECTION AREA" SIGNS ON ALL SIDES OF THE FENCED AREAS.

TP.6. DO NOT ALLOW FILL, EXCAVATION, THE STORAGE OF TOOLS, EQUIPMENT, CONSTRUCTION MATERIALS OR STOCKPILE SOIL OR TRAFFIC OR UTILITY CONSTRUCTION INCLUDING IRRIGATION SYSTEMS WITHIN THE DRIP-LINE AREAS OF TREES THAT ARE TO BE RETAINED.

TP.7. PROTECT AS MUCH OPEN SOIL SURFACE BELOW THE TREE'S CROWN (AND OUTSIDE THE FENCED TREE PROTECTION ZONE) AS POSSIBLE.

TP.8. WHEN TRENCHING NEAR PROTECTED TREES, ALLOW ONLY HAND-DIGGING WITHIN THE TREE PROTECTION ZONE. TUNNEL UNDER ROOTS GREATER THAN 1" IN DIAMETER. CLEANLY CUT TORN ROOTS TO THE EDGE OF THE TRENCH. COVER EXPOSED ROOTS WITH VISQUEEN OR LIKE MATERIAL AND KEEP MOIST DURING OPEN GROUND PROCEDURES.

TP.9. PROVIDE 1" OF IRRIGATION WATER PER WEEK TO AS LARGE AN AREA OF ROOT ZONES AS POSSIBLE DURING THE GROWING SEASON AND DRIER MONTHS, APRIL TO OCTOBER. PROVIDING EXTRA WATER FOR PROTECTED TREES IS THE MOST CRITICAL FACTOR IN SAVING TREES DURING AND AFTER CONSTRUCTION.

POST CONSTRUCTION

TP.10. SOIL AERATION MAY BE NECESSARY IN SITUATIONS WHERE COMPACTION HAS OCCURRED. IDENTIFY APPROPRIATE PROCEDURES AND SPECIFICATIONS FROM A CERTIFIED ARBORIST.

TP.11. PRUNE TREES FOLLOWING CONSTRUCTION TO REMOVE DEADWOOD TO ENCOURAGE REGROWTH. TREES SHOULD BE MONITORED THROUGHOUT THE CONSTRUCTION PROCESS FOR ANY INCREASE IN HAZARD POTENTIAL.

STATE GRADING CONDITIONS SG

SG.1. THIS WORK IS BEING APPROVED SUBJECT TO THE CONDITIONS IN THE SHORELINE MUNICIPAL CODE. ALL APPLICABLE CITY, STATE AND FEDERAL REQUIREMENTS APPLY.

SG.2. BEFORE ANY CLEARING OR GRADING OCCURS, MARK CLEARING LIMITS IN A PROMINENT AND DURABLE MANNER. MAINTAIN UNTIL FINAL APPROVAL.

SG.3. NO SLOPE OF CUT AND FILL SURFACES SHALL BE STEEPER THAN IS SAFE FOR THE INTENDED USE AND SHALL NOT EXCEED THREE (3) HORIZONTAL TO ONE (1) VERTICAL, UNLESS OTHERWISE APPROVED.

SG.4. ALL DISTURBED AREAS INCLUDING FACES OF CUT AND FILL SLOPES SHALL BE PREPARED AND MAINTAINED TO CONTROL EROSION. THIS CONTROL MAY CONSIST OF EFFECTIVE PLANTING. THE PROTECTION FOR THESE AREAS SHALL BE INSTALLED AND MAINTAINED AS SOON AS PRACTICAL AND PRIOR TO BOND RELEASE.

SG.5. THE GROUND SURFACE SHALL BE PREPARED TO RECEIVE FILL BY REMOVING UNSUITABLE MATERIAL SUCH AS CONCRETE SLABS, TREE STUMPS AND BRUSH.

SG.6. PROVISIONS SHALL BE MADE TO PREVENT ANY SURFACE WATER OR SEEPAGE FROM DAMAGING THE CUT FACE OF ANY EXCAVATION OR THE SLOPING FACE OF A FILL. CARRY ANY SURFACE WATER THAT IS OR MIGHT BE CONCENTRATED AS A RESULT OF A FILL OR EXCAVATION TO A NATURAL WATERCOURSE OR DESIGNATED RETENTION FACILITY. PREVENT ANY SEDIMENT FROM LEAVING THE SITE.

SG.7. ACCESS ROADS TO GRADING SITES SHALL BE MAINTAINED AND LOCATED TO THE SATISFACTION OF THE CITY OF SHORELINE, TO MINIMIZE THE PROBLEMS OF DUST, MUD AND CIRCULATION.

SG.8. SIGNS OF WARNING OF HAZARDOUS CONDITIONS, IF SUCH EXIST, SHALL BE AFFIXED AT LOCATIONS AS REQUIRED BY THE ENGINEER.

SG.9. FENCING, WHERE REQUIRED, TO PROTECT LIFE, LIMB AND PROPERTY, SHALL BE INSTALLED WITH LOCKABLE GATES WHICH MUST BE CLOSED AND LOCKED WHEN NOT WORKING THE SITE. THE FENCE MUST BE NO LESS THAN FIVE (5) FEET IN HEIGHT AND THE FENCE MATERIAL SHALL HAVE NO HORIZONTAL OPENING LARGER THAN TWO (2) INCHES.

SG.10. THE TOPS AND THE TOES OF CUT AND FILL SLOPES SHALL BE SET BACK FROM STRUCTURES AS FAR AS IS NECESSARY FOR ADEQUACY OF FOUNDATION SUPPORT AND TO PREVENT DAMAGE AS A RESULT OF WATER RUNOFF OR EROSION OF THE SLOPES.

Description	Date	Initials	EM	IBM.VVW	ME	Revisions	Revisions
			Drawn	Designed	Checked	Revisions	Revisions



17500 Midvale Avenue North
 Shoreline, WA 98133
 (206) 801-2700

HIDDEN LAKE CULVERT REPLACEMENT 30 PCT DESIGN - NOT FOR CONSTRUCTION

GENERAL NOTES



Project No. 18-06771-000

Sheet **G-1.2**

Sheet 3 Of 18



Mar 20, 2019 - 3:59pm emarshall C:\proj\18-06771-000\CAD\Draw\Culvert\G-2.0.dwg

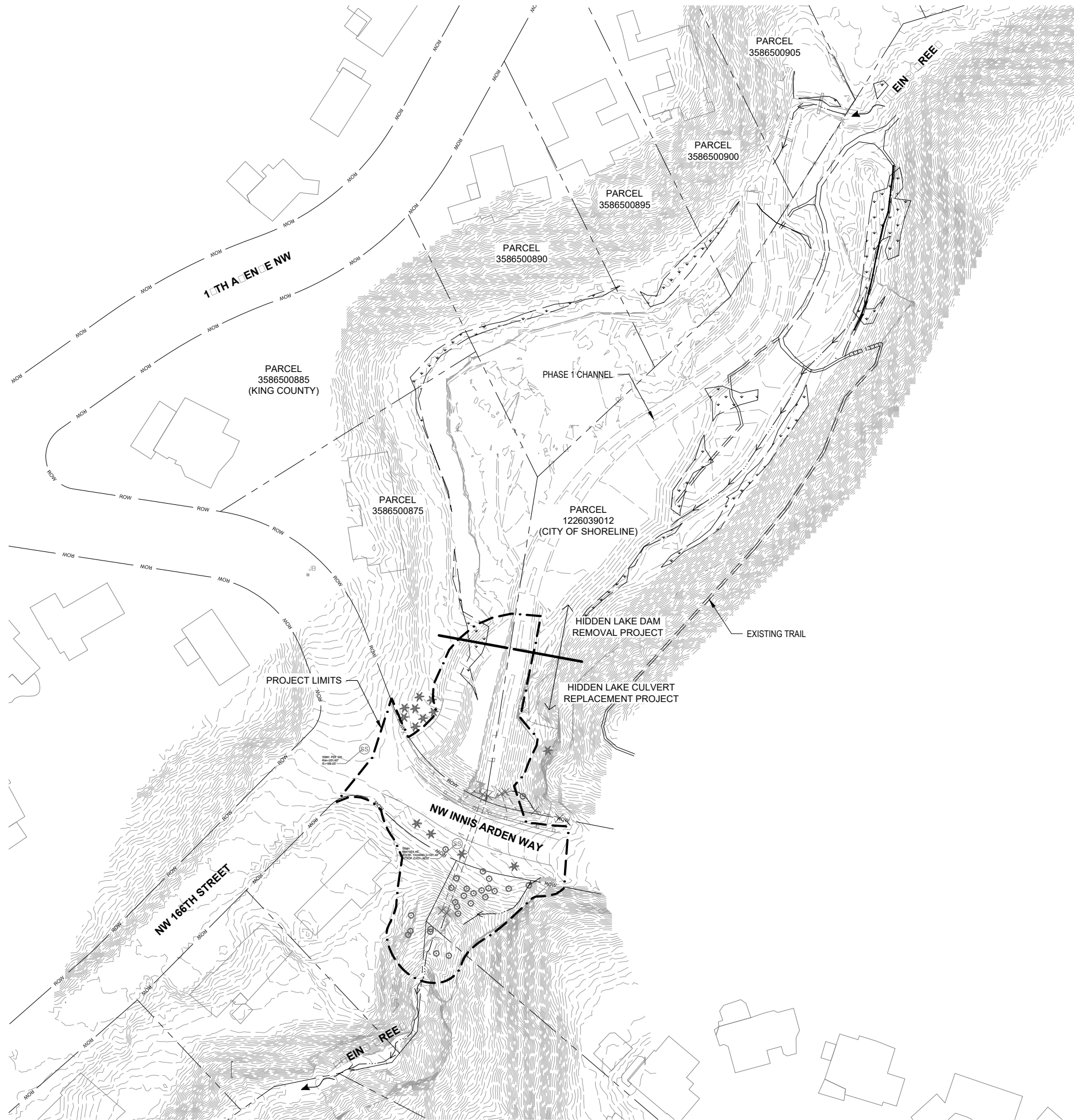

GENERAL NOTES:

- SEE DWG G-1.1 FOR ABBREVIATIONS AND LEGEND.

STATISTICS

EQUIPMENT: TRIMBLE VX ROBOTIC TOTAL STATION.
 METHODOLOGY: FIELD TRAVERSE.
 MEETS OR EXCEEDS SURVEY STANDARD AS PER:
 WAC 332-130-050
 WAC 332-130-090
 WAC 332-130-100

ALL SURVEY WORK OCCURRED IN SEPTEMBER 2015 AND NOVEMBER 2018

SURVEYOR'S NOTES

- ALL UNDERGROUND UTILITY LOCATIONS ARE BASED ON OBSERVED EVIDENCE OF STRUCTURES. THE SURVEYOR MAKES NO GUARANTEE THAT THE UNDERGROUND UTILITIES SHOWN COMPRISE ALL SUCH UTILITIES IN THE AREA, EITHER IN-SERVICE OR ABANDONED. THE SURVEYOR DOES NOT WARRANT THAT THE UNDERGROUND UTILITIES SHOWN ARE IN THE EXACT LOCATION INDICATED ALTHOUGH HE DOES CERTIFY THAT THEY ARE LOCATED AS ACCURATELY AS POSSIBLE FROM THE INFORMATION PROVIDED.
- THIS SURVEY WAS PERFORMED WITHOUT THE BENEFIT OF A COMPLETE TITLE REPORT, WHICH MAY REVEAL ADDITIONAL RESTRICTIONS AND EASEMENTS OF RECORD.

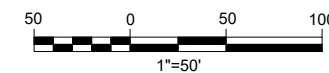

Initials	Date	Description
EM		
IBM, VV		
ME		



17500 Midvale Avenue North
 Shoreline, WA 98133
 (206) 801-2700

HIDDEN LAKE CULVERT
 REPLACEMENT
 30 PCT DESIGN - NOT FOR
 CONSTRUCTION
 EXISTING SITE PLAN

811
 Know what's below.
 Call before you dig.
 ONE INCH AT FULL SIZE
 IF NOT ONE INCH SCALE ACCORDINGLY
 Project No. 18-06771-000

Mar 20, 2019 - 3:59pm emarshall C:\proj\2018\18-06771-000\CAD\Draw\Culvert\C-1.0.dwg

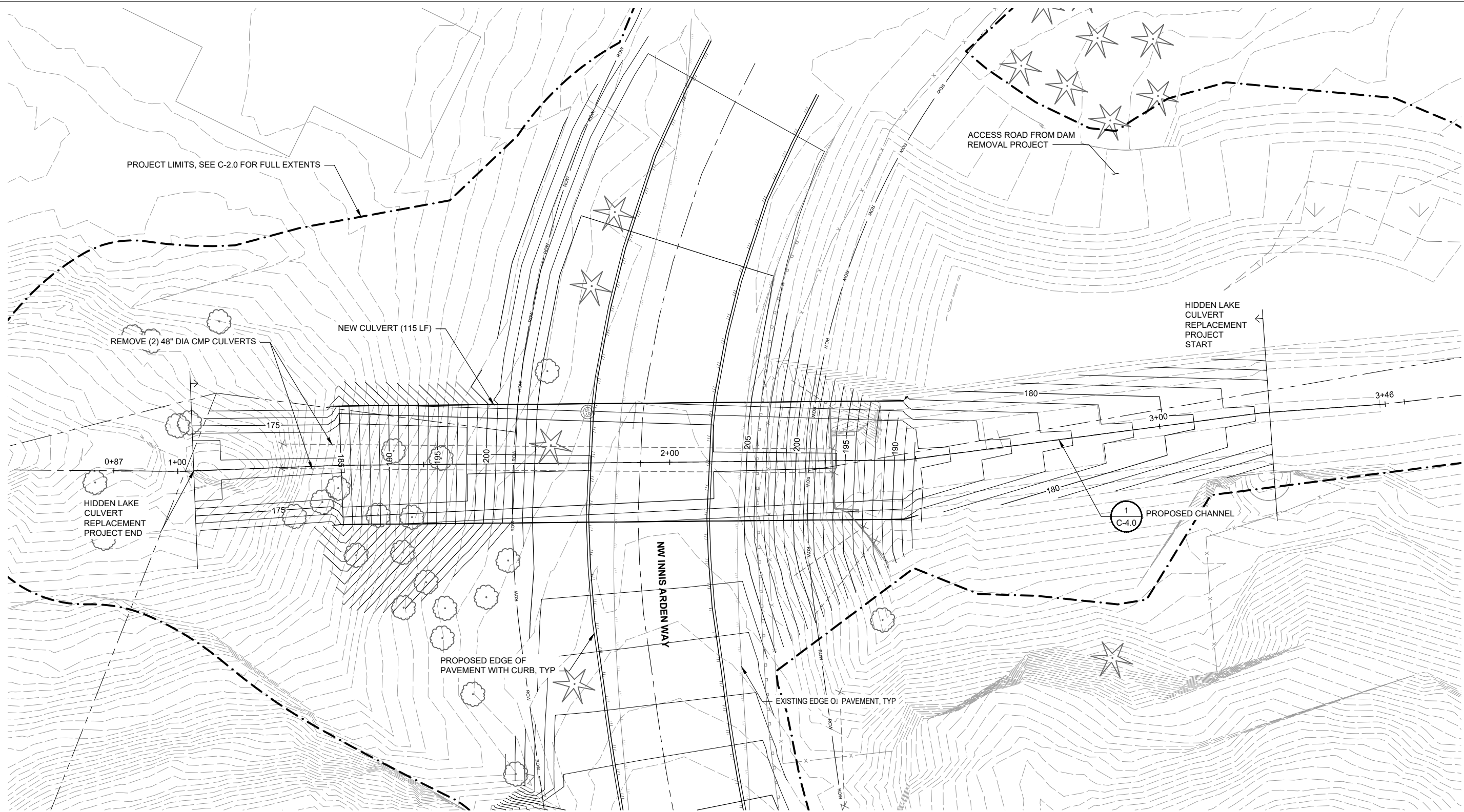

GENERAL NOTES:

1. SEE DWG G-1.1 FOR ABBREVIATIONS AND LEGEND.
2. SEE DWG G-2.0 FOR SURVEY CONTROL.
3. SEE DWG C-2.1 FOR CONSTRUCTION SEQUENCING AND FLOW BYPASS.

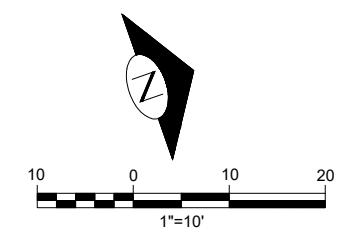

Initials	Date	Description
EM		
IBM, VV		
ME		

Drawn	Designed	Checked	Revisions	Revisions



17500 Midvale Avenue North
Shoreline, WA 98133
(206) 801-2700

**HIDDEN LAKE CULVERT
REPLACEMENT
30 PCT DESIGN - NOT FOR
CONSTRUCTION**
 PROPOSED SITE PLAN

ONE INCH AT FULL SIZE
IF NOT ONE INCH SCALE ACCORDINGLY

Project No. 18-06771-000

Sheet
C-1.0

Sheet 5 Of 18

Mar 20, 2019 - 4:00pm emarshall C:\proj\18-06771-000\CAD\Draw[Culvert]C-2.0.dwg



GENERAL NOTES:

1. SEE DWG G-1.1 FOR ABBREVIATIONS AND LEGEND.
2. SEE DWG XX FOR SURVEY CONTROL.

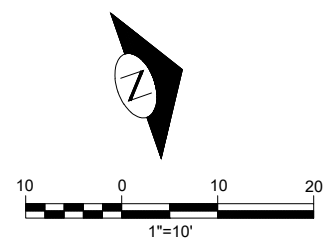

Initials	Date	Description
EM		
IBM, VV		
ME		



17500 Midvale Avenue North
Shoreline, WA 98133
(206) 801-2700

**HIDDEN LAKE CULVERT
REPLACEMENT
30 PCT DESIGN - NOT FOR
CONSTRUCTION**
SITE PREPARATION PLAN AND TESC PLAN



Know what's below.
Call before you dig.
ONE INCH AT FULL SIZE

IF NOT ONE INCH SCALE ACCORDINGLY
Project No. 18-06771-000

Sheet
C-2.0

Mar 20, 2019 - 4:00pm emarshall C:\proj\2018\18-06771-000\CAD\Draw\Culvert\C-2.1.dwg

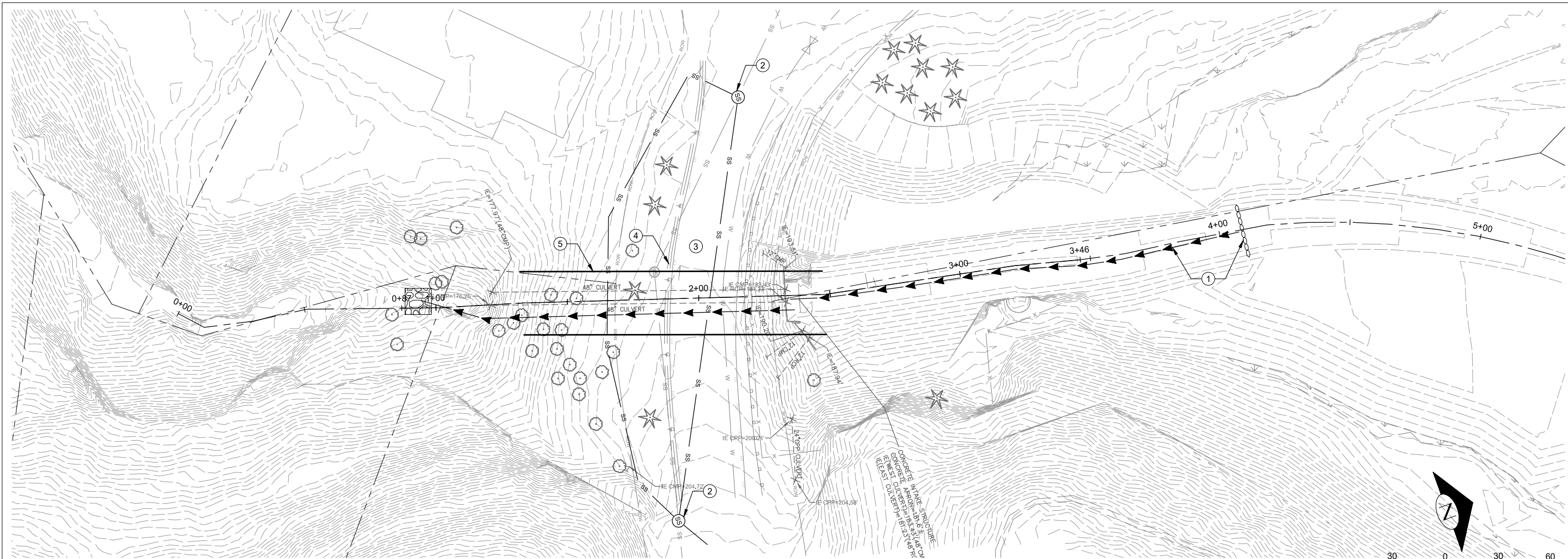

CONSTRUCTION SEQUENCING:

- 1 INSTALL BULK BAG DAM AT THE UPSTREAM END OF THE PROJECT NEAR STATION 4+00. CAPTURE WATER IN A PIPE THAT CONNECTS INTO THE EXISTING CULVERTS UNDER NW INNIS ARDEN WAY.
- 2 INSTALL NEW STORM SEWER MANHOLE PER PLAN.
- 3 REMOVE THE ROADWAY SURFACE INSIDE THE DISTURBANCE LIMITS OF INNIS ARDEN WAY. BEGIN EXCAVATION OVER THE CULVERTS DOWN TO ELEVATION 187 FEET.
- 4 RELOCATE, BYPASS, OR ABANDON UTILITIES AS THEY ARE ENCOUNTERED.
- 5 INSTALL SOLDIER PILES AND LAGGING AS EXCAVATION DEEPENS TO EXPOSE EXISTING CULVERTS.
- 6 PROVIDE A TEMPORARY FLOW BYPASS PIPE OR OTHER MEANS OF BYPASSING FLOW THROUGH THE EXCAVATION WHILE REMOVING THE EXISTING CULVERTS.
- 7 COMPLETE STREAM CHANNEL EXCAVATION AND STREAMBED MATERIAL PLACEMENT.
- 8 PLACE CONCRETE FASCIA WALLS AND PLACE THE LID ON TOP OF THE CULVERT. BACKFILL OVER THE TOP OF THE CULVERT AND RECONSTRUCT THE ROAD PRISM.
- 9 REMOVE THE BULK BAG DAM AND FLOW BYPASS FROM THE STREAM, RESTORING FLOW IN THE NEW STREAM CHANNEL.

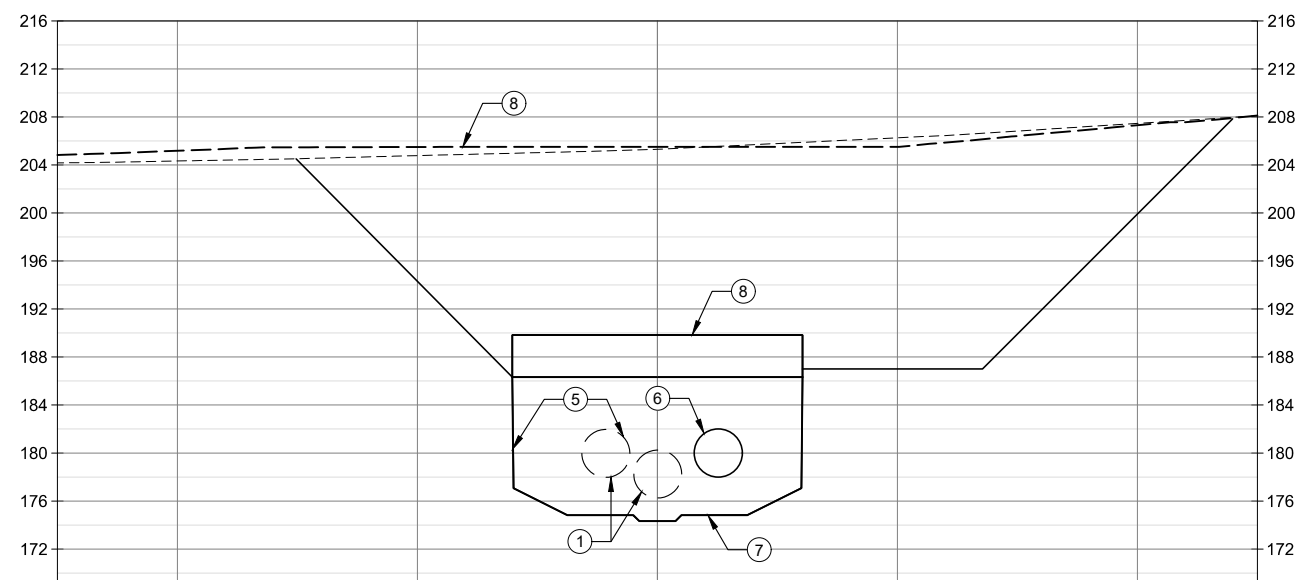

Initials	Date	Description
EM		
IBM, VV		
ME		

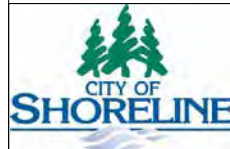

17500 Midvale Avenue North
Shoreline, WA 98133
(206) 801-2700

HIDDEN LAKE CULVERT REPLACEMENT 30 PCT DESIGN - NOT FOR CONSTRUCTION
 STREAMFLOW BYPASS PLAN AND CONSTRUCTION SEQUENCING

 Know what's below.
 Call before you dig.
 ONE INCH AT FULL SIZE
 IF NOT ONE INCH SCALE ACCORDINGLY
 Project No. 18-06771-000
 Sheet C-2.1
 Sheet 7 Of 18



GENERAL NOTES:

1. DURING CONSTRUCTION CONTRACTOR MAY USE NEW SSMH A FOR TEMPORARY SEWER BYPASS PUMPS AND PIPING. APPROXIMATE SEWER FLOW TO BE PUMPED DURING CONSTRUCTION IS 125 GPM (25 GPM FROM EXIST 8" DIAM GRAVITY SEWER AND 100 GPM FROM EXIST 8" DIAM SIPHON)
2. DURING CONSTRUCTION CONTRACTOR MAY USE NEW SSMH B FOR TEMPORARY SEWER BYPASS DISCHARGE.
3. LOCATION OF TEMPORARY SEWER BYPASS PIPE IS APPROXIMATE. CONTRACTOR SHALL DETERMINE TEMPORARY BYPASS PIPE ALIGNMENT BASED ON PERMITTING AND OPERATIONS REQUIREMENTS.
4. EXISTING SIPHON PARALLELS EXISTING 8" DIAMETER GRAVITY SEWER, AND IS ASSUMED TO OFFLOAD FLOWS FROM GRAVITY SEWER. INFORMATION ON SIPHON IS FROM GIS-ELEVATIONS ARE UNKNOWN. CONTRACTOR SHALL CONFIRM LOCATION PRIOR TO CONSTRUCTION.
5. NEW SS PIPE ALIGNMENT IS SHOWN ON SHEET C-3.1.
6. CUT AND CAP EXISTING WATER LINE ON BOTH SIDES OF EXCAVATION LIMITS. REMOVE PIPE DURING CULVERT CONSTRUCTION. REPLACE WATER LINE WITH 8" DI PIPE AND PRESSURE TEST PRIOR TO COMPLETION OF CONSTRUCTION.
7. EXISTING GAS LINE REMOVAL AND REPLACEMENT WILL BE DONE BY PSE. CONTRACTOR SHALL COORDINATE CONSTRUCTION WITH PSE.
8. TEMPORARY RELOCATION OF EXISTING TELECOM WILL BE DONE BY OTHERS. CONTRACTOR SHALL COORDINATE CONSTRUCTION.

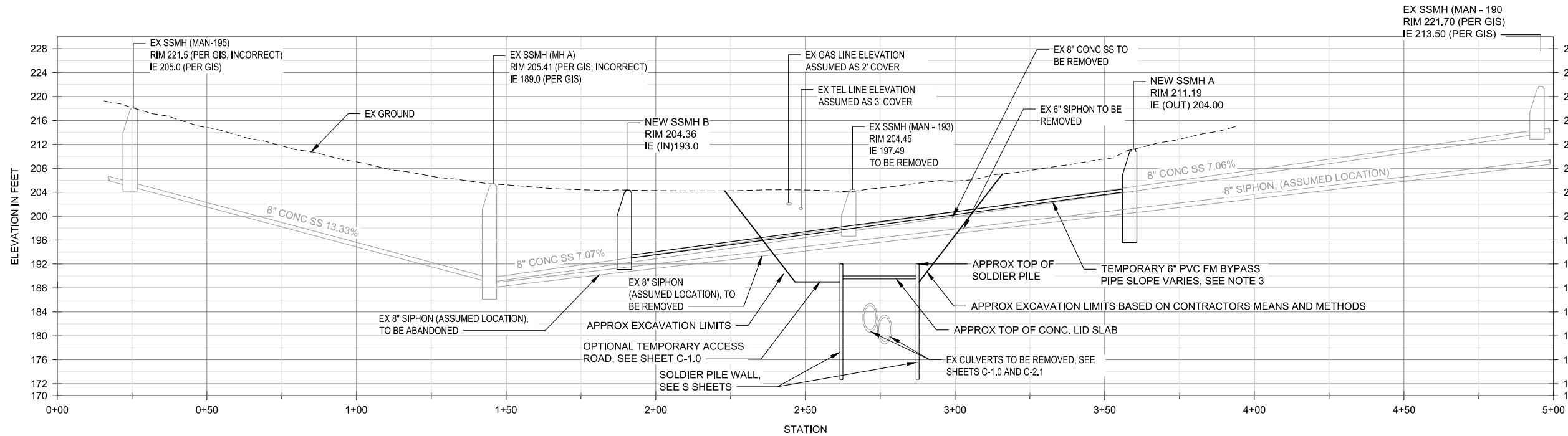
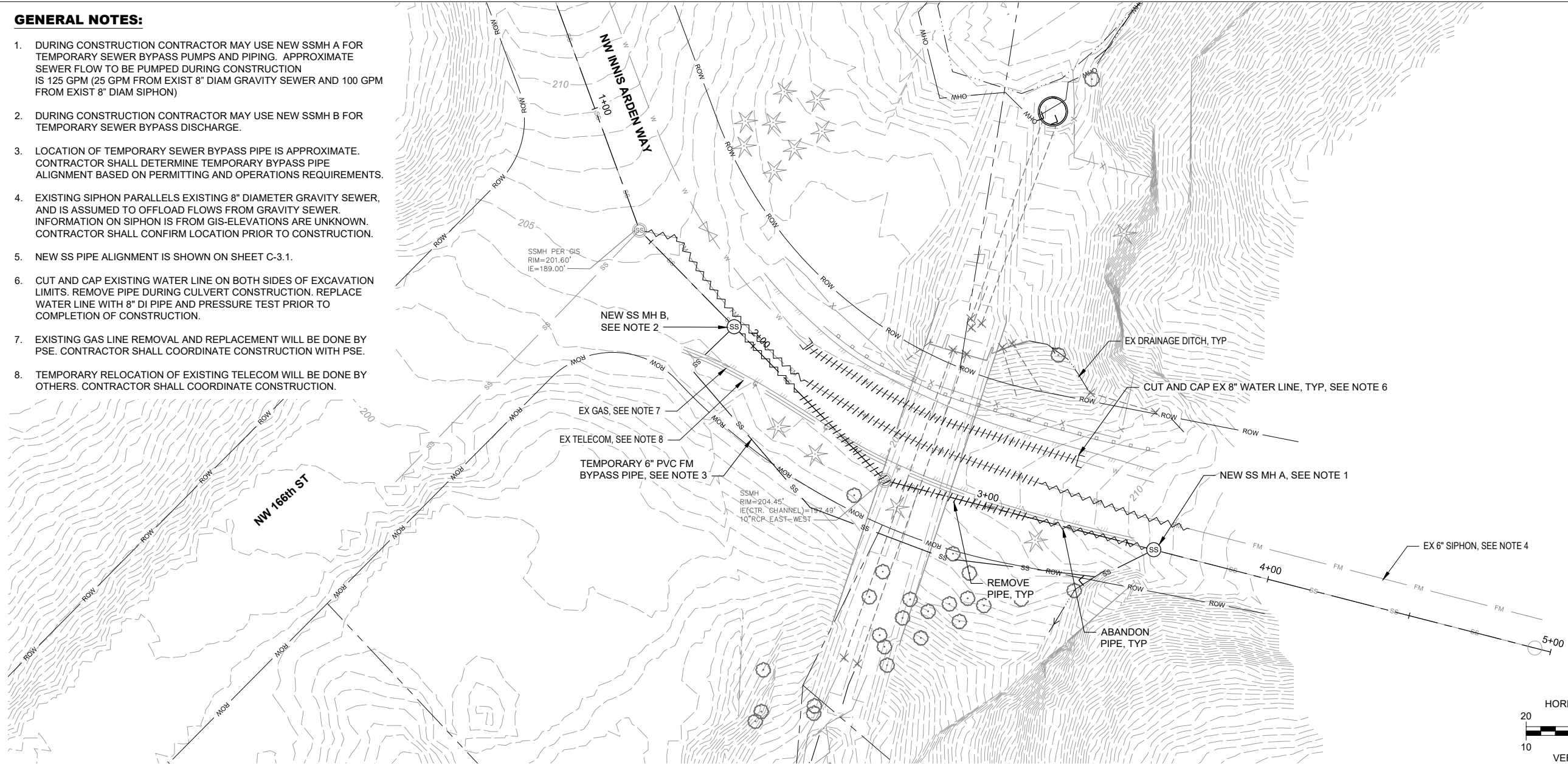

Initials	Date	Description
EM		
IBM, VW		
ME		

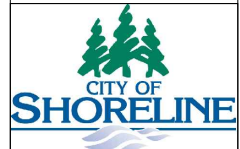

17500 Midvale Avenue North
Shoreline, WA 98133
(206) 801-2700

**HIDDEN LAKE CULVERT
REPLACEMENT
30 PCT DESIGN - NOT FOR
CONSTRUCTION**
UTILITY PROTECTION AND REMOVAL PLAN

Project No. 18-06771-000
Sheet C-3.0
Sheet 8 Of 18



Mar 28, 2019 - 1:43pm emarshall C:\proj\18-06771-000\CAD\DWG\Culvert\C-3.0.dwg

GENERAL NOTES:

1. REMOVE TEMPORARY BYPASS PUMPING EQUIPMENT FROM NEW SSMH A AFTER CONSTRUCTION OF NEW 8" SS IS COMPLETE AND NEW SS IS OPERATIONAL.
2. EXISTING SIPHON PARALLELS EXISTING 8" DIAMETER GRAVITY SEWER, AND IS ASSUMED TO OFFLOAD FLOWS FROM GRAVITY SEWER. INFORMATION ON SIPHON IS FROM GIS, ELEVATIONS ARE UNKNOWN AND PIPE IS NOT SHOWN IN PROFILE. CONTRACTOR SHALL CONFIRM LOCATION PRIOR TO CONSTRUCTION.
3. COLD BEND PIPE TO MAINTAIN 10' CLEARANCE FROM WATER LINE TO THE NORTH. BENDING RADIUS NOT TO EXCEED MANUFACTURER'S RECOMMENDATIONS.
4. EXISTING WATER LINE ELEVATIONS ARE UNKNOWN. NEW WATER LINE SHALL BE INSTALLED TO MATCH EXISTING ELEVATIONS AT CONNECTIONS.

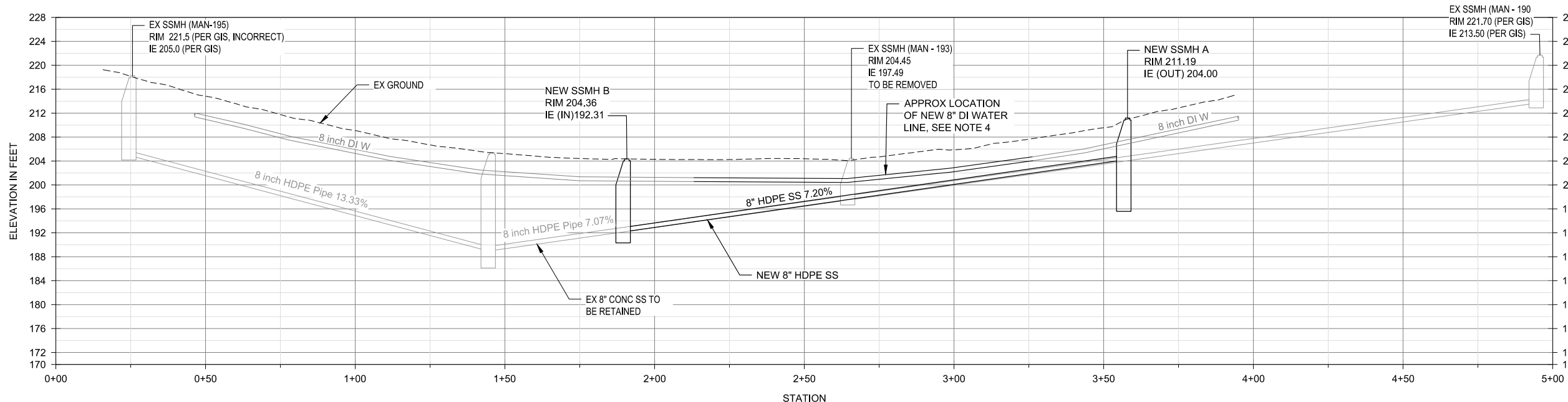
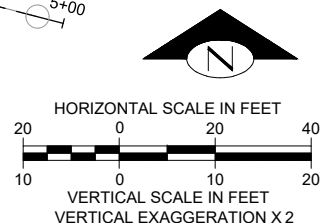
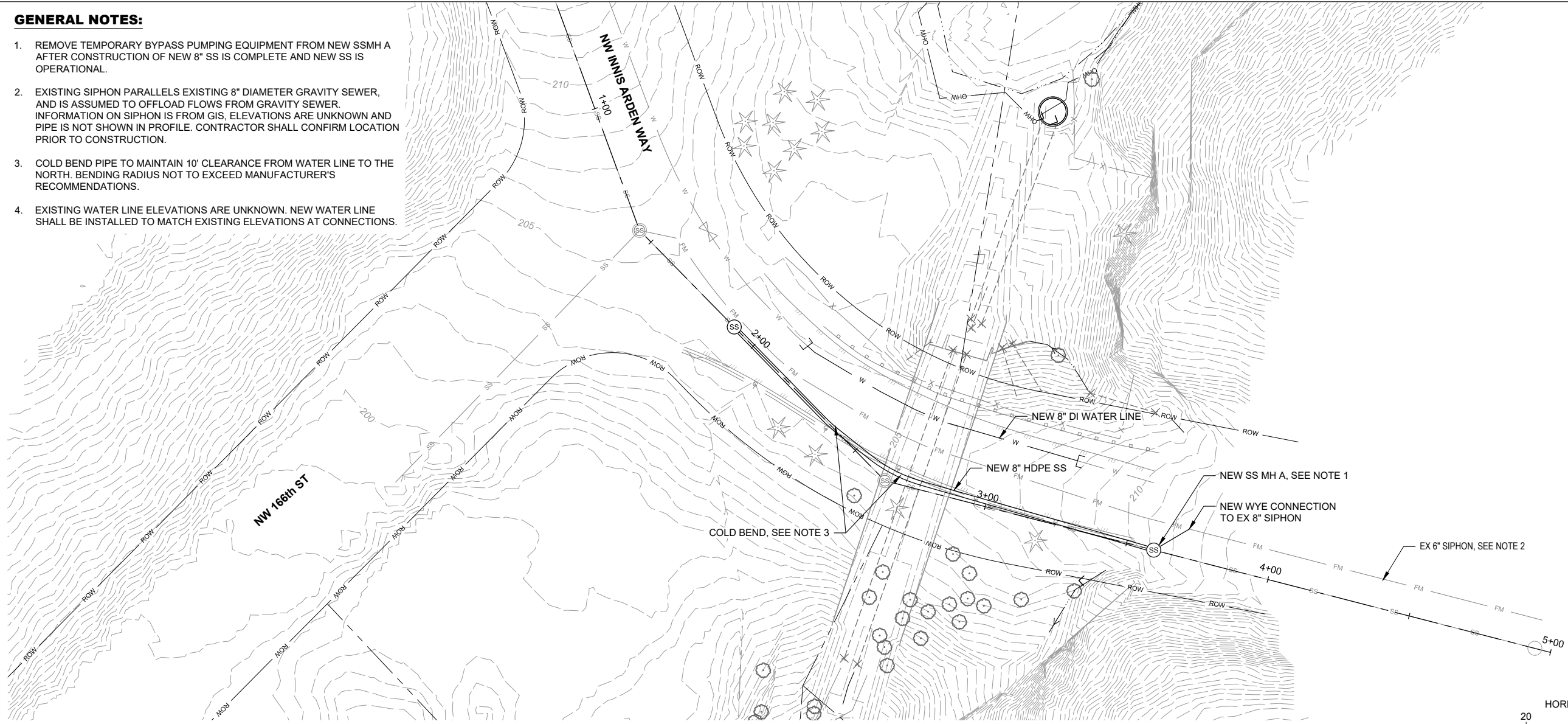

Initials	Date	Description
EM		
IBM, VW		
ME		

Drawn	Designed	Checked	Revisions	Revisions



17500 Midvale Avenue North
Shoreline, WA 98133
(206) 801-2700

**HIDDEN LAKE CULVERT
REPLACEMENT
30 PCT DESIGN - NOT FOR
CONSTRUCTION**
 UTILITY RELOCATION PLAN



Know what's below.
Call before you dig.
ONE INCH AT FULL SIZE
IF NOT ONE INCH SCALE ACCORDINGLY

Project No. 18-06771-000

Sheet

C-3.1



Mar 28, 2019 - 1:43pm emarshall C:\proj\2018\18-06771-000\CAD\Draw\Culvert\C-3.0.dwg

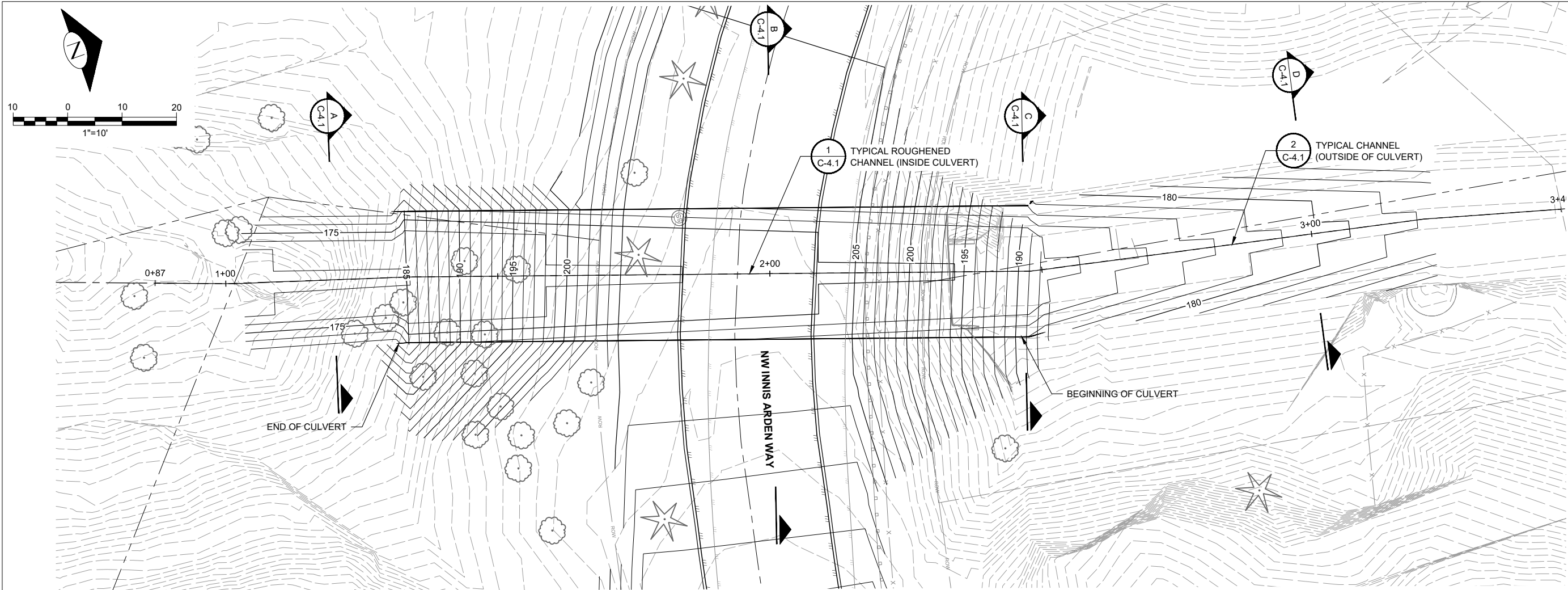

Initials	Date	Description
EM		
IBM, VV		
ME		
		Revisions
		Revisions



17500 Midvale Avenue North
Shoreline, WA 98133
(206) 801-2700

**HIDDEN LAKE CULVERT
REPLACEMENT
30 PCT DESIGN - NOT FOR
CONSTRUCTION**
CULVERT REPLACEMENT PLAN AND PROFILE

Project No. 18-06771-000

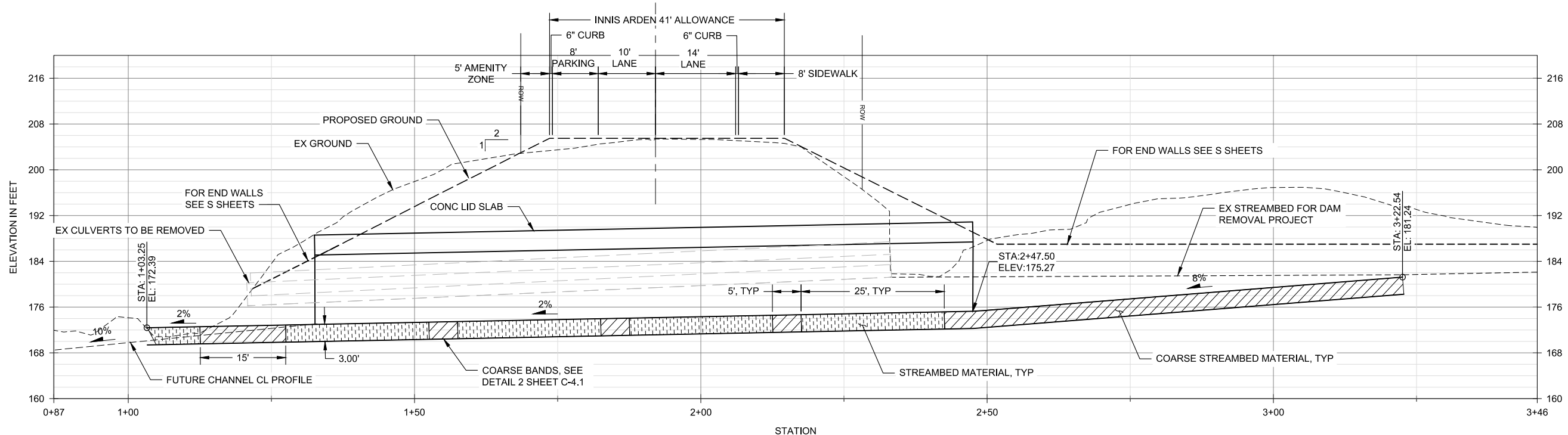

NOTES:

GENERAL NOTES:

- SEE DWG G-1.1 FOR ABBREVIATIONS AND LEGEND.
- SEE DWG G-2.0 FOR SURVEY CONTROL.



Mar 20, 2019 - 4:01pm
 emarshall
 C:\proj\2018\18-06771-000\CAD\Draw\Culvert\C-4.0.dwg

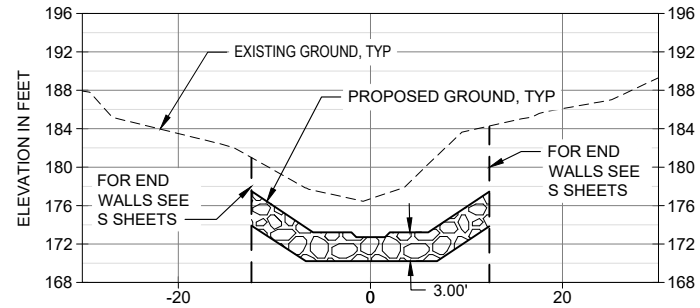

**SECTION A TRANSITION TO
EXISTING CHANNEL REAR**

HORIZ. SCALE: 1"=10'
VERT. SCALE: 1"=10'

A
C-4.0

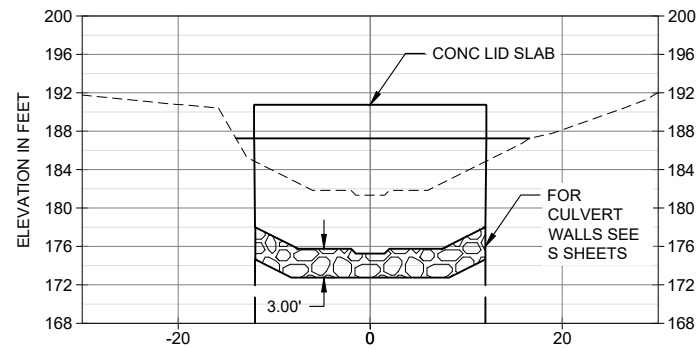

SECTION B LERT AREA REAR

HORIZ. SCALE: 1"=10'
VERT. SCALE: 1"=10'

B
C-4.0

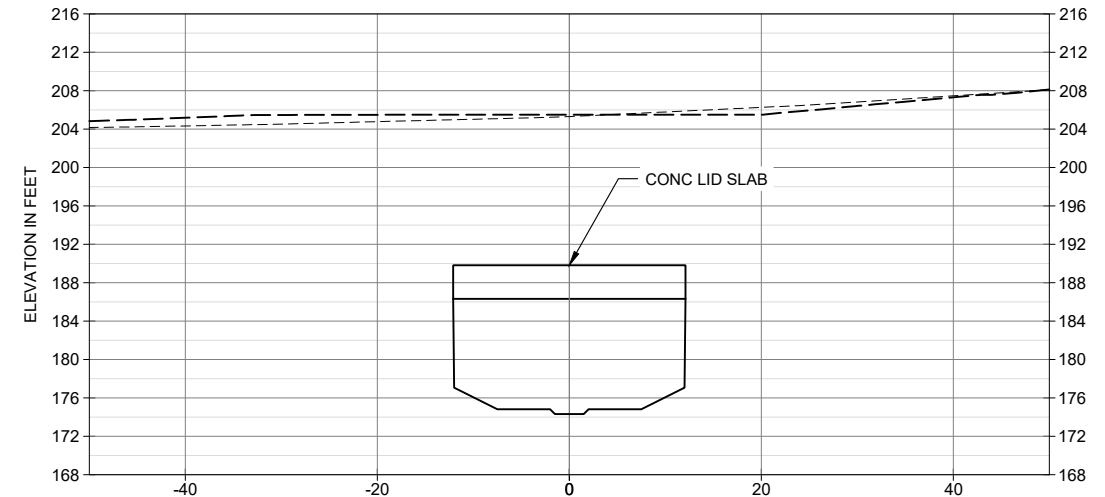

SECTION B LERT AREA

HORIZ. SCALE: 1"=10'
VERT. SCALE: 1"=10'

B
C-4.0

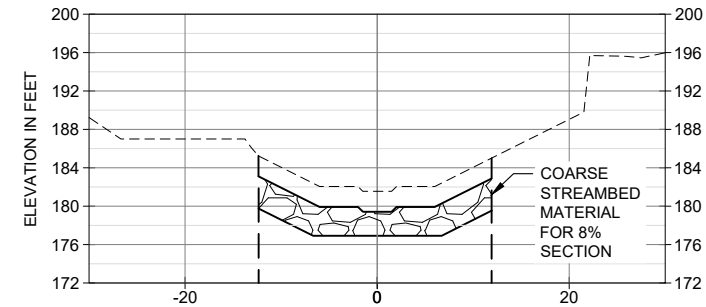

SECTION D SLOPE AREA

HORIZ. SCALE: 1"=10'
VERT. SCALE: 1"=10'

D
C-4.0

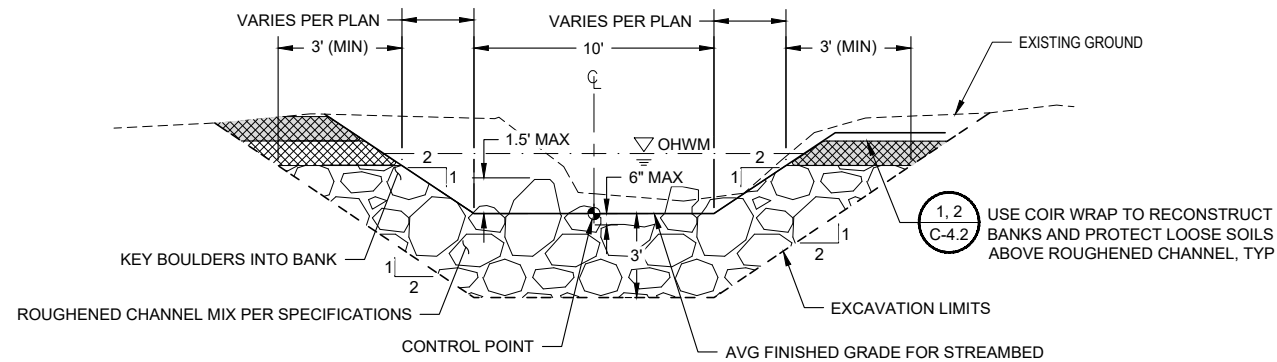

DETAIL 1 CHANNEL ROUGHENED CHANNEL

SCALE: NTS

1
C-4.0

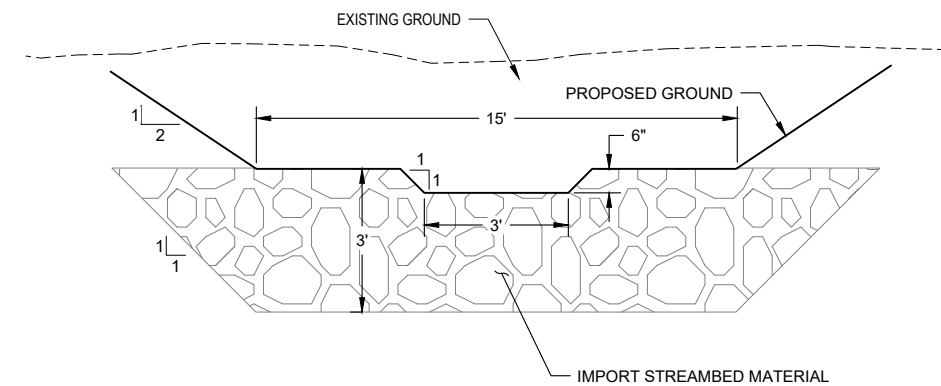

DETAIL 2 CHANNEL

SCALE: NTS

2
C-4.0



17500 Midvale Avenue North
Shoreline, WA 98133
(206) 801-2700

HIDDEN LAKE CULVERT
REPLACEMENT
30 PCT DESIGN - NOT FOR
CONSTRUCTION
CULVERT REPLACEMENT SECTIONS



Know what's below.
Call before you dig.

ONE INCH AT FULL SIZE

IF NOT ONE INCH SCALE ACCORDINGLY

Project No. 18-06771-000

Sheet

C-4.1

Sheet 11 Of 18



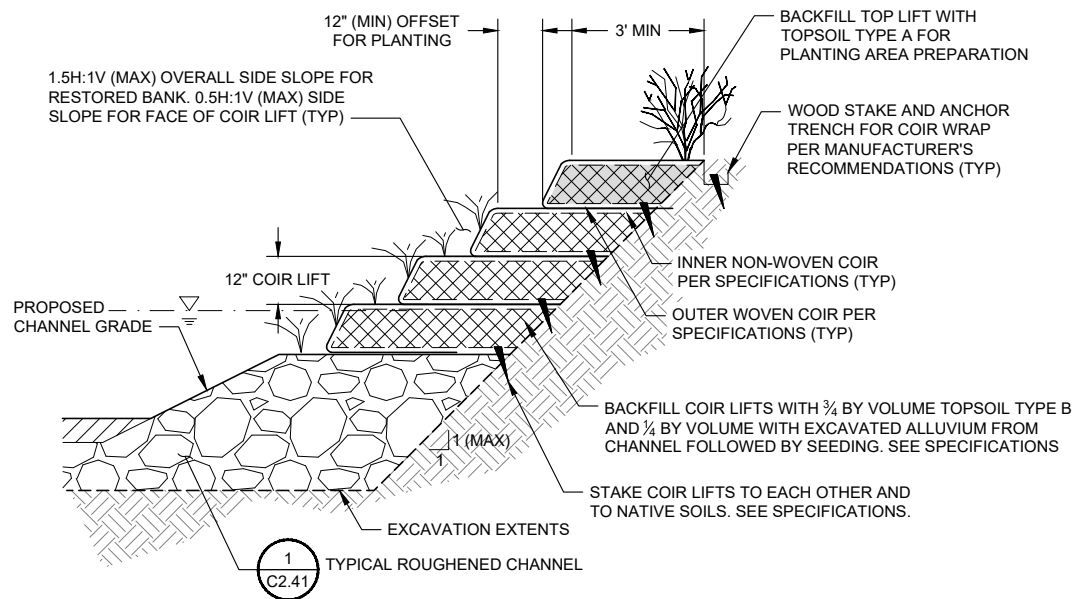

DETAIL 1 TYPICAL TERRACED AND RESTORATION OR STEEP SLOPES
SCALE: NTS

1
C2.41

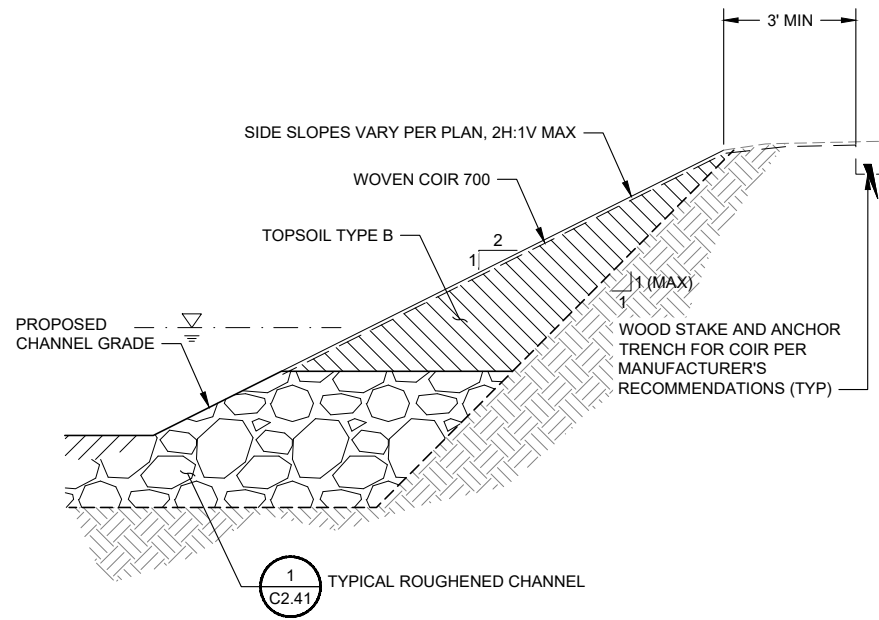

DETAIL 2 TYPICAL CHANNEL RESTORATION OR SHALLOW SLOPES
SCALE: NTS

2
C2.41

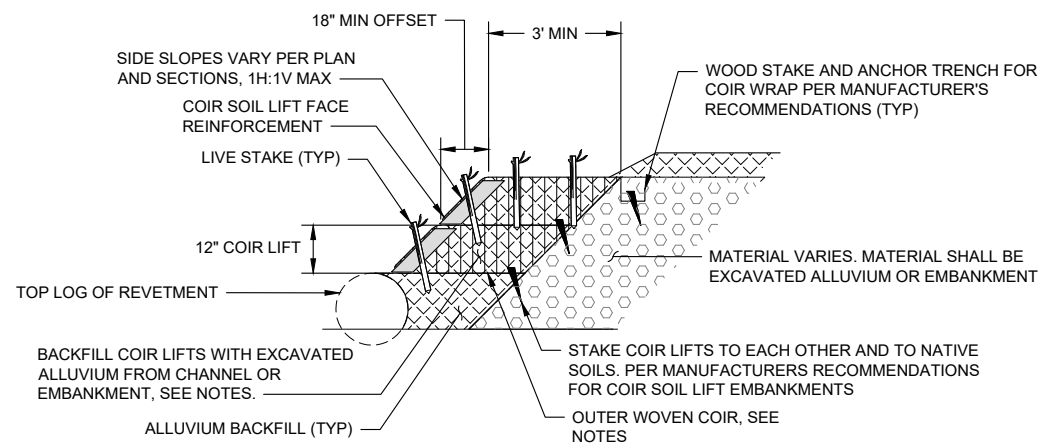

DETAIL 3 TYPICAL SOIL LIFT EMBANKMENT
SCALE: NTS

3
-

COIR REPAIR REARATION
(SEE SPECIFICATIONS)

- STEP 1**
- OVEREXCAVATE TO PLACE COIR WRAP SOIL LIFTS
 - PROTECT SUBGRADE FROM FOOT TRAFFIC AND CONSTRUCTION ACTIVITIES THAT COULD CAUSE SOIL DISTURBANCE OR BANK SETTLEMENT PRIOR TO COIR PLACEMENT
- STEP 2**
- PLACE OUTER WOVEN COIR FOR THE BOTTOM OF THE LIFT
 - PLACE INNER NON-WOVEN COIR
 - STAKE COIR FABRIC TO NATIVE SOIL BELOW LIFT
- STEP 3**
- INSTALL FORM (IF CONTRACTOR CHOOSES) TO HOLD COIR WRAP AND SOIL TO DESIGN DIMENSIONS
 - PLACE 12" HIGH LAYER OF SOIL COMPOSED OF TOPSOIL TYPE D AMENDED WITH ALLUVIUM AND COMPACT PER SPECIFICATIONS
- STEP 4**
- PLACE SEED MIX PER PLANTING PLAN AND SPECIFICATIONS
- STEP 5**
- WRAP OUTER WOVEN COIR AND INNER NON-WOVEN COIR AROUND SOIL LIFT TO ENCASE THE LIFT
- STEP 6**
- STAKE PER COIR MANUFACTURER'S RECOMMENDATION

GENERAL NOTES:

- SEE DWG G0.01 FOR ABBREVIATIONS AND LEGEND.

Initials	Date	Description
EM		
IBM, VV		
ME		
		Revisions
		Revisions

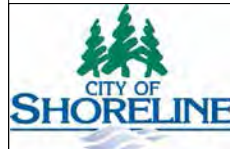

17500 Midvale Avenue North
Shoreline, WA 98133
(206) 801-2700

HIDDEN LAKE CULVERT
REPLACEMENT
30 PCT DESIGN - NOT FOR
CONSTRUCTION
BANK AND COIR DETAILS



Know what's below.
Call before you dig.

ONE INCH AT FULL SIZE

IF NOT ONE INCH SCALE ACCORDINGLY

Project No. 18-06771-000

Sheet

C-4.2

Sheet 12 Of 18



Mar 20, 2019 - 4:01pm emarshall C:\proj\2018\18-06771-000\CAD\Draw\Culvert\C-4.2.dwg

Mar 20, 2019 - 4:02pm emarshall O:\proj\Y2018\18-06771-000\CAD\Draw\Culvert\L-1.0.dwg

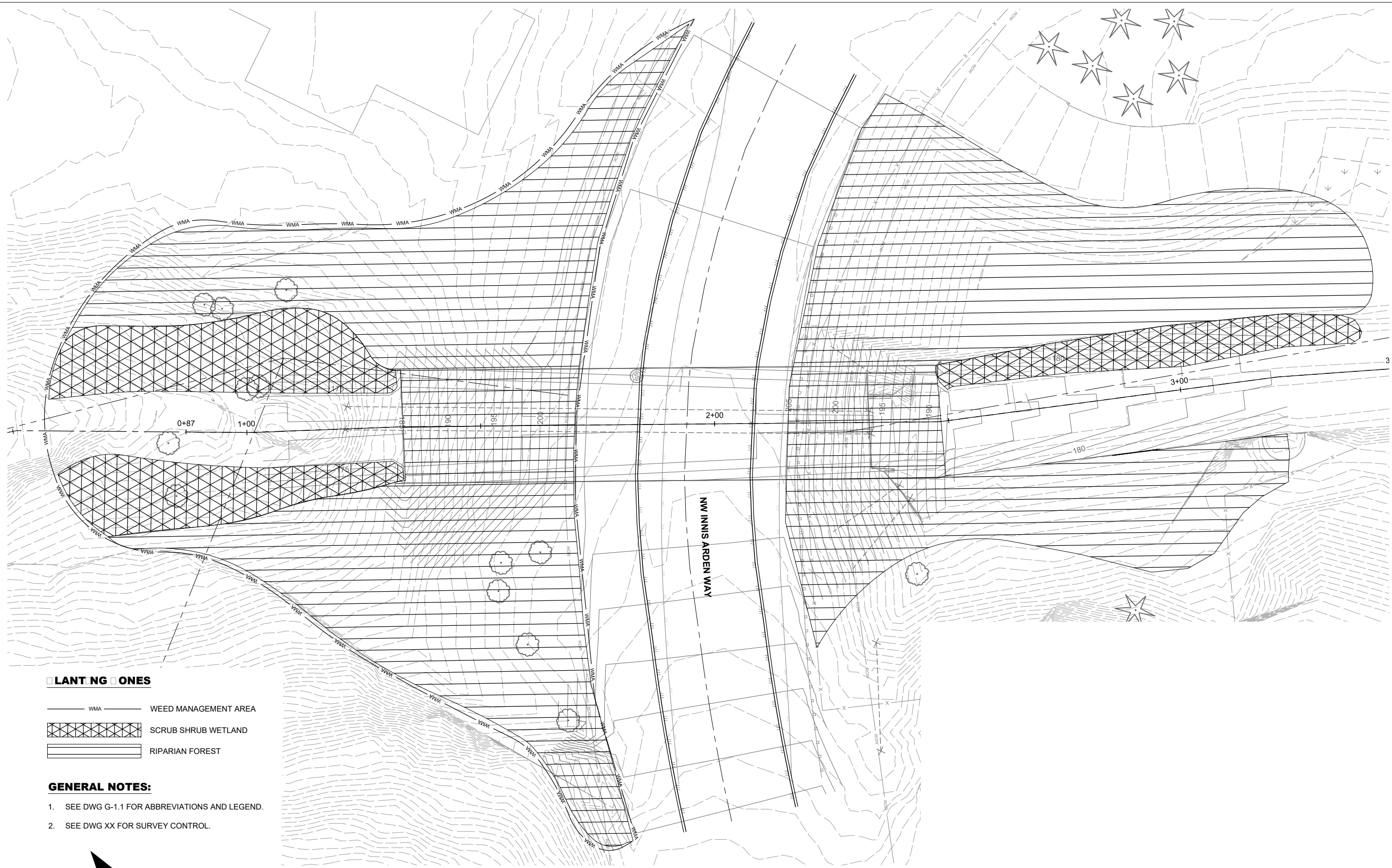

- LANT NG □ ONES
- WMA — WEED MANAGEMENT AREA
- ▨ SCRUB SHRUB WETLAND
- ▩ RIPARIAN FOREST

- GENERAL NOTES:**
- SEE DWG G-1.1 FOR ABBREVIATIONS AND LEGEND.
 - SEE DWG XX FOR SURVEY CONTROL.

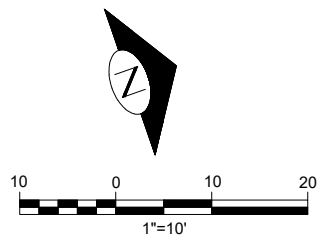

Initials	Date	Description
EM		
IBM, VW		
ME		



17500 Midvale Avenue North
Shoreline, WA 98133
(206) 801-2700

**HIDDEN LAKE CULVERT
REPLACEMENT
30 PCT DESIGN - NOT FOR
CONSTRUCTION**
PLANTING PLAN

Project No. 18-06771-000



Mar 20, 2019 - 2:05pm thedgjin C:\pw_workdir\den003\ch2mhill_theadgin\0456071\S-1.dwg

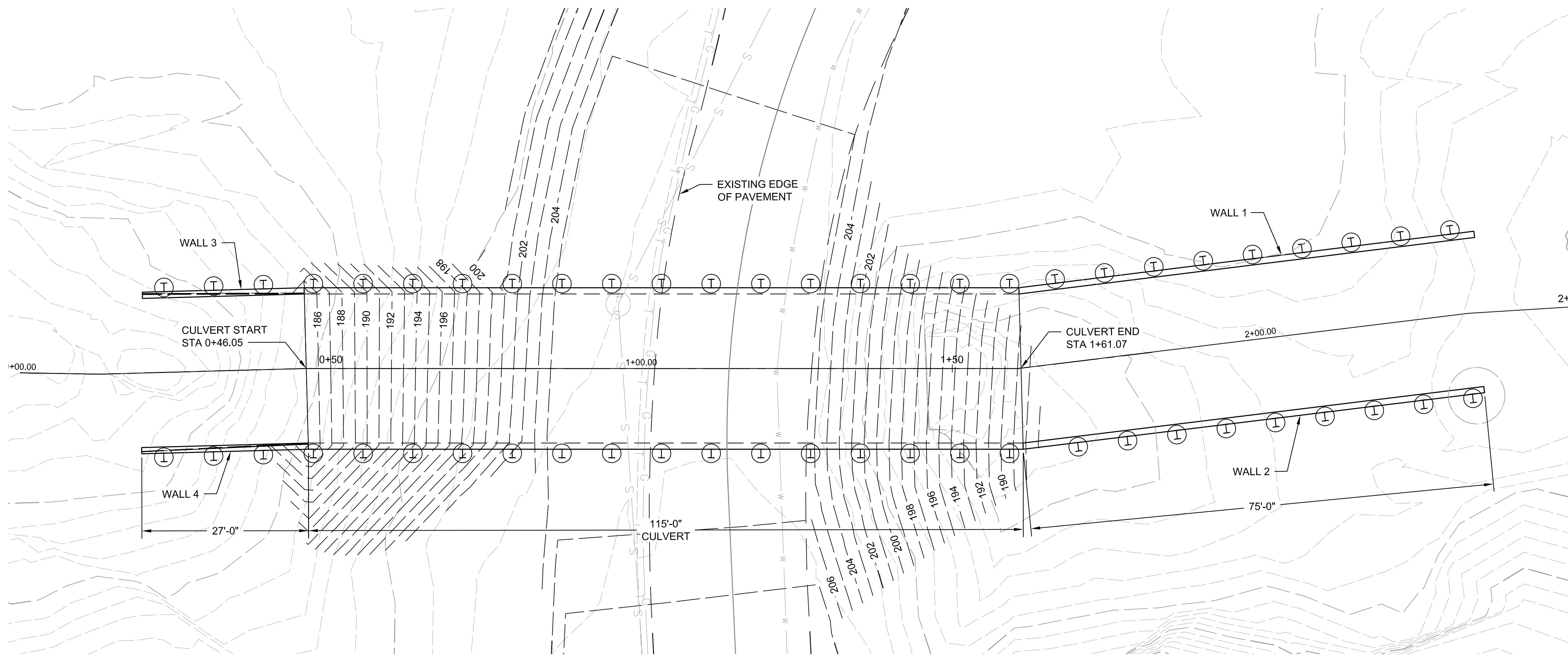

PLAN

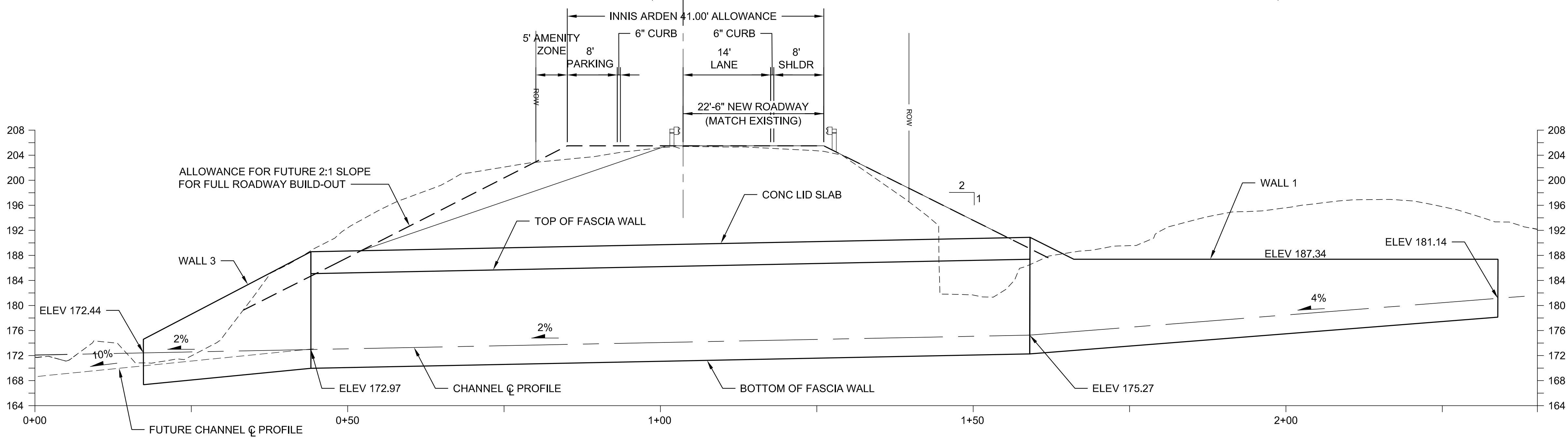

PROFILE

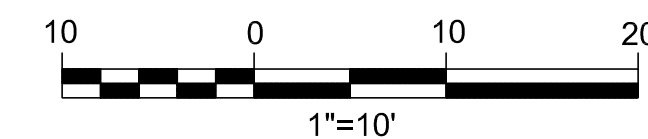

HERRERA

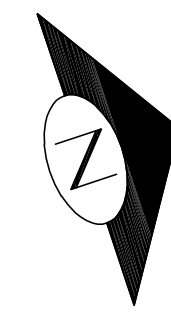

Initials	Date	Description
EM		
IBM, VW		
ME		



17500 Midvale Avenue North
Shoreline, WA 98133
(206) 801-2700

**HIDDEN LAKE CULVERT
REPLACEMENT
30 PCT DESIGN - NOT FOR
CONSTRUCTION**



Project No. 18-06771-000

Sheet **S-1**
Sheet 14 Of 18

Mar 20, 2019 - 2:09pm thedgjin C:\pw_workdir\den003\ch2mhill_theogjin\d0456071\S-2.dwg

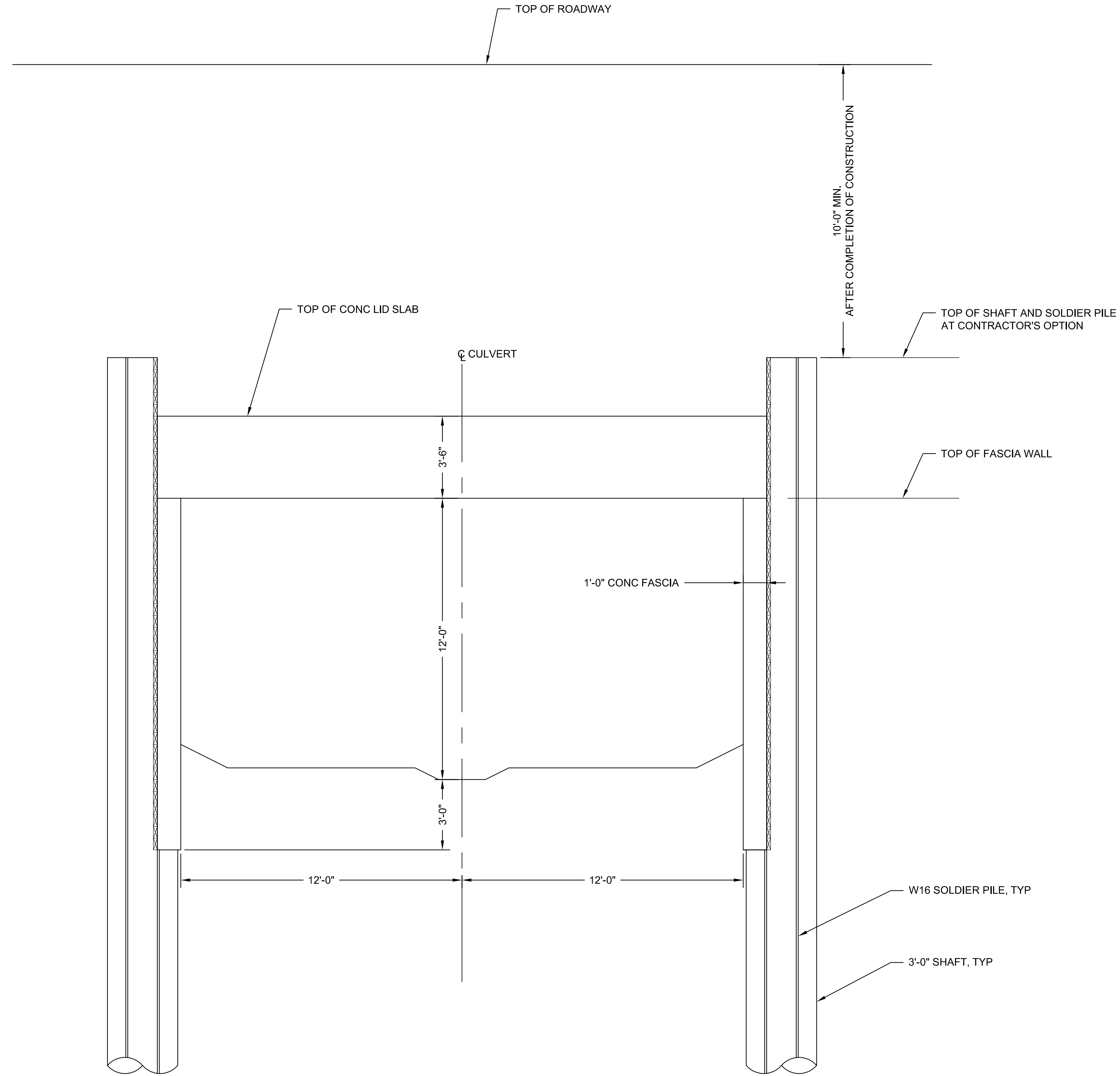

TYPICAL SECTION

Initials	Date	Description
EM		
IBM, VW		
ME		

Drawn	Designed	Checked	Revisions	Revisions



17500 Midvale Avenue North
Shoreline, WA 98133
(206) 801-2700

**HIDDEN LAKE CULVERT
REPLACEMENT
30 PCT DESIGN - NOT FOR
CONSTRUCTION**
TYPICAL SECTION



Know what's below.
Call before you dig.

ONE INCH AT FULL SIZE

IF NOT ONE INCH SCALE ACCORDINGLY

Project No. 18-06771-000

Sheet **S-2**

Sheet 15 Of 18



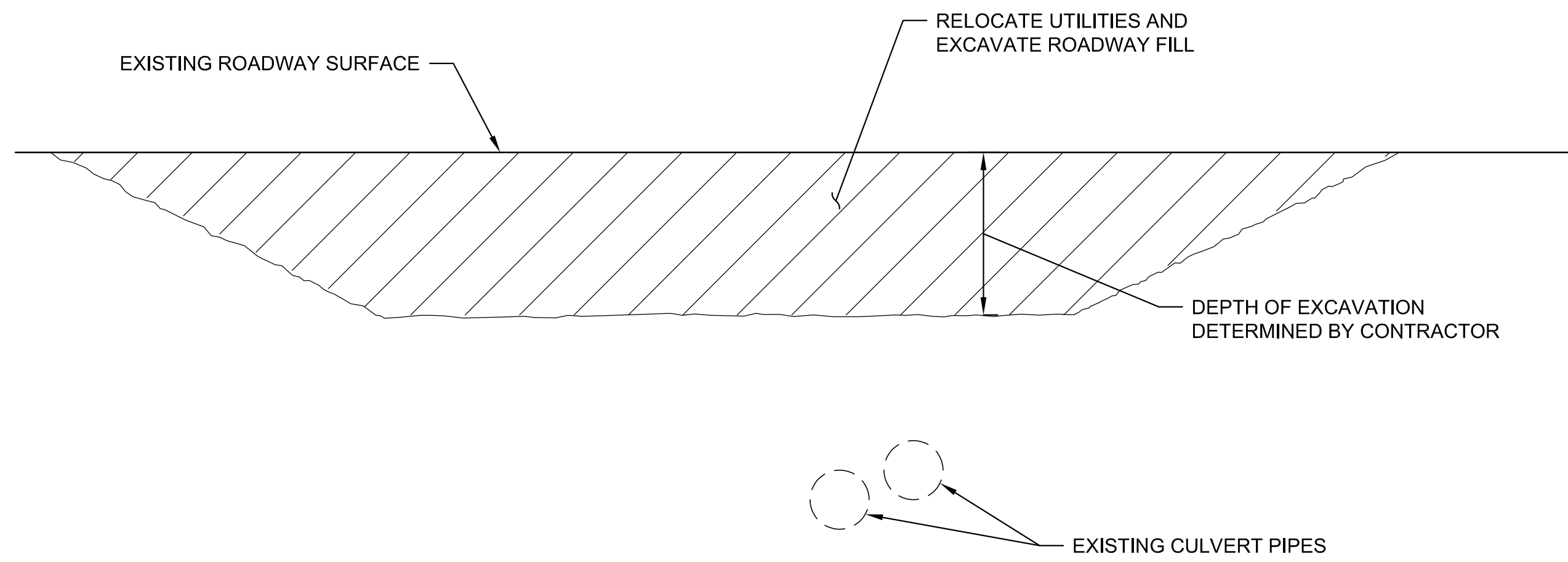

STEP 1

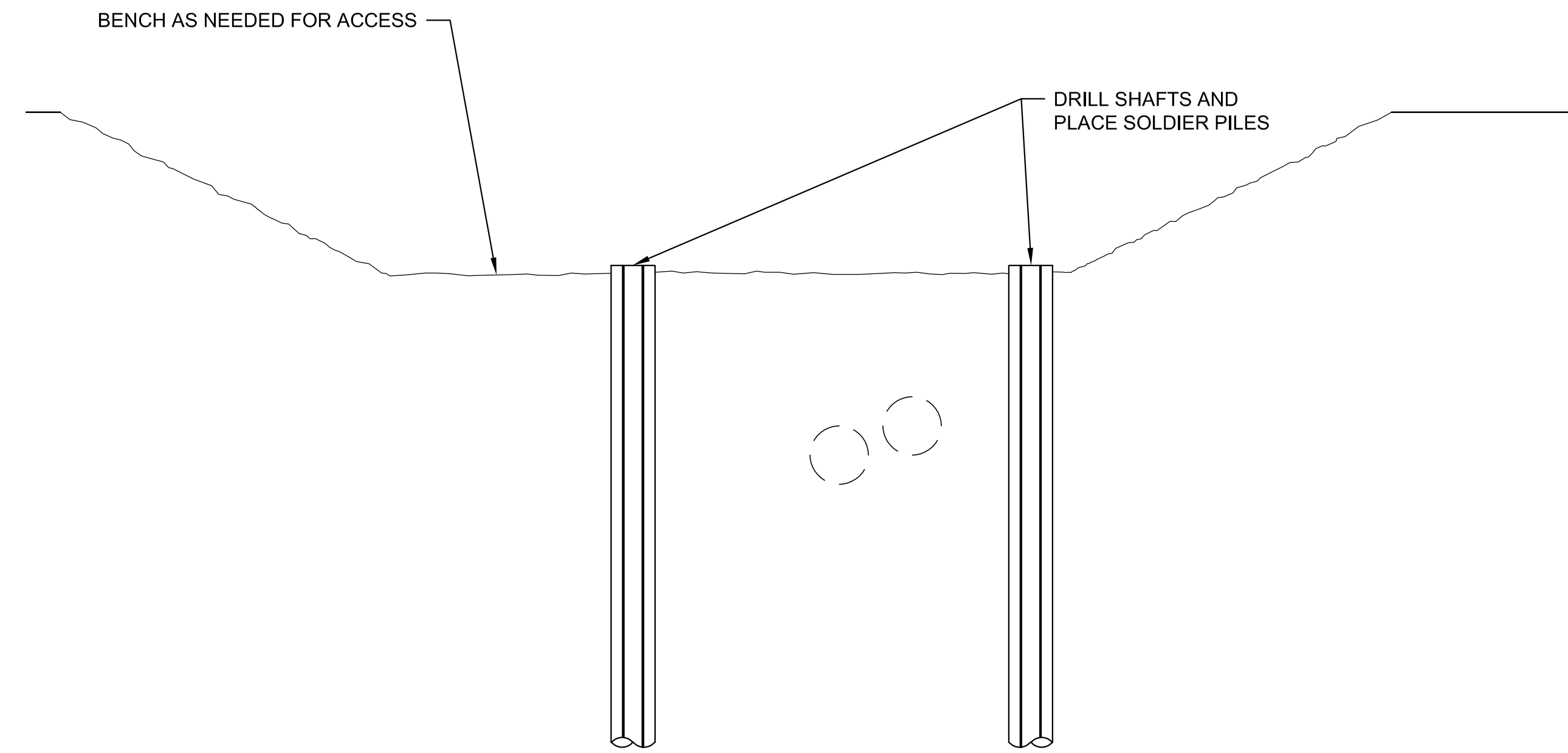

STEP 2

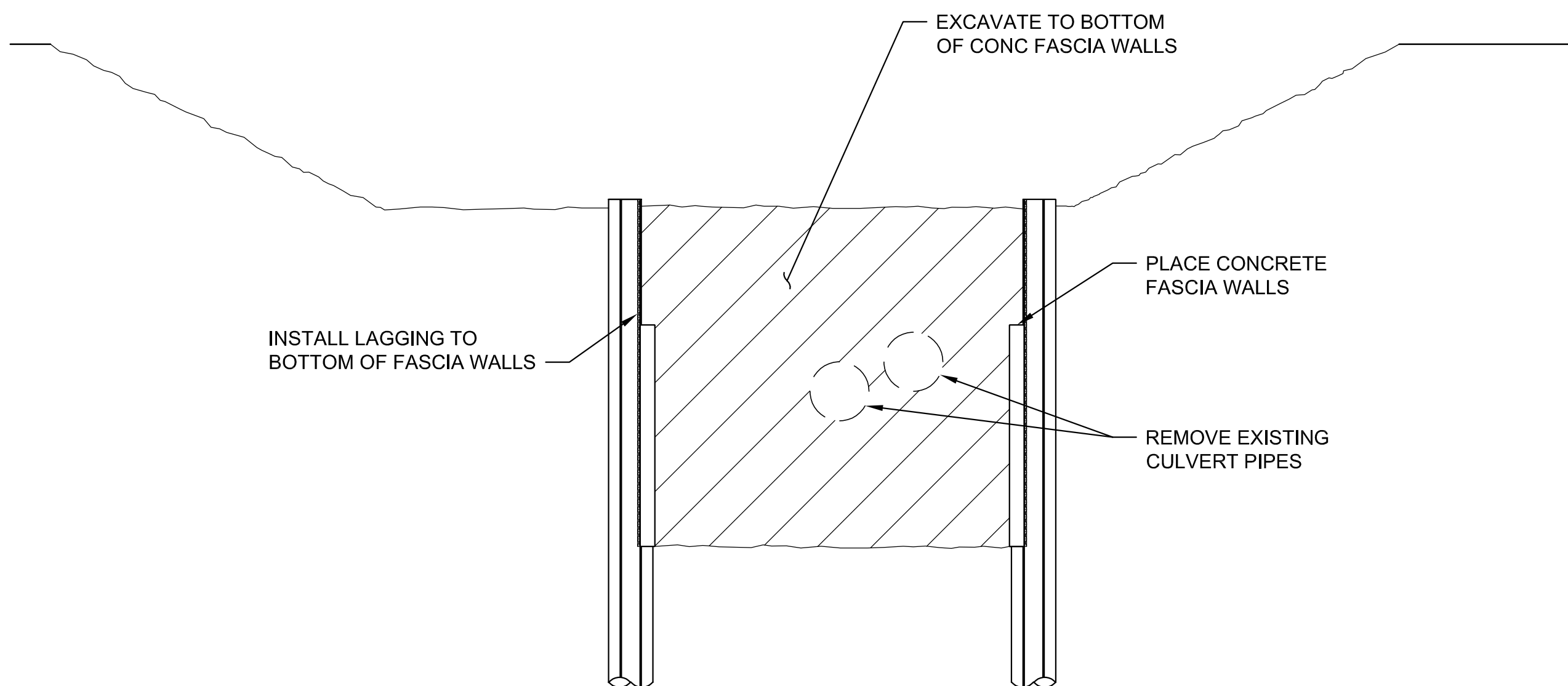

STEP 3

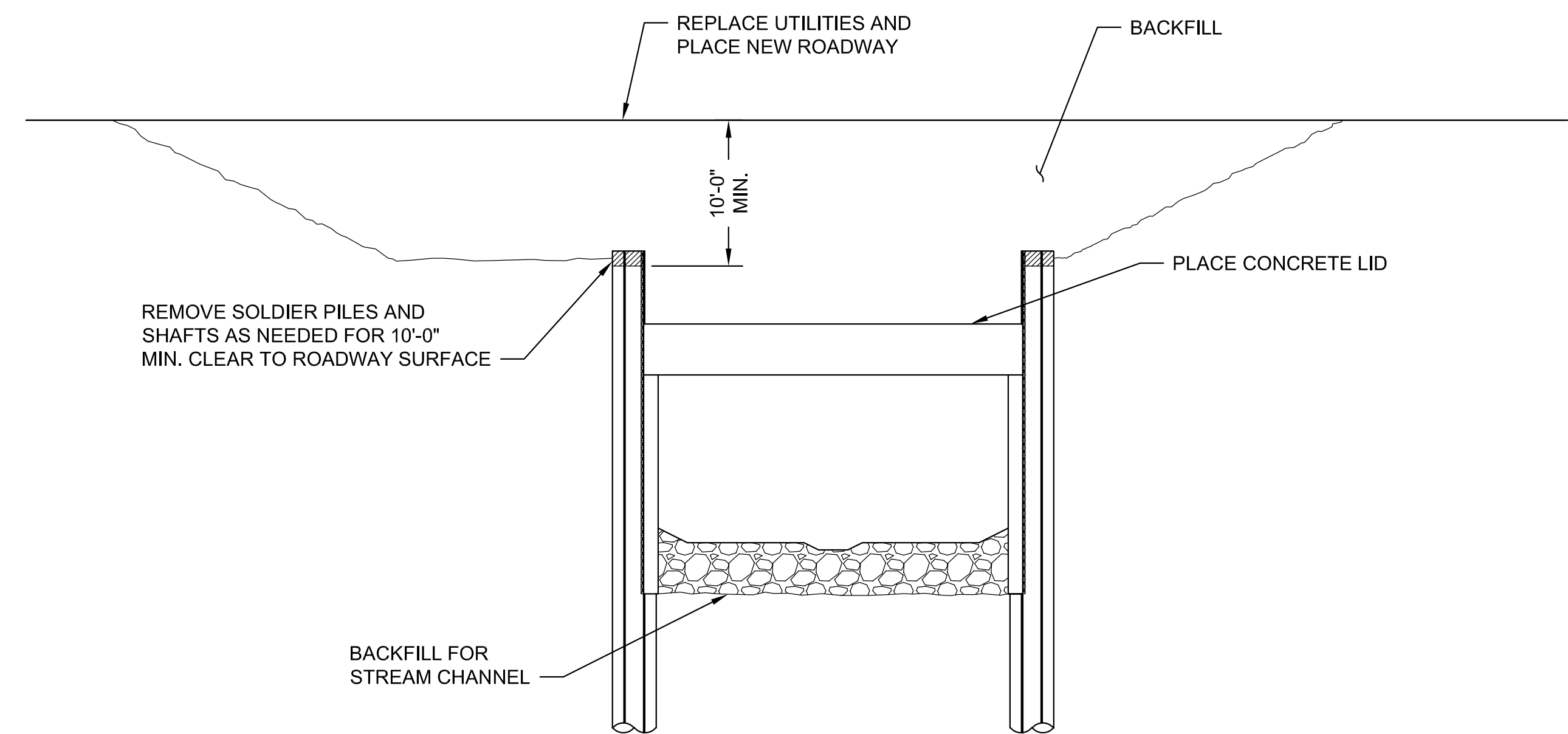

STEP 4

Mar 20, 2019 - 2:13pm
 thedgjin
 C:\pw_workdir\den003\ch2mhill_theagjin\d0456071\S-4.dwg

Description		Date	Initials
Drawn	Designed	Checked	Revisions
EM	IBM, VVV	ME	Revisions



17500 Midvale Avenue North
 Shoreline, WA 98133
 (206) 801-2700

**HIDDEN LAKE CULVERT
 REPLACEMENT
 30 PCT DESIGN - NOT FOR
 CONSTRUCTION**
 CULVERT CONSTRUCTION SEQUENCE



ONE INCH AT FULL SIZE
 IF NOT ONE INCH SCALE ACCORDINGLY

Project No. 18-06771-000

Sheet **S-4**

Sheet 16 Of 18



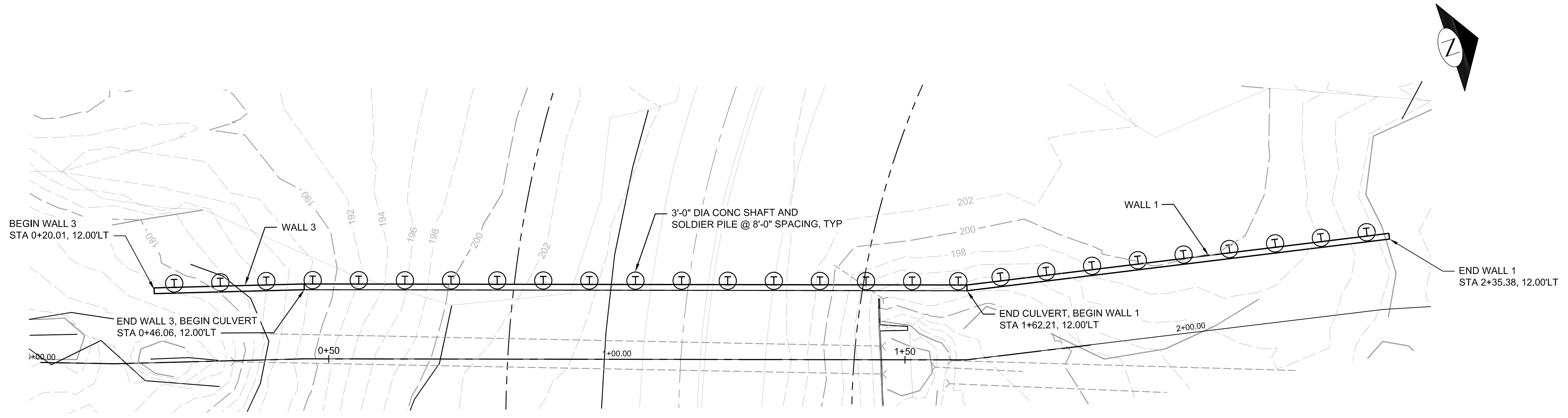

PLAN - WEST WALL

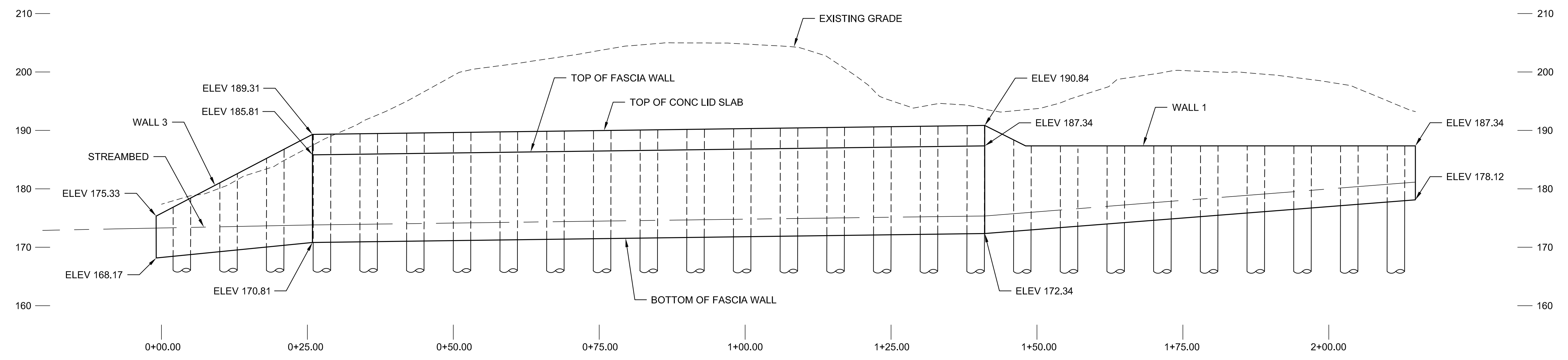

PROFILE - WEST WALL

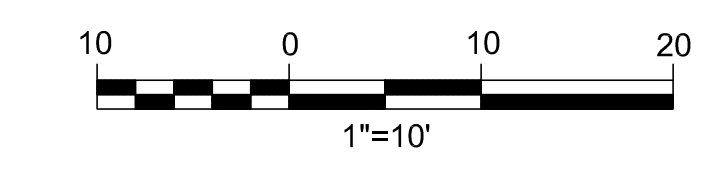

Initials		Date		Description	
EM					
IBM, VV					
ME					
Drawn	Designed	Checked	Revisions	Revisions	



17500 Midvale Avenue North
Shoreline, WA 98133
(206) 801-2700

**HIDDEN LAKE CULVERT
REPLACEMENT
30 PCT DESIGN - NOT FOR
CONSTRUCTION**
WEST RETAINING WALL PLAN AND PROFILE

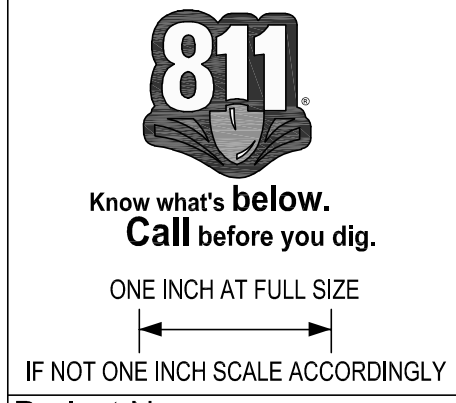

Project No. 18-06771-000

Sheet **S-5**

Sheet 17 Of 18

C:\pw_workdir\den003\ch2mhill_theadlin\0456071\S-5.dwg
ltheadlin
Mar 20, 2019 - 2:19pm

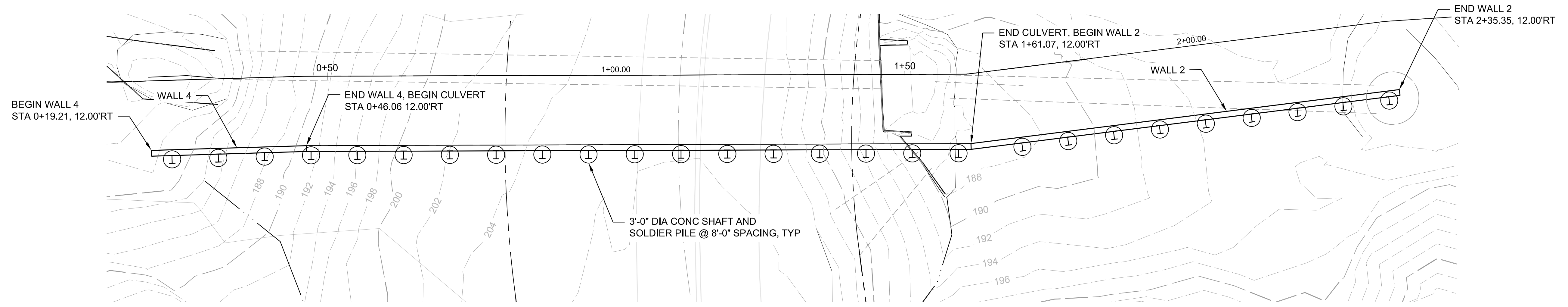

PLAN - EAST WALL

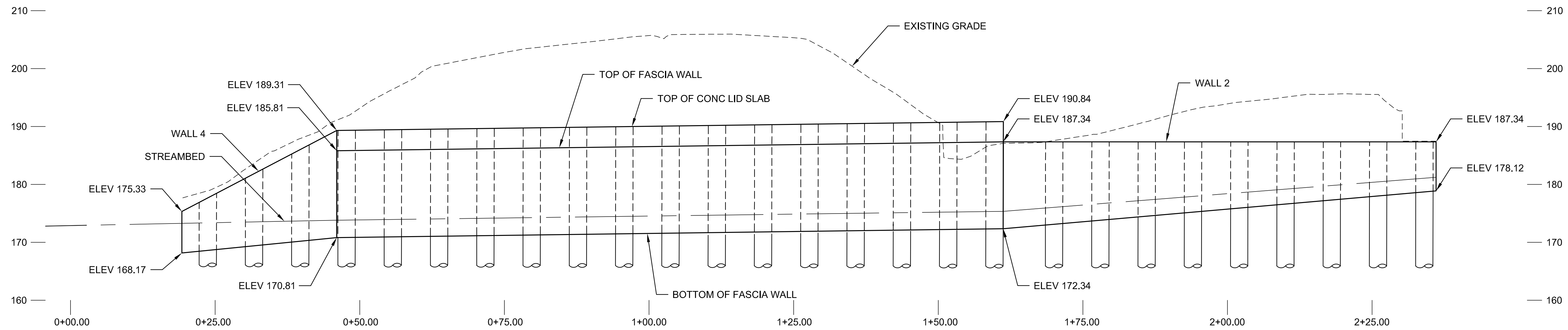

PROFILE - EAST WALL

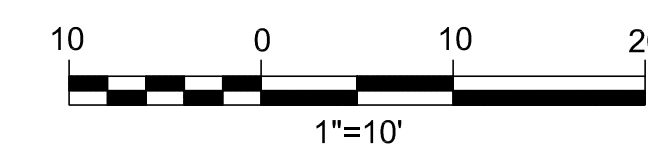

Description		Date
Initials	EM	
Drawn	Designed	Checked
Revisions	Revisions	Revisions



17500 Midvale Avenue North
Shoreline, WA 98133
(206) 801-2700

**HIDDEN LAKE CULVERT
REPLACEMENT
30 PCT DESIGN - NOT FOR
CONSTRUCTION**
EAST RETAINING WALL PLAN AND PROFILE



IF NOT ONE INCH SCALE ACCORDINGLY
Project No. 18-06771-000

Sheet **S-6**

Sheet 18 Of 18

C:\pw_workdir\den003\ch2mhill\thead\lin\d0456071\S-6.dwg
thead\lin
Mar 20, 2019 - 2:32pm



GENERAL NOTES

1. MAINTAIN A MINIMUM OF ONE ACCESS POINT FOR EACH PROPERTY WITHIN WORK AREA LIMITS.
2. ALL SIGNS ARE BLACK ON ORANGE UNLESS OTHERWISE DESIGNATED.
3. TRAVEL LANES SHALL HAVE A MINIMUM WIDTH OF 11 FEET.
4. WORK HOURS SHALL BE BETWEEN THE HOURS OF X AND X.

DETOUR PLAN

LEGEND

- FLAGGING STATION
- TEMPORARY SIGN LOCATION
- CHANNELIZING DEVICES
- TYPE 3 BARRICADE



Drawn	Checked	Revised	Reviewed

DRAFT



17500 Midvale Avenue North
Shoreline, WA 98133
(206) 801-2700

**HIDDEN LAKE DAM REMOVAL
30 PCT DESIGN - NOT FOR
CONSTRUCTION**

Know what's below.
Call before you dig.
ONE INCH AT FULL SIZE

(FOLLOW THE RECOMMENDED SCALE ACCORDINGLY)

Project No: 18-06771-000

Sheet **X-X** Of x