

# 2016

## ENGINEERING DEVELOPMENT MANUAL



### **Public Works Department**

City of Shoreline

17500 Midvale Avenue North

Shoreline, WA 98133

Page intentionally left blank.

# Contents

Contents .....	ii
FORWARD .....	i
DIVISION 1 – ADMINISTRATION .....	1
<b>Chapter 1. Introduction.....</b>	<b>2</b>
1.1. General Authority .....	2
1.2. Vesting.....	3
1.3. Revising the EDM .....	3
1.4. Copy of the EDM.....	3
1.5. Contact Information.....	4
<b>Chapter 2. Permits.....</b>	<b>6</b>
2.1. Site Development Permit.....	6
2.2. Right-of-way Permits.....	7
2.3. Public Utilities .....	9
2.4. Other Agencies .....	10
<b>Chapter 3. Permit Process .....</b>	<b>12</b>
3.1. Permit Process.....	12
3.2. Pre-application Meeting .....	14
3.3. Neighborhood Meeting .....	14
3.4. Permit Review .....	15
3.5. Plan Approval.....	15
3.6. Plan Revisions.....	15
3.7. Independent Review .....	15
3.8. Permit Issuance .....	15
3.9. Preconstruction Meeting .....	16
3.10. Permit Inspections.....	16
3.11. Final Project Approval.....	16
3.12. Permit Timing and Expiration .....	17

3.13.	Notification (Right-of-way).....	17
3.14.	Franchises, Electric and Communication Facilities .....	18
<b>Chapter 4.</b>	<b>Permit Submittals.....</b>	<b>20</b>
4.1.	Design Professionals .....	20
4.2.	Plans and Specifications.....	21
4.3.	Survey .....	21
4.4.	Site Assessment .....	22
4.5.	Surface Water Report .....	22
4.6.	Geotechnical Report .....	22
4.7.	Transportation Impact Analysis .....	23
4.8.	Traffic Control Plan.....	23
4.9.	Declaration of Covenant .....	23
4.10.	Easements .....	23
4.11.	Tracts.....	24
4.12.	Dedication.....	24
4.13.	Dewatering Plan.....	25
4.14.	Maintenance Plan .....	25
4.15.	Financial Guarantee.....	25
4.16.	Insurance.....	26
<b>Chapter 5.</b>	<b>Permit Fees .....</b>	<b>28</b>
5.1.	Fee-in-lieu of Frontage Improvements .....	28
5.2.	Independent Review .....	28
5.3.	Revisions to Issued Permits .....	28
5.4.	Traffic Impact Fees .....	28
<b>DIVISION 2 – RIGHT-OF-WAY .....</b>		<b>31</b>
<b>Chapter 6.</b>	<b>Standards.....</b>	<b>33</b>
6.1.	Companion Documents.....	33
6.2.	Deviation from Engineering Standards .....	34
<b>Chapter 7.</b>	<b>General Requirements .....</b>	<b>36</b>
7.1.	American Disabilities Act .....	36
7.2.	Low Impact Development .....	34
7.3.	Maintenance.....	36
7.4.	Tree Removal/Pruning.....	37

7.5.	Connectivity.....	37
7.6.	Underground Utilities.....	37
7.7.	Frontage Improvements .....	37
7.8.	Dedication of Right-of-Way.....	38
7.9.	Illumination .....	38
7.10.	Curbing.....	40
7.11.	Pavement Cut Moratorium.....	41
<b>Chapter 8.</b>	<b>Transportation Impact Analysis.....</b>	<b>43</b>
<b>Chapter 9.</b>	<b>Street Classification .....</b>	<b>44</b>
9.1.	Arterial Streets.....	44
9.2.	Non-Arterial (Local) Streets .....	44
9.3.	Alley.....	45
9.4.	Private Street.....	45
<b>Chapter 10.</b>	<b>Access Management.....</b>	<b>48</b>
10.1.	General.....	48
10.2.	Access Provision.....	50
<b>Chapter 11.</b>	<b>Access Design .....</b>	<b>52</b>
11.1.	General.....	52
11.2.	Access Width.....	52
11.3.	Access Clearance .....	53
11.4.	Access Approach .....	54
11.5.	Driveway.....	55
11.6.	Parking Lots .....	55
<b>Chapter 12.</b>	<b>Street Design .....</b>	<b>57</b>
12.1.	Reconstruction .....	57
12.2.	Widths.....	57
12.3.	Vertical Alignment .....	57
12.4.	Vertical Curve Criteria .....	58
12.5.	Horizontal Curve Criteria.....	59
12.6.	Street End.....	61
12.7.	Utility Locations .....	62
12.8.	Private Streets.....	64
12.9.	Dead End Streets.....	65

<b>Chapter 13.</b>	<b>Intersection Design.....</b>	<b>66</b>
13.1.	Alignment.....	66
13.2.	Spacing.....	66
13.3.	Design Vehicles .....	66
13.4.	Curb Radii.....	67
13.5.	Drainage.....	67
13.6.	Intersection Grades.....	67
13.7.	Pedestrian Treatments .....	68
13.8.	Clear Sight Triangle .....	70
13.9.	Pedestrian Sight Distance .....	73
<b>Chapter 14.</b>	<b>Nonmotorized Facilities .....</b>	<b>74</b>
14.1.	General.....	74
14.2.	Sidewalks .....	74
14.3.	Paved Paths.....	75
14.4.	Soft-Surface Paths.....	75
14.5.	Bicycle Facilities .....	76
<b>Chapter 15.</b>	<b>Roadside Features .....</b>	<b>78</b>
15.1.	Fixed Objects .....	78
15.2.	Landscaping.....	79
15.3.	Mailboxes .....	80
15.4.	Steps.....	80
15.5.	Railing.....	81
15.6.	Cut and Fill Slopes .....	82
15.7.	Guardrail.....	82
<b>Chapter 16.</b>	<b>Surface Treatment.....</b>	<b>84</b>
16.1.	General.....	84
16.2.	Asphalt Pavement Design .....	84
16.3.	Pavement Widening.....	85
<b>Chapter 17.</b>	<b>Traffic Control Devices .....</b>	<b>86</b>
17.1.	Traffic Signals.....	86

DIVISION 3 – SURFACE WATER .....	85
Chapter 18.    Surface Water Standards.....	87
Chapter 19.    Stormwater Manual Modifications.....	89
Chapter 20.    General Requirements.....	97
20.1.    Licensed Professionals.....	97
20.2.    Grading.....	97
20.3.    Special Drainage Areas.....	97
20.4.    Water Quality Restrictions.....	98
20.5.    Separated Runoff.....	98
20.6.    Backflow Prevention.....	98
20.7.    Sump Pumps.....	98
20.8.    Footing Drains.....	98
20.9.    Catch Basin Medallions.....	99
20.10.    Maintenance Access.....	99
20.11.    Offsite Drainage Improvements.....	99
20.12.    Watercourses.....	99
20.13.    Stormwater Facility Operation.....	100
20.14.    Subdivisions.....	100
20.15.    Phased Projects.....	100
20.16.    Protect Vegetation Post Construction.....	101
Chapter 21.    Infiltration.....	102
21.1.    Soils and Subsurface Investigation.....	102
21.2.    Prohibitions.....	105
21.3.    Horizontal Setbacks.....	106
21.4.    Vertical Setbacks.....	108
21.5.    Verification Testing.....	108
Chapter 22    Surface Water Project Classifications.....	110
22.1.    Small Impact Projects.....	110
22.2.    Medium Impact Projects.....	110
22.3.    Large Impact Projects.....	111

Chapter 23.	Site Development Plan.....	114
Chapter 24.	Stormwater Pollution Prevention Plan (SWPPP).....	118
24.1.	SWPPP Requirements.....	118
24.2.	Rainy Season.....	119
24.3.	Stop Work.....	121
Chapter 25.	Flood Control.....	122
Chapter 26.	Conveyance	
System.....		124
26.1.	Pipe Specifications.....	124
26.2.	Drop Structures.....	128
26.3.	Rockerries/Retaining Walls Crossing.....	128
26.4.	Ditch Modifications.....	128
DIVISION 4 – CONSTRUCTION AND INSPECTION .....		132
Chapter 27.	Construction.....	132
27.1.	Standards.....	132
27.2.	General.....	132
27.3.	Temporary Traffic Control.....	135
27.4.	Staking.....	136
27.5.	Trenches.....	137
27.6.	Traffic Signal Loops.....	138
27.7.	Sidewalks.....	138
27.8.	Landscaping.....	139
27.9.	Grading.....	140
27.10.	Curb, Gutter, Access Approach.....	141
27.11.	Pavement Restoration.....	142
Chapter 28	Inspection.....	147
28.1.	Authority and Duties of Inspectors.....	147
28.2.	Requirements.....	148



## TABLES

Table 1. Contact Information.....	4
Table 2. Site Development Permit Activities .....	6
Table 3. Right-of-way Use Permit Activities .....	7
Table 4. Right-of-Way Site Permit Activities.....	9
Table 5. Permit Process Outline .....	12
Table 6. Right-of-Way-Maintenance Responsibilities .....	36
Table 7. Pedestrian Facility Light Levels.....	39
Table 8. Street Classification Characteristics (typical).....	46
Table 9. Access Widths.....	53
Table 10. Typical Lane Widths.....	57
Table 11. Maximum Profile Grade.....	58
Table 12. Vertical Curve – Minimum Stopping Sight Distance.....	59
Table 13. Horizontal Curve Design.....	60
Table 14. Underground Utility Locations.....	62
Table 1567. Private Street Dimensions.....	65
Table 1678. Typical Curb Radii Design Values.....	67
Table 1778. Standard Lateral Clearances.....	78
Table 18. Standard Vertical Clearances.....	78
Table 19. Large Impact Projects Soil and Subsurface Investigation Requirements.....	105
Table 20. Pipe Materials, Cover and Bedding.....	124
Table 21. Conveyance System Specifications.....	124
Table 22. Conveyance System Vertical Clearances.....	127

## FIGURES

Figure 1. Clear Sight Triangle – Residential Driveway.....	72
Figure 2. Clear Sight Triangle – Uncontrolled Crossing Intersection.....	72
Figure 3. Clear Sight Triangle – Yield and T Intersections.....	73
Figure 4. Tree Protection – Right-of-way.....	134
Figure 5. Tree Installation – Right-of-way.....	141

## APPENDICES

APPENDIX A –	ACRONYMS AND DEFINITIONS
APPENDIX B –	SURVEY CRITERIA
APPENDIX C –	SURFACE WATER REPORT GUIDELINES
APPENDIX D –	GEOTECHNICAL REPORT GUIDELINES

- APPENDIX E - TRANSPORTATION IMPACT ANALYSIS REPORT GUIDELINES
- APPENDIX F - STREET MATRIX
- APPENDIX G - RIGHT-OF-WAY STREET TREE LIST
- APPENDIX H - PILOT INFILTRATION TEST
- APPENDIX I - RECORD DRAWING CRITERIA
- APPENDIX J - STREET LIGHTING LEVELS CRITERIA CRITERIA

Page intentionally left blank.



# FOREWORD

This Engineering Development Manual provides information to the development community to help with the processes, administration, engineering, and inspection that apply to private development within Shoreline. Land Use codes related to development can be found in SMC 20 Development Code.

This manual has four divisions:

**Division 1: Administration** contains information related to permits.

**Division 2: Right-of-way** presents standards and other information related to development within the right-of-way.

**Division 3: Surface Water** contains surface water policies, as well as design standards.

**Division 4: Construction and Inspection** provides the basics regarding construction and inspection in the City right-of-way.

The appendices contain information which supplements the four divisions.

Appendix A	Glossary
Appendix B	Survey Criteria
Appendix C	Surface Water Report Guidelines
Appendix D	Geotechnical Report Guidelines
Appendix E	Transportation Impact Analysis Report Guidelines
Appendix F	Street Matrix
Appendix G	Right-of-Way Street Tree List
Appendix H	Pilot Infiltration Test
Appendix I	Record Drawing Criteria

Page intentionally left blank.

# DIVISION 1 – ADMINISTRATION

## Chapter 1. Introduction

### 1.1. General Authority

Shoreline Municipal Code 20.70.020 authorizes creation of the Engineering Development Manual (EDM).

This manual addresses permitting and engineering requirements for site and right-of-way work related to development within the City of Shoreline. While this manual is geared toward the developer and the design/development engineer, it is intended to provide information to a wide group of users.

The manual sets forth minimum engineering criteria and specifications, and supplements the Shoreline Municipal Code. It does not replace the code. These standards do not substitute for engineering design, nor are these standards intended to limit innovative design where equal performance in value, safety, and maintenance can be demonstrated.

The Director may substitute more stringent design standards and specifications where special conditions warrant.

The City's website provides access to the Engineering Development Manual, the Shoreline Municipal Code (SMC), information handouts, permit applications, and other guidance documents. SMC 20 contains the Development Code.

City's website: <http://www.shorelinewa.gov>

Engineering Development Manual: <http://www.shorelinewa.gov/home/showdocument?id=11018>

Shoreline Municipal Code: <http://www.codepublishing.com/wa/shoreline/>

Shoreline Development Code:

<http://www.codepublishing.com/wa/shoreline/html/Shoreline20/Shoreline20.html>

Development Handouts and Permit Applications:

<http://www.shorelinewa.gov/government/departments/planning-community-development/permit-and-development-information/development-handouts>



## 1.2. Vesting

A project is vested under the codes in place on the date when the permit application is determined to be complete by the City. Refer to Submittal Checklists for guidance on complete applications.

The City periodically reviews and revises the EDM. In the case that a code or standard has been revised more recently than the update cycle for this manual, the most current code or standard supersedes the information provided in this manual.

A permit that has been canceled is no longer vested. If the Applicant wishes to continue with the project, a new application must be submitted and the project will be subject to the regulations in place at the time the new complete application is received by the City.

The edition of this manual that applies to a particular project is the edition in effect when the proposed project is vested. If a newer version of the EDM is published after a project is vested, either the newer version of the EDM in its entirety or the older version in its entirety may be used.

## 1.3. Revising the EDM

Requests for revisions to the content of the EDM may be submitted to the Public Works Department or online at <http://www.shorelinewa.gov/government/departments/public-works/capital-improvement-plan/engineering-standards>.

At a minimum the request should include the name and contact information of the proponent, a brief description of the reason for the revision, and a copy of the text or drawing proposed for revision.

## 1.4. Copy of the EDM

The Engineering Development Manual is available online at <http://www.shorelinewa.gov/home/showdocument?id=11018>

The EDM is also available on compact disc for a fee. For a copy of the EDM, please contact the Public Works Department.

## 1.5. Contact Information

The contact information in Table 1 is provided as assistance during project planning and development and is not a comprehensive list of contacts. Also refer to the Community Directory, available through the City of Shoreline website: <http://www.shorelinewa.gov/community/community-directory>.

**Table 1. Contact Information**

<p>Planning and Community Development          17500 Midvale Avenue N          Shoreline, WA 98133-4905  <a href="http://www.shorelinewa.gov/government/departments/planning-community-development">http://www.shorelinewa.gov/government/departments/planning-community-development</a>          (206) 801-2500</p>	<p>Public Works Department          17500 Midvale Avenue N          Shoreline, WA 98133-4905  <a href="http://www.shorelinewa.gov/government/departments/public-works">http://www.shorelinewa.gov/government/departments/public-works</a>          (206) 801-2400</p>
<p>Shoreline Fire Department          17525 Aurora Avenue N          Shoreline, WA 98133  <a href="http://www.shorelinefire.com">http://www.shorelinefire.com</a>          (206) 533-6500</p>	<p>Shoreline Police Department          1206 N 185th Street          Shoreline, WA 98133  <a href="http://www.shorelinewa.gov/government/departments/police-department">http://www.shorelinewa.gov/government/departments/police-department</a>          (206) 801-2710</p>
<p>Customer Response Team          17500 Midvale Avenue N          Shoreline, WA 98133-4905  <a href="http://www.shorelinewa.gov/community/customer-response-team">http://www.shorelinewa.gov/community/customer-response-team</a>          (206) 801-2700</p>	
<p>Sanitary Sewer Purveyor: Ronald Wastewater District          17505 Linden Avenue N          Shoreline, WA 98133  <a href="http://www.ronaldwastewater.org">http://www.ronaldwastewater.org</a>          (206) 546-2494</p>	<p>Solid Waste Purveyor: Recology CleanScapes, Inc.          117 S Main Street, Suite 300          Seattle, WA 98104  <a href="http://www.cleanscapes.com/shoreline.html">http://www.cleanscapes.com/shoreline.html</a>          Phone: (206) 763-4444</p>
<p>Water Purveyor: North City Water District          1519 NE 177th Street          Shoreline, WA 98155  <a href="http://www.shorelinewater.org">http://www.shorelinewater.org</a></p>	<p>Water Purveyor: Seattle Public Utilities          700 5th Avenue, Suite 4900          Seattle, WA 98104  <a href="http://www.seattle.gov/util/services/">http://www.seattle.gov/util/services/</a></p>

(206) 362-8100	Customer Service: (206) 684-3000 SPU Water Certificate: (206) 684-5795
Water and Sewer Purveyor: The Highlands (206) 362-2100	Natural Gas Purveyor: Puget Sound Energy 10885 NE 4th Street, P.O. Box 97034 Bellevue, WA 98009-9734 <a href="http://www.pse.com/Pages/default.aspx">http://www.pse.com/Pages/default.aspx</a> 1-888-225-5773
Electric Purveyor: Seattle City Light 700 5th Avenue, Suite 3200 Seattle, WA 98104 <a href="http://www.seattle.gov/light">http://www.seattle.gov/light</a> (206) 684-3000	Electrical Permits: State of Washington Department of Labor and Industries <a href="http://www.lni.wa.gov/TradesLicensing/Electrical/default.asp">http://www.lni.wa.gov/TradesLicensing/Electrical/default.asp</a> (425) 996-1496

## Chapter 2. Permits

The information in this chapter summarizes the requirements in the City of Shoreline Municipal Code. If there are any conflicts, the Municipal code shall prevail. Prior to beginning a residential, commercial, or industrial development, or a project requiring construction of public infrastructure within the City, the proponent must prepare and submit a complete application, including permit application, plans, and specifications to the Department of Planning and Community Development for review and approval.

### 2.1. Site Development Permit

Site development can be permitted under a Site Development Permit or as part of a Building Permit. Examples of work that can trigger a separate Site Development Permit are listed in Table 2. Site Development Permit Activities.

**Table 2. Site Development Permit Activities**

Paving, grading/clearing (land disturbance), tree removal, on-site utility installation, stormwater facilities, walkways, striping, wheel stops or curbing for parking and circulation, landscaping, or restoration (SMC Chapter 20.20.046);  
The construction of two or more detached single-family dwelling units on a single parcel (SMC Chapter 20.30.315);  
Site improvements associated with short and formal subdivisions (SMC Chapter 20.30.315);  
The construction of two or more nonresidential or multifamily structures on a single parcel (SMC Chapter 20.30.315); or  
Land disturbing activities that impact drainage defined by the Stormwater Manual as Minimum Requirements #1-9.

The following activities are usually exempt from Site Development Permit, unless located in a critical area or critical area buffer:

- Excavation for a structure approved by a building permit;
- Excavation for cemetery graves;
- Excavation at refuse disposal sites approved under other regulations;
- Excavation for wells or utility trenches; and

Excavation for exploration performed under the direction of a registered design professional.

## 2.2. Right-of-way Permits

City rights-of-way shall not be privately improved or used for access or other purposes unless a permit has been issued for such use. Issued permits do not convey any vested right or ownership interest in any City right-of-way. (SMC Chapter 12.15)

Right-of-way Use Permit Right-of-Way Use Permits are issued for short-term activities in the right-of-way and temporary alteration of the right-of-way. Activities that trigger a Right-of-way Use Permit are included in Table 3. Right-of-Way Use Permit Activities.

**Table 3. Right-of-way Use Permit Activities**

1. Temporary complete or partial closures of traffic lanes or sidewalks;
2. Boring, jacking, or pushing;
3. Construction or painting adjacent to the right-of-way that may physically impact the right-of-way;
4. Construction related to the installation of culverts, curb cuts, handicap ramps, sidewalks and driveway approaches;
5. Drainage facilities;
6. Installation of landscaping;
7. Paving;
8. Street trenching;
9. Temporary construction devices, such as scaffolding, barricades, walls, elevators, cranes, pedestrian walkways, etc.;
10. House moves, special usage of the street and/or public right-of-way to move houses or other oversize and overweight, materials and structures at specific times and locations;
11. Street runs, or races held on public streets and sidewalks on specific routes, parades and processions;
12. Assemblies, fairs, carnivals, shows, exhibitions, or large gatherings of people that may use or obstruct the right-of-way with people, vehicles, and signs that may produce noise;
13. Commercial filming or videotaping except that associated with news reporting;
14. Parking spaces temporary dedicated for private use.

The following activities usually are exempt from a Right-of-way Use Permit:

Utility facilities placed in the right-of-way under the authority of a franchised utility in good standing may be exempt from the requirement to obtain a use permit if the activity is exempted under Chapter 12.15.170 SMC or is a minor or blanket activity specified in Chapter 12.15.180 SMC;

City public works projects;

Utilities in the right-of-way under the authority of a franchise agreement or site permit for relocation or conversion of facilities because of City initiated construction projects. This provision only applies to work that would not otherwise have been done by the utility; and

The ordinary maintenance of landscaping in the right-of-way. Blockage of the right-of-way associated with ordinary maintenance of landscaping requires a use permit.

Right-of-way Site Permit A Right-of-way Site Permit allows private improvements or private long-term use of public right-of-way. A Right-of-way Site Permit is not required for use of right-of-way that is expressly allowed by the Development Code. A Right-of-way Use permit may be required in conjunction with a right-of-way site permit to construct or install structures and/or amenities associated with the use. For specific information on Right-of-Way Site Permits see SMC 12.15.030(C).

Site permits may be granted for a period of up to five years. In addition to a permit fee, for some specific uses the Permittee may be assessed an annual fee for the length of the permit. The annual fee is calculated using the square feet of right-of-way proposed for leasing and multiplying it by 10 percent of the square foot dollar value of the abutting property.

Upon termination of a Right-of-way Site Permit, if the permit is not renewed, the Permittee shall remove any improvements constructed in the right-of-way and restore the area to its original condition or better. Removal of improvements in the right-of-way could trigger the requirement of a Right-of-way Use Permit.

All right-of-way site permits require approval by the Public Works Director.

Improvements in the right-of-way shall meet the technical requirements presented in Division 2. Right-of-way encroachments that compromise public safety will not be allowed. Examples of activities requiring right-of-way site permit are shown in Table 4. Right-of-way Site Permit Activities.

**Table 4. Right-of-Way Site Permit Activities**

Accessory uses permitted to the adjacent property such as parking, displays, and signage, provided the proposed use is not required to meet city development standards for any private property development;

Air rights;

Bus shelters/stops;

Fences, retaining walls, terracing, and similar structures;

Litter and recycle receptacles placed by private parties;

Special and unique structures such as benches, fountains, clocks, flagpoles, kiosks banners, street furniture, decorations, bicycles racks, private planters, or any other obstruction to be placed in the right-of-way by an entity other than the city.

Sales structures, including sidewalk cafes, telephone booths, or the usage of the right-of-way for the sales of flowers, beverages, newspaper, or other items;

Underground rights;

Utility facilities not exempt under a franchised agreement with the City.

The following activities are exempt from the Right-of-Way Site Permit:

Utility facilities placed in the right-of-way under the authority of a franchised utility.

If the adjacent zone expressly permits use of the right-of-way, that use may be approved for an indefinite duration and is exempt from compensation. For example: The North City Business District allows awnings on buildings to project into the right-of-way. The awnings are expressly permitted in the zoning code and do not require a right-of-way site permit.

### 2.3. Public Utilities

Depending on the type of work and the standing of the utility, a permit may be required for a utility to work in the right-of-way. Refer to SMC Chapter 12.15.180 for more information.

### 2.4. Other Agencies

Utility and similar districts within the City are separate entities that are not owned or operated by the City (water districts, sewer district, fire district, and other utility providers). It is the Applicant's

responsibility to obtain permits from other agencies. Prior to issuing City of Shoreline permit(s), verification that the Applicant has obtained other required permits may be required.

Seattle Public Utilities, Seattle City Light, North City Water District, and Ronald Wastewater District are entities separate from the City of Shoreline. In order to ensure coordination between these utilities, the, proposed locations of water, sewer, gas, and power in the right-of-way must be approved by each provider as part of the permit review process.

The permit plans must show the right-of-way installation locations as approved by each provider. Each utility only needs to approve the proposed locations. Approval should consist of signature/initials with phone number and date from a representative of each provider on a civil plan showing the proposed utility location.

Permits from other agencies may include:

Electrical permits: Washington State Department of Labor and Industries, (425) 990-1430.

Electrical service permit: Seattle City Light, (206) 684-3000.

Propane tanks: Shoreline Fire Department, (206) 533-6500.

Sewer connection services and related information: Ronald Wastewater District, (206) 546-2494 or The Highlands, (206) 362-2100.

Water connection services and related information: Seattle Public Utilities (generally sites west of I-5), (206) 684-5800 or North City Water District (generally sites east of I-5), (206) 362-8100.

Washington Department of Fish and Wildlife

Any work below the Ordinary High Water Mark (OHWM) of surface waters including intermittent streams (work that uses, diverts, obstructs or changes natural flow or bed of State waters);

Any work that uses, diverts, obstructs, or changes the natural flow or bed of any of the salt or fresh waters of state requires a Hydraulic Project Approval (HPA) permit. Download the application for an individual permit, called a Joint Aquatic Resource Permit Application (JARPA), from the Department of Fish and Wildlife website.



## Department of Ecology

An NPDES (National Pollutant Discharge Elimination System) Construction Permit Notice of Intent is required from the Washington State Department of Ecology for all soil disturbing activities (including clearing, grading, and/or excavation) where one or more acres will be disturbed, and stormwater will be directly discharged to a receiving water (e.g., wetlands, creeks, unnamed creeks, rivers, marine waters, ditches, estuaries) or to storm drains that discharge to a receiving water. If all storm water is retained on-site and cannot enter surface waters of the state under any condition, the project may not trigger a permit.

Coastal Zone Management Certification (CZM) is issued by the federal permitting agency or state DOE. Army Corps of Engineers

Water Quality Certification (401) ensures that limits placed in a permit on the quantity and concentration of pollutants discharged are not exceeded.

Activities that may affect endangered species should be reviewed for permits under Section 404 of the Clean Water Act and Section 10 of the Rivers and Harbors Act. The Army Corps of Engineers coordinates with the NOAA Fisheries and U.S. Department of Fish and Wildlife to ensure Endangered Species Act consistency.

U.S. Coast Guard and WA State Department of Natural Resources are also involved in certain projects involving impacts (such as a bridge) over or adjacent to navigable waters (Class 1 streams).

Federal Emergency Management Agency (FEMA) administers programs related to flood protection.

## Chapter 3. Permit Process

This chapter describes how the Applicant and the City work together during the permit process. Each permit application submitted to Planning and Community Development is assigned a project manager. The project manager or Planning and Community Development permit services can provide process information related to a specific permit. Contact Planning and Community Development for more information.

### 3.1. Permit Process

Table 5. Permit Process Outline is a general outline of the application review process and may be adjusted to meet particular project circumstances. Not all of the steps listed below are required for all permits. Contact the Planning and Community Development for an explanation of the steps applicable to a certain permit application. Description of various elements of the permit process follows the table.

**Table 5. Permit Process Outline**

Activity	Responsible Party
I. Schedule a pre-application meeting when required by SMC 20.30.080 (or when desired)	Applicant
II. Project Proposal A. Prepare studies and reports B. Prepare Project Plans C. Conduct Neighborhood Meeting when required by SMC 20.30.090	Applicant
III. Application(s) Submittal Only applications meeting the procedural submittal requirements will be processed (Refer to the appropriate permit submittal checklist for required submittal information) <ul style="list-style-type: none"> <li>• Application Form</li> <li>• Project Plans</li> <li>• Reports or other submittal information</li> <li>• Application fee</li> </ul>	Applicant

Activity	Responsible Party
<p>IV. Review</p> <ul style="list-style-type: none"> <li>Assign a project manager (PM)</li> <li>Determine completeness</li> <li>Coordinate reviews (for example Fire Department, Public Works, and Building and Inspection Team)</li> <li>Approve permit or send a comment letter to designated contact. Redlined plans may accompany the comment letter</li> </ul>	City
<p>V. Revision and Re-submittal</p> <ul style="list-style-type: none"> <li>A. Revise plans per the City's comments</li> <li>B. Submit revised plans and provide revised supporting documents</li> <li>C. Submit redlined plans that were provided by the City</li> </ul>	Applicant
<p>VI. Revision and Re-submittal Review</p> <ul style="list-style-type: none"> <li>A. Coordinate plan review and verify that all comments have been satisfactorily addressed</li> <li>B. Approve permit or send a comment letter to designated contact. Redlined plans may accompany the comment letter</li> </ul>	City
<p>VII. Notification</p> <p>Notify Applicant's designated contact regarding outstanding items needed for issuance. Before the permit is issued, all requirements for issuance must be met. These may include proof of insurance, financial guarantee, covenants, easements, payment of fees, and/or dedications. When all conditions for issuance are met, and the permit(s) is ready to issue, a representative from Planning and Community Development will notify the designated contact person that the permit is ready.</p> <p>At this time, Planning and Community Development will notify the Applicant of fees owed.</p>	City
<p>VIII. Obtain Permit</p> <ul style="list-style-type: none"> <li>A. Provide outstanding items</li> <li>B. Pay any remaining fees and post required financial guarantees</li> <li>C. Receive the permit</li> </ul>	Applicant
<p>IX. Pre-Construction Meetings</p> <p>Schedule a pre-construction meeting. Construction may not begin before having a pre-construction meeting.</p>	Permittee

Activity	Responsible Party
X. Construction A. Complete all activities identified in the approved plans to City of Shoreline satisfaction B. Notify the City Inspector assigned to the project when elements are ready for inspection	Permittee
XI. Perform all required inspections including final inspection XII. Release Performance Financial Guarantee	City
XIII. Close-out Provide maintenance/monitoring financial guarantee Provide as-constructed/record drawings when required	Permittee
XIV. Cancel expired permit applications when applicable. See 3.12, Permit Timing and Expiration	City
XV. Permit Extension Request (Optional)	Permittee

### 3.2. Pre-application Meeting

Not all projects require a pre-application meeting, but many projects benefit from this service. A pre-application meeting allows the potential Applicant, City representatives, and some external agencies an opportunity to discuss a proposed project before a permit application is submitted. The pre-application meeting provides the project proponent information regarding permits, permit processes, codes, and standards that apply to the proposed project.

The meeting is scheduled at the time the Applicant submits an application for the meeting. Please refer to the Pre-Application Meetings handout that is available in Planning and Community Development or online at: <http://www.shorelinewa.gov/home/showdocument?id=2432>.

### 3.3. Neighborhood Meeting

When required by SMC 20.30.090, the Applicant holds a neighborhood meeting, inviting all property owners within 500 feet of the project site. A summary of the meeting and list of attendees is submitted with the application materials.

### 3.4. Permit Review

The permit review process is a partnership between the Applicant and City representatives. Planning and Community Development will review permit submittals or coordinate review with other departments and/or external agencies for compliance with applicable standards following the general outline in Table 5, Permit Process Outline.

The City reviews permits concurrently for projects having a building or site development permit and a Right-of-way permit. Generally, the City issues the right-of-way permit with its associated building permit or site development permit.

### 3.5. Plan Approval

Plan approval does not relieve the Applicant, the Applicant's engineer, or the contractor from the responsibility for ensuring that all facilities are safe and that calculations, plans, specifications, construction drawings and record drawings with as-constructed information are in compliance with accepted engineering practices, this manual, and applicable federal, state, and local laws and codes.

### 3.6. Plan Revisions

To help with plan review, the revisions should be called out on the plans using "clouds" or some other indicator. The revised plan(s) should include the revision number and date particular to that plan set.

The engineer of record must stamp, sign, and date revisions to the design prepared under the engineer's authority.

### 3.7. Independent Review

Depending on the site conditions and design complexity, the City may determine that reports, such as geotechnical, stream or wetland reports submitted to the City may require independent (third party) review.

### 3.8. Permit Issuance

Before a permit is issued, all requirements for issuance must be met. These may include proof of liability insurance, financial guarantees, recorded covenants, easements or dedications, and/or payment of any outstanding fees. When all conditions for issuance are met, and the permit is ready to issue, a

representative from Planning and Community Development will notify the designated contact person that the permit is ready, and what fees are owed.

### 3.9. Pre-construction Meeting

Many projects may require a pre-construction meeting. Depending on the project scope, more than one meeting may be required. Construction may begin only **after** the required pre-construction meeting(s). The Permittee is responsible for scheduling the pre-construction meeting(s). Directions for scheduling a pre-construction meeting(s) are found on the issued permit(s).

### 3.10. Permit Inspections

For more information on inspections, refer to Chapter 29, Inspection.

Inspections on-site are performed by representatives of Planning and Community Development.

Work within the right-of-way is subject to inspection by a Public Works Right-of-way Inspector.

Inspections are usually performed Monday through Friday, from 8:00 a.m. to 4:00 p.m.

Some projects may require special inspections performed by pre-approved third parties.

### 3.11. Final Project Approval

**Fees.** If, during construction, the number of estimated inspections is exceeded, or if revisions to approved plans have been submitted for review, additional fees may apply. All inspection, plan revision review, and other fees due the City must be paid prior to final project approval.

Permanent Stabilization All disturbed areas must have permanent stabilization in place and functioning before final project approval.

Financial Guarantee Refer to Chapter 4, Permit Submittals for more information on Financial Guarantees.

Declaration of Covenant Prior to the final project approval, executed covenants that have been recorded at the time of permitting are verified to be in conformance with the constructed items.

Record Drawings Record drawings must be provided for private infrastructure that connects to the City's infrastructure, for public facilities, and for right-of-way work. Refer to Appendix I – Record Drawings for more information.

Inspections All inspections must be completed. Upon completion of all site or right-of-way work and associated conditions approved under a permit, the Permittee shall request a final inspection.

**Work Completion.** The permit process is complete upon final inspection approval by the City.

### 3.12. Permit Timing and Expiration

The following provides general guidelines regarding application and permit expiration. For specific information contact the project manager or Planning and Community Development.

#### Issuance Notification.

Following plan approval, a representative of Planning and Community Development notifies the contact indicated on the permit application that the permit is ready to issue and of any fees owed.

Following notification, the Applicant has six months to obtain the permit. A permit held for more than six months without issuance and with no contact from the Applicant is subject to cancellation.

#### Issued Permit.

Permits are valid for the periods specified by ordinance.

If the proposed work cannot be completed within the time covered by the permit, the City may grant an extension. The Applicant must submit a written extension request to Permit Services.

The City may assess additional fees for permit renewal and inspection.

### 3.13. Notification (Right-of-way)

When required, at the time of application for a right-of-way permit, the Applicant shall notify all public and private utility entities known to be using or proposing to use the same right-of-way of the proposed timing of such construction. Within seven days of receiving this notification,

any such entity notified may request a delay of the proposed construction to coordinate other right-of-way construction with the Applicant (SMC Chapter 12.15).

Notification is required for any project that has the potential to disturb encroachments into the right-of-way. Public Works will notify and work with abutting property owner(s) when there are encroachments that adversely affect installation of right-of-way improvements.

### 3.14. Franchises, Electric and Communication Facilities

In addition to a specific franchise agreement, requirements for the construction and usage of the right-of-way by utility providers are located in SMC Chapter 12.25 Right-of-Way Franchises, and SMC Chapter 13.20 Electric and Communication Facilities.



Page intentionally left blank.

## Chapter 4. Permit Submittals

Depending on particular project elements, the City may request submittals in addition to those described. To be considered for continued processing, all applications must be complete. Not all projects are required to submit all of the information listed below. Additional information is available on permits and development on the City's website:

<http://www.shorelinewa.gov/government/departments/planning-community-development/permit-and-development-information/development-handouts>.

### 4.1. Design Professionals

**Engineering** State law requires that certain work be performed by or under the direction of a professional licensed to practice in Washington State including engineering and land surveying.

**Right-of-way.** Nearly all right-of-way design, except simple activities such as installation of a driveway apron, requires design by a Washington State licensed civil engineer.

**Stormwater.** Design of treatment facilities, flow control facilities (detention ponds or infiltration basins), structural source control BMPs, or drainage conveyance systems shall be prepared by or under the direction of a licensed engineer. Construction Stormwater Pollution Prevention Plans (SWPPPs) that involve engineering calculations must also be prepared by or under the direction of a licensed engineer.

**Surveyor.** Activities requiring a surveyor include:

Nearly all right-of-way work. The survey work includes setting right-of-way lines, locating conveyance systems and setting elevations, locating curbs and setting curb elevations, locating drainage improvements and recording elevations, and providing as-constructed information on record drawings.

Construction of treatment facilities or flow control facilities (detention ponds or infiltration basins), structural source control Best Management Practices (BMPs), or drainage conveyance systems to set locations and elevations.

Cuts on slopes steeper than 15 percent require a professional surveyor to set the slope stakes to confirm top and toe of cuts.

Survey marks such as property corners, right-of-way lines, subgrade elevations, and slope stakes.

Placement, protection, and replacement of survey monuments.

When no profile has been established for the streets abutting and leading to a development site, the City may require a survey of the street area by a licensed surveyor for the purpose of establishing the proposed centerline profile and the transition between the right-of-way and on-site.

Flood Zone Elevation Certificates require surveyed finished floor elevations to confirm that structures meet the elevations set by the City.

Record drawings with as-constructed (surveyed) information must be provided for private infrastructure that connects to the City's infrastructure, for public facilities, and for right-of-way work.

## 4.2. Plans and Specifications

The plans must clearly indicate the location, nature, and extent of the proposed work and must provide sufficient detail to show that all provisions of the standards and codes are met. Specifications must accompany the plans whenever the plans and notes do not adequately describe the proposed work and materials.

## 4.3. Survey

### Survey Reference.

Horizontal Datum: All survey work, including but not limited to mapping, platting, planning, design, right-of-way surveys, and construction surveys, shall be in the Washington State Plane Coordinate System, North Zone, using NAD 83(1991) datum.

The plans shall show the horizontal control used to establish ties to the datum, with type, size and location, date visited, and the State Plane coordinates for each monument used.

Vertical Datum: All survey work, including but not limited to mapping, platting, planning, design, right-of-way surveys, and construction surveys, shall be in the North America Vertical Datum of 1998 (NAVD 1988).

The plans shall show the benchmarks used to establish ties to the datum, with reference number, description, location and elevation of each benchmark used, and any project site benchmarks.

For Flood Elevation certificates, a conversion from 1988 NAVD to 1929 NAVD may be provided.

All real properties, including parcels, rights-of-way, and easements must be located or staked on the ground, starting from a monument.

Legal descriptions of the horizontal and vertical locations require the location of a monument as their beginning point of reference.

Refer to Appendix B – Survey Criteria.

#### 4.4. Site Assessment

A site assessment for drainage design is required for medium impact and large impact projects. Refer to Division 3 – Surface Water and the Department of Ecology’s Stormwater Management Manual for Western Washington (the Stormwater Manual) for more information.

#### 4.5. Surface Water Report

The scope of drainage review varies with the project complexity and potential surface water impacts. A drainage report may be required. Refer to Division 3 – Surface Water and Appendix C – Surface Water Report Guidelines for design and report requirements.

#### 4.6. Geotechnical Report

A geotechnical report helps determine if the proposal for a site is appropriate. In addition to geotechnical reports required to support building designs a geotechnical report is required for: 1) land fill or excavation over 500 cubic yards, 2) work on sites containing or adjacent to slopes that are 15 percent or steeper and 3) for some storm drainage design. Refer to SMC Chapter 20.80 for critical area information.

Refer to Appendix D – Geotechnical Report Guidelines for the approved report format.

For site development on a site with no steep slopes, erosion hazards, or critical areas, a report previously prepared for that site may be accepted if:

The report is less than five years old and no significant changes have occurred.

The geotechnical engineer/engineering geologist who signed the report provides a letter stating the report is still applicable to the site and currently proposed project.

#### 4.7. Transportation Impact Analysis

A transportation impact analysis is required for each development or redevelopment that would generate 20 or more trips during the PM peak hour (SMC Chapter 20.60) per the most recent edition of the Trip Generation Manual, published by the Institute of Traffic Engineers (ITE).

Refer to Chapter 8, Transportation Impact Analysis and Appendix E – Transportation Impact Analysis Report Guidelines for guidance.

#### 4.8. Traffic Control Plan

Prior to beginning any activity which might affect City right-of-way, the Applicant shall provide the City, for review and approval as part of a right-of-way use permit, a traffic control plan that meets Manual of Uniform Traffic Control Devices (MUTCD) standards.

The traffic control plan must accurately reflect existing right-of-way conditions including accesses, channelization, sidewalks, bike/pedestrian paths, bus stops, hydrants, trees, poles, and pavement edge. The traffic control plan must allow for continued emergency services. For pedestrian and business disruption, the plan shall contain adequate connections and clear signage.

#### 4.9. Declaration of Covenant

The City requires a Declaration of Covenant for all permanent surface water Best Management Practices on all projects, both private and public. The City will supply the Covenant paperwork for completion. Final signature and recording with the King County Recorder's Office will be done by the Applicant. After recording, the applicant shall return a copy to the City.

#### 4.10. Easements

Easements must be provided when facilities on private property will be used by more than one lot or will benefit the public (SMC Chapter 20.70 Easements and Tracts).

Utilities: Each utility (water, sewer, power, etc.) determines the minimum width for an easement. Refer to Division 3 – Surface Water for more information on drainage easements.

Pedestrian/Bicycle: For traffic safety or access to schools, playgrounds, urban trails, shopping facilities, or other community facilities, bikeways or walkways must be a minimum of five feet wide. Additional width may be required.

Nonmotorized: Nonmotorized easements facilitate pedestrian circulation between neighborhoods, schools, shopping centers, and other activity centers. A nonmotorized easement shall be wide enough to include the trail plus at least two feet on each side.

Roadway: Either the street's functional classification or its particular design features may necessitate slope, sight distance, wall, or drainage easements beyond the right-of-way line. Such easements may be required in conjunction with dedication or acquisition of right-of-way pursuant to SMC Chapter 20.70.

#### 4.11. Tracts

Tracts should be used for facilities used by a broader group of individuals than easements, may have some degree of access by the public, and typically require regular maintenance activities. Examples of facilities that may be located in tracts include private streets or drainage facilities serving more than one lot. Tracts are not subject to minimum lot size standards for the zone, although they must be large enough to accommodate the facilities and activities located within them.

A publicly maintained stormwater facility shall be located in the roadway right-of-way or in a tract dedicated to the City. At a minimum, the tract shall include the entire facility, site access area, and at least five feet around the facility. In limited cases, an easement may be permitted. If an easement is permitted, dimensions shall be determined by the City.

#### 4.12. Dedication

Dedication shall occur at the time of recording for subdivision, or prior to permit issuance for construction projects.

The City may require right-of-way dedication to incorporate necessary transportation improvements. Refer to SMC Chapter 20.70 for more information.

The Public Works Director may grant some reduction in the minimum right-of-way requirement where it can be demonstrated that sufficient area has been provided for all frontage improvements, including utilities, within the right-of-way.

Dedications may be required in the following situations:

Accommodation of motorized and nonmotorized transportation, landscaping, utility, street lighting, and traffic control devices, and buffer requirements;

The development project abuts an existing substandard public street and the additional right-of-way is necessary to incorporate future frontage improvements for public safety;

Right-of-way is needed for the extension of existing public street improvements necessary for public safety.

Right-of-way is needed in order to incorporate improvements that are reasonably necessary to mitigate the direct impacts of development.

#### 4.13. Dewatering Plan

Dewatering is defined as the removal and appropriate discharge and release of surface water and subsurface water. Temporary dewatering that occurs during construction must have a Temporary Dewatering Plan reviewed and approved by the City before dewatering begins.

#### 4.14. Maintenance Plan

For commonly-owned improvements on private property, such as access, utilities, or surface water improvements, the Permittee prepares and submits an Operations and Maintenance Plan for City review before recording the plan with King County Recorder's Office. The maintenance plan must spell out agreements between the joint owners regarding maintenance responsibility and maintenance costs.

#### 4.15. Financial Guarantee

The City determines the performance and maintenance financial guarantee amounts. The performance guarantee must be submitted before permit issuance. The maintenance guarantee must be provided before final approval.

#### Performance.

The City requires a performance guarantee to cover the construction costs of proposed right-of-way improvements.

A performance guarantee may be required for proposed on-site improvements such as landscaping, tree replacement, critical area restoration, storm water facilities installation, and for erosion prevention and sediment control on projects which clear more than 7,000 square feet, or contain or abut critical areas such as steep slopes, wetlands, or streams.

Performance financial guarantees remain in full force and effect until:

The obligations secured are fully performed as determined by the City's inspection program;

A guarantee for maintenance and operation of all improvements for a guarantee period have been submitted to the City; and

The City has released the guarantee in writing.

The guarantee may be released in increments as improvements are completed and have satisfactorily met all inspection requirements of the City.

#### Maintenance.

A maintenance guarantee will be required to guarantee maintenance and operation of right-of-way improvements for a period of at least two years.

A maintenance guarantee may be required to guarantee maintenance and operation of on-site improvements for a period of at least two years.

For low impact development or for innovative technologies, the maintenance financial guarantee term may be up to three years.

For tree replacement, a maintenance guarantee is required for three years.

For critical area restoration, a maintenance guarantee is required for five years.

## 4.16. Insurance

As a condition of the City permitting work within the public right-of-way, it is required that a certificate of liability insurance is provided indicating that the permittee and /or contractor are covered by a Commercial General Liability insurance policy.



Additionally, when the City determines that the nature of any work on public or private property is such that it may create a hazard to human life, endanger adjoining property, street, street improvement, or any other public property; the City may require the Permittee to provide a Certificate of Liability Insurance. In this case the City shall determine the amount of insurance based on the nature of the risks involved.

The minimum Commercial General Liability insurance limits are to be no less than \$1,000,000 each occurrence, \$2,000,000 general aggregate and \$2,000,000 products completed operation aggregate limits.

The required liability insurance must be maintained for the duration of construction activities.

The City must be named as an insured under the Commercial General Liability insurance policy using ISO Additional Insured-State or Political Subdivisions-Permits CG 20 12 or a substitute that provides and equivalent endorsement.

## Chapter 5. Permit Fees

Planning and Development Services establishes and collects fees as set forth in the fee schedule adopted by the City Council (SMC Chapter 3.01).

Plan review and submittal fees are collected when the application is submitted. Additional fees, due and payable when the permit is issued, independent review costs, and additional inspection or review time, and transportation impact fees.

### 5.1. Fee-in-lieu of Frontage Improvements

The City does not accept Fee-in-lieu of Frontage Improvements at this time for locations within the City.

In the instance where streets will be improved as a whole through a capital improvement project or local improvement district within five years of permit issuance, a contribution may be made and calculated based on the improvements that would be requested on the development. (SMC 20.70.320)

### 5.2. Independent Review

Depending on the site conditions and design complexity, reports submitted to the City, such as geotechnical or wetland reports, may receive independent review. The permit Applicant pays the review fee.

### 5.3. Revisions to Issued Permits

The cost to review revisions to an issued permit is charged at the currently adopted hourly review rates. These fees must be paid when the revision is issued and before the permit receives final approval.

### 5.4. Transportation Impact Fees

As per SMC 12.40 the City has adopted impact fees for transportation as a condition to all new developments within the City. These fees are collected at the time of issuance of approved building permits. Fees are calculated based on the type of development listed in the adopted fee schedule.

Fee amounts are calculated during the permit review either by the city or through an approved independent fee calculation.

Page intentionally left blank.

## DIVISION 2 – RIGHT-OF-WAY

Division 2 – Right-of-Way sets forth minimum engineering design criteria to support public safety and welfare within the right-of-way. Every effort has been made to ensure that these standards are in line with AASHTO, FHWA, ITE, and WSDOT standards.

The Public Works Director (Director) shall have the authority to administer the provisions of these technical standards, to determine applicability, to interpret unclear provisions, to determine the level of detail and methodologies for required analysis, and to promulgate procedures and rules for unique circumstances not anticipated within the standards and procedures contained within this Engineering Development Manual (EDM).

These standards do not substitute for engineering design, nor are these standards intended to limit innovative design where equal performance in value, safety, and maintenance can be demonstrated. More stringent design standards or specifications may be required where special conditions warrant.

All facilities in the right-of-way, unless specifically excluded, shall be designed by or under the direct supervision of a professional engineer licensed in Washington State. All right-of-way drawings, designs, sections, details, standard plans, and supporting data submitted to the City of Shoreline for approval, unless specifically excluded, must be stamped, signed, and dated by the engineer of record.

Page intentionally left blank.

## Chapter 6. Standards

Design detail, construction workmanship, and materials shall be in accordance with these technical standards and the latest edition of the following companion documents. Design and construction shall meet the applicable standards and codes, and the recommendations in specific reports, such as the geotechnical report, the traffic impact study, and the surface water report.

The following publications provide the basis for design and construction requirements for public or private development within the City:

- City of Shoreline Comprehensive Plan
- City of Shoreline Transportation Master Plan (TMP)
- City of Shoreline Surface Water Master Plan
- City of Shoreline Municipal Code (SMC)

### 6.1. Companion Documents

When standards or other design criteria are not specifically addressed in the EDM, then the latest editions of the following shall govern the design.

Transportation design standards:

- A Policy on Geometric Design of Highways and Streets, AASHTO
- Guidelines for Urban Arterial Program, WSDOT
- Urban Street Geometric Design Handbook*, Institute of Transportation Engineers
- Guide for Bicycle Facilities, AASHTO
- ADA Standards for Accessible Design

Surface Water design standards:

- Stormwater Management Manual for Western Washington* (Stormwater Manual), Department of Ecology as amended in Chapter 19 Stormwater Manual Modifications; available online at <http://www.ecy.wa.gov/programs/wq/stormwater/manual.html>
- King County Surface Water Design Manual*, Chapter 4 “Conveyance System Analysis and Design,” as amended in Chapter 27 Conveyance System; available online at <http://www.kingcounty.gov/environment/waterandland/stormwater/documents/surface-water-design-manual.aspx>

*Highway Runoff Manual*, (HRM) M31-16.04, WSDOT; Only publically funded linear transportation projects may use the BMPs and minim design requirements, except LID Feasibility (HRM Section 405.2 and within individual BMP design criteria in Section 5-4) available online at :

<http://www.wsdot.wa.gov/Publications/Manuals/M31-16.htm>

Traffic Control design standards: *Manual on Uniform Traffic Control Devices*, Federal Highway Administration; available online at: <http://mutcd.fhwa.dot.gov/>

State Highway guidelines: *Local Agency Guidelines*, WSDOT

Construction specifications: *Standard Specifications for Road, Bridge, and Municipal Construction* M 41-10, WSDOT; WSDOT Manuals are available online at:

<http://www.wsdot.wa.gov/Publications/Manuals/>

The following shall be applicable when pertinent, when specifically cited in these standards or when required by state or federal funding authority:

*Highway Capacity Manual*, Transportation Research Board

Standard Rock Wall Construction Guidelines, Associated Rockery Contractors

National Electrical Installation Standards (NEIS)

American Society for Testing and Materials (ASTM)

Design criteria of federal agencies including the Federal Housing Administration, Department of Housing and Urban Development, and the Federal Highway Administration, Department of Transportation.

## 6.2. Deviation from Engineering Standards

Deviation from engineering standards is a mechanism to allow the City to grant an adjustment in the application of engineering standards where there are unique circumstances relating to the proposal. (SMC Chapter 20.30.290)

Deviations are submitted though a permit application and reviewed to determine that all requirements are met. (SMC Chapter 20.30.290)

Deviations, exceptions or modifications to the Stormwater Management Manual contained in SMC 12.10.200 are not subject to the Deviation requirements outlined in SMC Chapter 20.30.290. Instead



they are subject to the parameters provided in the Stormwater Management Manual for Western Washington and approved by the Director of Public Works or designee.

## Chapter 7. General Requirements

This chapter provides general requirements related to transportation improvements.

### 7.1. Americans with Disabilities Act

All designs shall meet the current Americans with Disabilities Act (ADA) requirements and standards. In the event field conditions prohibit meeting the ADA requirements, the Engineer must submit documentation that the design meets ADA to the maximum extent feasible. The City standard for ADA requirements is the 2011 PROWAG.

### 7.2. Low Impact Development

Requirements for low impact development apply to both onsite improvements and improvements in the right-of-way. Refer to the Stormwater Manual as adopted and amended in Chapter 19 to ensure work meets the requirements in this manual.

LID techniques within the right-of-way are at the approval of the Director or designee.

### 7.3. Maintenance

The City of Shoreline maintains and repairs all of its public streets and sidewalks. SMC Chapter 12 defines the responsibility for maintenance of right-of-way as defined in Table 6, Right-of-way Maintenance Responsibilities. According to SMC Chapter 12, “it shall be the responsibility of the owner of the property abutting upon a public sidewalk to maintain the sidewalk at all times in safe condition, free of any and all obstructions or defects, including but not limited to, ice and snow.” The City is responsible for vegetation removal in the right-of-way during emergencies, in order to remove hazards and protect public safety.

**Table 6. Right-of-Way-Maintenance Responsibilities**

Street Classification	Landscaping	Sidewalk (clear/clean)	Sidewalk (repair)	Trees	Driveway Approach
Principal, Minor, or Collector Arterial Streets	City	Abutting property owner	City	City	Abutting property owner
Local Primary Street	City	Abutting property owner	City	City	Abutting property owner

Local Secondary "Green" Street	Abutting property owner	Abutting property owner	City	City	Abutting property owner
-----------------------------------	-------------------------------	----------------------------	------	------	----------------------------

#### 7.4. Tree Removal/Pruning

Tree removal and pruning in the right-of-way is regulated by SMC 12.30.040 and SMC 20.50.360.

#### 7.5. Connectivity

In order to provide connectivity, street layouts shall continue streets in adjoining developments(s) or their anticipated locations where adjoining property is not yet developed.

#### 7.6. Underground Utilities

The following applies to the connection from the distribution lines in the right-of-way to the property it serves (service connection);

If the existing service connections in an area are underground, new service connections must be underground.

Existing overhead facilities, including utility poles will be allowed to remain above ground until one of the following events;

1. The city council designates for undergrounding a capital improvement or public works project;
2. An entity instigates a joint trenching project that could reasonably serve to replace existing overhead facilities;

#### 7.7. Frontage Improvements

Standard frontage improvements consist of right-of-way dedication, curb, gutter, sidewalk, amenity zone and landscaping, drainage improvements, and pavement overlay up to one-half of each right-of-way abutting a property as defined in the Master Street Plan.

Additional improvements may be required to ensure safe movement of traffic, pedestrians, bicycles, transit, and nonmotorized vehicles. The improvements can include transit bus shelters, bus pullouts, utility undergrounding, street lighting, signage, and channelization.

When a development proposal triggers frontage improvements, existing frontage improvements shall be upgraded to current standards.

Acknowledging that the City is a built environment, design and installation of new or replaced frontage improvements may be adjusted during design or installation, with approval from the Director, to meet the existing conditions. Approval may require a formal deviation, as determined by the Director.

The Master Street Plan (Appendix F) defines street widths, curb locations, sidewalk widths and other right-of-way requirements for all streets.

The frontage improvements run the full length of the property line/right-of-way line. Transitions to existing conditions occur outside the development frontage.

An amenity zone is required, except where an alternate street design has been approved, or where protection of critical areas requires special consideration.

Required frontage improvements must be installed, inspected and approved by the City prior to final approval of the related building/site development permits and before a Certificate of Occupancy is issued or a permit receives final approval.

## 7.8. Dedication of Right-of-Way

Dedication shall occur at the time of recording for subdivisions, or prior to permit issuance for construction projects.

The City may require right-of-way dedication to incorporate necessary transportation and frontage improvements. Refer to SMC Chapter 20.70 for more information.

## 7.9. Illumination

Seattle City Light (SCL) maintains and establishes service connections for street lighting within the City of Shoreline. When new street lighting is required, the Developer works with the Public Works Department and SCL regarding design and installation. The Developer pays the costs associated with the design and installation of the light. These costs may include new electrical service and/or a new pole.

Where a half-street improvement is required in conjunction with a development, the roadway width to be used for illumination design purposes will be the actual width of the roadway at the time of design and not half of the ultimate width. All existing luminaires shall be evaluated for upgrades to present standards. Lighting standards must be approved by Seattle City Light, consistent with Seattle City Lights' Stock Catalog.

All new and retrofitted lighting systems shall be Light Emitting Diode (LED).

All lighting shall conform to NEIS standards. Street lighting system designs shall be stamped by a licensed engineer experienced with lighting design and shall include the following: luminary spacing, illumination level, uniformity ratio, line losses, power source, the electrical and physical layout, installation details, plans and specifications. All designs must be approved by the City Engineer.

For City-owned illumination systems, lighting level requirements for roadways are defined in Appendix J. Other criteria are as follows:

Intersections shall have a minimum light level equal to 1.5 times the average light level requirement of the intersecting street with the highest classification. Intersection uniformity shall be less than or equal to the uniformity of the intersecting street with the highest classification.

All marked crossings shall be illuminated with at least one luminaire oriented parallel to the crossing. Average maintained light levels within pedestrian facilities shall be as follows:

**Table 7. Pedestrian Facility Light Levels**

Pedestrian Facility Type	Minimum Maintained Avg. (fc)	Uniformity Ratio (Avg/Min)
<b>Marked intersection or mid-block crossing</b>	1.0	3:1
<b>Unmarked crosswalk at intersection</b>	Same as adjacent intersection	
<b>Sidewalk:</b>		
<b>Residential</b>	1.0	4:1
<b>Commercial</b>	.4	4:1

As-constructed street lighting plans for City-owned systems shall be provided to the City on CD-ROM in CAD or Portable Document Format (PDF) and on 22-inch by 34-inch mylars prior to final occupancy or final plat approval.

Street lighting systems shall be designed to be accessible by a wheeled vehicle weighing 30,000 lbs.

Contractor cabinets equipped with electrical meters, time clocks, circuit breakers, and other required components are required on arterial installations of five or more street lights or as required by the Public Works Director.

The exact location of the power source shall be indicated together with the remaining capacity of that circuit. System continuity and extension shall be provided.

Street lighting is encouraged but not required along private streets. Street lighting systems for private streets shall be designed and constructed on a separate power source from the public street lighting system. All street light maintenance, installation, and power costs for private street systems shall be paid by the property owner, homeowner, or homeowners' association.

## 7.10. Curbing

Curb and gutter shall be Type A on all street classifications; however, 24-inch wide vertical curb may be used for uniformity or replacement.

Rolled curb is not allowed, unless it replaces or matches existing, and it is approved by the Director.

Extruded curb is not allowed in public right-of-way, unless it is temporary and it is approved by the Director.

## 7.11. Pavement Cut Moratorium

The following applies to a utility doing work such as system repair or expansion within the right-of-way. This moratorium does not apply to utility service installation required for new development or redevelopment.

Any street that has been constructed, reconstructed, resurfaced, overlaid or paved within the past five years cannot be cut for five years unless:

A deviation to the engineering standards and to SMC Chapter 12.15 is approved; or  
It is allowed through a valid franchise agreement.

Emergency situations are exempt from the five-year moratorium. A right-of-way permit shall be applied for within one working day following the emergency.

Page intentionally left blank.



## Chapter 8. Transportation Impact Analysis

A Transportation Impact Analysis (TIA) is required if:

- A. A development or project proposal would generate 20 or more new vehicle trips during the PM peak hour; or
- B. The City Traffic Engineer assesses that the project will have significant impacts to the transportation system. This may be required at the discretion of the City Traffic Engineer even if the 20-trip threshold is not met.

A Regional Transportation Analysis (RTA) is required if:

A development or project would generate 100 peak hour trips or more.

In addition to the general Transportation Impact Analysis criteria, an RTA shall have an expanded study area for impacted intersections and roadways, and shall include a thorough assessment of impacts to non-motorized, transit, neighborhood streets, and parking.

Components of the RTA may be required at the discretion of the City Traffic Engineer for projects that generate between 20 and 100 trips.

The level of detail to be included in the TIA depends on the complexity of the proposed project.

The Transportation Impact Analysis (TIA) or Regional Transportation Analysis scope is developed with the City Traffic Engineer. Please contact the City Traffic Engineer in Public Works for details including background traffic growth information, trip distribution and assignment assumptions, and intersections and/or roadways required for study.

If the proposed project is changed by type or size or the study is older than two (2) years, updates to the TIA will be required.

See Appendix E for Transportation Impact Analysis guidelines.

## Chapter 9. Street Classification

Federal and State guidelines require that streets be classified based on function. The City mainly classifies streets as arterial or non-arterial (local). Other classifications include alley and private streets.

### 9.1. Arterial Streets

Arterials provide a high degree of vehicular mobility through effective street design and by limiting property access to the right-of-way. Most vehicle trips on arterials are through-traffic. Arterials are divided into three classes: Principal, Minor and Collector Arterials. Higher classification arterials (Principal being the highest), have larger traffic volumes, more through-traffic, and longer trips, and have fewer access points.

Principal Arterials have higher levels of local land access controls, with limited driveway access, and have regional significance as major vehicular travel routes that connect metropolitan areas. *(Examples: Aurora Avenue N, NE 175th Street and 15th Avenue NE)*

Minor Arterials generally provide a high degree of intra-community connections and are less significant than Principal Arterials when considering regional mobility. *(Examples: Meridian Avenue N, N/NE 185th Street and NW Richmond Beach Road)*

Collector Arterials assemble traffic from the interior of an area/community and deliver it to the closest Minor or Principal Arterial. Collector Arterials provide mobility, and access to property. *(Examples: Greenwood Avenue N, Fremont Avenue N and NW Innis Arden Way)*

### 9.2. Non-Arterial Streets

Streets that are not designated as arterials are non-arterial streets. Shoreline divides non-arterial streets into Local Primary and Local Secondary classifications.

### 9.3. Alley

An alley is a public right-of-way that serves as a service roadway providing a primary or secondary means of automobile, service vehicle, or emergency vehicle access to abutting property. An alley is not intended for primary traffic or pedestrian circulation. The City does not maintain alleys.

### 9.4. Private Street

A private street is a privately owned and maintained street providing vehicular access within a property or properties. The City may approve a private street under certain conditions. (SMC 20.70.240) Refer to Chapter 12.8, Private Streets for more information.

**Table 8. Street Classification Characteristics (typical)**

	ARTERIAL STREETS			NONARTERIAL STREETS	
	Principal	Minor	Collector	Local Primary	Local Secondary
Function	<ul style="list-style-type: none"> <li>- Connect cities and urban centers with minimum delay</li> <li>- Channel traffic to Interstate system</li> <li>- Accommodate long and through trips</li> </ul>	<ul style="list-style-type: none"> <li>- Connect activity centers within the city</li> <li>- Connect traffic to Principal Arterials and Interstate</li> <li>- Accommodate some long trips</li> </ul>	<ul style="list-style-type: none"> <li>- Access to community services and businesses</li> <li>- Connect non-arterial to Minor and Principal Arterial</li> <li>- Accommodate medium-length trips</li> </ul>	<ul style="list-style-type: none"> <li>- Connect Local Secondary to Arterials</li> <li>- Provide local access</li> <li>- Accommodate short trips to neighborhood destinations</li> </ul>	<ul style="list-style-type: none"> <li>- Provide local access</li> </ul>
Speed Limit (mph)	30-40	30-35	25-35	25	25
Daily Volumes (vpd)	>15,000	7,000-20,000	2,000-8,000	<3,000	<3,000
Lanes	Three or more	Two or more	Two or more	One or two	One or two
Striping	Travel lanes delineated	Travel lanes delineated	Travel lanes delineated	No centerline striping	No centerline striping
Buses/Transit Stops	Allowed	Allowed	Allowed	Allowed for short segments	Not allowed
Bicycle Facilities	Lanes, shared lanes, or signage	Lanes, shared lanes, or signage	Lanes, shared lanes, or signage	Shared lanes/signs	No specific bicycle facilities; may have signed route
Pedestrian Facilities	<ul style="list-style-type: none"> <li>- Sidewalks both sides</li> <li>- Amenity strips</li> </ul>	<ul style="list-style-type: none"> <li>- Sidewalks both sides</li> <li>- Amenity strips</li> </ul>	<ul style="list-style-type: none"> <li>- Sidewalks both sides</li> <li>- Amenity strips</li> </ul>	<ul style="list-style-type: none"> <li>- Pedestrian access through use of sidewalks, trails, or other</li> </ul>	<ul style="list-style-type: none"> <li>- Pedestrian access through use of sidewalks, trails, or other</li> </ul>

Source: 2012 Transportation Master Plan, Table 2.1

Page intentionally left blank.

## Chapter 10. Access Management

Access management recognizes the need to balance the need for access to private properties with the need to maintain safety, capacity and level of service on the streets that provide access. Landowners abutting City rights of way have a right to access, but the particular means of access shall be reviewed and approved by the City.

Safety and the existing and future function of each street are the foremost factors in determining the number, location, and design of street accesses. Roadway design elements such as auxiliary lanes, medians, channelization and safe stopping and turning sight distances are also factors in access management, as are the elements of land development such as internal site circulation and parking layout. Access management is implemented via the Right of Way Use and Site Development permitting processes.

### 10.1. General

#### A. Authority:

1. City of Shoreline Rights of Way: The Director approves the design, number, and location of access points to City of Shoreline rights of way. When changes in land use result in changes of the type and operation of access, the access location and design will be reviewed with the development plans and shall be construction or modified to meet current standards
2. State Highways: Access to State highways is regulated by the Washington State Department of Transportation (WSDOT) pursuant to 47.50 RCW and 468-51 and 468-52 WAC. Two classifications of State highway exist within Shoreline *Limited Access* and *Managed Access*. Interstate 5 is the only Limited Access Highway within the City of Shoreline. SR 99 (Aurora Avenue N), SR 522 (Bothell Way NE), SR 523 (N/NE 145th Street) and SR 104 (Ballinger Way NE) are Managed access highways within or adjacent to the City of Shoreline. For information on access permitting through WSDOT, please visit the WSDOT Access Management website:  
<http://www.wsdot.wa.gov/Northwest/DevelopmentServices/AccessServices.htm>

3. Construction or improvement of an access, approach or driveway, or construction of any classification of street, that will intersect a State highway, shall be designed in accordance with this Engineering Development Manual and WSDOT requirements. Where applicable state or federal standards exceed the requirements of this manual, state or federal standards shall govern.
- B. Consolidation of Access. In the interest of safety and efficient traffic operations access to individual and contiguous parcels should be consolidated to the extent practicable. Access will be reviewed and approved to minimize conflicts between vehicles, pedestrian and bicycle traffic, and traffic entering and exiting adjacent driveways.
- C. Required Access. All new development shall be served by adequate vehicular access as follows:
1. Every lot upon which one or more building(s) is proposed to be erected, or where a traffic generating use is proposed, shall establish direct access from the street right-of-way, access easement or fire lane, as needed to provide public services such as fire protection, emergency medical service, mail delivery or trash collection.
  2. The circulation system of the proposed development shall intersect with existing and planned streets abutting the site at approved locations
  3. The circulation system within the proposed development shall provide direct connections to adjacent developments (inter-parcel) where appropriate and/or required; and,
- D. Backing into the Right-of-Way. Driveways, parking, or loading areas that require backing maneuvers in a public street shall be approved only for single-family or duplex residential uses abutting a Local Secondary street.
- E. Maintenance. Maintenance of driveway approaches shall be the responsibility of the owner whose property they serve.
- F. Restriction of Turning Movements. Conflict reduction measures have been provided or may be required to safely manage turning traffic to and from the development site. Median design and driveway channelization are appropriate to reduce conflicts. Traffic control devices

controlling traffic from private property shall be installed and by the property owner at no cost to the City.

- G. **Abandoned Access.** All abandoned accesses on the same frontage shall be removed within 30 days after abandonment and the curbing, sidewalk and amenity zone, or shoulder and ditch section shall be restored to meet current standards.
- H. **Temporary Access.** The City Engineer may grant temporary access to accommodate phased development of a site in accordance with an approved phasing plan. Temporary access shall be removed, relocated, redesigned, or reconstructed after permanent, approved access is constructed.

## 10.2. Access Provision

- A. Consolidate accesses to adjacent or contiguous parcels to the extent practicable. Each parcel shall have access to a public right-of-way by:
  - 1. Direct access to a right-of-way; or,
  - 2. By a recorded easement providing shared access; or,
  - 3. By a recorded tract providing shared access.
- B. No more than one access shall be provided to an individual parcel, or to contiguous parcels under the same ownership, or to parcels that are included in the same subdivision or project, unless approved by the City Engineer. Additional access may be granted to contiguous parcels if they meet minimum spacing requirements or if a Traffic Engineering Study acceptable to the City Engineer demonstrates that the additional access will not adversely affect safe operation of the street.
- C. Minimum Spacing: The minimum distance between access connections is 50 feet on the same side of the street.
- D. Multiple Frontages: Access for projects with multiple frontage will be off the lower classified road except as required by code. Additional access will be allowed provided spacing requirements are met.
- E. Circular Driveway: Circular driveways shall meet all of the following criteria:
  - 1. The property frontage must be at least 100 feet.



2. The accesses are onto a Local Secondary street. Circular driveway access shall not be permitted onto Arterial Streets.
  3. Safe stopping sight distance is available for both driveways, as demonstrated by a sight distance analysis prepared by a professional engineer licensed in Washington State and acceptable to the City's Traffic Engineer.
  4. Circular driveways serving residential parcels shall be separated by a minimum of 40 feet between their closest points. Circular driveways serving commercial or multi-family parcels shall be separated by a minimum of 30 feet.
  5. Driveways shall be no closer than 10 feet to the side property line, measured from the point at which the prolongation of the driveway edge intersects the right-of-way line.
  6. Driveways shall not exceed 20 feet in width for residential parcels and shall not exceed 30 feet in width for commercial or multi-family parcels.
- F. Transition Areas: Properties deemed to be within a Transition Area shall follow requirements in the SMC 20.50.021.C: All vehicular access to proposed development in commercial zones shall be from arterial classified streets, unless determined by the City Engineer to be technically infeasible or in conflict with state law addressing access to state highways.
- G. Traffic Impact Analysis: All developments in commercial zones shall conduct a transportation impact analysis per the Engineering Development Manual. Developments that create additional traffic that is projected to use local streets may be required to install appropriate traffic-calming measures. These additional measures will be identified and approved by the City Traffic Engineer.

## Chapter 11. Access Design

All accesses shall be located, designed, and constructed to minimize traffic congestion and maximize public safety on the street system. This chapter provides location and design criteria for access at the right-of-way line, access approach in the right-of-way, and driveways internal to a property.

### 11.1. General

- A. Access. Access to the right of way shall be designed as an access approach.
- B. Design. The designers of proposed developments shall comply with required grade transitions while considering building setback, terrain, and existing and designed grades.
- C. Emergency Vehicles. All accesses shall be located and designed to readily accommodate emergency vehicles that would ordinarily respond at the particular establishment. The International Fire Code (IFC) and SMC Chapter 15 shall also apply to driveways designated as fire lanes and/or fire apparatus access roads.
- D. Traffic Control Devices. All on-site traffic control devices, including signs and pavement markings, shall meet the MUTCD standards.

### 11.2. Access Width

The access width is measured at the right-of-way/property line. Table 8. Provides maximum/minimum access widths. The City Engineer may approve a wider access when the traffic study or the turning radius of the appropriate design vehicle turning radius warrants the wider access. Minimum tract/easement widths shall be maintained on to the property a minimum of 20 feet from the right-of-way line or to the nearest property line of the most distant lot sharing the access, whichever is further.

**Table 9. Access Widths**

Access Types	Non-arterial Streets		Arterial Streets	
	Width (FT)		Width (FT)	
	Min.	Max.	Min.	Max.
Residential	10	20	10	20
Shared	20	30	20	30
Multi-family	20	30	20	30
Commercial	20	30	20	36
Circular Drive	10	12	NA	NA
Private Street	20	30	20	30

### 11.3. Access Clearance from Intersection and Property Lines

A. Minimum Offset Distance from Side Property Lines: Driveways shall be offset a minimum of 10 feet from side property lines, measured at the prolongation of the driveway’s intersection with the right of way line.

1. Exceptions: the minimum offset distance from side property lines shall be:
  - a. Zero feet for cul-de-sac flag lots, lot widths of 30 feet or less and for shared driveways that serve two or more abutting parcels;
  - b. Three feet for lot widths between 30 feet and 50 feet.

B. Minimum Clearance from Intersections:

1. Local Streets: Driveways accessing Local Secondary or local Primary streets shall be located at least 50 feet from the right of way line of the nearest intersection street, or at the minimum offset distance from the parcel’s side property line that is farthest from the intersection.
2. Minor & Collector Arterial Streets: Driveways accessing Minor Arterial or Collector Arterial streets shall be located at least 75 feet from the right of way line of the nearest

intersecting street, or at the minimum offset distance from the parcel's side property line that is farthest from the intersection, whichever is greater.

3. Principal Arterial streets: Driveways accessing Principle Arterial streets shall be located at least 150 feet from the right of way line of the nearest signalized intersection, or 100 feet from the nearest un-signalized intersection, or at the minimum offset distance from the parcel's side property line that is farthest from the intersection, whichever is greater. Left-turn restrictions may be imposed at driveways that do not meet the foregoing criteria.

C. Corner Parcels: Access to commercial or multi-family corner parcels shall be located on the lower-classification street at the property line most distant from the right of way line.

D. An access shall not be placed in a curb setback or bulb out.

#### 11.4. Access Approach

A paved access approach shall be provided between the property line and the edge of pavement in the right-of-way. Approaches must conform to Standard Plans 301-306 based on site conditions.

The maximum change in access approach profile grade, within the right-of-way, shall be 6 percent within any 10 feet of distance on a crest vertical curve and 12 percent within any 10 feet of distance in a sag vertical curve.

No portion of an access approach shall be allowed within 3 feet of side property line in residential areas, or within 10 feet in commercial areas, measured perpendicular to the side property line that is projected into the right-of-way, except:

On a cul-de-sac bulb as necessary for proposed residential access;

A shared driveway per Standard Plan 307 Shared Driveway.

**Culvert Requirements:** A drainage culvert is required for access approach that crosses an open ditch section. Minimum culvert internal diameter shall be 12 inches, or larger if required to carry anticipated stormwater flows. Refer to Chapter 27 Conveyance System for additional information regarding required culvert size and materials.

## 11.5. Driveway

A driveway, including the landing, extends from the access at the property line/right-of-way line onto the property.

Driveways shall be graded to blend into possible future road section without encroachment into graded shoulder or sidewalk.

A shared driveway has one access to the right-of-way via a shared tract or easement on the private property. Minimum tract/easement length shall be 20 feet from the right-of-way line, whichever is farther. Refer to Standard Plan 307 Joint Use Driveway Tract.

Driveways must be paved to the nearest property line of the most distant lot sharing the access or 20 feet, minimum, whichever is farther.

All driveways should be 90° to the street at the right-of-way access unless an Engineering Deviation is approved.

A landing on a driveway accessing an arterial shall not exceed a 1V:30H slope for a distance of 30 feet. For an access to a local street, the landing slope shall not exceed 1V:20H slope for a distance of 20 feet. Refer to Standard Plan 215 Intersection Landing.

The maximum driveway profile grade is 15 percent. The Fire Department may approve steeper grades for short distances.

The maximum change in driveway grade shall be 8 percent within any 10 feet of distance on a crest and 12 percent within any 10 feet of distance in a sag vertical curve.

Grade breaks, including the tie to the roadway, will be constructed as smooth vertical curves.

## 11.6. Parking Lot Throat Lengths

Traffic signage in a parking lot shall meet Manual of Uniform Traffic Control Devices requirements.

The required throat length at a parking lot access to public right-of-way is determined during the permit review process and is based on the Transportation Impact Analysis.

The throat length vehicle storage in parking lots is based on a typical vehicle spacing of 20 feet, but may be increased where larger vehicles can be expected.

The City may adjust the on-site throat lengths for accesses with two approach lanes, subject to the traffic analysis findings, roadway geometry, traffic volumes, and site layout.

On-site storage is measured from the right-of-way line to the first parking stall or drive aisle in a parking lot.

Outbound: The throat shall be of sufficient length to provide adequate storage of outbound vehicles without interference with on-site circulation. Outbound vehicle storage areas shall be provided to eliminate backup and delay of vehicles within the development.

Inbound: The throat shall be of sufficient length to prevent vehicles from spilling onto the street system, and from obstructing the adjacent street, sidewalk, or circulation within the facility.

## Chapter 12. Street Design

This chapter sets the minimum standards for the geometric street section.

### 12.1. Reconstruction

Reconstructed roadways shall be brought up to current standards.

Transitions or tapers necessary to connect with existing roadway of a different width shall meet AASHTO and MUTCD standards.

### 12.2. Widths

Maximum widths for specific streets are provided in Appendix F – Street Matrix.

Typical Lane widths are defined in Table 9.

**Table 10. Typical Lane Widths**

LANE TYPE	WIDTH (ft)
Turning Lane	12
Parking	8
Parking: Bus or Truck Route	10
Inside (Through)	11
Outside (Curb)	12
Bus Only	12
Turn Only	12
Bicycle	5
Bicycle/Vehicle	14

Source: Traffic Management Plan, 2011

### 12.3. Vertical Alignment

Curve length and stopping sight distance shall be designed to ensure proper drainage, clear sight distance, and safety for vehicles and pedestrians.

Maximum profile grade may be exceeded for 300 feet or less, upon showing that no practical alternative exists. Exceptions exceeding 15 percent will require approval by the Fire Marshall.

Grade transitions shall be constructed as smooth vertical curves except in intersections where the difference in grade is one percent or less, and upon approval of the Director.

**Table 11. Maximum Profile Grade**

<i>Maximum Profile Grade</i>				
<i>Local Secondary</i>	<i>Local Primary</i>	<i>Arterial – Collector</i>	<i>Arterial – Minor</i>	<i>Arterial – Principal</i>
<i>15%</i>	<i>10%</i>	<i>10%</i>	<i>10%</i>	<i>9%</i>

## 12.4. Vertical Curve Criteria

The minimum vertical curve for roadways is 75 feet.

The point of vertical curvature shall not encroach into a cross street any further than the center of pavement of the cross street.

Cross Slope: The typical cross slope is two percent crown to provide for adequate drainage to the pavement edge. The maximum cross slope on the tangent sections shall not exceed 4 percent. The minimum cross slope shall be 1 percent.

Stopping Sight Distance (SSD): SSD applies as shown on Table 11 Vertical Curve – Minimum Stopping Sight Distance.

SSD is based on an eye height of 3.5 feet and the height of an object at 0.5 feet.

For downgrades exceeding 3 percent, the SSD shall be increased by the values shown in Table 11.

The Director may approve sag vertical curves on local access streets with stopping sight distance less than that in Table 11, if no practical design exists and if acceptable road lighting is provided throughout the curve.



**Table 12. Vertical Curve – Minimum Stopping Sight Distance**

<i>Design Speed</i>	<i>Flat</i>		<i>Downgrade</i>	
	<i>0%</i>	<i>3%</i>	<i>6%</i>	<i>9%</i>
<i>25</i>	<i>165</i>	<i>165</i>	<i>175</i>	<i>185</i>
<i>30</i>	<i>200</i>	<i>210</i>	<i>220</i>	<i>230</i>
<i>35</i>	<i>250</i>	<i>265</i>	<i>280</i>	<i>305</i>
<i>40</i>	<i>325</i>	<i>345</i>	<i>365</i>	<i>400</i>
<i>45</i>	<i>400</i>	<i>425</i>	<i>455</i>	<i>505</i>

## 12.5. Horizontal Curve Criteria

Superelevation is not required in the design of horizontal curves of local streets, but may be needed to meet terrain and right-of-way conditions.

Calculate superelevation according to AASHTO “Low Speed Urban Streets” design methodology.

See Table 12. Horizontal Curve Design.

**Table 13. Horizontal Curve Design**

<i>Min. Design Speed (mph)</i>	<i>20<sup>1</sup></i>	<i>25<sup>1</sup></i>	<i>30<sup>1</sup></i>	<i>35</i>	<i>40</i>
	<i>Grades &gt;10%</i>				
<i>Center line Radius<sup>2</sup> Minimum (ft)</i>	<i>100</i>	<i>150</i>	<i>300</i>	<i>470</i>	<i>See note<sup>3</sup></i>
<i>Horizontal Sight Distance Minimum (ft)</i>	<i>150</i>	<i>200</i>	<i>200</i>	<i>250</i>	<i>325</i>
<i>Min. Reverse Curve Tangent – Minimum (ft)</i>	<i>0</i>	<i>0</i>	<i>0</i>	<i>200</i>	<i>200</i>
<i>Approach Tangent at Intersections<sup>3, 4</sup> Minimum (ft)</i>	<i>50</i>	<i>75</i>	<i>100</i>	<i>200</i>	<i>300</i>
<i>Tangent between Curves Minimum (ft)</i>		<i>50</i>	<i>50</i>		
<i>Minimum Run-Off Length (ft)</i>		<i>80</i>	<i>90</i>	<i>100</i>	<i>115</i>
<i>Superelevation</i>		<i>Not Required AASHTO Low Speed Urban Streets Design manual.</i>	<i>Not Required AASHTO Low Speed Urban Streets Design manual.</i>	<i>8% Maximum Calculate run-off lengths: AASHTO Low Speed Urban Streets Design Manual</i>	
<i>6% Superelevation Horizontal Curvature Radius (ft)</i>		<i>185</i>	<i>275</i>	<i>380</i>	<i>510</i>
<i>8% Superelevation, Horizontal Curvature for Radius (ft)</i>		<i>170</i>	<i>250</i>	<i>350</i>	<i>465</i>

Source: "Low Speed Urban Streets", AASHTO

1 Use these criteria without superelevation

2 Radii based on crown section with 2% slope on each side of crown

3 Where superelevation is used, calculate runoff lengths according the WSDOT Design Manual.

4 Where a curved road approaches an intersection, these tangent sections must be provided on the approach to the intersection to provide for adequate sight distance for traffic control devices at the intersection. The distance shall be measured from the flow line of the through street. Where superelevation is used, calculate runoff lengths according the WSDOT Design Manual intersection. The distance shall be measured from the flow line of the through street. Where superelevation is used, calculate runoff lengths according the WSDOT Design Manual.

## 12.6. Street End

Streets end in a cul-de-sac, an eyebrow, or a hammerhead – See Standard Plan 209 Street Ends.

Turnaround facilities shall be provided at street ends where the street length from the nearest intersection is more than 150 feet measured from the centerline of intersecting street to end of dead-end street pavement, and shall be constructed as follows:

1. Minimum right-of-way diameter across bulb section: 100 feet in a permanent cul-de-sac; 84 feet in a temporary cul-de-sac, with bulb area lying outside straight-street right-of-way provided as temporary easement pending forward extension of the street
2. Right-of-way may be reduced, provided that utilities and necessary drainage are accommodated on permanent easements within the development.
3. Minimum diameter of surfacing across bulb: 90 feet of paving in curb type road.
4. Cul-de-sac Island: Optional feature for any cul-de-sac. If provided, island shall have full-depth vertical curb. Minimum diameter shall be 20 feet and there shall be at least 30 feet of paved traveled way in a curb type section around the circumference. Island shall be landscaped. The adjoining lot owners shall maintain island through a maintenance agreement.
5. Sidewalks shall be constructed on both sides of the stem and on the bulb

A dead-end local street shall not be longer than 600 feet, measured from centerline of intersecting street to center of cul-de-sac. The maximum length may be extended to 1,000 feet if 50 or fewer potential lots are to be served and there is provision for emergency vehicle turnaround near mid-length

The Director may require an off-street walk or an emergency vehicle access to connect a cul-de-sac at its terminus with other streets, parks, schools, bus stops, or other pedestrian traffic generators, if the need exists. Off-street sidewalks shall be contained in the right-of-way or a sidewalk easement.

If a street temporarily terminated at a property boundary during development serves more than three lots or is longer than 150 feet, a temporary bulb shall be constructed near the plat boundary. The paved bulb shall be 90 feet in diameter with sidewalks terminated at the point where the bulb radius begins. Removal of the temporary cul-de-sac, restoration and

extension of the sidewalk shall be the responsibility of the developer who extends the road.

The maximum cross grade of a street at the street end shall be 8 percent F. Partial bulbs or eyebrows shall have a minimum paved radius and an island configuration. Island shall be offset two feet from edge of traveled way.

A hammerhead per Standard Plan 209 Street Ends may be used to fulfill the requirement to provide a turnaround facility where the street serves (or will serve) four or fewer single-family residential units.

## 12.7. Utility Locations

Utility structures should be located in the amenity zone, at the back of sidewalk without encroaching onto private property, in the gutter line, or within the roadway as specified below.

New utility structures are not allowed in sidewalks, driveways, driveway approaches, or curb ramps.

Underground systems shall be located at least five feet away from road centerline and where they will not otherwise disturb existing survey monuments.

**Table 14. Underground Utility Locations**

<i>Utility</i>	<i>Location From Centerline</i>	<i>Cover</i>	<i>Notes</i>
<i>Water Main<sup>1</sup></i>	<i>Five to ten feet north and east</i>	<i>Minimum 24-inch cover from finished grade, ditch bottom or natural ground.</i>	
<i>Water Service</i>	<i>N/A</i>	<i>Minimum 24-inch cover from finished grade, ditch bottom or natural ground.</i>	<i>For any one connection, not extend more than 60 feet along or through the right-of-way, or the minimum width of the existing right-of-way. Stub out perpendicular</i>

<i>Utility</i>	<i>Location From Centerline</i>	<i>Cover</i>	<i>Notes</i>
			<i>to water main preferred</i>
<i>Water Meter Box</i>	<i>In the right-of-way, at right-of-way line/property line in the one-foot setback between the back of sidewalk and right-of-way line. Not to be located within a driveway.</i>		
<i>Sanitary Main<sup>1, 2</sup></i>	<i>Five feet south and west</i>	<i>Minimum 96-inch cover from finished grade, ditch bottom or natural ground.</i>	<i>Stub out perpendicular to water main preferred</i>
<i>Force Main Side Sewer</i>	<i>Within 10 degrees of perpendicular-to-road centerline, and extend to right-of-way line.</i>	<i>Minimum 36-inch cover from finished grade, ditch bottom or natural ground,</i>	<i>If nonmetallic, install wire or other acceptable proximity detection features; or place in a cast iron or other acceptable metal casing.</i>
<i>Gas Main</i>	<i>Five to ten feet south and west</i>	<i>Minimum 24-inch cover</i>	
<i>Power, telephone, fiber-optic cable, cable TV</i>	<i>Either side</i>	<i>Minimum 36-inch cover</i>	

*1 Sanitary sewer and water lines shall be separated by a minimum of 10 feet in accordance with good engineering practice such as the Criteria for Sewage Work Design, Washington Department of Ecology, and latest edition.*

*2 Gravity systems, whether sanitary or storm drainage, shall have precedence over other systems in planning and installation except where a non-gravity system has already been installed under previous approved permit and subject to applicable provisions of such permits or franchises.*

Electric utilities, power, telephone, fiber-optic cable, cable TV:

Utility poles or other appurtenances shall be located as far from the traveled way or auxiliary lane as conditions allow. No pole or appurtenance shall be located so that it poses a hazard to the general public. Utilities shall place and replace poles with primary consideration given to public safety.

Locations of poles shall be compatible with driveways, intersections, and other road features. A pole shall not interfere with sight distances, road signing, traffic signals, culverts, trees, etc.

Utility poles or other appurtenances shall be located back of ditches, unless an alternate location is approved.

Utility poles should not be placed in sidewalks, curb ramps or landing areas. Utility poles should not impede ADA access in any way.

On roadways having vertical curb, poles and obstacles shall be placed clear of sidewalks. On arterials, poles and obstructions should be placed at least eight and one-half feet from face of curb.

On non-arterial streets, poles and obstructions should be placed at least five and one-half feet from curb face.

Deviations from the pole and obstacle clearance criteria may be requested by utilities when there are no other viable alternatives and must identify adequate protection for motorized and non-motorized users.

## 12.8. Private Streets

Private street design and installation must meet ADA requirements.

See section 12.9 Dead End Street, and Standard Plan 209 Street End.

An access approach shall connect the private street to the public right-of-way.

The private street must be paved at least 20 feet onto the property.

Pedestrian access at least five feet wide shall be provided on at least one side of the private street. The pedestrian access should be separated by a curb or other acceptable delineation. Parking is not permitted in the pedestrian access. Street lighting systems for private streets shall be designed and constructed on a separate power source from the public street systems and shall be the responsibility of the property owner, homeowner, or homeowner's association.

See Table 14 Private Street Dimensions

**Table 15. Private Street Dimensions**

<i>Number of single-family lots</i>	<i>Tract or Easement Width (ft)</i>	<i>Pavement/Traveled Way Width (ft)</i>	<i>Length (ft)</i>
<i>4 or fewer</i>	<i>20</i>	<i>20</i>	<i>150*</i>
<i>More than 4</i>	<i>24</i>	<i>24</i>	<i>150*</i>

\* The dimensions may be adjusted by the Fire Department without a deviation.

## 12.9. Dead End Street

A dead end local street shall not be longer than 600 feet, measured from the centerline of intersecting street to center of cul-de-sac. The maximum length may be extended to 1,000 feet if 50 or fewer potential lots are to be served and there is a provision for emergency vehicle turnaround near mid-length.

Pedestrian access may be required to connect a cul-de-sac to adjacent streets, parks, schools, or other pedestrian facilities. The pedestrian access should be in right-of-way or if approved, may be placed in a sidewalk easement. A turnaround facility shall be provided for a public or private dead end street where the street length is more than 150 feet, measured from the centerline of the intersecting street to the end of the dead-end street pavement.

A dead end street required a cul-de-sac as a turnaround. Cul-de-sacs shall meet the following requirements;

The minimum right-of-way diameter across bulb section is 100 feet for a permanent cul-de-sac or 84 feet for a temporary cul-de-sac.

The minimum diameter of surfacing across the bulb is 90 feet of paving.

## Chapter 13. Intersection Design

The design criteria in this chapter apply to street intersections. Intersections include driveway access as well as an approach to a street.

As much as possible, intersection design shall conform to the guidelines set forth in AASHTO *Policy on Geometric Design*, the ITE *Urban Street Geometric Design Handbook*, and the MUTCD. For state highways, refer to WSDOT design manual(s).

### 13.1. Alignment

The angle of an intersection of two streets shall be 85° to 95°.

The extension of the centerline of each leg of an intersection shall not be offset by more than two feet into the oncoming lane.

### 13.2. Spacing

The minimum distance between adjacent parallel private or local streets shall be 150 feet, measured from nearest curb edge to nearest curb edge. For all other intersections, the spacing shall be determined during preliminary design.

### 13.3. Design Vehicles

Intersections shall be designed to accommodate the design vehicle appropriate for the highest classified street forming the intersection.

The intersection design shall accommodate the use of the roadway as a designated truck route, bus route, or school bus route.

The minimum design vehicle is the SU-30, although use of larger design vehicles may be required depending on roadway classification, transit routes, and adjacent land use.

All elements of the intersection shall be designed so the design vehicle will not encroach onto curbs, sidewalks, traffic control devices, medians, or the travel lanes of opposing travel flow.



## 13.4. Curb Radii

Curb radii design must balance vehicle turning movements with pedestrian safety. Typically, it is appropriate to use the smallest turn radii possible that still accommodates the design vehicle.

For design, round curb radii to the nearest five foot increment.

Typical curb radii based on street classification are shown in Table 15, Typical Curb Radii Design Values. However, these values may be impacted by site conditions, including width of receiving lanes, on-street parking, and angle of intersecting roadways.

**Table 16. Typical Curb Radii Design Values**

Street Classification (for highest street classification at intersection)	Radius
Arterial to Arterial	25 feet
Arterial to Local Street	20 feet
Local Street to Local Street	20 feet
Transit/Truck Route	30 feet
Where vehicular turn is prohibited	10 feet
Radii for curb setbacks and bulb-outs	15/15 feet

## 13.5. Drainage

An intersection shall be laid out and graded so that surface water drains and the intersection is safe and accessible for pedestrians and bicyclists.

Drainage structures shall not be placed in an ADA ramp or landing area.

Ideally, drainage structures should be located outside the corner radii.

Drainage structures should be placed at upstream side to reduce runoff or ponds in ADA ramp area.

## 13.6. Intersection Grades

Intersections shall be on grades as flat as practical.

At an unsignalized intersection, the maximum allowable grade in the intersection is 4 percent extending a minimum of 50 feet in each direction, measured from the outside edge of the traveled way of the intersecting street.

At signalized intersections, the maximum grade is two percent within the intersection and extends 200 feet in each direction. Grades above four percent will be allowed only in areas with steep topography or other unusual circumstances that prevent a flatter grade.

On sloping approaches at an intersection, landings shall be provided with grade not to exceed one foot difference in elevation for a distance of 30 feet approaching an arterial or 20 feet approaching a local street, measured from future right-of-way line (extended) of intersecting street. See Standard Plan 215 Intersection Landing.

The point of vertical curvature shall not encroach into a cross street any further than the center of pavement of the cross street.

### 13.7. Pedestrian Treatments

In order to provide pedestrian safety, accommodations for pedestrians shall be designed into all intersections where pedestrians are expected to be present. Pedestrian accommodations include sidewalks, crosswalks, pedestrian refuge islands, and accommodations for disabled pedestrians.

Vaults, covers, castings, or drainage grates shall not be placed within the crosswalk, or within crosswalk curb ramps or landing areas.

Catch basin and j-box solid covers shall have non-slip covers when placed in sidewalks, pathways, crosswalks, or other pedestrian use areas. The non-slip surface shall be a non-grit, metallic allow surface with a hardness of up to 62 on the Rockwell "C" scale, SlipNot or equal. Diamond or checker plate surfaces are not considered equal. Manhole covers shall have non-slip low profile waffle tread when placed in sidewalks, pathways, crosswalks, or other pedestrian use areas.

Crosswalks (RCW 46.04.160) at intersections are delineated as follows:

Projecting the curb and back of sidewalk lines across the street;

A line 10 feet behind the face of the curb or roadway pavement, when there is no sidewalk; or  
Crosswalk markings.

### Curb Ramps

Consistent with the American with Disabilities Act (ADA), all projects, including alteration or new construction, shall meet ADA requirements and standards.

Curb ramps shall be fully within the crosswalk and shall align with the adjacent crosswalk.

No utility boxes, drainage inlets, signs, and other fixed objects shall be located within the ramp.

The landing at the top of the ramp shall be four feet by five feet and shall be clear of all vertical obstructions.

Utility box lids shall not be located in the ramp portion of a curb ramp.

Utility box lids should not be located in the landing area. In situations where there are no other options, a junction box can be allowed if it is made skid resistant per WSDOT specifications.

Two compliant curb ramps with tactile warning strips should be installed at each corner where possible and corresponding compliant companion ramps shall be retrofitted or constructed (RCW 35.68.075).

When street paving impacts an intersection or modification to a curb ramp occurs, the curb ramps must be retrofitted to meet the current standard. Impact to an intersection is defined as:

Nine square feet or more of disturbance to the sidewalk within the area bounded by the curb, the right-of-way or property lines, and the extensions of right-of-way/property lines (across the sidewalk); or

Three lineal feet of disturbance to the curb.

Development projects requiring installation of frontage improvements; or

Roadway resurfacing defined as an alteration by the 2013 "Department of Justice/

Department of Transportation Joint Technical Assistance on Title II of the Americans with Disabilities Act requirements to provide curb ramps when streets, roads, or highways are altered through resurfacing". This includes asphalt overlays or addition of new asphalt/concrete roadway surface.

## 13.8. Clear Sight Triangle

The following applies to:

1. The intersection of two public streets;
2. The intersection of a commercial driveway with a public street;
3. The intersection of a residential driveway with a public street; and
4. The intersection of a private street with a public street.

Obstructions – Not Allowed.

Intersection other than single-family residential. Sight obstruction is not allowed between two and one-half feet above the street surface and seven and one-half feet above the street surface within the sight triangle established by this section. Sight obstructions above a line seven and one-half feet above the street surface are allowed.

Intersection – single-family residential driveways. Sight obstruction is not allowed between two and one-half feet above the street surface and six feet above the street surface.

Sight obstruction: parked vehicle, signage, fencing, landscaping, or other obstruction installed, set out or maintained, which obstructs the view of motor vehicle operators at an intersection within a clear sight triangle area and between the height limits.

Landscaping, street furniture, marquees, awnings, or other such obstructions must not obscure sight lines to traffic control devices, such as signs or signals.

Obstructions – Allowed.

For minor street/through street intersections (major/minor, signalized, and residential driveways), the following obstructions within the established clear sight areas may be allowed:

1. One obstruction within each sight area which presents a maximum of two and one-half feet width when viewed from the applicable angle, which has at least two feet clear view inside the obstruction (on the side away from the intersection). At distances greater than 40 feet from the viewpoint, the obstruction may present a maximum of four feet width.
2. Any number of obstructions one and one-half feet or less in maximum width when viewed from any applicable angle provided there is equal open space on each side of the obstruction for all angles.

For uncontrolled (no signal or stop signs), yield, and T intersections, the following obstructions within the established clear sight areas may be allowed:

1. One obstruction within each sight area which presents a maximum of eight feet width when viewed from any applicable angle, and which has at least four feet clear view inside the obstruction and eight feet clear view between the obstruction and the edge of the traffic lanes; or
2. Two obstructions within each sight area each of which presents a maximum of five feet width when viewed from any applicable angle, and separated by four feet or more open space when viewed from all applicable angles, and which have at least four feet clear view inside the obstructions and eight feet clear view between the obstructions and the edge of the traffic lanes; or
3. Any number of obstructions one foot or less in width; provided they obstruct no more than two feet continuous obstruction width when viewed from any applicable angle; and provided there is equal open space on each side of the obstruction for all angles.

For intersections not clearly included in the above types and for which view problems may exist, the Director will establish setback lines as required.

Where unusual conditions preclude the application of this subchapter in a reasonable manner, the Director may establish minimum sight distances. These minimum sight distances may be more restrictive than provided herein.

**Residential Driveway.** For the intersection of a residential driveway with a public street, a sight distance triangle for a site access point shall be determined by measuring 15 feet along the street lines and 15 feet along the edges of the driveway beginning at the respective points of intersection. The third side of each triangle shall be a line connecting the end points of the first two sides of each triangle.

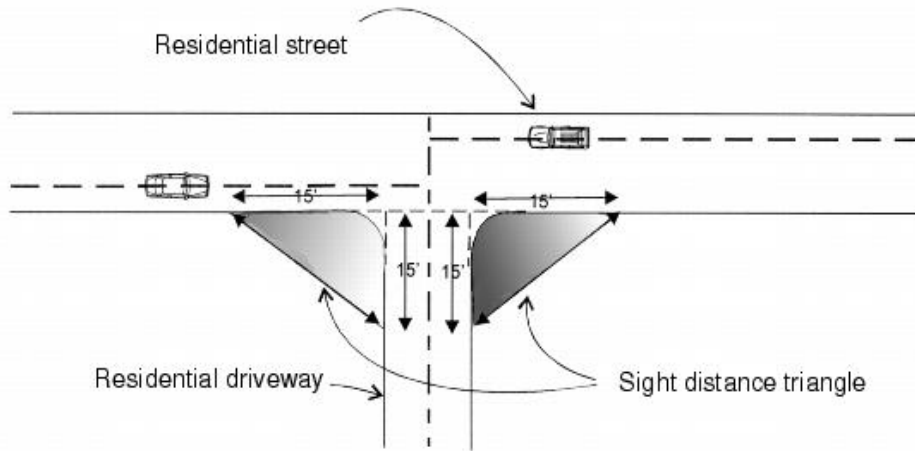

Figure 1. Clear Sight Triangle – Residential Driveway

Uncontrolled Crossing Intersection. For intersections with no traffic control on any approach, the setback lines join a point on the approach located 50 feet back from the center of the intersection with points located 80 feet back from the center of the intersection on the right and left hand streets. All points are on the street centerlines.

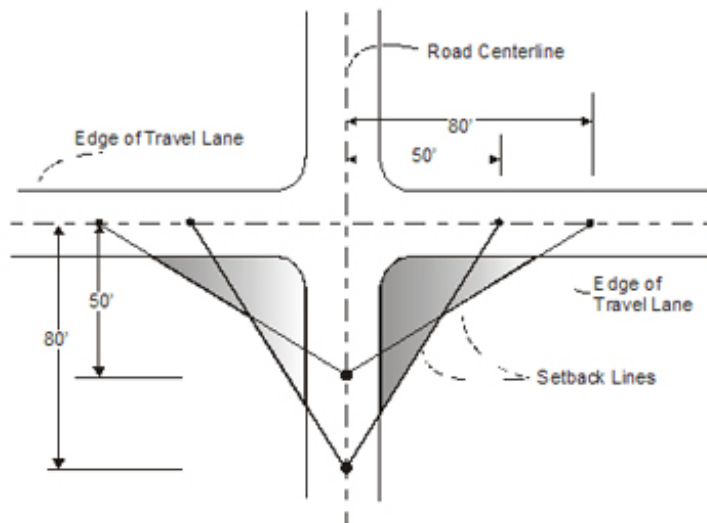

Figure 2. Clear Sight Triangle – Uncontrolled Crossing Intersection

Yield Intersection and T Intersection. Yield intersections have a yield sign on one or both of the minor street approaches, and no control on the major street approaches. The setback lines for yield intersections join a point in the center of the yield approach lane 25 feet back from the edge of the crossing traffic lane with points in the centers of the

crossing approach lanes 100 feet back from the center of the intersection. This setback also applies to a T intersection with no restrictive control; in this case, the 25-foot setback point is on the stem of the T.

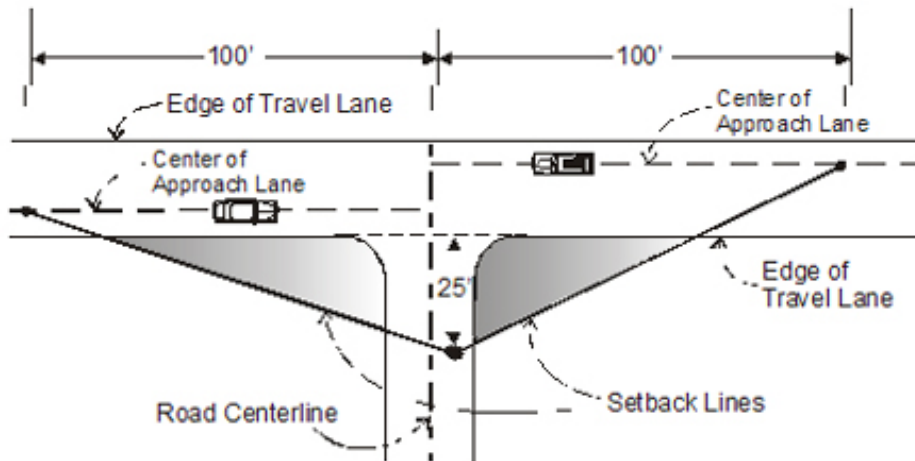

Figure 3. Clear Sight Triangle – Yield and T Intersections

### 13.9. Pedestrian Sight Distance

The minimum sight distance for pedestrian safety shall be determined as follows: the driver of an existing vehicle shall be able to view a one foot-high object 15 feet from either edge of the exit lane at the driveway throat when the driver's eye is 14 feet behind the back of the pedestrian walkway.

The minimum sight distance shall be maintained at all driveways, buildings, and garage entrances where structures, wing walls, etc., are located adjacent to or in close proximity to a pedestrian walkway.

## Chapter 14. Nonmotorized Facilities

### 14.1. General

Nonmotorized facilities may be required by the development code, though transportation impact analysis, by Appendix F Master Street Plan, or other similar means.

Nonmotorized facilities may use developed or underdeveloped right-of-way, or in some circumstances may be located across private property within an easement.

### 14.2. Sidewalks

All designs shall meet the current Americans with Disabilities Act (ADA) requirements and standards. Refer to Chapter 13 Intersection Design for curb ramp requirements.

Sidewalks are required on all streets, except alleys. Sidewalks may be required on private streets and street endings. See Chapter 12, Street Design.

Sidewalks shall be located between the property/right-of-way line and the amenity zone unless otherwise approved by the Public Works Director.

Sidewalks abutting single-family residential uses shall be at least five feet wide.

Sidewalks abutting uses other than single-family residential shall be at least eight feet wide.

The required width of a sidewalk may be greater than eight feet as defined in Appendix F – Master Street Plan or when the City determines that greater widths are warranted due to expected pedestrian traffic volume.

Sidewalks installed immediately adjacent to curb shall have a minimum width of 8' to provide adequate space for signs, fire hydrants, utilities, tree grates and door swing.

Sidewalks should maintain their full width around obstructions that cannot be relocated.



When a sidewalk must transition to frontage that does not have a sidewalk, the transition shall meet ADA requirements. Generally an asphalt transition is acceptable. Refer to Standard Plan 311 Temporary Asphalt Transition Ramp to Shoulder.

Parking stalls shall be designed and constructed so that no part of any parked vehicle obstructs the Pedestrian Access Route as defined by ADA and sidewalk.

Sidewalk shall be constructed with concrete.

### 14.3. Paved Paths

Paved paths can be designated for pedestrian use, bicycle use, or multiuse.

All designs shall meet the current ADA requirements and standards.

Widths for paved paths:

Designated for pedestrian use shall be at least five feet wide and have one-foot wide shoulders on each side.

Designated as two-way bicycle or multi-use path shall be at least ten feet. A minimum of two-foot graded shoulder is required on either side of a paved bicycle path. A wider graded shoulder may be required when heavy pedestrian use is anticipated.

The maximum grade should not exceed 10 percent (5 percent when bicycle use is anticipated). Depending on site conditions, stairs and/or switchbacks may be required. The design engineer should specify treatment to be used on grades greater than 5 percent.

Acceptable surface materials are asphalt concrete (asphalt) and Portland cement concrete (concrete).

### 14.4. Soft-Surface Paths

Soft surface paths are meant for pedestrian use. Such pathways shall be a minimum five feet wide with at least one and one-half foot clearance to obstructions on both sides and at least ten-foot vertical clearance.

All designs shall meet the current Americans with Disabilities Act (ADA) requirements and standards.

Pathways shall be designed and located as to avoid drainage and erosion problems.

Pathways shall be constructed of two and one-half inches of crushed surfacing top course (CSTC) or wood chips over cleared native material as approved by the City.

## 14.5. Bicycle Facilities

Bicycle facilities shall be provided in accordance with the Transportation Master Plan, Appendix F – Master Street Plan and the AASHTO Guide for the Development of New Bicycle Facilities.

Facilities shall be designed for uniformity in design, signage, and pavement markings for bicyclist and motorist safety.

Direction of travel for on-street bicycle facilities shall be in the same direction as the motor vehicle traffic. Unless in facilities such as cycle tracts that are designed to protect bicycle travel.

Veined grates or solid lids shall be used on all catch basins within all bicycle facilities.

Page intentionally left blank.

## Chapter 15. Roadside Features

### 15.1. Fixed Objects

Locate fixed objects so that vehicle and pedestrian sight distance meets the standards in Chapter 13 Intersection Design.

Standard clearances shall be met in accordance with Table 16 Standard Lateral Clearances and Table 17 Standard Vertical Clearances unless approved otherwise to accommodate existing site conditions.

**Table 17. Standard Lateral Clearances**

From	To	Standard Clearance
Curb face	Closest part of any fixed object (excluding traffic control signs and parking meter posts)	2 feet
Textured surface of wheel chair ramp	Closest part of any fixed object	1 foot
Edge of sidewalk	Stair riser	2 feet
Pole face, fire hydrant	Closest part of any fixed object (excluding traffic control signs and parking meter posts)	5 feet

**Table 18. Standard Vertical Clearances**

From	To	Standard Clearance
Roadway surfaces	Any horizontal projection over surface: measured from the crown of the street to the lowest portion of the structure.	16 feet
Sidewalk surfaces	Any horizontal projection over the surface	8 feet
Roadway surfaces	Tree limbs	14 feet
Alley surfaces	Any horizontal projection over paved surface	14 feet
Bicycle path surfaces	Any horizontal projection over surface	10 feet

Electrical Facilities. For projects that trigger installation of or adjustments to Seattle City Light (SCL) facilities, the Applicant coordinates with SCL. Please visit the SCL website or SCL engineering for the most recent information on clearance requirements.

SCL and City staff will work closely with applicants to accomplish appropriate clearances required for design, during construction, and at final build-out. Communication and resolution of required clearances are critical to final design and construction approval of the proposal. Contact Seattle City Light Customer Engineering at [http://www.seattle.gov/transportation/rowmanual/manual/chapter\\_4\\_contact.asp](http://www.seattle.gov/transportation/rowmanual/manual/chapter_4_contact.asp) for more information regarding service requirements.

## 15.2. Landscaping

The following criteria apply to landscaping improvements in the right-of-way. The landscaping design criteria in this section are based on transportation safety requirements and on minimum requirements for plants to achieve mature growth.

For landscaping requirements on private property, please contact a planner in the Planning and Community Development Department. This chapter applies to trees only where noted.

### General

Any right-of-way landscaping disturbed by construction activity shall be replaced or restored.

All landscaping shall meet the sight distance and sight triangle requirements in Chapter 13, Intersection Design.

### Design Requirements

#### Plan

The right-of-way landscaping plan, shall be drawn to an engineering scale, and shall show property lines, plant and tree locations, right-of-way infrastructure, driveways, and intersections, as well as all specifications needed to install and inspect the installation.

Coordinate landscaping with transportation and utility plans. Adjust locations of trees and to accommodate utilities, pedestrians, and sight distance.

Preserve existing trees and landscaping where possible.

#### Plant Selection

All plants shall conform to American Association of Nurserymen (AAN) grades and standards as published in the “American Standard for Nursery Stock” manual, provided that existing healthy vegetation used to augment new plantings shall not be required to meet these standards.

Plant selection shall consider adaptability to climatic, geology, and topographic conditions of the site.

New trees must be at least two-inch caliper and selected from the City-approved street tree list in Appendix G.

Mature tree and shrub canopies may not reach an above ground utility such as street lights and power lines.

#### Soil

The landscaping plan shall provide soil specifications, including soil depths. Refer to BMP T5.13 Post Construction Soil Quality and Depth (Stormwater Manual) for general soil specifications. Improvements that include biofiltration require specific specifications for the soils.

### 15.3. Mailboxes

United States Postal Service (USPS) must approve all mailbox locations.

Clustered mail boxes are preferred.

The approach to mailboxes must be clear of obstruction.

Refer to Standard Plans 514 Mailbox Stand non-Arterial and 515 Mailbox Stand w/o Amenity Zone.

### 15.4. Steps

Steps and stairways, and associated landings from private property shall not extend into the right-of-way.

Stairways in public rights-of-way shall be designed and constructed according to Standard Plans 325 Stairs and 326 Cement Concrete Stairway.

The first riser shall be at least two feet clear of a public walk.

A minimum five feet by five feet landing shall be provided after each 20 risers.

Pedestrian lighting may be required for stairways.

## 15.5. Railing

Railings on private property must be consistent with guard requirements of the adopted building codes. They shall have a maximum spacing of four inches for vertical elements of the railing.

Railings in the right-of-way shall be consistent with Standard Plans 324 Pedestrian Railing, and the WSDOT Standard Specifications.

Railing in the right-of-way shall be installed along a nonmotorized transportation facility when there is a drop from the facility of 30 inches or more and:

The vertical wall face is less than 4 feet in horizontal distance from the near side face of the facility. See Case A.

The vertical wall face is greater than four feet horizontally to the near side face of the facility and the slope to the wall top is steeper than 1V:3H. See Case B.

The slopes adjacent to the facility average greater than 1V:2H. See Case Handrails shall be designed in accordance with Standard Plans 323 Hand Rails and 324 Public Right-of-way Hand/Guardrail, and the WSDOT Standard Specifications.

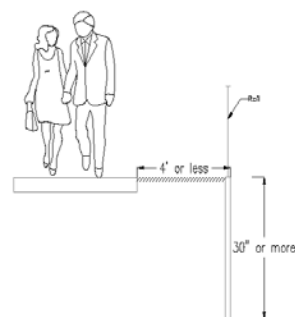
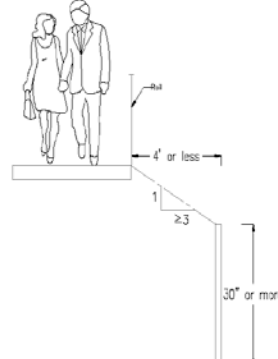
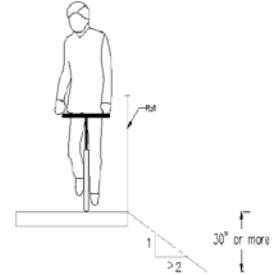
		
<b>CASE A</b>	<b>CASE B</b>	<b>CASE C</b>

## 15.6. Cut-and-fill Slopes

Side slopes shall be 2H:1V or flatter on both fill slopes and cut slopes.

Steeper slopes may be approved by the Director when supported by a geotechnical report and engineering recommendations.

Side slopes shall be stabilized by grass sod or seed, or by other approved plant or surface materials.

## 15.7. Guardrail

Guardrail shall be provided and installed by the developer as directed by the Director. For purposes of warrants, design, and location, all guardrails along public and private roadways shall conform to the criteria of the WSDOT Standard Plans and Specifications.



Page intentionally left blank.

## Chapter 16. Surface Treatment

This chapter provides criteria for paving and for restoring travelled ways within the City's right-of-way.

### 16.1. General

Hard surfacing such as asphalt concrete or Portland concrete cement (PCC) is required within the right-of-way.

Gravel surfacing may be allowed in rights-of-way that the City does not maintain, such as alleys.

Grades steeper than 20 percent (when approved) must be paved with PCC.

Use of permeable pavements in the right-of-way requires review and approval by the Director.

### 16.2. Asphalt Pavement Design

#### Arterial Streets

Any pavement for arterial streets shall consider the load bearing capacity of the soils, based on actual field tests, and the traffic-carrying requirements of the roadway.

The analysis shall include the traffic volume and axle loading, the type and thickness of roadway materials and the recommended method of placement. Pavement sections shall not be less than those required for collector arterials.

Pavement design must be prepared by an engineer licensed in Washington State who is proficient in pavement design. Soils tests are required to assess the California Bearing Ratio (CBR) for the subgrade.

#### Non-arterial Streets

Minimum asphalt pavement sections are identified in Standard Plan 201 Typical Local Street as:

Surfacing: two inches Class B Asphalt Concrete

Base: four inches Asphalt Treated Base over two inches Crushed Surfacing Top Course

In areas of pavement restoration or adjacent to existing pavement, reconstruction shall at a minimum match existing roadway sections, unless otherwise approved.

#### Poor Subgrade

The minimum material thicknesses indicated are not acceptable if there is any evidence of instability in the subgrade. This includes free water, swamp conditions, fine-grained or organic soil, slides, or uneven settlement. If there are any of these characteristics, the soil shall be sampled and tested sufficiently to establish a pavement design that will support the proposed construction. Any deficiencies, including an R-value of less than 55 or a CBR of less than 20, shall be fully considered and compensated for in the design.

### 16.3. Pavement Widening

Any widening of an existing roadway, either to add traveled way or paved shoulder, shall have the same surfacing material as the existing roadway.

When an existing shoulder is to become part of a proposed traveled way, a pavement evaluation shall be performed. The shoulder area shall match the existing roadway section or pavement design is required to determine if the shoulder is acceptable or if any improvements are necessary. Designs based on these evaluations are subject to review and approval by the Director. The responsibility for any shoulder material thickness improvement shall be considered part of the requirement for roadway widening.

## Chapter 17. Traffic Control Devices

All traffic control devices shall conform to the MUTCD and City of Shoreline standards

All signs, such as street name, parking, stop, dead end, speed limit, and non-motorized indicators shall be approved as part of the project plan. The channelization plan showing paving markings, permanent signing, and crosswalk locations shall be prepared by a licensed engineer.

Temporary traffic control to ensure traffic safety during construction activities shall be provided by the developer and installed per MUTCD standards, or as directed by the Inspector.

### 17.1. Traffic Signals

The following apply to new or modified traffic signals.

A signal warrant study prepared by a licensed engineer shall be required for all new traffic signal installations. The study shall be approved by the City Traffic Engineer.

Signal design shall meet ADA and MUTCD requirements.

Emergency vehicle preemptions systems are required for all new signal installations and may be required for signal modifications.

Signal structures consisting of poles and mast arms will be required for all new installations.

Stop bar and advanced loop detection is required for all signalized approach lanes per Standard Plan 420. Camera detection may be installed by request and as reviewed and approved by the City Traffic Engineer.

Transit Signal Priority capability may be required at intersections which serve transit routes.

Bicycle loop detection is required for all bicycle lane approaches to signalized intersections. If a predominant left turning movement for bicyclists is present, bicycle push buttons or channelized bike boxes may be required.

All new signals require back up battery systems. New signals shall provide communication to the City's Central System when feasible.

Traffic signal equipment including cabinets, controllers and other components will be reviewed and approved by the City Traffic Engineer.

Page intentionally left blank.

# DIVISION 3 – SURFACE WATER

Page intentionally left blank.



## Chapter 18. Surface Water Standards

Division 3 – Surface Water applies to public and private development within the City.

The City of Shoreline has adopted the 2014 Department of Ecology Stormwater Management Manual for Western Washington (Stormwater Manual) and, for general guidance, refers to the 2012 Low Impact Technical Guidance Manual for Puget Sound (LID Manual).

A. For surface water design:

1. *2012 Stormwater Manual for Western Washington, as Amended in December 2014* (Stormwater Manual), Department of Ecology. Shoreline’s modifications to the Stormwater Manual are itemized in Chapter 18 Stormwater Manual Modifications. The Stormwater Manual is available on the Department of Ecology website:  
<http://www.ecy.wa.gov/programs/wq/stormwater/manual.html>
2. The 2012 *Low Impact Technical Guidance Manual for Puget Sound* (LID Manual) may be used for guidance on LID site design. The LID Manual is available on the Puget Sound Action Team website:  
[http://www.psp.wa.gov/downloads/LID/20121221\\_LIDmanual\\_FINAL\\_secure.pdf](http://www.psp.wa.gov/downloads/LID/20121221_LIDmanual_FINAL_secure.pdf)

B. For conveyance system design in the City:

3. King County *Surface Water Design Manual*, latest edition, Chapter 4 “Conveyance System Analysis and Design”. Refer to EDM Table 20, Conveyance System Specifications, for the City’s amendment to Chapter 4. The manual is available online at:  
<http://www.kingcounty.gov/environment/waterandland/stormwater/documents/surface-water-design-manual>
4. Supporting information can be found in the 2016 King County *Road Standards* online at:  
<http://www.kingcounty.gov/depts/transportation/roads/road-standards.aspx#2016>

Page intentionally left blank.

## Chapter 19. Stormwater Manual Modifications

The chapter lists the City's amendments to the Stormwater Manual. When using the Manual, assume there is no amendment unless it is listed in this chapter. When the Stormwater Manual states something is "optional" or "up to the jurisdiction," it is a requirement in Shoreline, unless otherwise noted herein.

---

### A. Modifications to 2.3 – Definitions Related to Minimum Requirements

City definitions shall be used where applicable. Refer to Appendix A – Acronyms and Definitions and applicable Shoreline Municipal Codes.

### B. Modifications to 2.4 – Applicability of Minimum Requirements

#### Section 2.4.2 – Redevelopment

1. The paragraph below replaces the fourth paragraph, beginning with "The local government may allow the Minimum Requirements to be met for an equivalent (flow and pollution characteristics) area within the same site..." of section 2.4.2.
  - a. When in the same threshold discharge area, surface water control requirements for proposed impervious areas may be applied to equivalent existing developed areas of the site, provided those areas have equivalent flow and pollution characteristics and do not already have such controls.
2. Supplemental Guidelines is revised. The second paragraph states, "Local governments can select from various bases for identifying projects that must retrofit the replaced hard surfaces on the project site."
  - a. City of Shoreline elects to require retrofit for replaced hard surfaces not separated from other runoff when the value of the improvements (excluding land value) exceeds 50 percent of the assessed value of the existing improvements (excluding land value).
3. Where the 2014 SWMMWW states that "Local governments are allowed to institute a stop-loss provision on the application of stormwater requirements to replaced hard surfaces", The City of Shoreline has determined that Stop Loss does not apply.

4. Where the 2014 SWMMWW states that “Local governments can also establish criteria for allowing redevelopment projects to pay a fee in lieu of constructing water quality or flow control facilities on a redeveloped site”, the City of Shoreline has determined that the fee-in-lieu does not apply.

#### C. Modifications to 2.5 – Minimum Requirements

##### Section 2.5.1 – Minimum Requirement #1, Preparation of Stormwater Site Plans

No modifications. Refer to the Stormwater Manual Vol I: 2.5.1.

##### Section 2.5.2 – Minimum Requirement #2, Construction Stormwater Pollution Prevention Plan (SWPPP) Elements. Refer to Chapter 24, Stormwater Pollution Prevention Plan for additional information.

(The following amendments also apply to Vol. II Construction Stormwater Pollution Prevention, Element #2)

#### Element 2 – Establish Construction Access

1. Street washing is not permitted, even after shoveling or sweeping.
  - a. During construction, if material is being deposited on off-site streets, additional strategies may be required including:
    1. Regenerative-type vacuum sweepers and repeated or continuous sweeping.
    2. Wheel wash (or an improved wheel wash if one already exists).
    3. Special site procedures and provisions (such as transferring haul-outs to trucks that travel only on paved and maintained surfaces in the site).
    4. Suspension of work until dry weather.
2. Element 4 – Install Sediment Controls
  - a. If the standards are not being met, additional BMPs (including site-specific designs) shall be implemented. If additional BMPs are not implemented or are not successful, work may be suspended until the City approves a new SWPPP (see Vol. II: 2.3).
  - b. Element 5 – Stabilize Soils

1. Rainy season requirements are required October 1 through April 30. A Seasonal Suspension Plan is required for some projects having 11,000 SF or more of disturbed land. Refer to Element 12, Manage the Project, for more information. All projects must implement BMP T5.13 Post Construction Soil Quality and Depth.

c. Element 6 – Protect Slopes

1. Clearing/grading work shall comply with the Stormwater Manual, geotechnical recommendations, SEPA (State Environmental Policy Act) conditions, and other applicable regulations and standards. These project-specific requirements are in addition to and take priority over general standards.

d. Element 7 – Protect Drain Inlets

1. The Contractor shall remove inlet protection at the end of the project without releasing captured sediment into the storm system.

e. Element 8 – Stabilize Channels and Outlets

1. Temporary conveyance channels shall be stabilized for the 10-year, 24-hour frequency storm, and assuming full build out of tributary area(s).

f. Element 12 – Manage the Project

1. For Certified Erosion and Sediment Control Lead (CESCL) requirements, and Rainy Season Requirements and Seasonal Suspension Plan, refer to Chapter 24, Stormwater Pollution Prevention Plan.

g. Element 13 – Protect LID BMPs

1. If the standards are not being met, additional BMPs (including site-specific designs) shall be implemented. If additional BMPs are not implemented or are not successful, work may be suspended until the City approves a new SWPPP.

h. Additional requirements for all projects:

1. Dust is controlled and is in compliance with the Puget Sound Clean Air Agency; and
2. Work in Critical Areas conforms to requirements of the City's Critical Areas Ordinance (CAO).

3. 2.5.3 – Minimum Requirement #3, Source Control of Pollution

No Modifications. Refer to the Stormwater Manual Vol. I: 2.5.3.

4. 2.5.4 – Minimum Requirement #4, Preservation of Natural Drainage Systems and Outfalls

No Modifications. Refer to the Stormwater Manual Vol. I: 2.5.4.

5. 2.5.5 – Minimum Requirement #5, On-site Stormwater Management.

Refer to the Stormwater Manual Vol. I: 2.5.5.

- a. Projects using List #1 must consider Rain Gardens or Bioretention before considering Permeable Pavement for other hard surfaces.
- b. Projects that use infiltration to meet Minimum Requirement #5 also must refer to Chapter 21 of this Manual.

6. 2.5.6 – Minimum Requirement #6, Runoff Treatment

- a. Treatment requirements shall not be less than that achieved by facilities in the Enhanced Treatment Menu (see Vol. V, Chapter 3).

7. 2.5.7 – Minimum Requirement #7, Flow Control

- a. On projects that do not have set building footprints, for example a site development permit for a short plat, the flow control modeling shall use maximum hardscape allowed in the applicable zoning designation as the maximum impervious surface at full build out. Refer to SMC Chapter 20.50. For example, if a zoning designation allows maximum 50 percent of a lot as hardscape, then 50 percent is the maximum impervious surface to use for flow control modeling at full build-out.
- b. Direct Discharge Exemption: the Director may approve an exemption to flow control for projects that discharge to Puget Sound or to Lake Washington, provided the proposal includes analysis showing that the existing or proposed conveyance system meets all the requirements in the Stormwater Manual for direct discharge, and: 1) the system conveys the 50-year frequency peak event for the entire basin without surcharging catch basins above the catch basin rim; and 2) the 50-year frequency

event does not flood proposed buildings or any existing on-site or off-site buildings.

1. The analysis shall consider full build-out conditions, based on current zoning using the direct discharge option for flow control for those parcels that drain to the conveyance system. The analysis shall consider both conveyance impacts to the system down gradient of the proposed project and also the project's backwater impact to upstream and lateral flood stages in the conveyance system.

c. Where the Standard Flow Control Requirement is applicable in Boeing Creek watersheds, projects shall model the pre-developed condition as the "historic" land cover condition. The criterion allowing the use of existing land cover condition in basins that have been 40% total impervious area since 1985 is not permitted.

8. 2.5.8 – Minimum Requirement #8, Wetlands Protection

No Modification. Refer to the Stormwater Manual Vol I: 2.5.8

9. 2.5.9– Minimum Requirement #9, Operation and Maintenance

Applies with the following modifications:

a. The operations and maintenance manual (O&M Manual) shall include provisions for maintenance of BMPs and facilities in perpetuity. The manual and all exhibits shall meet the requirements for recording set by the King County Recorder's Office. The final O&M manual shall be submitted for review and approval before it is recorded with the King County Recorder's Office.

b. For public facilities built by private development:

A copy of the draft operations and maintenance manual shall be submitted with the permit submittal. The final O&M Manual shall be submitted for review and approval prior to acceptance of the completed construction project. The final approved O&M Manual shall be submitted with one hard copy and one electronic copy on CD.

c. For private facilities:

Before final permit approval, the Permittee shall submit the recording number to the City.

d. At a minimum, the O&M Manual shall include:

1. Party/parties responsible for facility maintenance, including phone numbers and addresses;
2. For subdivision, list lots whose owners will be responsible for maintenance;
3. Maintenance cost distribution for shared stormwater best management practices and drainage facilities;
4. Site map showing BMPs, critical area(s), buildings, affected lots, and dimensions;
5. A list of BMPs and facilities installed on-site and purpose of each;
6. For each BMP or facility, the required maintenance activities and schedule meeting the minimum requirements given in the Stormwater Manual Vol. V: Chapter 4;
7. List of any proprietary components along with vendor's contact information and the vendor's maintenance schedule and costs;
8. Inspection and maintenance schedules including recommended maintenance schedules per vendor specifications for proprietary components;
9. Care and maintenance of any powered devices (e.g. pumps, aeration);
10. Inspection procedures and how the maintenance schedule will be modified if inspections determine the facility is not operating properly;

The final O&M manual shall incorporate any comments made during the development review process, and shall incorporate any field changes made to the facilities during construction.

e. Modifications to 2.6 – Optional Guidance



a 2.6.1 – Optional Guidance #1, Financial Liability

EDM Division 1 provides requirements for Financial Guarantee information for work performed within the right-of-way.

b 2.6.2 – Optional Guidance #2, Off-Site Analysis and Mitigation

Preliminary analysis shall be qualitative. Refer to the Stormwater Manual Vol. I: 3.1.3. The City may require quantitative analysis and mitigation based on the results of the downstream analysis.

Page intentionally left blank.

## Chapter 20. General Requirements

### 20.1. Licensed Professionals

- A. State law requires engineering work be performed by or under the direction of a professional engineer licensed to practice in Washington State. Plans involving construction of treatment facilities or flow control facilities, structural source control BMPs or drainage conveyance systems generally involve engineering principles and should be prepared by or under the direction of a licensed engineer.
- B. Construction Stormwater Pollution Prevention Plans (SWPPPs) that involve engineering calculations must also be prepared by or under the direction of a licensed engineer.
- C. Infiltration testing must be performed by a licensed professional. Refer to Chapter 21, Infiltration, or the Stormwater Manual Vol. III: Chapter 3.3.6.
- D. Depending on project scope and location characteristics, the Director may require a licensed professional for any project. All credentials shall be current and issued by Washington State.
- E. A Washington State licensed civil engineer with geotechnical expertise is required for site assessment for site work within or adjacent to slopes steeper than 15 percent and higher than 10 feet.
- F. In addition to Department of Ecology NPDES Construction General Permit requirements, a Certified Erosion and Sediment Control Lead (CESCL) must be designated for projects proposing site work during the rainy season (October 1 through April 30) and clearing more the 7,000 SF or 65 percent of the site. The Director may require a designated CESCL when there will be disturbance on a site that contains or abuts a critical area. Refer to the Stormwater Manual Vol. II: Chapter 4, BMP C160: Certified Erosion and Sediment Control Lead.
- G. Shoreline prefers planting plans and specifications to be prepared by a licensed Landscape Architect or a qualified professional working in the field of landscape design or horticulture.

### 20.2. Grading

Any grading activity, whether or not it requires a permit, must prevent soils leaving the site or entering drainage facilities, streets and roads, water resources, or adjacent properties.

### 20.3. Special Drainage Areas

No special drainage areas have been designated with additional drainage restrictions.

## 20.4. Water Quality Restrictions

- A. The City does not have currently designated or known aquifers, or wellhead protection areas.
- B. The Lake Ballinger Watershed, which includes the Echo Lake sub-basin, currently has a TMDL for phosphorous.
- C. Enhanced treatment is the minimum water quality treatment standard when water quality treatment is triggered by the Stormwater Manual.

## 20.5. Separated Runoff

- A. Sanitary sewer facilities shall be separate from storm water facilities.
- B. Project design must keep runoff from public rights-of-way separate from on-site surface water runoff. Surface water controls for one private property shall not be placed in public right-of-way or on other public property.
- C. Runoff from replaced impervious surfaces that is not separated from other runoff may trigger a retrofit of the on-site storm drainage system in accordance with the Stormwater Manual Vol. I: 2.4.2, and Chapter 19, Stormwater Manual Modifications for retrofit triggers.

## 20.6. Backflow Prevention

The City may require backflow prevention on private stormwater connections to City-owned stormwater trunk lines or to undersized stormwater mains.

## 20.7. Sump Pumps

Uncontaminated discharge from sump pumps may connect to the City's surface water system when approved by a permit.

## 20.8. Footing Drains

For single-family residences, footing drains may connect to the downspouts, on the property, at a covered catch basin that is located no closer than five feet to the foundation. Care must be taken to ensure that slopes will carry the water away from the building during high flows.

## 20.9. Catch Basin Medallions

Surface water education medallions shall be installed at all existing and new catch basins installed on-site or within the adjacent right-of-way. The City provides the medallions and installation instructions at no cost when requested.

## 20.10. Maintenance Access

- A. All storm water facilities shall be accessible to maintenance vehicles, unless specifically waived by the City. If not located in or adjacent to an existing accessible access, an improved roadway surface shall be provided.
- B. Access roads shall be designed with 40 foot inside radius on curves, grades flatter than 15 percent, and at least 10 feet wide. The access must be designed to carry H2O loading. The approved surfaces include asphalt concrete, cement concrete, pervious concrete, pervious asphalt, structurally stabilized vegetated surface, or crushed surfacing.
- C. The City may require the maintenance access be located in a separate tract.
- D. A stormwater covenant or easement shall be required for all privately constructed storm facilities.

## 20.11. Offsite Drainage Improvements

With the City's approval, the Applicant may provide offsite improvements in the same drainage basin or threshold discharge area to mitigate water quality and flow control requirements associated with the project. These offsite improvements shall provide equivalent water quality and flow control.

## 20.12. Watercourses

- A. Streams should be preserved in their existing channels.
- B. Any alteration to a stream channel, piped water course or associated set-back areas requires approval by the Washington Department of Ecology (DOE) and the Washington State Department of Fish and Wildlife (WDFW).
- C. A copy of the WDFW approval must be submitted prior to permit issuance.
- D. SMC 20.80 contains additional requirements for critical areas.
- E.

## 20.13. Stormwater Facility Operation

All Private Stormwater Facilities installed to meet Minimum Requirements #5, #6, and #7 (per the Stormwater Manual) are subject to inspection and must be maintained to the standards set forth in SMC Chapter 20.70.

## 20.14. Subdivisions

- A. The maximum hardscape in the Development Code (SMC Chapter 20.50) is used to determine impervious area for surface water design. When the maximum hard surfaces are not known, such as a project where full build out could occur over years, use this code to estimate maximum hard surfaces.
- B. Construction of the lot drainage connection systems must be feasible and allow connection to the proposed formal and short subdivision improvements or to the documented infiltration areas.
- C. When a subdivision surface water plan includes piped connections, provide a connection stub to each lot. A maximum of three lots may be connected to a common private collection pipe, six inches or more in diameter. For subdivisions, no more than three (3) roof drain stubs are allowed on a single roof drain collection pipe.
- D. Roof and footing drain connection stubs shall be at least one foot below the lowest existing elevation of the building envelope on all newly created lots, unless a different elevation is approved or required by the City.
- E. Easements for the specific drainage systems shown on the site development documents must be provided as part of the formal or short subdivision.
- F. Where the surface water plan and flow control calculations for a subdivision include assumptions about the size, location, or performance of permeable pavement, rain gardens, or bioretention facilities on individual lots, the surface water plan and site development plan shall identify the obligation of each lot. The Applicant shall record a deed restriction against each lot for the construction and maintenance of those facilities by subsequent owners.

## 20.15. Phased Projects

- A. For projects that will be built in phases, the Applicant must provide plans that show the overall project as well as the project phases. The plan shall clearly delineate phase boundaries and provide estimates for construction dates for the phases.

- B. The Applicant shall consider all phases when calculating thresholds for stormwater management. Phasing of projects shall not result in a reduction of drainage and erosion control requirements.

## 20.16. Protect Vegetation Post Construction

- A. Mechanisms shall be put in place to assure long-term protection of vegetation retention areas. Mechanisms to protect conservation areas include setting aside conservation areas into separate tracts, permanent easements, homeowner covenants, maintenance agreements, and education.
- B. Permanent signs shall be installed indicating that removal of trees or vegetation is prohibited within a native vegetation retention area.
- C. Permanent fencing is required around the limits of any native vegetation retention area. The type, size, and location of the fencing shall be approved by City review staff and should be made of materials that blend in with the natural surroundings. For example, wood split-rail, pinned if necessary, and located in such a manner as to not impede the movement of wildlife within the vegetation retention areas.

## Chapter 21. Infiltration

Infiltration is a basic technique for many Low Impact Development practices to meet Minimum Requirement #5 and can be used to meet Minimum Requirement #7, Flow Control. Infiltration best management practices provide many benefits; therefore, the City of Shoreline requires infiltration facilities for sites where conditions are appropriate.

### 21.1. Soils and Subsurface Investigation

Use of infiltration is applicable on sites with appropriate site, soil, and subsurface conditions. Investigation of soil and subsurface characteristics of the site is required for all projects proposing to use infiltration.

Medium Impact Projects shall investigate and submit reports as described in section A, below. Large Impact Projects shall investigate and submit reports as described in the Stormwater Manual; Section B, below, provides a helpful roadmap to the location of requirements in the Stormwater Manual.

#### A. Medium Impact Projects

A Medium Impact Project as defined in Chapter 22, Surface Water Project Classifications, shall provide the following reports and analyses for soils and subsurface investigations to meet Minimum Requirement #5.

#### B. Soils Report

A Soils Report prepared by a professional soil scientist certified by the Soil Science Society of America (or an equivalent national program), a locally licensed on-site sewage designer, or by other suitably trained persons working under the supervision of a professional engineer, geologist, hydrogeologist, or engineering geologist registered in the State of Washington is required. The report shall identify:

1. For all sites, the Soils Report must include a description of the soils on the site using soil surveys, soil test pits, soil borings, or soil grain analyses (see <http://websoilsurvey.nrcs.usda.gov/app/HomePage.htm> for soil survey information). The report shall establish the type and limit of soils on the project site and include an inventory of topsoil depth.



2. For sites proposing to meet Minimum Requirement #5 solely with downspout full infiltration, the following additional site-specific information is required:
  - a. Document the presence of outwash or loam soils at the location of the downspout infiltration drywell or trench using at least one soil log a minimum four feet deep from proposed grade and one foot below expected bottom elevation of trench. Identify the NRCS series of the soil and the USDA textural class of the soil horizon through the depth of the log, and note any evidence of high groundwater level.
  - b. Document at least three feet of outwash or loam soils from the proposed final grade to the seasonal high groundwater table, at least one foot of clearance from expected bottom elevation of trench or drywell to seasonal high groundwater table.
3. For sites proposing to use Permeable Pavement for a pollution-generating surface (driveway, parking area, street), document the soil's physical and chemical suitability for treatment [Note: where soils do not meet the criteria, permeable pavement is infeasible.] Soils must meet all three of the following criteria:
  - a. Cation exchange capacity (CEC) is  $\geq 5$  milliequivalents CEC/100 g dry soil (USEPA Method 9081).
  - b. Organic content is  $\geq 1\%$  (ASTM D 2974).
  - c. One foot depth of soil below base of permeable pavement has the above characteristics.

#### C. Infiltration Testing

Projects proposing to meet Minimum Requirement #5 with rain gardens, bioretention, or permeable pavement must demonstrate adequate infiltration and separation from groundwater or hydraulic restriction layer.

The Soils Report shall include infiltration testing conducted by a professional soil scientist certified by the Soil Science Society of America (or an equivalent national program), a locally licensed on-site sewage designer, or by other suitably trained persons working under the

supervision of a professional engineer, geologist, hydrogeologist, or engineering geologist registered in the State of Washington. At each location where a rain garden, bioretention, or permeable pavement is proposed, the following are required:

1. At each location, determine the initial (uncorrected) infiltration rate using one of the methods described in Appendix H:
  - a. On sites with outwash soils (unconsolidated by glacial advance), use grain size analysis; or
  - b. A small-scale Pilot Infiltration Tests (PIT) conducted between December 1 and April 1 (inclusive). (Fewer tests may be needed if the certified soils professional confirms that the site is unconsolidated outwash soils and at least one foot to groundwater exists under the proposed bottom of the facility.)
2. At each location, report the design infiltration rate using correction factors described in Appendix H.
3. At each location, determine the depth to any hydraulic restriction layer (ground water, impermeable soil, bedrock, etc). These test must be performed between December 21 and March 21 (inclusive):
  - a. Excavating a pit at least one foot below the proposed bottom elevation of the rain garden/bioretention or below the subgrade surface of a permeable pavement; or
  - b. Testing with a monitoring well to a depth at least one foot below the estimated bottom elevation of a rain garden/bioretention excavation and at least one foot below the subgrade surface of a permeable pavement.

#### D. Large Impact Projects

A Large Impact Project as defined in Chapter 22, Surface Water Project Classifications, shall conduct a detailed soils and subsurface evaluation. Requirements are given in the Stormwater Manual. Table 19 below provides cross-references to soils and subsurface investigation requirements for Large Impact Projects to meet Minimum Requirement #5 and when infiltration is

proposed to meet Minimum Requirement #7. Infiltration is the preferred method for meeting Minimum Requirement #7.

**Table 19.** Large Impact Projects Soil and Subsurface Investigation Requirements

Requirement	Facility Type	Reference
Soils Report	All	Stormwater Manual, Volume I, Section 3.1.1 – the soils report is described under the requirement for a site analysis for projects required to meet Minimum Requirements # 1-9
Site and Subsurface Characterization	Downspout Full Infiltration	See Section A.1.ii, above.
	Bioretention and Permeable Pavement (MR #5 or #7)	Stormwater Manual, Volume III, Section 3.4
	Infiltration Basin/Pond, Trench, Vault, Tank (MR #7, also for MR #5 on sites that elect to meet LID Performance Standard)	Stormwater Manual, Volume III, Sections 3.3.5, 3.3.6, and 3.3.7

## 21.2. Prohibitions

Infiltration facilities are prohibited under the following conditions:

- A. If the measured (initial) infiltration rate is less than 0.3 inches per hour, bioretention and permeable pavement are not approved to meet LID requirements (Minimum Requirement #5).
- B. If design infiltration rate (after application of correction factor) is less than 0.3 inches per hour, infiltration facilities are not approved means to meet flow control (Minimum Requirement #7) or water quality treatment (Minimum Requirement #6) requirements.
- C. Infiltration is not permitted within a Landslide Hazard Area as defined by SMC Chapter 20.80 Critical Areas or within a setback above a Landslide Hazard Area as described in SMC Chapter 20.80. **Note:** Other critical areas may have infiltration restrictions.

D. Infiltration in the right-of-way of arterial streets and/or areas of dense underground infrastructure is restricted. The infiltration facility must be hydraulically separated from the street subgrade and physically separated from vehicular traffic.

### 21.3. Horizontal Setbacks

Setbacks are measured from the maximum pond elevation before overflow. Bioretention setbacks are measured from the bottom edge of the bioretention soil mix.

Setbacks do not replace infeasibility criteria for bioretention and permeable pavement. Applicants using the List Approach to meet Minimum Requirement #5 must use the infeasibility criteria in the Stormwater Manual to determine if bioretention or permeable pavement may be considered infeasible on the site. If bioretention or permeable pavement are feasible, then setbacks must be observed.

Unless otherwise noted, the following setbacks do not apply to permeable pavement surfaces that do not manage runoff from other areas.

- A. Infiltration is not permitted within five feet of property lines (excluding the property line abutting the right-of-way) without agreement from neighboring property owners.
- B. Infiltration is not permitted within the following setbacks from on-site and offsite structures:
  - 1 When runoff from <5,000 SF of impervious area is infiltrated in a single facility, the facility shall be located at least five feet from a structure without basement and 10 feet from a structure with basement.
  - 2 When runoff from  $\geq 5,000$  SF of impervious area is infiltrated in a single facility, a building structure shall not intersect with a 1H:1V slope from the bottom edge of an infiltration facility. The resulting setback shall be no less than five feet from a structure without basement and 10 feet from a structure with basement. For setbacks from structures on adjacent lots, future build-out conditions should be considered.
  - 3 No setback from site structure is required if open draining crawl space or system is approved by geotechnical engineer.

Infiltration is not permitted within 100 feet of drinking water supply wells or springs used for drinking water. This setback applies to permeable pavement that is a pollution-generating surface.

- C. Infiltration is not permitted within a groundwater protection area unless approved by the Director. If approved, water quality treatment may be required.
- D. Infiltration is not permitted within 10 feet of underground storage tanks.
- E. Septic systems or drain fields:
  - 1. Bioretention and permeable pavement are not permitted within 10 feet of a proposed or existing small on-site sewage disposal drainfield, including reserve area, and grey water reuse systems.
  - 2. Bioretention and permeable pavement shall be set back from a proposed or existing large on-site sewage disposal system in accordance with Chapter 246-272B Washington Administrative Code.
  - 3. Other infiltration facilities are not permitted within 100 feet of proposed or existing septic systems or drain fields.
- F. Contaminated soil or groundwater

Infiltration has the potential to mobilize contaminants present in soil and groundwater. Unless a different setback is given in an approved cleanup plan, the following setbacks apply to areas with known soil or groundwater contamination (typically federal Superfund sites or state cleanup sites under the Model Toxics Control Act (MTCA):

- 1. Areas known to have deep soil contamination:
  - a Bioretention, permeable pavement, and other infiltration facilities serving less than 5,000 SF of impervious surface are not permitted within 100 feet of an area known to have deep soil contamination.
  - b Other infiltration facilities serving 5,000 SF or more of impervious surface are not permitted within 500 feet of an area known to have deep soil contamination.
- 2. Where groundwater modeling indicates infiltration will likely increase or change the direction of the migration of pollutants in the groundwater.
- 3. Within 10 feet (horizontal) of contaminated surface soils.

#### 4. Landfills:

- a. Bioretention, permeable pavement, and other infiltration facilities serving less than 5,000 SF of impervious surface are not permitted within 100 feet of a closed or active landfill.
- b. Other infiltration facilities serving 5,000 SF or more of impervious surface are not permitted within 500 feet of a closed or active landfill unless a licensed hydrogeologist determines that stormwater can be safely infiltrated.

### 21.4. Vertical Setbacks

Infiltration facilities require a minimum vertical separation from the bottom of the facility to the underlying water table, bedrock, or other impermeable layer. Separation requirements depend upon the facility type and the facility's tributary area. Vertical setbacks for each facility type are given in the Stormwater Manual.

### 21.5. Verification Testing

The City may require verification testing for infiltration facilities where the City determines there may be a risk of infiltration system failure. Site conditions that justify infiltration facility verification testing include: low infiltration capacity soils, history of infiltration failure in the project area, high groundwater levels, risk of flooding in the event of system failure, indications of sediment loads to the facility during construction, indications of soil compaction during construction, new information gained during construction with regards to infiltration facility design, and performance information such as better soils data, or groundwater data.

Page intentionally left blank.

## Chapter 22. Surface Water Project Classifications

The City classifies stormwater impacts into four project classifications based on the Minimum Requirements. Applicability of the Minimum Requirements shall be determined using the thresholds given in the Stormwater Manual Vol. I: 2.4 and the definitions given in the Stormwater Manual Appendix I-G.

### 22.1. Small Impact Projects.

These projects trigger Minimum Requirement #2: Construction Stormwater Pollution Prevention, as described in the Stormwater Manual. Applicants are required to submit a Construction Stormwater Pollution Prevention Plan (SWPPP) consisting of:

- A. Drainage Summary Form – Small Impact
- B. SWPPP – Modified Small Project SWPPP

### 22.2. Medium Impact Projects.

These projects trigger Minimum Requirements #1 through #5 of the Stormwater Manual. There are two sub-classifications of Medium Impact Project: single-family/duplex and single-family/duplex/commercial.

#### A. Medium Impact Project – single-family/duplex

1. The City has prepared a Medium Impact Project pamphlet to help with preparation of surface water plans for single-family residential projects that meet the following criteria. The BMPs are chosen from a specific list and are “presized” to eliminate the need for calculations. The designed infiltration rate is assumed as 0.3 inches per hour. A site development plan prepared by a licensed professional is optional for this classification.

- a. Project is one single-family residence or one duplex;
- b. The site is smaller than 22,000 SF;
- c. There are no critical areas within or abutting the site;
- d. The project adds or replaces less than 5,000 SF of hard surface.

#### B. Medium Impact Project – single-family/duplex/commercial



1. This classification includes multi-family residential development, and other development within 100 feet of critical areas such as floodplains, streams, wetlands, shorelines, or geologically hazardous areas. The project adds or replaces less than 5,000 SF of hard surface.
  - a. A licensed engineer must prepare the site development plan.
- C. A medium impact project submittal consists of:
  1. SWPPP
    - a. SWPPP
    - b. SWPPP Construction Schedule
    - c. SWPPP Standard Plans (typical details)
    - d. SWPPP Standard Plan Notes
  2. Surface Water Summary Form – Medium Impact
  3. Soils Report prepared by a professional soil scientist certified by the Soil Science Society of America (or equivalent national program), a licensed on-site sewage designer, or by other suitably trained person working under the supervision of a professional engineer, geologist, hydrogeologist, or engineering geologist registered in the State of Washington.
  4. Civil Site Development Plan
  5. Civil Site Development Standard Plans (typical details)
  6. Civil Site Development Standard Plan Notes
  7. Easement for drainage and stormwater facilities and recorded O&M Manual.

### 22.3. Large Impact Projects.

Large Impact Projects trigger Minimum Requirements #1 - #9 of the Stormwater Manual.

- A. The project engineer should complete the site assessment and preliminary layout and then schedule a meeting with the City to review and provide feedback on additional analysis that may be required to meet the City's stormwater regulations, including low impact requirements for site design.
- B. A large impact plan submittal consists of:

1. Survey
2. Site Assessment Summary
3. Geotechnical Report. Soils analysis not accepted for estimating infiltration rates; PIT required
4. Surface Water Report (see Appendix C)
5. SWPPP
  - a. SWPPP
  - b. SWPPP Construction Schedule
  - c. SWPPP Standard Plans (typical details)
  - d. SWPPP Standard Plan Notes
  - e. Civil Site Development Plan
6. Site Development Plan
  - a. Site Development Standard Plans (typical details)
  - b. Site Development Standard Plan Notes
7. Before final approval: easement for drainage and stormwater facilities, and recorded covenant for O&M Manual/Pollution Prevention Plan

Page intentionally left blank.

## Chapter 23. Site Development Plan

Refer to Stormwater Manual: Vol. I: Chapter 3 and BMP T5.21 Better Site Design.

Site planning and layout are critical in reducing the amount of stormwater runoff generated by a project site. Project layout must address site planning and layout, must consider the opportunities to reduce or minimize impervious surface, and must utilize LID techniques for managing stormwater.

The following criteria shall be addressed in project layout and site design:

- A. Locate development areas outside of conserved vegetation/habitat/wildlife areas and within designated buildable areas to minimize soil and vegetation disturbance and take advantage of a site's natural ability to store and infiltrate stormwater.
- B. Limit effective impervious areas to less than 10 percent for both residential and commercial developments.
- C. Orient residential lots to minimize site disturbance, maximize the benefits of minimal excavation foundation systems; facilitate sheet flow into natural resource protection areas and bioretention facilities; and promote community aesthetics, livability, and privacy.
- D. Eliminate stream crossings with roads and conveyance systems whenever possible.
- E. Minimize impervious surfaces by reducing building footprints, road length and width, parking areas, and driveways. Utilize shared parking, multi-storied parking, or parking facilities located under the structure. Any outdoor parking areas shall be designed with bioretention facilities that are interspersed throughout the parking lot area to receive stormwater runoff from the impervious surfaces.
- F. Use dispersion or infiltration best management practices to diminish or eliminate effective impervious areas by directing stormwater from impervious areas.
- G. Integrate small, dispersed bioretention areas to capture, store, and infiltrate stormwater on site.

- H. Lay out roads, lots, and other proposed site features to follow topographic contours to minimize soil and vegetation disturbance and loss of topsoil or organic duff layer.
- I. Utilize pervious paving surfaces such as porous pavement or pavers for roads, driveways, parking lots, or other driving or walking surfaces.
- J. Direct rooftop runoff to infiltration areas, full dispersion systems, or to cisterns for non-potable reuse, or utilize vegetated roof systems to evaporate and transpire stormwater.
- K. Minimize Clearing and Grading. Grading should be kept to a minimum by incorporating natural topographic depressions into the development and limiting the amount of cut-and-fill on those portions of the site with permeable soils. At a minimum, the following standards shall be utilized:
  - 1. Any portion of the site with permeable soils should be closely considered for preservation to promote infiltration of stormwater runoff;
  - 2. Areas of rich topsoil should either be left in place or, if excavated in construction areas, utilized elsewhere on the site to amend areas with sparse or nutrient deficient topsoil;
  - 3. Direct runoff to areas of permeable soils or natural depression areas to promote infiltration;
  - 4. Distances for overland flow must be kept short to promote sheet flow and minimize concentration of runoff;
  - 5. Grading shall not increase steep, continuous slopes;
  - 6. Limit clearing to road, utility, building pad, lawn areas, and the minimum amount of extra land necessary to maneuver machinery (e.g., a 10-foot perimeter around a building). All other land outside these areas shall be protected with construction fencing to prevent intrusion and compaction by construction equipment or other types of vehicles.
- L. Protect Vegetation During Construction. The following steps must be taken to protect vegetation during construction:
  - 1. Map natural resource protection areas on all plans and delineate these areas on the site with silt, construction, or other appropriate fencing to protect soils and vegetation from construction damage.

2. Before any groundwork begins, meet and walk property with equipment operators to clarify construction boundaries and limits of disturbance.
3. Protect drainage areas during construction. If an area has any type of channel/drainage swale that provides a hydrologic connection to vegetation protection area(s), then the channel must also be protected throughout the construction phase by fencing and use of erosion control measures to prevent untreated runoff from the construction site flowing into the channel.
4. Install signs and fences to identify and protect natural resource protection areas.
5. Protect trees and tree root systems utilizing the following methods:
  - a Reduce soil compaction during the construction phase by protecting critical tree root zones that usually extend beyond the tree's canopy or drip line;
  - b Prohibit the stockpiling or disposal of excavated or construction materials in the vegetation retention areas to prevent contaminants from damaging vegetation and soils;
  - c Avoid excavation or changing the grade near trees that have been designated for protection. If the grade level around a tree is to be raised, a dry rock wall or rock well shall be constructed around the tree. The diameter of this wall or well should be at least equal to the diameter of the tree canopy plus five feet;
  - d Restrict trenching in critical tree root zone areas or require use of air spade excavation and/or root pruning;
  - e Prevent wounds to tree trunks and limbs during the construction phase;
  - f Prohibit the installation of any impervious surfaces in critical root zone areas. Where road or sidewalk surfaces are needed under a tree canopy, unmortared porous pavers or flagstone (rather than concrete or asphalt) or bridging techniques should be used;
  - g Prepare tree conservation areas to better withstand the stresses of the construction phase by fertilizing, pruning, and mulching around them well in advance of construction activities.

Page intentionally left blank.

## Chapter 24. Stormwater Pollution Prevention Plan (SWPPP)

### 24.1. SWPPP Requirements

Refer to the Stormwater Manual Vol. I: 2.5.2, Minimum Requirement #2, Construction Stormwater Pollution Prevention (SWPP).

A. All development, regardless of size, must comply with Minimum Requirement #2 Construction Stormwater Pollution Prevention (SWPP), even when a permit is not required. The following are minimum requirements need to be shown on the plan for all projects:

- 1 Site areas which do not need to be disturbed shall remain undisturbed (clearing limits are defined and maintained);
- 2 Runoff from areas not under construction does not flow over disturbed soils;
- 3 Temporary cover on disturbed soils that are not being worked;
- 4 Permanent cover installed without unnecessary delay on all areas at final grade;
- 5 Off-site streets are kept free of dirt and mud originating from the construction site, using sweeping, not flushing, in the streets and, if appropriate, on-site wheel wash facilities;
- 6 Dust is controlled and is in compliance with the Puget Sound Clean Air Agency; and
- 7 Work in Critical Areas conforms to requirements of the City's Critical Areas Ordinance (CAO).
- 8 Plans need to show construction BMP's to be used during construction.

B. If the project proposes to add or replace at least 2,000 SF of impervious surface or if it proposes to grade or clear at least 7,000 SF of land, then the SWPPP will include a narrative as well as drawings and standard plans.

C. If construction is being phased, the Director may require separate SWPPP plans to address the specific needs for each phase of construction.

D. During construction, the SWPPP shall be revised as necessary by the Certified Erosion and Sediment Control Lead (CESCL) or SWPPP supervisor to address changing site conditions, unexpected storm events, or non-compliance with the SWPPP performance criteria.



- E. The City may stop site work if the SWPPP is not being monitored and maintained, or if the runoff leaving the site exceeds state standards.

## 24.2. Rainy Season

- A. The rainy season is defined as the months between October 1 and April 30 of any given year.
- B. Slope stability and adequate protection of receiving waters are major concerns during the rainy season. For the following activities, clearing and grading is prohibited during the rainy season, unless the City has specifically given approval to continue or to initiate clearing and grading:
  - 1 Clearing and grading of 11,000 SF or more; or
  - 2 Disturbing more than 7,000 SF of soil and:
    - a Having area(s) that drain, by pipe, open ditch, sheet flow, or a combination of these to a tributary water, and the tributary water is one-quarter mile or less downstream; or
    - b Having slopes steeper than 15 percent adjacent or on-site; or
    - c Having highly erodible soils adjacent or on-site; or
    - d Located upstream of a critical area or critical area buffer; or
    - e Having high groundwater table or springs.
  - 3 Exemptions:
    - a Routine maintenance and necessary repair of erosion and sediment control BMPs;
    - b Routine maintenance of public facilities or existing utility structures that do not expose the soil or result in the removal of the vegetative cover to soil; and
    - c Activities where there is one hundred percent infiltration of surface water runoff within the site in approved and installed erosion and sediment control facilities.

### C. Seasonal Suspension Plan

1. When rainy season construction is prohibited, the Applicant shall provide a Seasonal Suspension Plan for review and approval. The plan shall be submitted to the City no later than September 1 and must be implemented and inspected by September 30.
2. The seasonal suspension plan shall include the following:
  - a. CESCL (with contact information) having the authority to direct implementation of additional measures or maintenance and repair of existing measures;
  - b. Inspections increased to weekly;
  - c. Erosion prevention and sediment control plan that protects all disturbed areas:
    1. Areas that are to be unworked during the wet season shall be seeded and mulched by September 30;
    2. Cover measures shall be installed on all areas where seeding is not well established;
    3. All soil stockpiles and steep cut-and-fill slopes shall have cover measures;
    4. Construction road and parking lots shall be stabilized.
3. Stockpile on-site cover materials sufficient to cover 50 percent of disturbed areas.
4. Stockpile on-site at least 50 linear feet of silt fence (and the necessary stakes) per acre of disturbance.
5. Additional requirements for projects one acre or greater:
  - a. Designated CESCL with contact information;
  - b. Contingency plans for controlling spills and other potential pollutants which have been developed and are ready to implement at the construction site;
  - c. Designated point of contact that can call out and direct crews 24 hours a day and seven days a week (24/7), obtain materials, and authorize immediate expenditures for on-site temporary erosion prevention and sediment control work;

- d Compliance with all project approval conditions and permits (including Hydraulics Project Approval from Washington State Department of Fish and Wildlife and the Washington Department of Ecology NPDES Construction Stormwater General Permit);
- e Ensure that turbidity in runoff from the construction area does not exceed 25 NTU or 5 NTU above background.

C. When clearing and grading during the rainy season is prohibited, building construction can proceed as long as clearing and grading is halted and the seasonal suspension plan is in place and being maintained.

### 24.3. Stop Work

If a clearing and grading/site development permit is issued, and the City subsequently issues three stop-work orders for insufficient erosion prevention and sedimentation control, the permit will be suspended until the dry season, or, if violations occurred in the dry season, until weather conditions are favorable and effective erosion and sedimentation control is in place. The suspension will be removed at the end of the rainy season or upon the City's determination that appropriate BMP's have been installed and are working and that the Permittee has adequate resources and abilities to manage BMPs effectively without further discharges that do not meet requirements.

## Chapter 25. Flood Control

The City of Shoreline has identified areas in Thornton Creek Basin and along the Puget Sound coastline as flood plain areas. Projects in these areas must be checked for applicability of FEMA flood plain development requirements. When subject to such requirements, a project must meet the standards in SMC Chapter 13.12.

Page intentionally left blank.

## Chapter 26. Conveyance System

### 26.1. Pipe Specifications

A. Acceptable pipe materials are given in Table 20, Pipe Materials, Cover and Bedding.

**Table 20.** Pipe Materials, Cover and Bedding

Pipe Material	Minimum Cover (in)	Pipe Bedding Requirements
Perforated Corrugated polyethylene pipe (CPEP) (smooth interior)	24	3/4" minus crushed rock, compacted in 8-inch lifts
Non-perforated CPEP (smooth interior)	24	5/8" minus crushed rock, compacted in 8-inch lifts.
Reinforced concrete (RCP) or Polyvinylchloride (PVC – ASTM 3034)	12	Same as non-perforated CPEP
Ductile iron pipe	6	Same as non-perforated CPEP
Yard drain lines – any material	18	5/8" minus crushed rock, compacted in 8-inch lifts.

B. Conveyance system specifications are given in Table 21, Conveyance System Specifications. The Applicant/Permittee is responsible for determining proper pipe size. The Director may require the owner to verify the adequacy of the pipe size and to expand the conveyance system, such as adding pipe or catch basins.

**Table 21.** Conveyance System Specifications

Element	Amendment
Acceptable Pipe Sizes	<ol style="list-style-type: none"> <li>1. For public stormwater pipe and storm pipe in the right-of-way, the minimum diameter shall be 12 inches. With Director approval, eight-inch diameter pipe may be permitted on cross street laterals less than 66 feet long to avoid utility conflict or meet shallow gradient.</li> <li>2. For private stormwater pipe, the minimum size shall be six inches.</li> </ol>

Element	Amendment
Pipe Connections [King County Road Standards (KCRS 2007)]	SWPE: 1. Solid wall polyethylene (SWPE) pipe with maximum SDR of 32.5, minimum cell Class ASTM D3350-06 and meeting WSDOT Specifications for ductile iron pipe with restrained mechanical joints may be used for outfalls on steep slopes. Above ground installation of SWPE does not require pipe bedding. 2. Thermoplastic pipe, (e.g., SWPE) shall be tested using the deflection test procedure described in Section 7-17.3 of the WSDOT Standard Specifications.
Changes In Pipe Size (KCRS 2007)  Pipe System Connections [KCRS 7.04 C (2007)]	Connections to pipe systems may be made without placing a catch basin or manhole on the mainline by meeting all of the following conditions: 1. The mainline pipe diameter is 48 inches or greater and at least two times the size of the connecting pipe; 2. Make connections in accordance with the manufacturer's recommendations. Standard shop fabricated tees, wyes and saddles shall be used, except for concrete pipe connections; 3. There shall be a catch basin or manhole on the connecting pipe within two to 10 feet of the external wall of the main line; 4. Offset angle of connecting pipe to mainline, horizontally and vertically, shall be less than 45 degrees; 5. Two-point survey control shall be used to set catch basin locations.
Pipe Design between Structures (KCRS 2007)	In the right-of-way: 1. Catch basins shall be spaced no greater than 150 feet for grades less than one percent, 200 feet for grades between one percent and three percent and 300 feet for grades three percent and greater. 2. Catch basins rather than inlets shall be used to collect stormwater from road surfaces, unless approved by the Surface Water and Environmental Services (SWES) Manager.

Element	Amendment
Pipe System Installation	<ol style="list-style-type: none"> <li>1. Install pipe in accordance with section 7-08 of the WSDOT Standard Specifications.</li> <li>2. For nonmetallic pipe that does not contain wire or other acceptable proximity detection features, add detection wire or place in a cast iron or other acceptable metal casing.</li> <li>3. Unstable soil conditions, such as peat, shall be removed from under pipes unless special measures are approved by the City.</li> <li>4. For pipe crossings In the right-of-way:               <ol style="list-style-type: none"> <li>a. A pad is required for some installations to provide additional protection between adjacent utilities. The size of the pad shall be based on the outside diameter (O.D.) of the larger crossing pipe. The pad shall be O.D. by O.D. square by two and one-half inches thick minimum or as required to protect the pipes. The pad shall be a strong, resilient, medium-density, closed-cell, polyethylene foam plank (Dow Ethafoam 220, or accepted equivalent).</li> <li>b. A pipe sleeve is required for some installations to provide additional protection of stormwater from potential leakage from other utilities. A pipe sleeve shall be a single section of PVC pipe (no joints) with a minimum length of three feet to each side of pipe crossing. The pipe sleeve shall be placed around the stormwater pipe with the annular space between the pipe sleeve and the stormwater pipe filled with grout.</li> </ol> </li> </ol> <p>Additional measures may be necessary to ensure system integrity and may be required on a case-by-case basis.</p>
Pipe Testing (KCRS 2007)	<ol style="list-style-type: none"> <li>1. Thermoplastic pipe (e.g., SWPE) shall be tested using the deflection test procedure described in Section 7-17.3 of the WSDOT Standard Specifications.</li> </ol>



C. Conveyance vertical clearances are given in Table 22, Conveyance System Vertical Clearances.

**Table 22.** Conveyance System Vertical Clearances

Utility	Location (Above or below Storm Pipe)	Minimum Clearance	Special Requirement
Electrical	Above or below	12 inches	Standard
Communications	Above or below	12 inches	Standard
Water main or gas main	Above or below	12 inches	Standard
Water main or gas main	Above or below	6 inches	Ethafoam pad
Sanitary Sewer	Below storm pipe	12 inches	Standard
Sanitary Sewer	Above storm pipe	18 inches	Standard
Sanitary Sewer	Above or below storm pipe	6 inches	Pipe sleeve and Ethafoam pad
Liquid petroleum	Above or below	18 inches	
Pipe Clearances (KCRS 2007)	<p>In the Right-of-way:</p> <p>1. Horizontal Clearance and Crossing Angle The minimum horizontal spacing between closed storm drains and water mains, gas mains, other underground utility facilities and all structures shall be five feet horizontally. The minimum horizontal distance between any open storm drainage facilities (swales, open channels, biofiltration swales, etc.) and water mains, gas mains, and other underground facilities shall be 10 feet. For pipe crossings, the preferred angle is 90 degrees, but 20 degrees obtuse or acute of 90 degrees is acceptable.</p> <p>2. Vertical Clearance – Utilities The minimum vertical clearance spacing between the outside of storm drain pipelines and water mains, gas mains, electrical or communication conduits, and other underground utility facilities, shall be as noted above. It is expected that the “Standard” vertical clearance will be provided. If that is not possible, use of pads or pipe sleeves may be allowed with approval from the Surface Water and Environmental Services (SWES) Manager.</p>		

## 26.2. Drop Structures

Drop structures shall only be allowed through an Engineering Deviation (see Division 2 Section 6.3) and in General, drop structures will not be approved if the drop is less than five feet.

## 26.3. Rockeries/Retaining Walls Crossing

Crossing of rockery/retaining wall and drain pipe should be perpendicular. Depending on conditions, the drain pipe may need a steel casing per engineer recommendation.

Rockerries and retaining walls may have foundation drains, when required by the design engineer. The foundation drain outlets must connect to an approved outfall.

## 26.4. Ditch Modifications

Ditches are an integral part of the Stormwater conveyance system within the right of way and as such, modifications shall be reviewed and approved through the permit process.

- A. Ditches having 10 percent or flatter longitudinal slopes shall remain open. The City may approve enhancement when either a “natural drainage system” swale design or a “bioretention ditch” design is proposed.
- B. Ditch closure approvals are subject to the following criteria, in accordance with City of Shoreline Administrative order #EDG 000109-072209:
  - 1 A right-of-way use permit is required. The design must be prepared by a Washington State licensed professional engineer. The City will review all applications to verify compliance with the City’s critical areas requirements.
  - 2 The property owner is responsible of the cost of permit, engineering, materials, labor, and equipment required for the installation.
  - 3 The preferred pipe material is perforated corrugated polyethylene pipe (smooth interior). Types of pipe other than those listed in the Table 22 may be approved based on site constraints. Perforated pipe is not recommended when the bottom elevation of the ditch line is below the finished floor elevation of nearby structures.

- 4 Minimum pipe diameter (interior) is 12 inches. Larger pipes may be required by existing conditions or proposed changes.
- 5 Join dissimilar materials directly underground using a coupler specifically designed for the two types of material used. If the coupler does not exist for the two particular materials, then a structure is required to make the material transition.
- 6 Install a catch basin: 1) at low points that drain to the ditch, 2) at locations where roof downspouts, footing drains or other surface water piping connects to the ditch, and 3) for maintenance purposes, when the pipe run is 100 feet or greater.
- 7 Once the pipe is installed and covered, the disturbed areas must be graded such that any runoff from the road and private property is directed to a catch basin or open ditch. Cover the graded area using compacted 5/8" minus crushed rock.
- 8 Reasonable use of the adjacent property is not possible. This includes culvert installations that are necessary to provide driveway access.
- 9 Harm or threat of harm to public health, safety and welfare, the environment, or public and private property must not exist or be a result of the work.

C. Modifications must be designed by a professional engineer and must meet the material and design requirements of this chapter.

# DIVISION 4 – CONSTRUCTION AND INSPECTION

Page intentionally left blank.

## Chapter 27. Construction

### 27.1. Standards

Construction, workmanship and materials shall be in accordance with the approved plans, permit conditions, and the standards referenced in this manual. Any change to these standards, during construction in the right-of-way, must be approved by the Director.

- A. Standard Specifications for Road, Bridge, and Municipal Construction M 41-10, WSDOT.
- B. Surface Water Design Manual, Chapter 4 “Conveyance System Analysis and Design”, King County, as amended in Division 3 Surface Water.
- C. Manual on Uniform Traffic Control Devices, Federal Highway Administration:  
<http://mutcd.fhwa.dot.gov/>

### 27.2. General

#### A. Work Hour Restrictions

Work in arterials is restricted to the hours between 9:00 a.m. and 3:00 p.m.

Sounds originating from construction sites, including but not limited to sounds from construction equipment, power tools and hammering between the hours of 10:00 p.m. and 7:00 a.m. on weekdays and 10:00 p.m. and 9:00 a.m. on weekends are considered public disturbance (SMC 9.05.010), except construction noise or other noise generated in response to emergency situations, in times when unexpected and uncontrollable events result in an imminent risk of physical harm or property damage.

Weekend or City-recognized holiday work may be allowed with five working days prior approval.

#### B. Survey Monuments

Anyone performing construction, maintenance, or other work in Shoreline must protect all survey monuments within the area of work.

The Permittee is responsible for all contractors working for him/her. If it is necessary to disturb a survey monument, the Inspector must be notified and a permit from the Department of Natural Resources must be obtained before the disturbance occurs.

Failure to comply with Washington State requirements RCW 58.04.015 regarding monument removal or destruction is a gross misdemeanor and is punishable by a fine and/or imprisonment, and liability for the cost of reestablishment.

### C. Vegetation

Drainage areas must be protected during construction. If an area has any type of channel/drainage swale that provides a hydrologic connection to vegetation protection area(s), the channel must also be protected throughout the construction phase by fencing and use of erosion control measures to prevent untreated runoff from the construction site to flow into the channel.

Trees and tree root systems must be protected utilizing the following methods:

Reducing soil compaction during the construction phase by protecting critical tree root zones;

Prohibiting the stockpiling or disposal of excavated or construction materials in the vegetation retention areas to prevent contaminants from damaging vegetation and soils;

Avoiding excavation or changing the grade near trees that have been designated for protection. If the grade level around a tree is to be raised, a dry rock wall or rock well shall be constructed around the tree. The diameter of this wall or well should be at least equal to the diameter of the tree canopy plus five feet;

Restricting trenching and excavation in critical tree root zone areas; (See Figure 4 Tree Protection During Construction)

Preventing wounds to tree trunks and limbs during the construction phase. In the event that a tree is damaged during construction, a licensed arborist shall inspect and determine if replacement is needed.

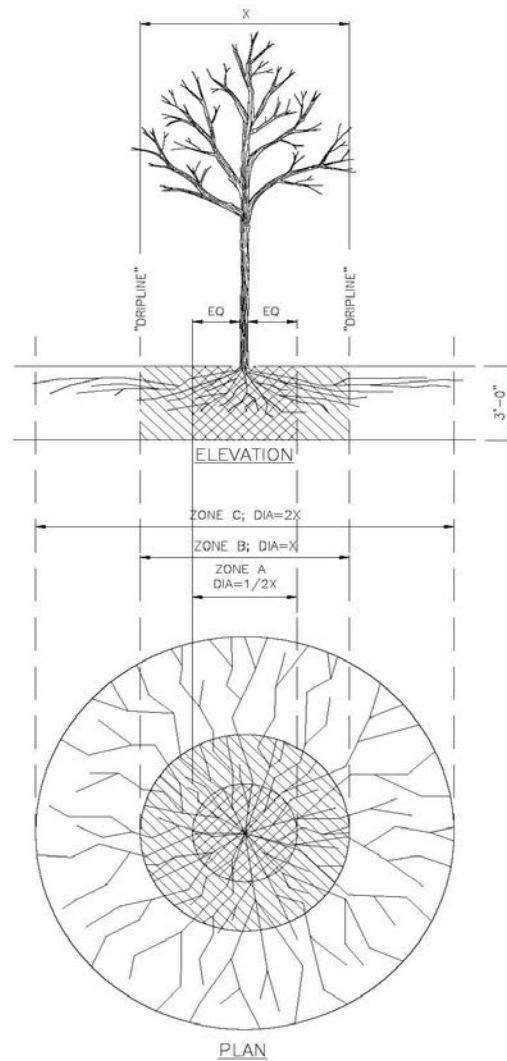

A TREE, VEGETATION, AND SOIL PROTECTION PLAN (TVSPP) IS REQUIRED FOR ALL PROJECTS. APPROVAL OF PLAN REQUIRED PRIOR TO MOBILIZATION. SEE SECTION 8-01.

**TRENCHING/EXCAVATION**

**ZONE A (CRITICAL ROOT ZONE)**

1. NO DISTURBANCE ALLOWED WITHOUT SITE-SPECIFIC INSPECTION AND APPROVAL OF METHODS TO MINIMIZE ROOT DAMAGE
2. SEVERANCE OF ROOTS LARGER THAN 2" DIA REQUIRES ENGINEER'S APPROVAL
3. TUNNELING REQUIRED TO INSTALL LINES 3'-0" BELOW GRADE OR DEEPER

**ZONE B (DRIPLINE)**

1. ZONE B FOR ASYMMETRICAL COLUMNAR AND NARROW CONICAL TREE FORMS. ZONE B = 1' RADIUS FOR EVERY 1" OF TRUNK DIAMETER.
2. TUNNELING MAY BE REQUIRED FOR TRENCHES DEEPER THAN 3'-0".

**Figure 4. Tree Protection – Right-of-way**

**D. Permanent Traffic Control**

All channelization and pavement markings such as raised pavement markers, paint, thermoplastics, etc., shall be pre-marked by a City-approved striping contractor, and the layout approved by the Inspector, prior to permanent installation by the contractor.

Approval may require a three working day advance notice for layout approval.

The Permittee shall maintain traffic control devices in condition acceptable to the City until the permit is final. The Permittee must maintain signs in good condition until the



development and right-of-way are accepted by the City. Any damaged signs will be replaced by the property owner at her/his expense.

E. Cleanup, incidental and collateral damage

The street right-of-way, material storage sites, construction staging areas, and all other areas affected by the work shall be left neat and presentable, and shall be fully restored as necessary to pre-existing or better condition.

Costs associated with site cleanup and restorations are integral to the project. If the City incurs additional cleanup costs, these costs may be billed to the Permittee or contractor. Moreover, except as provided in RCW 19.122.030, any damage or destruction to existing public or private facilities done during the course of work shall be restored at the Permittee's or contractor's expense. This includes restoration of all traffic devices and pavement markings. The Director shall determine the extent of damage and order the extent and type of restoration, except as provided in RCW 19.122.030.

### 27.3. Temporary Traffic Control

Per SMC Chapter 12.15, a traffic control plan shall be prepared for any activities within the right-of-way that disrupt traffic patterns.

A temporary traffic control (work zone) plan must be submitted and approved before beginning any work requiring traffic control.

The Inspector may approve field adjustments to traffic control to meet actual conditions.

The traffic control plan shall be consistent with the standards defined in the MUTCD. The following basic principles and standards must be observed by all those who perform work within a street right-of-way.

- A. Work areas are safe and congestion is minimized;
- B. Motorized and non-motorized traffic is warned, controlled, and protected;
- C. Emergency access is maintained; and
- D. All traffic is expedited through the work zone to the extent possible.

The traffic control plan must allow for continued emergency services. For pedestrian and business disruption, the plan shall contain adequate connections and clear signage.

The traffic control plan should show existing right-of-way conditions, such as accesses, channelization, lane widths, all traffic control devices, bicycle/pedestrian paths, bus stops, and pavement edge.

The traffic control plan must allow for continued emergency services, for pedestrian and business disruption, the plan shall contain adequate connections and clear signage.

If steel plates are approved for use, the plates shall be pinned and cold mix asphalt shall be added to provide suitable transition from the roadway to the top of the steel plates.

“MOTORCYCLES USE EXTREME CAUTION” signs and appropriate plaques shall be installed for each traffic directions when conditions stated in RCW 47.36.200 require them.

## 27.4. Staking

At a minimum, items that require staking include property corners, subgrade elevations, slope (grade) stakes, right-of-way location, drainage structures and other permanent structures.

In the right-of-way, all surveying and staking must be performed by an engineering or surveying firm capable of performing such work. The engineer or surveyor directing such work will be licensed by the State of Washington.

A pre-construction meeting will be held with the City prior to commencing staking. The minimum staking of streets will be as follows:

- A. Stake centerline alignment every 25 feet (50 feet in tangent sections) with cuts and/or fills to subgrade;
- B. Stake top of ballast and top of crushed surfacing at centerline and edge of pavement every 25 feet;
- C. Stake top back of curb at a consistent offset for vertical and horizontal alignment;
- D. Staking will be maintained throughout construction.

## 27.5. Trenches

### A. General

1. The Director may require trenchless methods such as boring or jacking, except a) when it is demonstrated that trenching methods are not possible due to surface and subsurface conflicts or soil conditions, or b) when the utility is installed after reconstruction or overlay of the road.
2. Open trench sides shall be kept as nearly vertical as possible and follow WISHA safety requirements.
3. When ground water is anticipated or is encountered during trenching, a dewatering plan must be provided for approval.

### B. Backfill

1. All subgrade will be compacted to 95 percent maximum density as described in Section 2-03 of the latest version of the WSDOT Standard Specifications;
2. Crushed surfacing materials used for backfill will conform to Section 4-04 of the latest version of the WSDOT Standard Specifications;
3. Granular material will conform to Section 9-03.19 of the latest version of WSDOT Standard Specifications;
4. Native material may be used if deemed acceptable by the City. Soils test are required to determine if the material is acceptable and to test for adequate compaction. When existing material is used, the top 6" shall be Crushed Surfacing Top Course;
5. CDF shall meet the requirements of 2-09.3 of the 2012 or latest version of the WSDOT Standard Specifications. CDF shall not be used within 10 feet of a steam line.

### C. Temporary Trench Closure

1. Trenches that will receive traffic or that will be left overnight before final restoration shall be covered by a temporary patch or by installation of steel plates. The temporary patch material can be hot mix, cold mix, or asphalt-treated base (ATB) dumped directly into the trench, bladed out, and compacted. The trench must be filled flush to the surrounding surfaces to provide a smooth riding surface.
2. Use of steel plates requires approval from the Inspector. If approved shall follow section 28.4 of this chapter.
3. Steel plate(s) shall cover CDF for at least 48 hours prior to pavement placement.

4. Prior to predicted or possible snow events, the Inspector must be notified of all the locations of steel plates.

## 27.6. Traffic Signal Loops

Coordination of disruptions to signal loops during construction will occur at the project pre-construction meeting.

No spicing of traffic signal loops shall be permitted within the roadway.

## 27.7. Sidewalks

Temporary sidewalks shall be at least five feet wide, except temporary sidewalks installed during construction in accordance with Chapter 7.5 Frontage Improvements.

### A. Permanent sidewalks

1. During removal, panels should be removed to the nearest complete and competent panel.
2. Installation:
  - a. See Standard Plan 309 Curb and Sidewalk Joints;
  - b. Install an 18-inch root barrier placed between trees and sidewalks/curbs/driveways;
  - c.. Use Class 4000 concrete four-inches thick with a non-slip broom finish, except driveway approaches, where the concrete shall be six-inches thick;
  - d. Surfacing shall be Portland cement concrete. The concrete shall be placed and finished per WSDOT Standard Specifications 8-14.3 (3);
  - e. All concrete shall be free of postmarks, graffiti, footprints, and tire marks prior to acceptance;
  - f. Concrete sidewalks shall be cured for at least 72 hours. During curing time, sidewalk must be protected from pedestrian and vehicle traffic;
  - g. An expansion joint consisting of 3/8" or 1/4" x 2". Full depth of premolded joint material shall be placed around fire hydrants, poles, posts, utility castings, and along walls or structures in paved areas;

- h. A dummy joint consisting of 3/8" or 1/4" x 2" of premolded joint material shall be placed in curbs and sidewalks at a minimum of 15-foot intervals and at sides of drainage inlets. When curbs and/or sidewalks are placed by slip-forming, a premolded strip up to 1/2" thick and up to full depth may be used;
- i. Dummy joints in sidewalks shall be located so as to match the joints in the curb whether the sidewalk is adjacent to curb or separated by an amenity zone;
- j. Tool marks consisting of 1/4" V-grooves shall be made in sidewalk at five-foot intervals or equal to width of sidewalk, intermediate to the dummy joints;
- k. Interface between curb and adjacent sidewalks on integral pour construction shall be formed with 1/4" radius edging tool. On separate pour construction an expansion joint consisting of 3/8" or 1/4" x 2" full depth of premolded joint material shall be placed between the curb or thickened edge and the adjacent sidewalk.

## 27.8. Landscaping

### A. Soil

1. All disturbed soils that do not have structures on them shall be remediated according to BMP T5.13 Post Construction Soil Quality and Depth (Stormwater Manual); except
2. Soils for improvements, such as biofiltration and raingardens, shall meet specified material and installation requirements.

### B. Trees

#### 1. Installation:

- a. All landscaping shall be installed according to sound horticultural practices in a manner designed to encourage quick establishment and healthy plant growth;
- b. Location of plants shall be based on the plant's mature canopy and root mat width. For planting purposes, root mat width is assumed to be the same width as the canopy unless otherwise documented in a credible print source;
- c. The standard five-foot clearance from underground utilities often is not enough space to minimize the effects of utility maintenance and repair and ensure

longevity of the tree. When right-of-way width allows, additional clearance distance must be provided;

d. When right-of-way width is limited and the five-foot clearance cannot be met, the City will evaluate site conditions and may permit one or both of the following:

2. Tree installation less than five feet clearance from ductile iron or PVC pipe;
3. Tree installation less than five feet from concrete pipe that has rubber gaskets.
  - a. Adjust placement to avoid conflict with driveways, utilities, and other functional needs. Trees should be placed:
    4. Three and one half ( 3 ½) feet back from the face of the curb;
    5. Eight (8) feet from underground utility lines (three feet with root barriers);
    6. Ten (10) feet from power poles (15 feet recommended);
    7. Seven and one-half (7 ½) feet from driveway edges (10 feet recommended);
    8. Twenty (20) feet from street lights or existing trees;
    9. Thirty (30) feet from curb or travel lane street intersections (when no curb).
    10. Ten (10) feet from roadway edge where no curb is present
      - a. Mature tree and shrub root mats may overlap utility trenches, as long as approximately 80 percent of the root mat area is unaffected;
      - b. Trees must be staked using five-foot staking and root barriers between the tree and the sidewalk and curb.

## 27.9. Grading

Amenity zone: the final grade of soil surfaces in planting strips must accommodate runoff from sidewalk surfaces cross-sloped to drain toward the street.

Tree pits shall be graded to provide a soil surface two inches below the adjacent sidewalk and curb elevation, and shall then be top-dressed with bark or wood chips to surrounding grade.

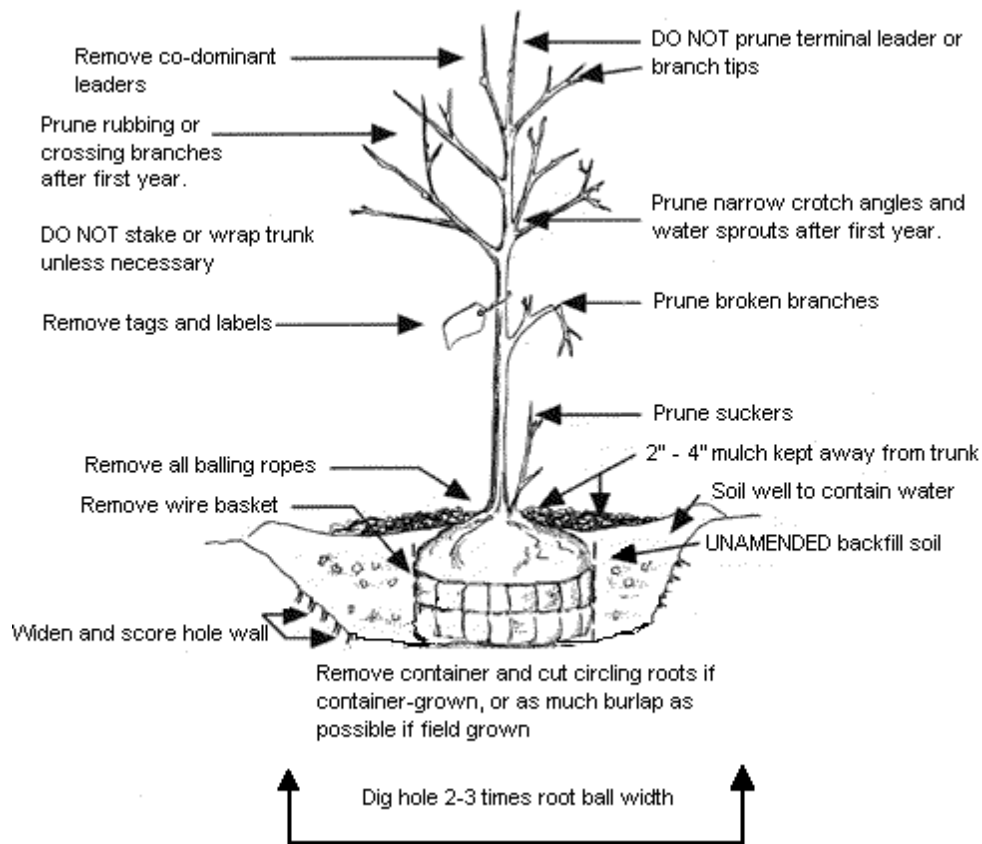

**Figure 5. Tree Installation – Right-of-way**

## 27.10. Curb, Gutter, Access Approach

Type A vertical curb and gutter shall be used on all street classifications. Refer to Standard Plan 312 Curbs. Twenty-four inch wide vertical curb and gutter shall be used only for uniformity or replacement.

All curb and gutter shall be constructed with Class 4000 concrete furnished and placed in accordance with WSDOT Standard Specifications, Sections 6-02, 8-04, and 8-14. Cold weather precautions as set forth in WSDOT Standard Specifications Sections 5-05.3(14) and 6-02.3(6) shall apply.

Subgrade compaction for curbs, gutters, and sidewalks shall meet a minimum 95 percent of maximum density ASTM D1557.

Extruded curb is not allowed in the public right-of-way, unless it is temporary and approved by the Director.

- A. When used, extruded cement concrete curb shall be anchored to existing pavement by either steel tie bars or adhesive in conformance with WSDOT Standard Specification Section 8-04.
- B. When used, extruded asphalt curb shall be anchored by means of a tack coat of asphalt in accordance with WSDOT Standard Specification Section 8-04.

A concrete access approach must have a construction joint at the right-of-way line.

## 27.11. Pavement Restoration

### A. General

- 1. Anyone creating an opening in the right-of-way is responsible for permanent pavement restoration.
- 2. Pavement restoration must be completed within 30 days of trench closure.
- 3. Temporary cold mix patches must be removed and replaced within 30 days.

### B. Concrete Pavement

- 1. Concrete roadway shall be restored to the nearest half panel.
- 2. Concrete shall be replaced or patched with concrete.
- 3. Any concrete pavement traffic lane affected by the trenching shall have all affected panels replaced.
- 4. Concrete pavement shall be connected to existing concrete pavement with dowels and epoxy and restored with WSDOT mix 9-01.2(1).
- 5. Concrete pavement shall be restored consistent with WSDOT Standard Plan A-60.10-0.

### C. Asphalt Pavement

- 1. Refer to Standard Plan 802 Flexible Pavement Patching.
- 2. Asphalt pavement removal may be by full depth saw cut or drum grinder.
- 3. Asphalt pavement cut widths, based on the final trench width, for pavement restoration/patching shall be according to Table 22, Pavement Cut Dimensions; however, the Inspector may extend cut limits to competent roadway pavement.



4. The Inspector shall approve the restoration limits before restoration begins.

**Table 23. Pavement Cut Dimensions**

Trench Depth (FT)	Minimum Cut Beyond Trench (FT) All four sides
Up to 4	1.0
More than 4 up to 6	1.5
More than 6 up to 8	2.0
10	2.5
12	3.0
14	3.5
16	4.0
18	4.5
20	5.0
Pavements less than 5 years old	10.0

*Resource: Utility Cuts in Paved Roads, FHWA-SA-97-049*

5. Cuts in asphalt must be wide enough to accommodate compaction equipment.
6. Cuts shall be expanded to include joints, panel edges, existing patches or cracks within four feet of the opening.
7. Cuts shall be expanded to ensure that new longitudinal joints are not located in a wheel path.
8. The cut face shall be neat, straight and vertical. The corners shall be square.
9. When an existing asphalt paved street is to be widened, the edge of pavement shall be saw-cut to provide a clean, vertical edge for joining to the new asphalt at the time of the placement of the new asphalt. After placement of the new asphalt section, the joint shall be sealed.

#### D. Overlay

1. A public street shall be overlaid when any one of the following conditions applies:
  - a. Utility installation parallel to the pavement centerline requires half street overlay from the centerline to the curb line for the entire length of the utility extension.

- b. If the utility trenching encroaches on both sides of the centerline, a full street overlay will be required;
    - c. Utility installation consisting of three or more perpendicular (transverse) trenches within 150 feet, measured along the pavement centerline, requires overlay from the curb line to the centerline for the full length. If a trench extends beyond the centerline, the Director may require a full street overlay;
    - d. Utility installed at an angle to the pavement centerline requires an overlay from the centerline to the curb line for the entire length of the utility installation. If the utility trenching encroaches on both sides of the centerline, the Director may require a full street overlay;
    - e. When the permit conditions require street improvements and the existing pavement has alligator cracking, the existing pavement must be overlaid from the centerline to the new curb line.
  2. Cold-plane both ends of the overlay perpendicular to the roadway for at least 15 feet to provide a flush transition. For half-street or full-street overlays, cold-planing (grinding) of the entire paving area is required (centerline to gutter or gutter to gutter). When curb and gutter does not exist, the new overlay surface may, at the Director's discretion, be tapered to meet the elevation of adjacent paved surfaces. All asphalt joints and tapered transitions shall be sealed with AR4000 or equivalent.
- E. Testing: prior to placing any asphalt surface materials on the roadway, the Inspector shall review and approve density test reports, certified by a professional engineer, for the crushed surface base course and the crushed surface top course.
  1. Testing shall be performed by a certified independent testing laboratory. The cost of testing is the responsibility of the franchise utility or contractor. The testing is not intended to relieve the contractor from any liability for the trench restoration.
  2. Material testing may be required for trench backfill (native or imported), asphalt, and concrete.
  3. All densities shall be determined by testing specified in WSDOT Standard Specifications.
  4. Compaction of all lifts of asphalt shall be at an average of 91 percent of maximum density as determined by WSDOT Standard Specifications.
  5. Testing of CDF shall be in accordance with WSDOT Standard Specifications.

6. The compaction tests shall be performed in maximum increments of two feet. The number of tests required per square foot of material shall be as follows or as directed by the Inspector:
- a. One test for less than 50 square feet;
  - b. Two tests for 50 to 100 square feet;
  - c. Three tests for 100-plus to 300 square feet;
  - d. One test for every 200 square feet over 300 square feet or every 100 lineal feet of crushed rock.

Page intentionally left blank.

## Chapter 28. Inspection

The City's inspectors inspect work performed under an approved permit. The building inspectors in Planning and Community Development provide inspection services for the permitted on-site work; Public Works right-of-way inspectors provide inspection services for permitted right-of-way development and for franchise permits for the right-of-way.

Inspections for the City's capital improvement projects (CIP) are governed by the CIP contract and are not addressed in this manual.

### 28.1. Authority and Duties of Inspectors

- A. The Inspector functions as a resource for Permittees and contractors. The Inspector:
  - 1. Conducts field investigations;
  - 2. Interprets and applies standards;
  - 3. Troubleshoots and assists with field changes;
  - 4. Monitors compliance with permit conditions;
  - 5. Monitors utilities protection;
  - 6. Monitors traffic control and pedestrian access;
  - 7. Monitors excavation, shoring, backfill and restoration, and public safety;
  - 8. Reviews the Stormwater Pollution Prevention Plan during construction;
  - 9. Reviews as-constructed drawings (record drawings).
  
- B. The Inspector has the authority to reject defective material and suspend work that is being done improperly. The Inspector may advise the Applicant or contractor of any faulty work or materials; however, failure of the Inspector to advise the Applicant or contractor does not constitute acceptance or approval. The Inspector has the authority to require revisions to approved engineering plans when necessary due to conflicting field conditions.
  
- C. The Inspector is not authorized to revise, alter, or relax the provisions of these standards. Such changes must be approved by the Director.

## 28.2. Requirements

- A. At all times during construction, the Permittee/contractor must have the issued permits and approved plans and specifications on the job site.
- B. All construction or work for which a permit is required shall be subject to inspection by the City. The City may inspect any project at any stage of the work to determine that adequate control is being exercised.
- C. Approval as a result of an inspection shall not be construed to be an approval of a violation of approved codes and City Ordinances.
- E. It shall be the duty of the permittee to cause the work to remain accessible and exposed for inspection purposes. Failure to notify the City of readiness for inspection in a timely manner may result in the requirement to remove and/or replace buried or hidden elements. The City shall not be liable for the expense entailed in the removal or replacement of any material required to allow for inspection..
- F. Site and right-of-way civil inspections may include the items listed below. Specific inspections are determined at the pre-construction meeting:
  - 1. Survey monuments;
  - 2. Survey stakes: Construction staking prior to construction. Could include contour lines of boundaries and depth of all existing floodplains, wetlands, channels, swales, streams, storm drainage systems, roads (low spots), bogs, depressions, springs, seeps, swales, ditches, pipes, groundwater, and seasonal standing water; property corners, subgrade elevations, slope (grade) stakes, right-of-way location; field verification of existing and proposed grading contours; work limits and clearing limits; or foundation forms elevations (before concrete is poured);
  - 3. Stormwater Pollution Prevention Plan installation and maintenance;
  - 4. Native vegetation protection and critical area buffers;
  - 5. Infiltration area protection;
  - 6. Staging and stockpile areas;
  - 7. Construction traffic routing; traffic control; signage and channelization;
  - 8. Surface water facilities – materials and installation;

9. Retaining walls and rockeries;
10. Utility installation, depth and location;
11. Pavement cuts;
12. Trench backfill/compaction;
13. Roadway centerline elevations;
14. Elevations at curb radii PVC's, PVI's, and PVT's;
15. Right-of-way pavement restoration;
16. Landscaping installation and restoration, plants, root barriers, and irrigation;
  - a. Clean-up;
17. Record drawing with as-constructed information;
  - a. Punch list.

Page intentionally left blank.



# APPENDIX A - ACRONYMS AND DEFINITIONS

These acronyms and definitions are for use with this Engineering Development Manual.

Unless specifically defined below, words or phrases used in this manual shall be interpreted to give them the meaning they have in common usage and to give this manual its most reasonable application.



Page intentionally left blank.



## Acronyms

AASHTO American Association of State Highway and Transportation Officials

AADT Annual Average Daily Traffic

ADA Americans with Disabilities Act

ADT Average daily trips

AIA American Institute of Architecture

APWA American Public Works Association

ASTM American Standards for Testing Materials

ATB Asphalt treated base

AWWA American Water Works Association

BMP Best Management Practices

BVC Begin of vertical curve – vertical curve

C Long Chord Length (straight line between PC and PT) – horizontal curve

CDF Controlled Density Fill

CESCL Certified Erosion and Sediment Control Lead

CFR Code of Federal Regulations

CSTC Crushed Surfacing Top Course

DNR Department of Natural Resources

DOE Washington State Department of Ecology

DOH	Washington State Department of Health
<i>e</i>	Rate of Superelevation – horizontal curve
EDM	Engineering Development Manual
ESC	Erosion prevention and sediment control
EVT	End of vertical tangent – vertical curve
FBFM	Flood boundary/floodway map
FEMA	Federal Emergency Management Agency
FIRM	Flood Insurance Rate Map
HPA	Hydraulic Project Approval
JARPA	Joint Aquatic Resource Permit Application
KCRS	King County Road Standard
KCSWDM	King County Surface Water Design Manual
<i>L</i>	Curve Length – horizontal curve
MUTCD	Manual on Uniform Traffic Control Devices, current edition
NAD	North American Datum, horizontal, of 1983/1991
NAVD	North American Vertical Datum
FIP	National Flood Insurance Program
NCHRP	National Cooperative Highway Research Program
NGVD	National Geodetic Vertical Datum of 1929
NICET	National Institute for Certification in Engineering Fundamentals

NPDES	National Pollutant Discharge Elimination System
NTU	Nephelometric Turbidity Units
OSHA	Occupational Safety and Health Administration
PC	Point of Curvature (point at which the curve begins) – horizontal curve
PCHB	Pollution Control Hearings Board
PI	Point of Intersection (point at which the two tangents intersect) – horizontal curve
PIT	Pilot Infiltration Test
PT	Point of Tangent (point at which the curve ends) – horizontal curve
PVI	Point of vertical interception (intersection of initial and final grades) – vertical curve
PW	Public Works Department
R	Radius – horizontal curve
SCL	Seattle City Light
SRD	Side Dimension Ratio
SWPE	Solid Wall Polyethylene
SWPPP	Storm Water Pollution Prevention Plan
T	Tangent Length – horizontal curve
TESC	Temporary erosion and sediment control
TSS	Total Suspended Solids
USACE	United States Army Corp of Engineers
WAC	Washington Administrative Code

WDFW Washington Department of Fish and Wildlife  
WISHA Washington Industrial Safety and Health Administration  
WSDOT Washington State Department of Transportation



## Definitions

**Access.** The safe, adequate, and usable ingress/egress (entrance/exit) between private property and the public street system. Usually defined at the right-of-way.

**Actual Elevation.** The elevation in relationship to mean sea level.

**Adverse Effect or Adverse Impact.** Effect that is a direct or indirect result of a proposed action, or its interrelated or interdependent actions, and the effect is not discountable, insignificant, or beneficial. In the event that the overall effect of the proposed action is beneficial, but is also likely to cause some adverse effects, then the proposed action is considered to result in an adverse effect.

**Alley.** A service roadway, not designed for general travel, providing a primary or secondary means of automobile, service vehicle, or emergency vehicle access to abutting property and not intended for primary traffic or pedestrian circulation.

**Alignment.** The route of the road, defined as a series of horizontal tangents and curves.

**Amenity Zone.** That area, adjacent to the curb or paved roadway and within the right-of-way, which is commonly landscaped, but may include other features for the City's benefit such as utilities, traffic signs, bioretention facilities and mailboxes.

**Applicant.** Any person, governmental agency, or other entity that executes the necessary forms to procure official approval of a project or a permit to carry out construction of a project.

**As-constructed.** Actual surveyed locations of constructed elements. As-constructed information is included on Record Drawings.

**Auxiliary Lane.** The portion of the roadway adjoining the traveled way for parking, turning or other purposes supplementary to through-traffic movement.

**Best Management Practices.** Schedules of activities, restrictions, maintenance procedures, and structural and/or managerial practices, that when used singly or in combination, prevent or reduce the release of pollutants and other adverse impacts to Waters of the State.

**Bicycle Facilities.** A general term denoting improvements and provisions to accommodate or encourage bicycling, including parking and storage facilities, and shared roadways specifically designated for bicycle use. AASHTO

**Bicycle Lane or Bike Lane.** A portion of a roadway which has been designated by pavement markings and, if used, signs, for the preferential or exclusive use of bicyclists. AASHTO

**Bicycle Path or Bike Path.** A pathway that is exclusively used by bicyclists, where a separate, parallel path is provided for pedestrians and other wheeled users. Most pathways are shared between bicyclists and other users: see Shared Use Path. AASHTO

**Bicycle Route.** A roadway or bikeway designated by the jurisdiction having authority, either with a unique route designation or with BIKE ROUTE signs, along which bicycle guide signs may provide directional and distance information. Signs that provide directional, distance, and destination information for cyclists do not necessarily establish a bicycle route.

**Bicycle Network.** A system of bikeways designated by the jurisdiction having authority. This system may include bike lanes, bicycle routes, shared use paths, and other identifiable bicycle facilities. AASHTO

**Bikeway.** A generic term for any road, street, path or way which in some manner is specifically designated for bicycle travel, regardless of whether such facilities are designated for the exclusive use of bicycles or are to be shared with other transportation modes. AASHTO

**Bicycle Shared Lane.** A lane of a traveled way that is open to bicycle travel and vehicular use.

**Bicycle Shared Roadway.** A roadway that is open to both bicycle and motor vehicle travel. This may be an existing roadway, a street with wide curb lanes, or a road with paved shoulders. AASHTO

**Bicycle Shared Use Path.** A bikeway physically separated from motorized vehicular traffic by an open space or barrier and either within the highway right-of-way or within an independent right-of-way. Shared use paths may also be used by pedestrians, skaters, wheelchair users, joggers and other non-motorized users. AASHTO

**Bicycle Shoulder.** The portion of the roadway contiguous with the traveled way, for accommodation of stopped vehicles, emergency use and lateral support of sub-base, base and surface courses, often used by cyclists where paved. AASHTO

**Bioretention Best Management Practices.** Engineered facilities that store and treat stormwater by passing it through a specified soil profile. Refer to the DOE Stormwater Manual. Volume V, Chapter 7 for bioretention practices and design specifications.

**Bulb.** Area for vehicle turnaround typically located at the end of a cul-de-sac street.

**Chlorinated.** Water that contains more than 10 mg/Liter chlorine.

**City.** The City of Shoreline.

**Clear sight triangle.** An area of unobstructed vision at street intersections or street and driveway intersections defined by lines of sight between points at a given distance from the intersection of street and/or driveway lines.

**Clearance.** The minimum distance between elements in, under and above the street right-of-way.

**Clearing.** Removal of vegetation from a site by physical, mechanical, chemical, or other means which exposes the earth's surface or any actions which disturb the existing ground surface. This does not mean landscape maintenance or pruning consistent with accepted horticultural practices.

**Comprehensive Plan.** The plan and amendments as described in SMC Chapter 20.20.

**Conveyance System.** Natural and man-made drainage features that collect, contain, and convey surface water. Natural drainage features include swales, streams, rivers, lakes, and wetlands. Man-made features include swales, gutters, ditches, pipes, and detention/retention facilities.

**Corner clearance.** The distance between a driveway and the nearest intersecting street.

**Critical areas.** Critical areas as defined in SMC Chapter 20.20.014.

**Cross section.** Vertical section of a roadway showing the position and number of vehicle and bicycle lanes and sidewalks, along with their cross slope or banking. Cross sections also show drainage features, pavement structure and other items outside the category of geometric design. Cul-de-sac. The circular turnaround at the terminus of a street end.

**Crosswalk.** The portion of the roadway between the intersection area and a prolongation or connection of the farthest sidewalk line or in the event there are no sidewalks then between the intersection area and a line 10 feet there from, except as modified by a marked crosswalk.

RCW 46.04.160

**Daily Traffic – Annual Average (AADT).** Daily traffic that is averaged over one calendar year.

**Daily Traffic – Average (ADT).** The average number of vehicles passing a specified point during a 24-hour period.

**Dangerous Waste.** Those solid wastes designated in the Washington Administrative Code (WAC) 173-303-070 through 173-303-100 as dangerous or extremely hazardous or mixed waste, as further defined under WAC 173-303-040.

**Dead End. Street End.** A road or street without an exit.

**Declaration of Covenant.** A legal document between the City and persons holding title to the property requiring the title holder to perform required maintenance and repairs on drainage facilities necessary to meet the City's specified standards within a reasonable time limit.

**Design Speed.** A selected speed used to determine the various geometric features of the roadway.

**Detention Structure.** A permanent structure designed to store runoff and discharge storage at controlled rates.

**Developer.** The person or entity that owns or holds purchase options or other development control over property for which development activity is proposed.

**Development (Land Use).** The division of a parcel of land into two or more parcels; the construction, reconstruction, conversion, structural alteration, relocation, or enlargement of any

structure; any mining, clearing, or grading; changes to surface or ground waters; or any use, change of use, or extension of the use of land. (SMC Chapter 20.20.016).

**Development (Flood).** Any man-made change to improved or unimproved real estate in the Regulatory Floodplain, including but not limited to buildings or other structures, mining, dredging, filling, grading, paving, excavation or drilling operations, storage of equipment or materials, subdivision of land, removal of more than 5% of the native vegetation on the property, or alteration of natural site characteristics. For definition related to surface water, refer to the Stormwater Manual.

**Deviation.** Written permission from the City to depart from the requirements of the Engineering Development Manual.

**Director.** The Public Works Director or designee, except that when referring to enforcement of permitting and review processes defined in SMC Chapter 20.30 Director shall mean the Director of Planning and Development Services or designee.

**Discharge.** Runoff leaving a new development or redevelopment via overland flow, built conveyance systems, or infiltration facilities. A hydraulic rate of flow, specifically fluid flow; a volume of fluid passing a point per unit of time, commonly expressed as cubic feet per second, cubic meters per second, gallons per minute, gallons per day, or millions of gallons per day..

**Drainage Facility.** A constructed or engineered feature that collects, conveys, stores, or treats stormwater runoff. "Drainage facility" includes, but is not limited to, a constructed or engineered stream, pipeline, channel, ditch, gutter, lake, wetland, closed depression, flow control or water quality treatment facility, erosion and sediment control facility and other structure and appurtenance that provides for drainage.

**Drainage.** Collection, conveyance, containment, and/or discharge of surface water and stormwater runoff.

**Driveway.** The on-site portion of an access to a property. Driveway is privately owned and maintained.

**Driveway – Approach.** That area between the pavement edge of the intersecting street and the right-of-way/property line.

**Driveway – Apron.** See Driveway – Approach.

**Driveway – Shared.** A jointly owned and maintained tract or easement serving two properties.

**Easement.** A grant by the property owner of the use of a strip of land by the public, corporation or persons for specific purposes. Emerging Technologies. Treatment technologies that have not been evaluated with Department of Ecology-approved protocols, but for which preliminary data indicate that they may provide a necessary function(s) in a stormwater treatment system.

**Engineer – Geotechnical.** A practicing, professional civil engineer licensed by the State of Washington, who has knowledge and practice of geotechnical engineering.

**Engineer – Professional.** An engineer, licensed to practice in the State of Washington as a Professional Engineer.

**Engineer – Soils.** Geotechnical Engineer.

**Engineering – Geotechnical.** The application of soil mechanics in the investigation, evaluation, and design of civil works involving the use of earth materials and the inspection or testing of the construction thereof.

**Engineering Geologist.** A geologist certified by the State as experienced and knowledgeable in engineering geology.

**Engineering Geology.** The application of geologic knowledge in the investigation and evaluation of naturally occurring rock and soil for use in the design of civil works.

**Eyebrow.** A partial bulb located adjacent to the serving road that provides access to lots and serves as a vehicle turnaround.

**Financial Guarantee.** A surety, bond, cash deposit, escrow account, any assignment of funds, irrevocable letter of credit, or other means acceptable to the City to guarantee acceptable performance, execution, completion of the work and maintenance, in accordance with the project's approved plans and in accordance with all applicable governmental requirements.

**Fire Apparatus Access Road.** As defined in the International Fire Code.

**Fire Lane.** As defined in the International Fire Code.

**Fixed Object.** An object having properties greater than a four-inch by four-inch wooden post.

**Flow Attenuation.** Detaining or retaining runoff to reduce the peak discharge.

**Frontage.** Any lot line abutting street right-of-way.

**Frontage Improvements.** Motorized and nonmotorized facilities, transit facilities, utilities, landscaping, and other such features located within the public right-of-way.

**Grading.** See Land Disturbing Activity.

**Ground Disturbance.** See Land Disturbing Activity.

**Guarantee.** A surety bond, cash deposit, escrow account assignment of savings, irrevocable letter of credit or other means acceptable to, or required by, the Director to guarantee work is in compliance with all applicable requirements. SMC Chapter 20.50.

**Half-Street.** A street constructed utilizing at least half the regular width of the right-of-way and permitted as an interim facility pending construction of the other half.

**Hard Surface** – An impervious surface, a permeable pavement, or a vegetated roof.

**Impervious Surface.** A non-vegetated surface area which either prevents or retards the entry of water into the soil mantle as under natural conditions prior to development. A non-vegetated area which causes water to run off the surface in greater quantities or at an increased rate of flow from those present under natural conditions prior to development. Common impervious surfaces include, but are not limited to, roof tops, walkways, patios, driveways, parking lots or storage areas, concrete or asphalt paving, gravel roads, packed earthen materials, and oiled macadam or other surfaces which similarly impede the natural infiltration of stormwater. Open, uncovered retention/detention facilities shall not be considered as impervious surfaces for the purposes of determining whether the thresholds for application of minimum requirements are exceeded. Open, uncovered retention/detention facilities shall be considered impervious surfaces for purposes of runoff modeling.

**Improvements.** Any improvement to public, real, or personal property, including but not limited to, installation of streets, roads, pedestrian/bike facilities, streetlights, landscape features, sewer and waterlines, bridge structures, storm drainage facilities, and traffic control devices.

**Infiltration.** The downward movement of water from the surface to the subsoil.

**Inspector.** Designee of the Public Works Director.

**Internal Road.** A road that is contained within the development.

**Intersection.** The area from the intersection of a roadway to the radius tangent point or stop bar on each approach, whichever is greater.

**Land Disturbing Activity.** For the purposes of this Engineering Development Manual and SMC Chapter 13.10. Any activity that results in movement of earth, or a change in the existing soil cover (both vegetative and non-vegetative) and/or the existing soil topography. Land disturbing activities include, but are not limited to clearing, grading, filling, and excavation. Compaction that is associated with stabilization of structures and road construction shall also be considered a land disturbing activity. Vegetation maintenance practices are not considered land disturbing activity. Stormwater facility maintenance is not considered land disturbing activity if conducted according to established standards and procedures.

**Land Surveying.** Establishment of corners, lines, boundaries, and monuments, the laying out and subdivision of land, the defining and locating of corners, lines, boundaries and monuments of land after they have been established, the survey of land areas for the purpose of determining the topography thereof, the making of topographical delineations and the preparing of maps and accurate records thereof, when the proper performance of such services requires technical knowledge and skill.

**Landing.** A road or driveway approach area to any public or private road or intersection.

**Loop.** Road of limited length forming a loop, having no other intersecting road, and functioning mainly as direct access to abutting properties. A loop may be designated for one-way or two-way traffic.



**LID Best Management Practices** – Distributed stormwater management practices, integrated into a project design, that emphasize pre-disturbance hydrologic processes of infiltration, filtration, storage, evaporation and transpiration. LID BMPs include, but are not limited to, bioretention/rain gardens, permeable pavements, roof downspout controls, dispersion, soil quality and depth, minimal excavation foundations, vegetated roofs, and water re-use.

**Low Impact Development (LID).** A stormwater and land use management strategy that strives to mimic predisturbance hydrologic processes of infiltration, filtration, storage, evaporation and transpiration by emphasizing conservation, use of on-site natural features, site planning, and distributed stormwater management practices that are integrated into a project design.

**Low Impact Development (LID) Principles.** Land use management strategies that emphasize conservation, use of on-site natural features, and site planning to minimize impervious surfaces, native vegetation loss, and stormwater runoff.

**Maintenance** – Repair and maintenance includes activities conducted on currently serviceable structures, facilities, and equipment that involves no expansion or use beyond that previously existing and results in no significant adverse hydrologic impact. It includes those usual activities taken to prevent a decline, lapse, or cessation in the use of structures and systems. Those usual activities may include replacement of dysfunctional facilities, including cases where environmental permits require replacing an existing structure with a different type structure, as long as the functioning characteristics of the original structure are not changed. One example is the replacement of a collapsed, fish blocking, round culvert with a new box culvert under the same span, or width, of roadway. In regard to stormwater facilities, maintenance includes assessment to ensure ongoing proper operation, removal of built up pollutants (i.e. sediments), replacement of failed or failing treatment media, and other actions taken to correct defects as identified in the maintenance standards of Chapter 4, Volume V of the *SMMWW*. See also Pavement Maintenance exemptions in Section 1 of this Appendix.

**Municipal Separate Stormwater System (MS4).** A conveyance, or system of conveyances (including roads with drainage systems, municipal streets, catch basins, curbs, gutters, ditches, manmade channels, or storm drains), owned or operated by the state, City, county, or special purpose district having jurisdiction over disposal of wastes, stormwater, or other wastes, or a

designated and approved management agency under section 208 of the CWA that discharges to waters of the United States; designed or used for collecting or conveying stormwater; which is not a combined sewer; and which is not part of a Publicly Owned Treatment Works (POTW) as defined at 40 CFR 122.2.

**National Pollutant Discharge Elimination System (NPDES).** The national program for issuing, modifying, revoking, and reissuing, terminating, monitoring and enforcing permits, and imposing and enforcing pretreatment requirements, under sections 307, 402, 318, and 405 of the Federal Clean Water Act, for the discharge of pollutants to surface waters of the state from point sources. These permits are referred to as NPDES permits and, in Washington State, are administered by the Washington Department of Ecology.

**Native vegetation** –Vegetation comprised of plant species, other than noxious weeds, that are indigenous to the coastal region of the Pacific Northwest and which reasonably could have been expected to naturally occur on the site. Examples include trees such as Douglas Fir, western hemlock, western red cedar, alder, big-leaf maple, and vine maple; shrubs such as willow, elderberry, salmonberry, and salal; and herbaceous plants such as sword fern, foam flower, and fireweed.

**Nephelometric Turbidity Units.** These units are a quantitative measure of water clarity based on the scattering of a standard beam of light directed into a standard sample of the water when the scattering is measured at right angle to the beam. A higher reading means the sample is cloudier. See also the definition for “turbidity” included below.

**Off-Street Parking Space.** An area accessible to vehicles, exclusive of right-of-way, that is improved, maintained, and used for the purpose of parking a motor vehicle.

**Operation and Maintenance Plan.** A set of instructions and schedules to keep drainage facilities working to meet the design performance criteria.

**Outfall** means point source as defined by 40 CFR 122.2 at the point where a discharge leaves the MS4 and discharges to waters of the State. Outfall does not include pipes, tunnels, or other conveyances which connect segments of the same stream or other surface waters and are used to convey primarily surface waters (i.e. culverts).

**Pavement Width.** Paved area on shoulder-type roads or paved surface between curb, thickened edge, or gutter flow line on all other roads.

**Performance Guarantee.** A financial guarantee in a form acceptable to the City, ensuring that all improvements, facilities, or work will be completed in compliance with regulations, and approved plans and specifications.

**Permeable pavement** – Pervious concrete, porous asphalt, permeable pavers or other forms of pervious or porous paving material intended to allow passage of water through the pavement section. It often includes an aggregate base that provides structural support and acts as a stormwater reservoir.

**Permittee.** Any person, governmental agency, or other entity that is performing, or plans to perform, permitted work within the City.

**Pipe Stem.** A strip of land having a width narrower than that of the lot or parcel to be served and is designed for providing access to that lot or parcel.

**Plans.** The plans, profiles, cross sections, elevations, details, and supplementary specifications showing the location, character, dimensions, and details of the work to be performed.

**Pollution.** Contamination or other alteration of the physical, chemical, or biological properties of waters of the state that will or is likely to create a nuisance or render waters harmful, detrimental, or injurious 1) to public health, safety, or welfare, or 2) to domestic, commercial, industrial, agricultural, recreational, or other legitimate beneficial uses, or 3) to livestock, wild animals, birds, fish, or other aquatic life. Contamination includes discharge of any liquid, gas, or solid, radioactive, or other substance. Alteration includes temperature, taste, color, turbidity, or odor.

**Project Manager.** City of Shoreline staff member responsible for review of a development project.

**Project.** Activity encompassing all phases of the work to be performed and is synonymous to the term “improvement” or “work.”

**Project site** That portion of a property, properties, or right-of-ways subject to land disturbing activities, new hard surfaces, or replaced hard surfaces..

**Profile.** When referring to roadway design: Vertical aspect of the road, including crest and sag curves, and the straight grades connecting them.

**Rainy Season.** The period starting on October 1 of each year and ending April 30 of each following year. These dates may be adjusted by the Director based on climatic conditions for a particular year.

**Receiving waters** Naturally and/or reconstructed naturally occurring surface water bodies, such as creeks, streams, rivers, lakes, wetlands, estuaries, and marine waters, or groundwater, to which a municipal separate storm sewer discharges.

**Record Drawings.** Drawings that document as-constructed conditions of a permitted development or redevelopment project.

**Redevelopment.** For surface water purposes: on a site that is already substantially developed (i.e., has 35 percent or more of existing impervious surface coverage), the creation or addition of impervious surfaces; the expansion of a building footprint or addition or replacement of a structure; structural development including construction, installation or expansion of a building or other structure; replacement of impervious surface that is not part of a routine maintenance activity; and land disturbing activities.

**Replaced hard surface:** For structures, the removal and replacement of hard surfaces down to the foundation. For other hard surfaces, the removal down to bare soil or base course and replacement.

**Replaced impervious surface** – See “replaced hard surface.” .

**Right-of-way.** Property granted or reserved for, or dedicated to, public use for street purposes and utilities, together with property granted or reserved for, or dedicated to, public use for walkways, sidewalks, bikeways, and parking whether improved or unimproved, including the air rights, sub-surface rights and easements thereto.

**Road.** Interchangeable with “Street”.

**Runoff.** Water that travels across the land surface and discharges to water bodies either directly or through a collection and conveyance system. See also “Stormwater.” Sediment. soils or other materials transported or deposited by the action of wind, water, ice, or gravity.

**.Shoulder.** The paved or unpaved portion of the roadway outside the traveled way that is available for parking or non-motorized use.

**Sidewalk.** All hard-surface walkways within public rights-of-way or a public easement in the area between the street margin and the roadway, including driveways. (20.20.046 – Sidewalks not always in right-of-way?)

**Sight Distance.** The distance along a roadway throughout which an object of specified height is continually visible. This distance depends on the height of the driver’s eye above the road surface, the height of the specified object above the road surface, and the height and lateral positions of obstructions within the driver’s line of sight. (AASHTO A Policy on Geometric Design)

**Site Plan.** The development plan for one or more lots on which is shown the existing and proposed conditions of the lot, topography, vegetation, drainage, flood plains, walkways; means of ingress and egress; circulation; utility services; structures and buildings; signs and lighting; berms, buffers, and screening devices; surrounding development; or any other information that reasonably may be required in order that an informed decision can be made by the reviewing authority.

**Sight Distance – Stopping.** The distance needed for a driver to perceive and react to a discernible hazard and then brake to a stop before reaching the hazard. (Urban Street Geometric Design Handbook, ITE)

**Sight Distance – Intersection.** The distance needed to safely make a right turn or a left turn from an access or to a cross street, or for a driver to safely make a left turn from a street to an access. (Urban Street Geometric Design Handbook, ITE)

**Sight Distance – Decision.** The distance needed for a driver to ascertain and safely respond to an unexpected difficult or unfamiliar situation. Regarding access location, sight distance should

give familiar and unfamiliar drivers enough distance to safely turn into the desired access.  
(Transportation Research Board, 2003. Urban Street Geometric Design Handbook, ITE)

**Site.** Any tract, lot, or parcel of land, or combination of tracts, lots, or parcels of land which are in one ownership, or are contiguous and in diverse ownership, where development is to be performed as a part of a unit, subdivision, or project.

**Special Drainage Areas.** An area which has been formally determined by the City to require more restrictive regulation than Citywide standards afford in order to mitigate severe flooding, drainage, erosion or sedimentation problems which result from the cumulative impacts of development.

**Stabilization.** The prevention of soil movement by any various vegetative and/or structural means.

**Storm Drainage Plan.** A set of drawings and documents submitted as a prerequisite to obtaining a development permit. The plan contains all of the information and specifications pertaining to surface water management on-site and offsite.

**Stormwater** Water runoff during and following precipitation and snowmelt events, including surface runoff, drainage or interflow.

**Stormwater Manual.** The most recent version of the Stormwater Management Manual for Western Washington published by Washington Department of Ecology adopted in Chapter 19.

**Street.** A public or recorded private thoroughfare providing pedestrian and vehicular access through neighborhoods and communities and to abutting property.

**Street – Arterial.** Provides a high degree of vehicular mobility by limiting property access. The vehicles on arterials are predominantly for through traffic. Arterials are generally connected with interstate freeways or limited access expressways.

**Street – Arterial – Collector.** Connect traffic from the interior of an area/community to the closest Minor or Principal Arterials.

**Street – Arterial – Minor.** Provide intra-community connections and are less significant from a perspective of a regional mobility.

**Street – Arterial – Principal.** Provide major vehicular travel routes between cities within a metropolitan area.

**Street – Non-Arterial.** Provide local access to residential areas. Shoreline classifies local streets as Neighborhood Collectors or Local Streets.

**Street – Local Primary.** Connect local streets to Collector Arterials.

**Street – Local Secondary.** Provides local access connections to higher classification streets.

**Street – Private.** A privately-owned and maintained access provided for by a tract, easement or other legal means.

**Surface Water or Stormwater.** Water originating from rainfall and other precipitation that is found on ground surfaces and in drainage facilities, creeks, rivers, streams, springs, seeps, ponds, lakes, wetlands, as well as shallow ground water.

**Surveyor.** A person licensed by the State of Washington to engage in the practice of land surveying, as defined by RCW 18.43.020.

**Threshold Discharge Area.** An on-site area draining to a single natural discharge location or multiple natural discharge locations that combine within one-quarter mile downstream (as determined by the shortest flowpath.) The purpose of this definition is to clarify how the thresholds of the Stormwater Manual are applied to project sites with multiple discharge points.

**Traveled Way.** The part of the road made for vehicle travel excluding shoulders and auxiliary lanes.

**Turbidity Meter.** A portable, electric, hand-held measuring device designed to give a numerical value of the turbidity (cloudiness) of a sample of water. The numerical values are expressed in units known as Nephelometric Turbidity Units (NTUs).

**Turbidity.** The visual cloudiness of the runoff especially as caused by suspended solids and settle-able solids that are being carried by the runoff.

**Utility.** Private or municipal corporations owning or operating, or proposing to own or operate facilities that comprise a system or systems for public service. Private utilities include gas, electric, telecommunications, or water companies that are subject to the jurisdiction of the State Utilities and Transportation Commission and that have not been classified as competitive by the commission.

**Waters of the State.** those waters as defined as "waters of the United States" in 40 CFR Subpart 122.2 within the geographic boundaries of Washington State and "waters of the state" as defined in chapter 90.48 RCW which includes lakes, rivers, ponds, streams, inland waters, underground waters, salt waters and all other surface waters and water courses within the jurisdiction of the State of Washington.



# APPENDIX B - SURVEY CRITERIA



Page intentionally left blank.



## Survey Format and Content

The following applies to surveys performed for development projects. Contact Planning and Community Development for land use surveys requirements. A survey acceptable to the City must contain the elements listed below. Review of the survey will be done as part of the plan review process.

1. The surveyor's stamp, signature, contact information and the date signed (see Note 1)
2. North arrow, graphic scale, legend, and vicinity map
3. Legal Description, if needed (see Note 2)
4. NAVD 88 and NAD83/91 are required (see Note 3)
5. Monuments within the project area (see Note 4)
6. Site benchmarks (see Note 5)
7. Rights-of-way with dimensions, source references, and methods used to determine (see Note 6)
8. Easements with type, dimensions, and source references (see Note 7)
9. Property lines with bearings and distances (see Note 8)
10. Buildings (see Note 9)
11. Streets and street improvements (see Note 11)
12. Utilities (see Note 11)
13. Contours (see Note 12)
14. Steep slopes (See Note 13)
15. Topography (see Note 14)
16. Significant Trees (see Note 15)

17. Water features (see Note 16)
18. Protected areas, if required, including wetland boundaries (see Note 17)
19. Setbacks (see Note 18)
20. Underground hazards (see Note 19)
21. Any monuments in the project area that may be disturbed, destroyed, or removed shall be noted on the plans as requiring replacement. An application for a permit to remove or destroy a survey monument must be filed with the Washington State Department of Natural Resources, pursuant to RCW 58.24.040(8). Under such conditions add Note 21 to General Notes on plan (see Note 20).

#### Survey Requirements Notes

**Note 1. Land Surveyor's Stamp** – Work consisting of the Practice of Land Surveying shall be done by or under the direction of a Surveyor licensed to practice in the State of Washington (RCW 18.43.010), and shall conform to all RCWs and WACs pertaining to surveying and engineering. Plans, specifications, plats and reports prepared by the Surveyor shall be signed, dated and stamped with the Surveyors' seal. (RCW 18.43.070) Washington State law defines the "practice of land surveying" as "assuming responsible charge of the surveying of land for the establishment of corners, lines, boundaries, and monuments, the laying out and subdivision of land, the defining and locating of corners, lines, boundaries and monuments of land after they have been established, the survey of land areas for the purpose of determining the topography thereof, the making of topographical delineations and the preparing of maps and accurate records thereof, when the proper performance of such services requires technical knowledge and skill." (RCW 18.43.020(9))

**Note 2. Legal Description** – Legal Descriptions are needed for plats, short plats, easements containing City utilities, etc. Include the plat name or short plat number, block number if any, and lot number or parcel letter, or the meet's and bounds description of the parcel.

**Note 3. Data** – The Washington State Lambert Grid Coordinate System North Zone, using the NAD83 (1991) datum as established in accordance with Chapter 58.20

Revised Code of Washington. The unit of measurement shall be the U.S. Survey Foot. The plans shall show the horizontal control used to establish ties to the datum, with type, size, and location, date visited, and the State Plane coordinates for each monument used. Show at least two monuments on each street in the project.

Project control may be shown in the design drawings, or on its own sheet. The Vertical datum for all survey work (including but not limited to mapping, platting, planning design, right-of-way surveys, and construction surveys) shall be the North American Vertical Datum of 1988 (NAVD 1988). The plans shall show the benchmarks used to establish ties to the datum, with reference number, description, location and elevation of each benchmark used, and any project site benchmarks. Information on horizontal and vertical control monuments can be found in the Washington Council of County Surveyors Data Warehouse at <http://plso.wadnr.gov/surveycontrol/data.htm>.

Other acceptable sources for benchmarks are WSDOT, King County, and NOAA. When another benchmark is used, establish one benchmark for each datum and show on the plans. Include a local conversion factor between the two data. The benchmark used to establish the conversion factor must be the benchmark nearest to the project site.

**Note 4. Monuments** – The plans shall show all monuments, geometry and references used to establish the right-of-way, lines referencing the right-of-way, property lines, easements and any rights in real property shown. The plans shall show bearing and distance on monument lines, or radius, delta angle, and curve length on curving monument lines, and the station at each monument. If construction baselines other than the monument line are used, show the relation of each baseline to the monument line. Survey control and boundary information may be shown on the design drawings, the vicinity map, or on its own sheet.

**Note 5. Benchmarks** – Show site benchmarks. Project site benchmarks shall be established by measurement from two local benchmarks, meeting Third Order procedural requirements as specified in the Geospatial Positioning Accuracy Standards by the Federal Geographic Data Committee. Site benchmarks shall be set in a location that will not be disturbed by the proposed construction.

**Note 6. Rights-of-way** – Show the width on each side of the monument line, and the references used. If the right-of-way is of variable width, show the width at each end of the block.

**Note 7. Easements** – Show easements Native Growth Retention Areas, and critical area buffers within the project area, with type, dimensions, and source reference.

**Note 8. Property Lines** – Show bearings and distances for straight property lines, and radius, delta angle, and arc length for curves.

**Note 9. Buildings** – Show the location of all existing buildings, including projections, roof overhangs, and covered breezeways. Show the perpendicular distance to the property and right-of-way lines when significant to development. Show footprints of recently demolished buildings.

**Note 10. Streets** – Show the right-of way lines, monument lines, concrete surfaces, asphalt surfaces, gravel surfaces, and channelization, centerlines, pavement edges, pavement widths, shoulders, ditch lines, curbs, sidewalks, and access locations.

Show the curbs, curb cuts, wheelchair ramps, gutter and flow lines, sidewalks, landscape areas, pedestrian and bike paths.

**Note 11. Utilities** – Field locate and show all visible utilities, structure, and appurtenances. Show buried utilities and the source of the information used. Show the location, size, and description of all utilities including water, power, sewer, and storm drainage systems and appurtenances. Show elevations at rim and inverts of manholes, catch basins, and inlets. Locate and dimension all fire hydrants, vaults, utility poles, etc.

**Note 12. Contours** – Show existing and proposed contours at 2-foot intervals for portions of the site with slopes greater less than 40 percent, and for those areas exceeding 40 percent that will be graded. Show 5-foot intervals for portions of the site with slopes that exceed 40percent but will not be disturbed.

**Note 13. Steep Slopes** – Identify slopes 15 percent and steeper. Show the top of slopes 40 percent or steeper.



**Note 14. Topography** – Show rockeries, retaining walls, fences, bridges, swales, culverts, etc. Show the location, length, and height above finished grade of all fences, rockeries, and retaining walls. Note heights at end and mid points.

**Note 15. Significant Trees** – Show evergreen trees that are eight inches or more in diameter and deciduous trees that are twelve inches or more in diameter. Diameter is measured four feet above existing grade. Label each tree with common name and diameter. Show drip lines.

**Note 16. Water Features** – Show lakes, rivers, streams, ditches, ponds, and other surface water features. Show the line of ordinary high water and the top of any well-defined banks. Show the 100-year floodplain, and show wetland boundaries. Show protected areas: top of bank of Type 1, 2, and 3 streams, and the centerline of Type 4 streams.

**Note 17. Environmentally Sensitive Areas** – Show areas defined in Shoreline's Critical Areas Ordinance (SMC Chapter 20.80). If the survey shows protected areas on or adjacent to the site, contact the Department of Planning and Community Development for boundary verification prior to designing the project.

**Note 18. Setbacks** – Show the required primary setbacks from the protected areas.

**Note 19. Underground Hazards** – Show areaways, tunnels, mines and other underground hazards.

**Note 20. Survey Monuments** – Survey Monuments shall not be removed, disturbed, covered, or destroyed before a permit is obtained from the Washington State Department of Natural Resources. At least four working days before a monument is removed, disturbed, covered, or destroyed, provide a copy of the DNR permit to the City representative assigned to the project.



# APPENDIX C - SURFACE WATER REPORT GUIDELINES



Page intentionally left blank.



## Surface Water Report Guidelines

The surface water report is a comprehensive supplemental report containing all technical information and analyses related to storm drainage/surface water design for a project. Any project triggering Minimum Requirements #1 - #5 (non single-family) or Minimum Requirements #1 - #9, requires a surface water report meeting the criteria of this appendix.

The surface water report must be prepared, stamped and dated by an engineer licensed in Washington State.

The attached report outline describes the contents for each element in the surface water report. The actual content under each element will depend on the complexity of the project and site conditions.

The report submitted to the City must address each element in the outline. If a section does not apply, the engineer may simply mark "N/A" with a brief explanation. This standardized format allows a quicker, more efficient review of information required to supplement the site improvement plan.

When the report requires revisions, the revisions must be submitted in a complete revised report.

Submit two copies of the bound, 8.5" x 11" report. Figures and drawings may be on larger paper. Figures and drawings larger than 11" x 17" should be provided separately from the bound document.

**Please use double-sided printing for the report.**

**Number each page.**

### COVER SHEET

The cover sheet has the:

Project name and address;

Applicant's name, address, and telephone number;

Engineering firm's name, address, and contact information;

Engineer's name and license number;

Report date and revision dates.

## TABLE OF CONTENTS

Show the page number for each section of the report, including appendices.

## SUMMARY SHEET

Include a completed City of Shoreline summary sheet.

## PROJECT OVERVIEW

Introduce the formal project name, address and parcel numbers.

Briefly describe the proposal, redeveloped and developed site conditions, site and project site area, sizes of proposed improvements, and the disposition of stormwater runoff before and after development. The project overview must provide a general description of the project, redeveloped and developed conditions of the site, site area and size of the improvements, and the pre- and post-developed stormwater runoff conditions. The overview should summarize difficult site parameters, the natural drainage system, and drainage to and from adjacent properties, including bypass flows. Include drainage requirements and restrictions from other agencies.

## MINIMUM REQUIREMENTS

Discuss minimum requirements that apply to the project, as well as additional requirements from basin plans, critical areas, plat/short plat approvals, conditional use permits, and SEPA mitigations. Discuss any engineering deviations and any specific site conditions that affect design requirements. Discuss any assumptions used in design.

## SITE AND BASIN ASSESSMENT

The site assessment provides the baseline information necessary to preserve natural resources, preserve areas most appropriate to evaporate, transpire, and infiltrate stormwater, and help to achieve the goal of maintaining or restoring predevelopment natural hydrologic conditions on the site.



Describe existing conditions including relevant hydrologic conditions. The discussion should include hydrology, topography, soils, vegetation, water features, and drainage patterns. Include site visit dates, observations, and weather.

Describe the following:

Topography

Existing ground cover, including pervious, impervious, and pollution generating areas

Describe the natural features of the parcel (i.e., woods, pasture, and brush) and give the approximate area covered by those features

Offsite drainage to the property

Creeks, lakes, ponds, wetlands, ravines, gullies, steep slopes, springs, and other environmentally sensitive areas on or down gradient of the property

Drains, channels, and swales, within the project site and immediately adjacent

Points of exit for existing drainage from the property

Any known historical drainage problems such as flooding, erosion, etc.

Existing Structures/Improvements: List any existing buildings, driveways (dirt, gravel, etc.), sidewalks, etc. and their area size in square feet or acres

New Structures Improvements: List new buildings and their sizes along with any size changes in existing driveways, parking areas, landscaped areas, etc

Future Structures/Improvements Planned: If you wish to have drainage review waived for future structures/improvements on this parcel, you must list them (with dimensions) in this section. Show their locations on the plot plan

Remaining Undisturbed Land: List and provide the size of the land (woods, pasture) not covered by buildings or improvements.

### **3.1 Phased Offsite Analysis**

Provide the results of phased offsite analysis performed according to the Stormwater Manual Volume I: 3.1.3 and Volume I: 2.6.2. Include the level of analysis, results for the upstream and downstream analyses. The analysis may include evaluation of impacts to fish habitat, groundwater levels, groundwater quality, or other environmental features expected to be significantly impacted by the proposed project due to its size or proximity to such features.

### **3.2 Sub-basin Description**

Describe offsite drainage tributary to the project. Describe any bypass drainage from the project which will not be controlled. Describe the drainage system between the site and the receiving surface waters. Include results for the upstream and downstream analyses.

### **3.3 Soils/Infiltration Rates**

Discuss soils. Provide results of PIT test, including observations made during the tests. Because soil classifications and D10 particle size are not adequate to estimate infiltration rates, short-term and long-term infiltration rates must be determined by on-site infiltration tests. Infiltration testing can be performed by a licensed geologist, licensed engineer, licensed hydrogeologist, licensed engineering geologist, or professional soil scientist certified by the Soil Science Society of America (or equivalent national program).

Sites in the Medium Impact project classification may use a licensed on-site sewage designer for preparation of the soils analysis.

Subdivision projects may need to evaluate the soils on each lot for infiltration BMP applicability.

### **3.4 Critical Areas and Flood Plain**

Discuss all critical areas and buffers within and adjacent to the site. If the project is within the potential flood hazard area as defined in the Thornton Creek Watershed Plan, show the 100-year flood hazard area on the plans.

### **3.5 Assessment Summary**

This section should define the study area, describe the drainage system (including conveyance), identify problems, and define mitigation. Figure 2 should represent the information contained in the site assessment and summary.

Summarize evaluation of impacts to fish habitat, groundwater levels, groundwater quality, or other environmental features expected to be significantly impacted by the proposed project due to its size or proximity to such features. Describe proposed mitigation for the impacts.

Provide all assumptions used.

Identify and discuss difficult site parameters and how the plan incorporates the following criteria:

Conserve existing habitat and vegetation.

Protect areas conducive to infiltration and preserve these areas during site design and construction.

Limit ground disturbance areas to road, utility, building pad, landscape areas, and the minimum additional area needed to maneuver equipment. (A 10-foot perimeter around the building site can provide adequate work space for most activities.)

Reduce impervious surfaces.

Place structures as close to the public access point as possible to minimize road/driveway length.

Limit vehicular and pedestrian infrastructure, such as roads, driveways, parking areas and sidewalks, to the minimum functional needs.

Utilize porous paving options wherever possible.

Slope paved areas to facilitate drainage to stormwater management areas.

Reduce building footprints whenever possible. Utilize basements or taller structures with lofts or second stories to achieve square footage goals.

Orient buildings on slopes with long-axis along topographic contours to reduce grading requirements.

Amending disturbed soils according to BMP T5.13 in the Stormwater Manual: Volume V. (Required on most sites)

### **3.6 Facility Sizing and Downstream Analysis**

Include references to relevant reports such as basin plans, flood studies, groundwater studies, wetland designations, sensitive area designations, environmental impact statements, environmental checklists, lake restoration plans, water quality reports, etc. Where such reports impose additional conditions on the Applicant, state these conditions and describe any proposed mitigation measures.

## CONSTRUCTION STORMWATER POLLUTION PREVENTION PLAN

An adequate construction stormwater pollution prevention plan (SWPPP) includes both a narrative and drawings. Describe how each of the 13 Elements in a SWPPP are being met, where and when the various BMPs should be installed, expected performance of each BMP, and actions to be taken if the performance goals are not achieved.

State the name and contact information of the SWPPP Supervisor or Certified Erosion and Sediment Control Lead (CESCL) (see EDM Section 25.2).

### 4.1 Rainy Season Requirements

Describe how the rainy season requirements for land disturbing work from October 1 to April 30 will be met.

### 4.2 Seasonal Suspension Plan

When rainy season construction is prohibited, describe the Seasonal Suspension Plan.

## PERMANENT STORMWATER CONTROL

Describe how natural drainage systems and outfalls will be preserved.

Describe design measures taken to create facilities that are aesthetically pleasing, how facilities will provide useable open space, and how the facilities will fit into the landscaping plan for the property, and how the facilities are in keeping with any approved community plan.

Describe how utilities will be installed to ensure no conflicts with proposed stormwater quantity and quality control measures.

### 5.1 Low Impact Development and Flow Control

Describe the flow control system, including Low Impact Development techniques and BMPs, outlet works and spillways, flow path lengths, and the safety factors used.

List the method used to comply with Minimum Requirement #5 (List #2 or the Low Impact Development Performance Standard).

If flow control BMP credits are used, explain how the credits will be used and how the criteria for use of credits will be met. If the flow control system is an infiltration facility, provide the soils data, groundwater mounding analysis, or other calculations used to determine the design infiltration rate.

Provide a table that identifies the design facility stage expected for the 2-, 5-, 10-, 25-, 50-, and 100-year recurrence interval flows.

## **5.2 Water Quality**

This section should list receiving waters and pollutants of concern, discuss oil control facilities, describe the selection process for treatment options, and discuss how the water quality plan meets required enhanced treatment.

## **5.3 Source Control**

Pollution source control is the application of pollution prevention practices on a developed site to reduce contamination of stormwater runoff at its source. List the possible sources of pollution after construction. Provide supporting information (site conditions, calculations, etc.) for the selection and sizing of pollution prevention BMPs.

## **5.4 Conveyance System Analysis and Design**

Describe capacities, design flows, and velocities. Specify materials for the design (e.g., rock lining for channels when velocity is exceeded; high density polyethylene pipe needed for steep slope). Present analysis in a clear, concise manner that can be easily followed, checked, and verified.

## **SPECIAL REPORTS AND STUDIES**

Cite special reports and studies used as reference when preparing the Stormwater Site Plan(s), such as the following:

- Critical areas analysis and delineation
- Geotechnical/soils
- Structural design

Structural fill

## OTHER PERMITS

Include a list of other necessary permits and approvals as required by other regulatory agencies, if those permits or approvals include conditions that affect the surface water plan, or contain more restrictive drainage-related requirements.

## PROJECT ENGINEER'S CERTIFICATION

The surface water report shall contain a page with the project engineer's seal, signature, and date signed, with the following statement:

"I hereby state that this surface water report for \_\_\_\_\_  
(name of project) has been prepared by me or under my supervision and meets the standard of care and expertise which is usual and customary in this community for professional engineers. I understand that the City of Shoreline does not and will not assume liability for the sufficiency, suitability, or performance of drainage facilities prepared by me."

## FIGURES

The following documents are required. Additional figures may be provided.

### **Figure 1. Vicinity Map**

A vicinity map should clearly locate the property and any pertinent locations near the site.

### **Figure 2. Site Assessment and Summary**

Figure 2 should represent the information contained in the site assessment and summary. Provide a map at a scale that clearly shows the contour intervals and other information. At a minimum the map shall show the following:

Topography

The direction of flow, for all drainage

Boundaries of basins, sub basins, the site and the project site

Acreage of sub basins and areas contributing runoff to the site

Existing discharge points to and from the site  
Downstream drainage system for the distance of the downstream analysis  
Locations of existing utilities, existing improvements, and access  
Critical areas, natural streams and drainage features on and adjacent to the site  
Areas that cannot be developed due to conditions such as slopes or critical area buffers  
Areas to be preserved (infiltration, vegetation, soils).

### **Figure 3. Site Development**

The drainage design on the construction drawings can substitute for this figure.

### **Figure 4. Planting Plan**

Provide a planting plan and specifications for each vegetated facility.

## **APPENDICES**

### **Appendix A – Infiltration Testing**

Provide the results of the PIT testing. Include on-site observations of soils and groundwater. All test reports must be signed and dated, with credentials and license number or certification number for person or persons responsible for performing the testing. Include a site plan showing locations of PIT test(s).

### **Appendix B – Geotechnical Report**

Include a copy of the geotechnical report prepared for the project site.

### **Appendix C – Documentation**

Provide the methods used for analysis, and information showing that facilities meet the performance standards. Include all supporting documentation such as assumptions, computer printouts, calculations, equations, references, storage/volume tables, duration analyses, graphs, and any other aides necessary to clearly show results used to design flow control and water quality facilities.

### **Appendix D – Maintenance Plan**

The importance of maintenance for the proper functioning of stormwater control facilities cannot be over-emphasized. A substantial portion of failures (clogging of filters, re-suspension of sediments, loss of storage capacity, etc.) of such facilities is due to inadequate maintenance. In accordance with Minimum Requirement #9, a maintenance plan must be developed for projects that use permeable pavement, bioretention, or any flow control or water quality facility.

At private facilities, a copy of the plan shall be retained on-site or within reasonable access to the site, and shall be transferred with the property to the new owner. For public facilities, a copy of the plan shall be retained in the appropriate department.

Note that, per Volume III, all detention and infiltration facilities (including detention vaults) are required to include a crest gauge that will record maximum pond water surface elevation after a storm event. In addition, project submittals must include a table that identifies the design facility stage expected for the 2-, 5-, 10-, 25-, 50-, and 100-year recurrence interval flows.

### **Contents of Plan**

The project engineer will prepare a maintenance plan describing required type and frequency of long-term maintenance of drainage facilities and identification of the party (or parties) responsible for maintenance and operation. Where it is the property owner(s) responsibility to maintain storm drainage facilities, the maintenance plan shall be included by reference in the articles of the home or property owners' association.

Designate the organization or person(s) responsible for O&M of storm drainage facilities. The plan shall include a log of maintenance activity for recording actions that are taken by the responsible party. The plan shall include a provision that the maintenance activity log shall be kept and shall be available for inspection by the City.

### **Vegetation Management Plan**

The effectiveness of many stormwater facilities will depend on the species planted in them and their proper maintenance. The project engineer or qualified landscape professional shall prepare a listing of the proposed native species for the design conditions and their requirements for maintenance. Incorporate specifications and requirements into the maintenance plan.



## **Pollution Source Control**

All maintenance plans shall contain language regarding pollution source control installed on the project site.

### **Appendix E – Covenants, Dedications, Easements**

Include copies of legal instruments needed to guarantee construction of on-site stormwater management BMPs on individual lots, preservation of drainage systems, ongoing maintenance, and access for inspection and maintenance purposes (attach copies).

### **Appendix F – Property Owners' Association Articles of Incorporation**

Attach a copy of the Articles of Incorporation, when applicable and if available.



Page intentionally left blank.



# APPENDIX D - GEOTECHNICAL REPORT GUIDELINES



Page intentionally left blank.

## Geotechnical Report Guidelines

The City may require a geotechnical investigation and report based on the nature of the proposal. For site development for one single-family residence on a site with no steep slopes, erosion hazards, or critical areas, a report previously prepared for that site, may be accepted if:

The report is less than five years old and no significant changes have occurred;

The geotechnical engineer/engineering geologist who signed the report provides a letter stating the report is still applicable to the site and currently proposed project.

The report must be stamped, signed and dated by an engineer licensed by Washington State, who meets the City's criteria for geotechnical engineer. The attached report outline describes the contents for the elements in a geotechnical report; the report submitted to the City must address each element in the outline.

The content under each element will depend on the complexity of the project and site conditions. For example, a single-family residence on a glacial till site without groundwater issues warrants a short, simple report; while a high-rise structure with a deep excavation on an alluvial site warrants a longer, more detailed report. The report should state "Not applicable" for each outline element that does not apply.

The Geotechnical Engineer determines the actual scope of investigation, analysis and reporting necessary to meet the Standard of Practice with respect to the project and its geotechnical requirements.

**GEOTECHNICAL ENGINEER** means a practicing geotechnical/civil engineer licensed as a professional civil engineer by the State of Washington who has at least four years of professional employment as a geotechnical engineer.

**GEOTECHNICAL ENGINEERING** means the application of soil mechanics in the investigation, evaluation, and design of civil works involving the use of earth materials and the inspection or testing of the construction thereof.

**Please use double-sided printing for the report.**

**Number each page.**



## COVER SHEET

The cover sheet has the:

- Project name and address;
- Applicant's name, address, and telephone number;
- Engineering firm's name, address, and contact information;
- Engineer's name and license number;
- Report date and revision dates.

## SUMMARY

The summary presents the major conclusions of the investigation and their bases. This section should be included in all lengthy or complex reports.

## INTRODUCTION

The introduction sets the stage for the entire report and contains the following sections:

### **2.1 Overview**

- Introduce the formal project name, address and parcel numbers.
- Describe slope classification(s) according to SMC 20.80 Subchapter 2 Geologic Hazards.
- Describe briefly the current or previous work used to form the basis for the conclusions and recommendations contained in the report.

### **2.2 Background**

- Describe the project's history when relevant to the reason for the investigation.
- List other reports completed for the site or adjacent sites and note whether any environmental site assessments or other environmental work has been completed.
- Describe the scope of work, including grading, retaining walls, structures, construction materials and utilities. Include dimensions, quantities, proposed finish floor elevations, maximum depth of cut or fill, foundation and floor loads, etc.
- Describe all assumptions that were relied upon to develop the conclusions and recommendations contained in the report.

### **2.3 Purpose And Scope Of Services**

State succinctly the primary purpose for the geotechnical engineering services.

Summarize the scope of geotechnical engineering services that form the basis for the conclusions and recommendations contained in the report.

Indicate any limitations to the scope of geotechnical engineering services provided, particularly if the scope represents a departure from service typically provided on similar projects.

### **2.4 Investigations Summary**

Provide the dates, general nature and extent of the geotechnical investigation. This section should include data research, borings, test pits, geophysics, physical laboratory testing, chemical testing, field instrumentation or testing, etc.

If the investigation was complex, present a complete and detailed explanation and results in the form of an appendix.

### **2.5 Report Overview**

Introduce and describe other sections of the report, directing the reader to critical sections, if appropriate.

Identify and describe all attachments and appendices.

## **SITE CONDITIONS**

Describe all site features relevant to the study and the geotechnical engineering conclusions and recommendations. Terminology should be clear and consistent through the entire Report.

### **3.1 Location And Surface Conditions**

Provide the cross streets, addresses and parcel numbers in order to locate the site.

Describe the site and adjoining properties, including surface elevation, topography and drainage.

Provide current uses of the site and adjacent properties.

Identify all current structures, subsurface utilities, wells, manmade fills and other surface features.

Describe vegetation, topsoil, paving and other surface coverings.

Describe any indications of historic geological processes or hazards on or near the site (e.g., slope instability, landslides, liquefaction, flooding, etc.)

Describe any indications of surface releases or other contamination or potential contamination sources.

Describe any planned changes to the surface conditions described above which will take place after the investigation.

### **3.2 Geological Setting**

Provide an overview of regional geology, local stratigraphy, groundwater occurrence, etc.

### **3.3 Subsurface Soil Conditions**

Describe each soil or geologic unit encountered by their classifications and group units with respect to the properties that are most relevant to the conclusions and recommendations. Give each unit group a unique, clear, common title and consistently refer to this unit by its given title throughout the report.

Provide important results of the laboratory physical property testing and its indications of soil behavior.

Provide design infiltration rate per 2005 Department of Ecology Surface Water Design Manual for Western Washington: Approved method in Volume III Appendix III-D of the Stormwater Manual.

Avoid detailed descriptions of the sequence of units found in individual borings; rather, focus on variations in the units across the site, if appropriate. Refer the reader to the exploration logs for details.

Describe any expected changes in subsurface conditions that may occur with time after the investigation.

### **3.4 Groundwater Conditions**

Describe the nature and occurrence of groundwater.

Provide an opinion on likely seasonal variations in groundwater levels or flows, and the possibility for changes from those encountered at the time of exploration.

Show groundwater levels on soil logs.

### **3.5 Subsurface Contamination**

Describe the nature and extent of soil and/or groundwater contamination as revealed by the explorations. Reference any applicable Environmental Assessments if performed.

Provide important results of the analytical laboratory testing and indications about contamination distribution and concentration.

Indicate limitations of knowledge on the nature and extent of contamination.

Discuss possible changes that may occur in these conditions over time.

## **DISCUSSION AND CONCLUSIONS**

The Discussion and Conclusions should set out major geotechnical issues and alternatives for the project, along with the Geotechnical Engineer's conclusions, in a succinct and clear manner. This section shall clearly describe the logic and reasoning supporting the recommended approach, or alternative approaches. Specific recommendations should be presented in the Recommendations section.

Discussions and Conclusions should:

- Build on information described in the previous sections;

- Describe project features, soils and construction materials using consistent terminology;

- Explain any apparent inconsistencies in the data or investigations;

- Describe clearly any limitations or restrictions to the conclusions and recommendations.

### **4.1 Slope Stability**

Summarize data and analysis used to evaluate slope stability.

Provide an opinion regarding the risk of instability on the site or adjacent properties currently, during construction, and after the project is completed.

Describe how design and construction recommendations will reduce or eliminate the risk of stability.

Discuss any construction or post-construction measures necessary to verify slope stability.

### **4.2 Seismic Considerations**

Provide an opinion on the expected level of ground motion during a major earthquake.

Describe any seismic risks associated with an earthquake such as liquefaction, lateral spreading, landslides, or flooding.

Describe how design and construction recommendations will reduce or eliminate the impact of seismic risks.

### **4.3 Site Work**

Describe proposed site grading and earthwork and provide an opinion on the proper sequence and approach to accomplish the site work.

Describe key issues which will impact earthwork, including short-term slope stability, on-site and import fill materials, groundwater and drainage, rainfall and moisture sensitive soils, and erosion.

Describe how these key issues should be addressed during construction, including dewatering, temporary retaining structures and erosion control.

Include specific recommendations for on-site erosion control based on soil erodability and the presence of groundwater, surface water and slopes.

Include statements regarding the importance of construction monitoring by a geotechnical engineering firm.

### **4.4 Retaining Structures**

Recommend appropriate temporary retaining systems.

Recommend the most appropriate permanent retaining system or systems and describe their expected performance with respect to stability and deflection.

Summarize the data and analysis used to evaluate permanent retaining systems.

Clearly define all limitations on backfill materials, reinforcement, and drainage for reinforced soil slopes and reinforced soil backfill.

Describe the limitations on such systems.

Emphasize any aspects of site work, particularly with respect to the native soil materials, backfill and drainage, which could impact performance of the retaining structures.

Include statements regarding the importance of construction monitoring by a geotechnical engineering firm.

#### **4.5 Rockeries**

Emphasize that rockeries usually protect a slope face from erosion. Indicate which rockeries will protect the slope face by preventing soil erosion and sloughing.

Include the design criteria for rockeries that serve as retaining structures. Indicate which rockeries will function as retaining structures.

Recommend locations for rockeries such that a contractor can reach them for maintenance and repair.

Discuss what type of inspection and testing may be required during rock wall construction.

#### **4.6 Foundation Support**

Summarize the data and analysis used to evaluate foundation systems.

Provide an opinion on the most appropriate foundation system and possible alternatives, along with the expected level of performance with respect to load capacity and settlement.

Emphasize any aspects of site work that could impact the performance of foundations.

Include statements regarding the importance of construction monitoring by a geotechnical engineering firm.

### **RECOMMENDATIONS**

The Recommendations should present all detailed geotechnical engineering recommendations for design and construction in a clear and logical sequence.

For each item covered in the recommendations sections, present the following:

Specific design recommendations along with their limitations, factors of safety, minimum dimensions and effect of expected variations in actual conditions.

Specific construction recommendations including definitions, materials, execution, monitoring testing, or other quality control measures and any other construction requirements to support the design recommendations

Responsibility for seeing that each recommendation is met, such as owner, geotechnical engineer or other design consultant or contractor.

## **5.1 Site Grading And Earthwork**

Provide specific design recommendations for: 1) depth of stripping, 2) soil excavation limits and slopes, 3) depth and lateral limits of over-excavation to remove unsuitable materials, 4) preload fills, 5) location and thickness of particular fill material or compaction requirements, 6) maximum temporary and permanent slopes, 7) permanent surface and subsurface drainage systems, and 8) permanent erosion controls.

Provide specific construction recommendations for: 1) clearing, 2) on-site and/or import fill materials, 3) excavation and compaction equipment, 4) fill material moisture conditioning, placement, and compaction, 5) proof-rolling, in-place density testing and other quality control measures, 6) temporary seepage and drainage control measures, 7) permanent surface of subsurface drainage system installation (as appropriate), and 8) temporary slope protection and erosion control measures.

All design and construction methodologies should be specific and identifiable; generalized or vague statements are NOT acceptable.

## **5.2 Temporary Shoring And Retaining Walls**

Provide specific design recommendations for: 1) active and passive earth pressures, 2) surcharge pressures, 3) bearing capacity, 4) minimum or maximum dimensions and depth of penetration, 5) lateral support, 6) wall or backfill drainage systems, and 7) any other appropriate structured details.

If appropriate, provide specific design recommendations for tie-back anchors including: 1) anchor inclination, 2) no load zones, 3) minimum anchor length, 4) anchor bond zone, 5) anchor adhesions, and 6) corrosion protection.

Provide specific construction recommendations for: 1) installation, 2) on-site and/or import backfill materials, 3) backfill material moisture conditioning, placement, and compaction, 4) in-place density testing or other control measures, and 5) seepage and drainage control.

If appropriate, provide construction recommendations for tie-back anchors including: 1) anchor installation methods, 2) anchor testing, and 3) monitoring.

## **5.3 Rockeries**

Provide recommendations as outlined in the Associated Rockery Contractors (ARC) Standard Rock Wall Construction Guidelines (December 1992).

The geotechnical engineer shall provide direct input to the design of the rockeries and provide construction monitoring and testing as appropriate. Specific design parameters may include: Rock quality, density, frequency of testing, slopes, keyways, surcharges, drainage, rock sizes, face inclination and surface drainage.

#### **5.4 Reinforced Soil Structures**

Geogrid or geotextile fabric may be used to reinforce a fill. If reinforced slopes are used, the geotechnical engineer shall specify, at a minimum, the fill soil materials, vertical spacing of the reinforcement, the specific type of reinforcement and the distance to which it must extend into the fill, the amount of overlap at the reinforcement joints, and the construction sequence. Additional design parameters will be required for each specific site.

#### **5.5 Structure And Foundations**

Provide seismic design recommendations for: 1) Building Code soil type and site coefficients, and 2) any specific recommendations to reduce the risk of damage due to earthquakes.

Spread footing foundations – provide design recommendations for: 1) bearing soils, 2) bearing capacity, 3) minimum footing depths and widths for both interior and exterior footings, 4) lateral load resistance, 5) foundation drainage systems, and 6) frost protection.

Mat foundations – provide design recommendations for: 1) bearing soils, 2) bearing capacity, 3) modulus of subgrade reaction, 4) minimum dimensions, and 5) lateral load resistance.

Pile foundations – provide design recommendations for: 1) type of pile, 2) means of support (end of friction), 3) minimum dimensions and depths, 4) allowable vertical and uplift capacity, 5) allowable lateral loads and deflections, and 6) group effects and minimum spacing.



Spread footing or mat foundations – provide construction recommendations for: 1) foundation subgrade preparation and protection, 2) verification of bearing capacity, and 3) installation of foundation drainage system.

Pile foundations – provide construction recommendations for: 1) pile driving equipment, 2) pile installation, 3) pile load tests or verification piles, and 4) monitoring and testing during pile installation.

## **5.6 Floors**

Slab-on-Grade Floors – provide design recommendations for 1) slab base rock thickness, 2) capillary break, 3) vapor barrier, and 4) floor system drainage.

Supported Wood Floors – provide design recommendations for: 1) vapor barrier and 2) crawl space drainage.

Slab-On-Grade Floors – provide construction recommendations for: 1) subgrade preparation, 2) slab base rock placement and compaction, 3) capillary break and vapor barrier installation, and 4) floor drainage system installation (when appropriate).

## **5.7 Pavements**

Provide design recommendations for 1) pavement design section and 2) pavement drainage.

Provide construction recommendations for 1) pavement subgrade preparation and verification, and 2) pavement base and subbase materials, placement and compaction.

## **5.8 Utilities**

Provide construction recommendations for 1) utility excavation, 2) bedding material placement and 3) backfill material, placement and compaction.

## **5.9 Drainage**

Recommend provisions for subsurface drainage at walls, floors and footings.

Evaluate permanent and temporary surface and subsurface drainage for both walls and floors if applicable. Provide approximate flow rates in gallons per minute and pipe sizes if required by design.

Provide design and recommendation for infiltration facilities, including setbacks from steep slopes per the adopted Stormwater Manual.

#### **5.10 Hazards**

Present additional information if natural or man-made hazards exist on the property. The City's Critical Areas maps identify hazards such as wetlands, streams and flood hazards, erosion, and steep slopes. Recommendations should be general, and further studies may be required.

### **FIGURES AND ILLUSTRATIONS**

#### **6.1 Vicinity Map**

Include a Vicinity or Location Map that presents adequate street and/or other physical references to allow clear identification of the project location. This map may be an individual figure or may be included on the Site Plan.

#### **6.2 Site Plan**

Show the project boundaries, property lines, existing features and the proposed development and structures. A north arrow and scale should be included along with all subsurface exploration locations. The accuracy of exploration locations should be indicated on the Site Plan or in the report.

#### **6.3 Exploration Logs**

Include logs of all explorations describing soil units encountered, soil classification, density or stiffness, moisture conditions, groundwater levels, stratigraphic sequence, common geologic unit name, and other descriptive information.

#### **6.4 Laboratory Test Data**

Include figures or tables of laboratory test results if presentation of all the data, in the text, would require more than a simple paragraph to supplement the data provided in the exploration logs.

#### **6.5 Cross Sections**

Include cross sections to visually present all but the simplest subsurface conditions.

## 6.6 Standard Plans

Include figures, graphs and other visual aids to clearly present detailed recommendations.

Provide design details (stamped by a professional engineer licensed in Washington State) on drawings such as: rockeries, reinforced earth, interceptor trenches, wall and footing drains, utility backfill and other details used for a particular design.

### PROJECT ENGINEER'S CERTIFICATION

The report shall contain a page with the project engineer's seal, signature, and date signed, with the following statement:

"I hereby state that this geotechnical report for \_\_\_\_\_  
(name of project) has been prepared by me or under my supervision and meets the standard of care and expertise which is usual and customary in this community for professional engineers. I understand that the City of Shoreline does not and will not assume liability for the sufficiency, suitability, or performance of facilities prepared based on this report."



Page intentionally left blank.



# APPENDIX E - TRANSPORTATION IMPACT ANALYSIS REPORT GUIDELINES





Page intentionally left blank.

## Transportation Impact Analysis Guidelines

### GENERAL REQUIREMENTS

- Provide two (2) copies, printed double-sided and one (1) electronic copy in PDF format.
- The estimate of vehicle trips shall be conducted in accordance with the most recent version of the Trip Generation Manual, published by the Institute of Transportation Engineers.
- Traffic Level of Service (LOS) analysis shall be conducted using methodology consistent with the most recent version of the Highway Capacity Manual.
- The year of completion of the project's final phase shall be used as the horizon year.
- Must be prepared by a Licensed Engineer with a background in traffic analysis.

### TRANSPORTATION IMPACT ANALYSIS OUTLINE

Regional/ Standard	Section	Content to include
<b>Standard</b>	Cover Page	<ul style="list-style-type: none"> <li>• Applicant</li> <li>• Project title</li> <li>• Project address</li> <li>• Preparer's contact information, signature, and professional engineer stamp.</li> </ul>
<b>Standard</b>	Introduction	<ul style="list-style-type: none"> <li>• Complete project description                             <ul style="list-style-type: none"> <li>○ Current and proposed zoning, Comprehensive Plan Designation;</li> <li>○ Proposed land use(s);</li> <li>○ Size of development such as number and type of housing units and/or gross floor area;</li> <li>○ Phasing plan for complex projects.</li> </ul> </li> <li>• Project location and study area boundary.</li> <li>• Executive summary of findings and mitigations, if applicable.</li> </ul>
<b>Standard</b>	Site Evaluation	<ul style="list-style-type: none"> <li>• Sight distance evaluation for all access points; include plan showing required sight triangles and any obstructions located within.</li> <li>• Access design and vehicle queueing.</li> <li>• Pedestrian and bicycle access from the public Right-of-Way and adjacent land uses to all principal entrances.</li> <li>•</li> </ul>
<b>Standard</b>	Traffic Impacts	<p><b>Existing conditions</b></p> <ul style="list-style-type: none"> <li>• Description of critical intersections and roadways;</li> <li>• Identification of peak usage period(s)</li> </ul>

- Identify City capital projects and planned transportation improvements located in the study area;
- Identify transportation improvements in the study area planned by other private developers or by governments or agencies other than the City of Shoreline;
- Identify existing roadway volumes as well as entering, and exiting volumes from the site during the PM and peak usage period(s). Existing trips must be measured assuming full occupancy of the existing use on site. If the site and/or existing buildings have been vacant for more than one year, the trips associated with the site and/or use will not be utilized to determine net new trips resulting from the proposed development.
- Existing Level of Service (LOS) at intersections and applicable roadway segments in the study area.
- Description of other travel modes and facilities serving the project location within ¼ mile of the project site. (If Regional analysis is required, this element may be covered in other sections)
- If applicable, a gap analysis, transportation network model analysis may be required at the discretion of the City Traffic Engineer

**Safety**

- Document collisions within the study area boundary for the most recent 3 years of collision data available.

**Future conditions**

- Trip generation
- Background traffic growth
- Pipeline project growth
- Trip distribution
  - Determined by existing characteristics if proposal is consistent with existing land uses in the study area;
  - Origin/destination studies;
  - Trip distribution models; or
  - Market studies.

**Regional** Pedestrian Facility Impacts

**Existing conditions**

- Within ¼ mile of the project, specifically describe the characteristics of the pedestrian facilities on all arterial streets. For local streets, summarize pedestrian facilities. Note any important characteristics of specific local streets;
- Summary of pedestrian counts at study intersections and on trails, if within the ¼ mile study area;
- Identify key pedestrian trip generators within ½ mile of the project.

### Accessibility

- In accordance with 2011 PROWAG, inventory barriers to accessibility along all arterials within ¼ mile of the project. Barriers include but are not limited to:
  - **Non-accessible or missing curb ramps;**
  - **Obstructions within the sidewalk or pedestrian pathway;**
  - **Vertical discontinuities;**
  - **Non-standard cross slopes and/or running slopes;**
  - **Sub-standard pedestrian pushbuttons at signalized intersections.**

### Safety

Within ¼ mile of the project:

- **Inventory all locations with pedestrian related collisions within the most recent 5 years of collision data available.**
- **Inventory all locations along arterials where there is no buffer between the pedestrian space and traffic.**
- **For intersections greater than 250 feet from a signalized crossing or grade separated crossing, identify all legal crossings where pedestrians must cross more than one lane in each direction and/or locations where the posted speed limit is greater than 25 mph.**
- **Identify all school crossings.**

### Pedestrian Network Gaps

Describe all bike facilities within ¼ mile of the project that are identified within the Transportation Master Plan pedestrian element, and which have not yet been constructed and/or planned improvements will not be constructed by the horizon year.

### Regional

Bicycle Facility  
Impacts

### Existing Conditions

- Describe all bicycle facilities within ¼ mile of the project that are present on arterials.

### Safety

Within ½ mile of the project:

- Inventory all locations with bicycle related collisions within the most recent 5 years of available collision data.
- Inventory all locations along arterials where there is no buffer between the bicycle facility and traffic.
- Identify any locations with significant pavement irregularities.

		<p><b>Bicycle Network Gaps</b></p> <p>Describe all bike facilities within ¼ mile of the project that are identified within the Transportation Master Plan bicycle element and which have not yet been constructed and/or planned improvements will not be constructed by the horizon year.</p>
<b>Regional</b>	Transit Impacts	<p><b>Existing Conditions</b></p> <ul style="list-style-type: none"> <li>• Inventory all transit routes and stops within ¼ mile of the project.</li> <li>• Inventory all Park &amp; Ride locations and usage within ½ mile of the project.</li> <li>• For routes within ¼ mile of the station and referring to King County Metro’s most recent Service Guidelines Report, identify routes that: <ul style="list-style-type: none"> <li>○ Serve corridors below target service levels;</li> <li>○ Need investments to reduce crowding, and/or;</li> <li>○ Need investments to improve schedule reliability.</li> </ul> </li> </ul> <p><b>Accessibility</b></p> <ul style="list-style-type: none"> <li>• For all transit stops within ¼ mile of the project, identify barriers to accessibility including but not limited to: <ul style="list-style-type: none"> <li>○ Bus stop front door landing.</li> <li>○ Access to and from bus shelter where applicable.</li> </ul> </li> </ul> <p><b>Future Conditions</b></p> <p>Considering results of traffic modeling, report on added delay to transit routes within the study area.</p>
<b>Regional</b>	Parking Impacts	<p><b>Existing Conditions</b></p> <p>Within ¼ mile of the project, inventory all available on street parking and parking restrictions.</p> <p><b>Parking Demand</b></p> <ul style="list-style-type: none"> <li>• Forecast anticipated parking demand for horizon year build out.</li> <li>• Compare project’s proposed parking provisions with demand and with Shoreline Code.</li> </ul>
<b>Regional</b>	Neighborhood Impacts	<p><b>Existing Conditions</b></p> <ul style="list-style-type: none"> <li>• Identify neighborhoods within ¼ mile of the project with active Neighborhood Traffic Safety Projects (NTSP). (To be supplied by City).</li> <li>• Identify which elements of the neighborhood’s Traffic Action Plan have not yet been completed.</li> </ul>

- Identify neighborhood streets where project traffic is anticipated. Document speeds and traffic volumes for these streets.

**Neighborhood Outreach and Action Plan**

A public meeting shall be arranged for residents within ¼ mile of the project to explain the project, gather feedback, and develop an action plan for project impacts. An alternative outreach strategy may submitted in writing with adequate documentation for review by the City Traffic Engineer. An Action Plan shall be consistent with the City of Shoreline’s NTSP criteria available on the Traffic Services webpage.

<b>Standard</b>	Conclusions	Describe project impacts and proposed plans and/or mitigations. In addition, all projects should strive to incorporate Transportation Demand Management (TDM) strategies – describe how this will be achieved.
-----------------	-------------	--

Page intentionally left blank.





# APPENDIX F - STREET MATRIX

Page intentionally left blank.

## Master Street Plan

The 2011 Master Street Plan identifies specific roadway cross-sections for all Arterial Streets and Local Primary Streets in the City of Shoreline. It is intended to guide the development of streets throughout the City. The planned cross-sections for these streets establish the location of future curbs so that streets can be constructed in the proper location.

The Master Street Plan also identifies a general cross-section for Local Secondary Streets which provide for travel in each direction, on-street parking and sidewalks on each side of the street. Due to the large number of Local Secondary Streets in the City, a determination of the appropriate cross-section for a given Local Secondary Street will be made at the time modifications to the street are funded or redevelopment occurs. Additionally, because the needs and conditions of the Local Secondary Streets vary greatly throughout the City, the design criteria must be flexible.

The design criteria for Local Secondary Streets may vary in the following ways:

### Curb-to-curb widths

- Ditch on one side in the place of amenity zones

- Sidewalk on one side only

- Parking on one side only

- Wider amenity zone

- Meandering sidewalk

- Pervious walkways

- Curb on one side only

- Concrete edge – at grade sidewalk

Many of these features will also be included as part of Green Street projects in the City.

In accordance with the adopted policies and implementation strategies associated with the Master Street Plan, the following principles accompany its implementation:

- Frontage improvements shall support the adjacent land uses and fit the character of the areas in which they are located. Five feet is the standard sidewalk width adjacent to single-family residential land uses, and eight feet is the standard sidewalk width adjacent to all land uses

other than single-family residential. Increased width may be required if determined by a traffic study.

The amenity zone should be developed in a manner that is appropriate and complimentary to the adjacent land uses and use of the street. The minimum width for amenity zones is five feet. Amenity zones should generally be landscaped and, where possible, utilized for stormwater management purposes. Amenity zones adjacent to roadways that do not have off-street parking shall be landscaped as much as possible. In areas where a wide pedestrian walking surface is desired, such as commercial areas, the amenity zone may be a hard surface treatment with trees in pits. Amenity zones that are adjacent to on-street parking areas should be landscaped as much as possible but may include limited hard surface areas for drivers or passengers exiting vehicles.

The identified cross-sections should still allow for flexibility to account for site specific, unique or unforeseen circumstances (such as presence of bus stops), topography, sensitive areas, and presence of significant vegetation (large trees).

The maximum right-of-way needs for street classifications are as follows:

- Principal Arterial – 120 feet
- Minor Arterial – 95 feet
- Collector Arterial – 80 feet
- Local Primary Street – 66 feet
- Local Secondary Street – 90 feet

FUNCTIONAL CLASSIFICATION	STREET NAME	FROM	TO	TOTAL EXISTING RIGHT-OF-WAY	EXISTING CURB TO CURB WIDTH	CROSS-SECTION DIRECTION	BEHIND SIDEWALK	SIDEWALK	AMENITY ZONE	CURB	PARKING	BICYCLE LANE	TRAVEL LANE	CENTER TURN LANE	TRAVEL LANE	BICYCLE LANE	PARKING	CURB	AMENITY ZONE	SIDEWALK	BEHIND SIDEWALK	REQUIRED RIGHT-OF-WAY	PLANNED CURB TO CURB WIDTH	NOTES
ARTERIAL STREETS AND LOCAL PRIMARY STREETS																								
Collector Arterial	1st Ave NE	N 145th St	N 149th St	60	26-37	W-E	1	5	5.5	0.5	8	0	10	0	10	0	8	0.5	5.5	8	1	63	36	East side properties must dedicate 3 feet in conjunction with redevelopment.
Collector Arterial	1st Ave NE	N 149th St	NE 155th St	82-123	30-36	W-E	1	8	5.5	0.5	8	0	10	0	10	0	8	0.5	5.5	5	1	63-66	36	Wider amenity zones where there is extra right-of-way.
Collector Arterial	1st Ave NE	NE 185th St	Approx. 175 feet south of NE 190th St	60	35	W-E	1	5	5.5	0.5	0	5	10	0	10	5	8	0.5	5.5	8	1	65	38	Property on the east will dedicate 5 feet at the time of redevelopment
Collector Arterial	1st Ave NE	Approx. 175 feet south of NE 190th St	Approx. 130 feet north of NE 192nd St	60	47-60	W-E	1	5	5.5	0.5	0	5	10	0	10	5	18				60	48	Utilize the eastern 18' for back in angle parking and sidewalk. A portion of the sidewalk is on City property or will be dedicated.	
Collector Arterial	1st Ave NE	Approx. 130 feet north of NE 192nd St	NE 195th St	60	21-29	W-E	1	5	5	0.5	0	5	10.5	0	10.5	5	8	0.5	0	8	1	60	39	Property at the SE corner of 1st and 193rd was required to install parking as part of Conditional Use permit.
Collector Arterial	1st Ave NE	NE 195th St	N 205th St	60	29	W-E	1	8	5	0.5	8	0	10.5	0	10.5	0	0	16.5				60	29	Utilize the eastern 16.5 ' for natural stormwater treatment
Collector Arterial	3rd Ave NW	NW 171st St	NW 175th St	60-90	22-34	W-E	1	8	5	0.5	8	0	10	0	10	0	8	0.5	5	5	1	62	36	On-street parking to be provided where feasible
Local Primary Street	3rd Ave NW	NW 180th St	NW Richmond Beach Rd	60	24-30	W-E	1	5	8.5	0.5	0	0	15	0	15	0	0	0.5	8.5	5	1	60	30	
Collector Arterial	3rd Ave NW	NW Richmond Beach Rd	NW 205th St	60	28-36	W-E	1	5	5.5	0.5	0	0	14	0	14	0	8	0.5	5.5	5	1	60	36	
Minor Arterial	5th Ave NE	NE 145th St	NE 148th St	60	43	To be determined in conjunction with 145th Street Corridor study																		

FUNCTIONAL CLASSIFICATION	STREET NAME	FROM	TO	TOTAL EXISTING RIGHT-OF-WAY	EXISTING CURB TO CURB WIDTH	CROSS-SECTION DIRECTION	BEHIND SIDEWALK	SIDEWALK	AMENITY ZONE	CURB	PARKING	BICYCLE LANE	TRAVEL LANE	CENTER TURN LANE	TRAVEL LANE	BICYCLE LANE	PARKING	CURB	AMENITY ZONE	SIDEWALK	BEHIND SIDEWALK	REQUIRED RIGHT-OF-WAY	PLANNED CURB TO CURB WIDTH	NOTES
Minor Arterial	5th Ave NE	NE 148th St	NE 163rd St	60	43	W-E	0.5	5	5	0.5	12	10	0	10	12	0.5	5	5	0.5	66	44	Combined bicycle and parking lane. Need to acquire 3 feet from each side.		
Minor Arterial	5th Ave NE	NE 163rd St	Approx. 300 feet north of NE 165th St	60-90	43-50	W-E	0.5	8	5	0.5	12	10	12	10	12	0.5	5	8	0.5	84	56	Combined bicycle and parking lane. Need to acquire 12 feet from each side. Construct wider amenity zone or sidewalk where ROW exceeds 84 feet.		
Minor Arterial	5th Ave NE	Approx. 300 feet north of NE 165th St	NE 174th St	60-72	43	W-E	0.5	5	5	0.5	12	10	0	10	12	0.5	5	5	0.5	66	44	Combined bicycle and parking lane. Need to acquire 3 feet from each side.		
Minor Arterial	5th Ave NE	NE 174th St	NE Serpentine PI	60	24-42	W-E	1	8	5	0.5	0	5	11	12	11	5	0	0.5	5	5	1	70	44	Need to acquire 5 feet from each side.
Minor Arterial	5th Ave NE	NE Serpentine PI	NE 185th St	52-124	22-36	W-E	0.5	5	5	0.5	12	10	0	10	12	0.5	5	5	0.5	66	44	Combined bicycle and parking lane. Need to acquire 3 feet from each side.		
Collector Arterial	5th Ave NE	NE 185th St	NE 195th St	30-116	16-28	W-E	0.5	8	5	0.5	0	5	10	0	10	5	8	0.5	5	8	0.5	66	38	
Collector Arterial	5th Ave NE	NE 195th St	NE 205th St	60	25	W-E	17				0	0	11	0	11	0	21				60	43	Utilize the western 17 feet for natural stormwater treatment; use the eastern 21 ' for a combination of parking, amenity zone, natural stormwater treatment and sidewalk, based upon topography and soils.	
Collector Arterial	6th Ave NW	NW 175th St	NW 180th St	60	24	W-E	1	5	5.5	0.5	8	0	11.5	0	11.5	5	0	0.5	5.5	5	1	60	36	This cross-section allows for an uphill climbing lane and downhill shared/signed lane
Collector Arterial	8th Ave NW	NW 180th St	NW 185th St	60	20	W-E	0.5	5	5	0.5	0	5	10	0	10	5	8	0.5	5	5	0.5	60	38	

FUNCTIONAL CLASSIFICATION	STREET NAME	FROM	TO	TOTAL EXISTING RIGHT-OF-WAY	EXISTING CURB TO CURB WIDTH	CROSS-SECTION DIRECTION	BEHIND SIDEWALK	SIDEWALK	AMENITY ZONE	CURB	PARKING	BICYCLE LANE	TRAVEL LANE	CENTER TURN LANE	TRAVEL LANE	BICYCLE LANE	PARKING	CURB	AMENITY ZONE	SIDEWALK	BEHIND SIDEWALK	REQUIRED RIGHT-OF-WAY	PLANNED CURB TO CURB WIDTH	NOTES
Collector Arterial	8th Ave NW	NW 185th St	NW Richmond Beach Rd	60	29-35	W-E	1	5	5	0.5	0	5	10	0	10	5	8	0.5	5	8	1	64	38	Property on the east side will dedicated 8' at the time of redevelopment
Minor Arterial	8th Ave NW	NW Richmond Beach Rd	Approx. 80 feet north of NW 190th St	60	22	W-E	0.5	5	5	0.5	12	10	12	0	11	5	0	0.5	5	8	0.5	75	50	For this cross-section, no parking on either side of the street and no bicycle lane on the west side. Figures include a right turn lane, SB through lane, left turn lane and NB through lane.
Minor Arterial	8th Ave NW	Approx. 80 feet north of NW 190th St	NW 205th St	60-75	20-32	W-E	0.5	5	5	0.5	0	5	10	0	10	5	8	0.5	5	5	0.5	60	38	On-street parking allowed where ROW is wider
Local Primary Street	10th Ave NE	NE 155th St	NE 175th St	70-80	25-36	W-E	1	5	7.5	0.5	0	0	16	0	16	0	0	0.5	7.5	5	1	60	32	
Collector Arterial	10th Ave NE	NE 175th St	NE 185th St	70-80	32	W-E	10.5-20.5	5	5	0.5	8	0	11	0	11	0	8	0.5	5	5	0.5	70-80	38	Utilize the space behind the sidewalk for natural stormwater management
Collector Arterial	10th Ave NE	NE 185th St	NE 190th St	60-160	32	W-E	0.5	5	5	0.5	8	0	11	0	11	0	8	0.5	5	5	0.5	60	38	Would consider vacating and squaring the intersection at 185th and 10th; sharrows in both travel lanes

FUNCTIONAL CLASSIFICATION	STREET NAME	FROM	TO	TOTAL EXISTING RIGHT-OF-WAY	EXISTING CURB TO CURB WIDTH	CROSS-SECTION DIRECTION	BEHIND SIDEWALK	SIDEWALK	AMENITY ZONE	CURB	PARKING	BICYCLE LANE	TRAVEL LANE	CENTER TURN LANE	TRAVEL LANE	BICYCLE LANE	PARKING	CURB	AMENITY ZONE	SIDEWALK	BEHIND SIDEWALK	REQUIRED RIGHT-OF-WAY	PLANNED CURB TO CURB WIDTH	NOTES
Collector Arterial	10th Ave NW	NW Innis Arden Way	NW 175th St	60	20	S-N	0	0	0	0	8	0	12	0	12	0	0	0.5	5	5	17.5	60	32	No sidewalk on the south side. On-street parking on the south side accommodated where possible. Cross-section across the bridge is two 12 foot travel lanes and an 8 foot sidewalk on the north side with no amenity zone.
Local Primary Street	10th Ave NW	NW 175th St	NW 180th St	50-60	20	W-E	1	5	5.5	0.5	8	0	10	0	10	0	8	0.5	5.5	5	1	60	36	
Collector Arterial	14th Ave NW	Springdale Ct NW	NW 175th St	60	20	W-E	1	5	5.5	0.5	8	0	10	0	10	0	8	0.5	5.5	5	1	60	36	
Principal Arterial	15th Ave NE	NE 145th St	NE 150th St	60-77	52-55	W-E	1	8	5.5	0.5	0	0	22	12	22	0	0	0.5	5.5	8	1	86	56	Two travel lanes in each direction
Principal Arterial	15th Ave NE	NE 150th St	NE 152nd St	60-73	44-54	W-E	1	8	5.5	0.5	0	0	24	12	24	0	0	0.5	5.5	8	1	90	60	Two travel lanes in each direction
Principal Arterial	15th Ave NE	NE 152nd St	NE 155th St	60-65	44-50	W-E	1	8	5.5	0.5	0	5	11	12	11	5	0	0.5	5.5	8	1	74	44	
Principal Arterial	15th Ave NE	NE 155th St	NE 165th St	60-65	42-50	W-E	1	5	5	0.5	0	5	11	12	11	5	0	0.5	5	8	1	70	44	
Principal Arterial	15th Ave NE	NE 165th St	NE 169th St	60	44	W-E	1	5	5.5	0.5	0	5	11	12	11	5	0	0.5	5.5	5	1	68	44	
Principal Arterial	15th Ave NE	NE 169th St	NE 172nd St	60	44	W-E	1	5	5	0.5	0	5	11	12	11	5	0	0.5	5	8	1	70	44	
Principal Arterial	15th Ave NE	NE 172nd St	NE 175th St	60-70	52-44	W-E	0	5	2	0.5	0	5	11	12	11	5	0	0.5	2	5	0	59	44	



FUNCTIONAL CLASSIFICATION	STREET NAME	FROM	TO	TOTAL EXISTING RIGHT-OF-WAY	EXISTING CURB TO CURB WIDTH	CROSS-SECTION DIRECTION	BEHIND SIDEWALK	SIDEWALK	AMENITY ZONE	CURB	PARKING	BICYCLE LANE	TRAVEL LANE	CENTER TURN LANE	TRAVEL LANE	BICYCLE LANE	PARKING	CURB	AMENITY ZONE	SIDEWALK	BEHIND SIDEWALK	REQUIRED RIGHT-OF-WAY	PLANNED CURB TO CURB WIDTH	NOTES
Principal Arterial	15th Ave NE	NE 175th St	NE 180th St	70-80	40-54	W-E	0	6	4	0.5	7	0	22	0	22	0	7	0.5	4	6	0	79	58	Sidewalk located on private property in some locations. Two travel lanes in each direction
Principal Arterial	15th Ave NE	NE 180th St	24th Ave NE	42-95	40-44	W-E	1	8	5.5	0.5	0	5	11	12	11	5	0	0.5	5.5	8	1	74	44	Narrower sidewalks and less dedication required in front of SF properties
Principal Arterial	15th Ave NE	24th Ave NE	NE 190th St	57-80	42-44	W-E	1	5	5.5	0.5	0	5	11	12	11	5	0	0.5	5.5	5	1	68	44	
Principal Arterial	15th Ave NE	NE 190th St	Ballinger Way NE	60-90	40-60	W-E	1	8	5.5	0.5	0	5	11	12	11	5	0	0.5	5.5	8	1	74	44	Narrower sidewalks and less dedication required in front of SF properties
Collector Arterial	15th Ave NW	NW 167th St	NW 175th St	60	20	W-E	1	5	5.5	0.5	0	0	13	0	13	0	0	0.5	5.5	5	1	50	26	
Collector Arterial	15th Ave NW	NW 188th St	Approx. 50 feet north of NW 191st St	60	20	W-E	1	5	5.5	0.5	8	0	10	0	10	0	8	0.5	5.5	5	1	60	36	All dedication would come from the west side, as the ROW is offset 10'
Collector Arterial	15th Ave NW	Approx. 50 feet north of NW 191st St	NW Richmond Beach Rd	50-60	20-37	W-E	1	8	5	0.5	8	0	10	0	10	0	8	0.5	5	8	1	65	36	MF properties will dedicate 7.5 feet on each side.
Collector Arterial	15th Ave NW	NW Richmond Beach Rd	NW 205th St	40-60	24-100	W-E	1	5	5.5	0.5	8	0	10	0	10	0	8	0.5	5.5	5	1	60	36	
Minor Arterial	19th Ave NE	Forest Park Dr NE	NE 199th St	60	36	W-E	1	5	5.5	0.5	8	0	10	0	10	0	8	0.5	5.5	5	1	60	36	
Minor Arterial	19th Ave NE	NE 199th St	NE 205th St	60-70	36-40	W-E	0.5	8	5	0.5	8	0	10	0	10	0	8	0.5	5	8	0.5	64	36	
Local Primary Street	20th Ave NW	Saltwater Park Entrance	NW 195th	60	18	W-E	0.5	8	0	0.5	8	0	11	0	11	0	0	0.5	5	5	0.5	50	30	

FUNCTIONAL CLASSIFICATION	STREET NAME	FROM	TO	TOTAL EXISTING RIGHT-OF-WAY	EXISTING CURB TO CURB WIDTH	CROSS-SECTION DIRECTION	BEHIND SIDEWALK	SIDEWALK	AMENITY ZONE	CURB	PARKING	BICYCLE LANE	TRAVEL LANE	CENTER TURN LANE	TRAVEL LANE	BICYCLE LANE	PARKING	CURB	AMENITY ZONE	SIDEWALK	BEHIND SIDEWALK	REQUIRED RIGHT-OF-WAY	PLANNED CURB TO CURB WIDTH	NOTES
Collector Arterial	20th Ave NW	NW 195th St	NW 205th St	40-50	22-30	W-E	1	5	5.5	0.5	8	0	10	0	10	0	8	0.5	5.5	5	1	60	36	
Collector Arterial	22nd Ave NE	NE 171st St	NE 172nd St	60	24-34	W-E	0.5	5	5	0.5	8	0	11	0	11	0	8	0.5	5	5	0.5	60	38	
Minor Arterial	24th Ave NE	24th PI NE	15th Ave NE	60-110	26-37	S-N	0.5	5	5	0.5	8	5	10	0	10	5	0	0.5	5	5	0.5	60	38	
Collector Arterial	25th Ave NE	NE 145th St	NE 150th St	30-60	28-38	W-E	0.5	5	5	0.5	0	5	10	0	10	5	8	0.5	5	5	0.5	60	38	
Collector Arterial	25th Ave NE	NE 150th St	NE 153rd St	60	31	W-E	3	5	3	0.5	0	5	10	0	10	5	7.5	0.5	5	5	0.5	60	37.5	
Collector Arterial	25th Ave NE	NE 153rd St	NE 165th St	30	30 - 31	W-E	0	8	5	0.5	0	5	10	0	10	5	7.5	0.5	5	5	0.5	60	37.5	
Collector Arterial	25th Ave NE	NE 165th St	NE 168th St	60	35-43	W-E	0.5	5	5	0.5	0	5	10	0	10	5	8	0.5	5	5	0.5	60	38	
Collector Arterial	25th Ave NE	NE 168th St	NE 175th St	60	24-30	W-E	0.5	5	5	0.5	0	5	10	0	10	5	8	0.5	5	5	0.5	60	38	
Collector Arterial	25th Ave NE	NE 175th St	NE 177th St	60	23-26	W-E									38							60	38	
Collector Arterial	25th Ave NE	NE 177th St	NE 178th St	60-110	27	W-E	0	5	8	0	0	0	12	0	12	0	0	0	8	5	0	45	24	Amenity zone will be the shoulder. Preferred width on the east. No sidewalk is planned for the west side of the street due to topography and surface water management needs.
Collector Arterial	25th Ave NE	NE 178th St	NE 185th St	55-67	26	SW-NE	1	5	5.5	0.5	8	0	10	0	10	0	8	0.5	5.5	5	1	60	36	

FUNCTIONAL CLASSIFICATION	STREET NAME	FROM	TO	TOTAL EXISTING RIGHT-OF-WAY	EXISTING CURB TO CURB WIDTH	CROSS-SECTION DIRECTION	BEHIND SIDEWALK	SIDEWALK	AMENITY ZONE	CURB	PARKING	BICYCLE LANE	TRAVEL LANE	CENTER TURN LANE	TRAVEL LANE	BICYCLE LANE	PARKING	CURB	AMENITY ZONE	SIDEWALK	BEHIND SIDEWALK	REQUIRED RIGHT-OF-WAY	PLANNED CURB TO CURB WIDTH	NOTES
Local Primary Street	25th Ave NE	NE 195th St	NE 200th St	60	23-25	W-E	0.5	8	5	0.5	0	0	13	0	11	0	8	0.5	5	8	0.5	60	32	Sharrows in travel lanes
Local Primary Street	25th Ave NE	NE 200th St	NE 205th St	60	23	W-E	0.5	5	5	0.5	8	0	11	0	11	0	8	0.5	5	5	0.5	60	38	Sharrows in travel lanes
Local Primary Street	Ashworth Ave N	N 155th St	N 175th St	60	24-28	W-E	1	5	7.5	0.5	0	0	16	0	16	0	0	0.5	7.5	5	1	60	32	
Local Primary Street	Ashworth Ave N	N 175th St	N 185th St	60	23-28	W-E	1	5	5.5	0.5	8	0	10	0	10	0	8	0.5	5.5	5	1	60	36	
Collector Arterial	Ashworth Ave N	N 185th St	N 192nd St	60	24-30	W-E	0.5	5	5	0.5	8	0	11	0	10	4	9			6	1	60	42	Shoulder is 4 feet wide.
Collector Arterial	Ashworth Ave N	N 192nd St	N 195th St	60	20-29	W-E	1	5	5.5	0.5	8	0	10	0	10	0	8	0.5	5	8	1	62.5	36	Development on the east must dedicated 2.5 feet
Collector Arterial	Ashworth Ave N	N 195th St	N 199th St	60	23	W-E	1	5	5.5	0.5	8	0	10	0	10	0	8	0.5	5.5	5	1	60	36	
Collector Arterial	Ashworth Ave N	N 199th St	N 200th St	60	27	W-E	1	5	5.5	0.5	8	0	10	0	10	0	8	0.5	5	8	1	62.5	36	Development on the east must dedicated 2.5 feet if developed as something other than single-family; the cross-section on the west will match the park if the City acquires additional property and extends the existing improvements.
Principal Arterial	Ballinger Way NE	15th Ave NE	Approx. 600 feet south east of 19th Ave NE	90-120	62-86	W-E	1	8	21.5	0.5	0	0	24	12	24	0	0	0.5	19.5	8	1	120	60	2 travel lanes in each direction. The amenity zone width to be adjusted for BAT lanes.

FUNCTIONAL CLASSIFICATION	STREET NAME	FROM	TO	TOTAL EXISTING RIGHT-OF-WAY	EXISTING CURB TO CURB WIDTH	CROSS-SECTION DIRECTION	BEHIND SIDEWALK	SIDEWALK	AMENITY ZONE	CURB	PARKING	BICYCLE LANE	TRAVEL LANE	CENTER TURN LANE	TRAVEL LANE	BICYCLE LANE	PARKING	CURB	AMENITY ZONE	SIDEWALK	BEHIND SIDEWALK	REQUIRED RIGHT-OF-WAY	PLANNED CURB TO CURB WIDTH	NOTES
Principal Arterial	Ballinger Way NE	Approx. 600 feet south east of 19th Ave NE	22nd Ave NE	100	48-56	W-E	1	8	15.5	0.5	0	0	14	12	14	0	0	0.5	15.5	8	1	90	40	The amenity zone width to be adjusted for BAT lanes.
Principal Arterial	Ballinger Way NE	22nd Ave NE	25th Ave NE	80-90	42-58	W-E	1	8	5.5	0.5	0	0	14	0	14	0	0	0.5	15.5	8	1	68	28	All widening to occur on the east/northeast, the amenity zone width to be adjusted for topography or for BAT lanes.
Collector Arterial	Carlyle Hall Rd N	NW 171st St	Dayton Ave N	60-90	22-34	W-E	1	8	5	0.5	8	0	10	0	10	0	8	0.5	5	5	1	62	36	On-street parking to be provided where feasible
Collector Arterial	Carlyle Hall Road N	Evanston Place N	Dayton Ave N	60+	30+	N-S	0.5	5	5	0.5	0	5	10	0	10	5	8	0.5	5	5	0.5	60	38	
Minor Arterial	Dayton Ave N	Westminster Way N	N 160th St	90-111	38-54	W-E	0.5	5	5	0.5	12		10	0	10	12		0.5	5	5	0.5	66	44	
Minor Arterial	Dayton Ave N	N 160th St	Carlyle Hall Road N	95-108	30-38	W-E	0.5	5	5	0.5	8	5	10	0	10	5	0	0.5	5	5	0.5	60	38	
Minor Arterial	Dayton Ave N	Carlyle Hall Road N	N 172nd St	60	22-30	W-E	0.5	5	5	0.5	8	0	11	0	11	0	8	0.5	5	5	0.5	60	38	
Minor Arterial	Dayton Ave N	N 172nd St	St. Luke Pl N	60	22-30	W-E	1	6	4	0.5	0	0	12	0	12	0	8	0.5	0	8	1	52	32	
Minor Arterial	Dayton Ave N	St. Luke Pl N	N Richmond Beach RD	60-75	22-28	W-E	0.5	5	5	0.5	8	0	11	0	11	0	8	0.5	5	5	0.5	60	38	
Collector Arterial	Fremont Ave N	N 165th St	N 205th St	60-72	28-39	W-E	0.5	5	5	0.5	8	5	10	0	10	5	8	0.5	5	5	0.5	68	46	
Collector Arterial	Forest Park Dr	15th Ave NE	NE 196th St	60	21-23	SW-NE	1	5	5.5	0.5	8	0	10	0	10	0	8	0.5	5.5	5	1	60	36	
Principal Arterial	Greenwood Ave N	N 145th St	Westminster Way N	80+	62+	To be determined in conjunction with 145th Street Corridor study																		

FUNCTIONAL CLASSIFICATION	STREET NAME	FROM	TO	TOTAL EXISTING RIGHT-OF-WAY	EXISTING CURB TO CURB WIDTH	CROSS-SECTION DIRECTION	BEHIND SIDEWALK	SIDEWALK	AMENITY ZONE	CURB	PARKING	BICYCLE LANE	TRAVEL LANE	CENTER TURN LANE	TRAVEL LANE	BICYCLE LANE	PARKING	CURB	AMENITY ZONE	SIDEWALK	BEHIND SIDEWALK	REQUIRED RIGHT-OF-WAY	PLANNED CURB TO CURB WIDTH	NOTES
Collector Arterial	Greenwood Ave N	Westminster Way N	N 155th St	60	22-39	W-E	5	3	2.5	0	0	5	10	0	10	5	8	0.5	5	5	1	60	38	West side pedestrian improvements are trail-like due to topographic separation
Collector Arterial	Greenwood Ave N	N 155th St	N 160th St	60	22-32	W-E	0.5	5	5	0.5	0	5	10	0	10	5	8	0.5	5	5	0.5	60	38	
Collector Arterial	Greenwood Ave N	N Innis Arden Way	Carlyle Hall Rd N	60	22	W-E	0	8	5	0.5	8	0	10	0	10	0	8	0.5	5	5	0	60	36	
Local Primary Street	Innis Arden Drive	Ridgefield Rd NW	NW Richmond Beach Rd	60-120	20	SE-NW	1	5	5.5	0.5	0	0	13	0	13	0	8	0.5	5.5	5	1	58	34	Sidewalk with no amenity zone across culvert/bridge
Collector Arterial	Linden Ave N	N 175th St	N 185th St	60	20-26	W-E	1	5	5	0.5	8	0	11	0	11	0	8	0.5	5	8	1	64	38	This is a Green Link Street per the Town Center Code
Collector Arterial	Midvale Ave N	N 175th St	N 185th St	20-60	22-37	W-E	0	0	0	0.5	0	0	12	0	10	0	8	0.5	5	10	0.5	46.5	30	17 feet on SCL property for back in angle parking; This is a Storefront Street per the Town Center Code
Minor Arterial	Meridian Ave N	N 205th St	N 145th St	60-105	38-55	W-E	1	5	5.5	0.5	0	5	11	12	11	5	0	0.5	5.5	5	1	68	44	
Collector Arterial	Perkins PI NE	NE 185th St	Perkins Way NE	60	20	SW-NE	1	5	5.5	0.5	8	0	10	0	10	0	8	0.5	5.5	5	1	60	36	
Collector Arterial	Richmond Beach Dr NW	NW 195th	NW 196th	60	20	W-E	0.5	5	5	0.5	8	0	12	0	10	0	8	0.5	5	5	0.5	60	38	
Collector Arterial	Richmond Beach Dr NW	NW 196th St	NW 199th St	60	20	W-E	1	5	5.5	0.5	8	0	10	0	10	0	8	0.5	5.5	5	1	60	36	
Local Primary Street	Ridgefield Rd NW	NW Innis Arden Dr	Springdale Ct NW	60	20	S-N	0.5	8	0	0.5	0	0	13	0	13	0	8	0.5	5	5	0.5	54	34	Add amenity zone to sidewalk on the south side where possible
Collector Arterial	Springdale Ct NW	14th Ave NW	NW 188th St	60	20	W-E	1	5	5.5	0.5	8	0	10	0	10	0	8	0.5	5.5	5	1	60	36	

FUNCTIONAL CLASSIFICATION	STREET NAME	FROM	TO	TOTAL EXISTING RIGHT-OF-WAY	EXISTING CURB TO CURB WIDTH	CROSS-SECTION DIRECTION	BEHIND SIDEWALK	SIDEWALK	AMENITY ZONE	CURB	PARKING	BICYCLE LANE	TRAVEL LANE	CENTER TURN LANE	TRAVEL LANE	BICYCLE LANE	PARKING	CURB	AMENITY ZONE	SIDEWALK	BEHIND SIDEWALK	REQUIRED RIGHT-OF-WAY	PLANNED CURB TO CURB WIDTH	NOTES
Collector Arterial	St. Luke Pl	NW 175th St	Dayton Ave N	60	37	W-E	0	5	2	0.5	8	0	10	0	10	0	8	0.5	5	5	0	54	36	
Principal Arterial	Westminster Way N	Greenwood Ave N	N 155th St	90-125	60-78	W-E	1	8	5.5	0.5	0	0	24	12	24	0	0	0.5	5.5	8	1	90	60	Two travel lanes in each direction. Study needed to determine appropriate cross-section in response to redevelopment at Aurora Square.
Minor Arterial	Westminster Way N	N 155th St	Aurora Ave N	100	60	Cross-section to be determined in conjunction with future redevelopment																		
Local Primary Street	N 152nd St	Aurora Ave N	Approx. 375 feet west of Ashworth Ave N	50-60	20-34	N-S	1	8	5.5	0.5	0	0	12	12	12	0	0	0.5	5.5	8	1	66	36	Each side of the street must dedicate 3 feet; begin on-street parking at Scottish Rite center
Principal Arterial	N 155th St	Westminster Way N	Aurora Ave N	115-220	70-80	Cross-section to be determined in conjunction with future redevelopment																		
Minor Arterial	N 155th St	Aurora Ave N	Midvale Ave N	74-88	47-70	N-S	0	7	4	.5	0	0	12-34	10	20-23	0	0	.5	0	6	0-3	75-88	48-69	
Minor Arterial	N 155th St	Midvale Ave N	Stone Ave N	74	42	N-S	1	8	5.5	0.5	0	5	11	10	11	5	0	0.5	5.5	8	1	72	42	
Minor Arterial	N 155th St	Stone Ave N	I-5	72	42	N-S	1	5	5	0.5	0	5	11	10	11	5	0	0.5	5	8	1	68	42	
Minor Arterial	N 160th St	Greenwood Ave N	Aurora Ave N	50-72	40-43	N-S	1	8	5	0.5	0	5	10	13	10	5	0	0.5	5	8	1	72	43	

FUNCTIONAL CLASSIFICATION	STREET NAME	FROM	TO	TOTAL EXISTING RIGHT-OF-WAY	EXISTING CURB TO CURB WIDTH	CROSS-SECTION DIRECTION	BEHIND SIDEWALK	SIDEWALK	AMENITY ZONE	CURB	PARKING	BICYCLE LANE	TRAVEL LANE	CENTER TURN LANE	TRAVEL LANE	BICYCLE LANE	PARKING	CURB	AMENITY ZONE	SIDEWALK	BEHIND SIDEWALK	REQUIRED RIGHT-OF-WAY	PLANNED CURB TO CURB WIDTH	NOTES
Local Primary Street	N 165th St	Aurora Ave N	Interurban Trail	60	27-36	N-S	1	8	4	0.5	0	0	12	0	12	12	0	0.5	4	8	1	63	36	The cross-section does not have bicycle lanes, it has a 12 foot left turn pocket; redevelopment must dedicate 1.5 feet on both sides and expand the sidewalk width to 8 feet.
Local Primary Street	N 165th St	Interurban Trail	Ashworth Ave N	60	27-36	N-S	1	5	8.5	0.5	0	0	15	0	15	0	0	0.5	8.5	5	1	60	30	
Collector Arterial	N 165th St	Evanston Place N	Aurora Ave N	60	26	N-S	0.5	5	5	0.5	0	5	10	0	10	5	8	0.5	5	5	0.5	60	38	
Local Primary Street	N 167th St	Ashworth Ave N	Meridian Ave N	60	22	N-S	1	5	8.5	0.5	0	0	15	0	15	0	0	0.5	8.5	5	1	60	30	
Collector Arterial	N 172nd St	Fremont Ave N	Dayton Ave N	60	36	N-S	0	5	4	0.5	8	0	10	0	10	0	8	0.5	8	5	1	60	36	
Collector Arterial	N 175th St	Fremont Ave N	Fire Dept	73	42	S-N	1	8	5	0.5	0	5	11	12	11	5	0	0.5	5	5-8	1	70-73	44	
Collector Arterial	N 175th St	Fire Dept	Aurora Ave N	66-71	43-52	N-S	.5	7	4	.5	0	0	22-28	0-10	28	0	0	.5	4	7	.5	82-90	50-66	
Principal Arterial	N 175th St	Aurora Ave N	Midvale Ave N	62	54-55	N-S	1	7	4	.5	0	0	.7-38	12-22	25-29	0	0	.5	4	7	1	112	78-88	
Principal Arterial	N 175th St	Midvale Ave N	Meridian Ave N	70-100	44-60	N-S	1	13	5	0.5	0	0	22	11	22	0	0	0.5	5	13	1	94	55	2 travel lanes in each direction. Wider sidewalks to accommodate bicycles.
Principal Arterial	N 175th St	Meridian Ave N	1st Ave NE	90-159	50-75	N-S	1	13	5	0.5	0	0	33	11	22	0	0	0.5	5	13	1	105	66	Includes a right turn lane at on ramps. Wider sidewalks to accommodate bicycles

FUNCTIONAL CLASSIFICATION	STREET NAME	FROM	TO	TOTAL EXISTING RIGHT-OF-WAY	EXISTING CURB TO CURB WIDTH	CROSS-SECTION DIRECTION	BEHIND SIDEWALK	SIDEWALK	AMENITY ZONE	CURB	PARKING	BICYCLE LANE	TRAVEL LANE	CENTER TURN LANE	TRAVEL LANE	BICYCLE LANE	PARKING	CURB	AMENITY ZONE	SIDEWALK	BEHIND SIDEWALK	REQUIRED RIGHT-OF-WAY	PLANNED CURB TO CURB WIDTH	NOTES
Minor Arterial	N 185th St	Fremont Ave N	Approx. 140 feet west of Aurora Ave N	70-80	56	N-S	1	5 to 8	5	0.5	0	0	22	11	22	0	0	0.5	5	5 to 8	1	67	55	
Minor Arterial	N 185th St	Approx. 140 feet west of Aurora Ave N	Aurora Ave N	60	44	N-S	0	7	0	.5	0	0	22-30	12	32	0	0	.5	4	7	0	83-90	66-74	
Minor Arterial	N 185th St	Aurora Ave N	Midvale Ave N	60	42	N-S	0-8	7	0-4	.5	0	0	22-29	0-12	22-24	0	0	.5	4	12	0	78-92	53-56	
Minor Arterial	N 185th St	Midvale Ave N	Ashworth Ave N	60-72	41-42	N-S	1	8	5.5	0.5	0	5	11	10	11	5	0	0.5	5.5	8	1	72	42	
Minor Arterial	N 185th St	Ashworth Ave N	1st Ave NE	60-70	42	N-S	1	5	5.5	0.5	0	5	11	10	11	5	0	0.5	5.5	5	1	66	42	
Collector Arterial	N 192nd St	Aurora Avenue N	Interurban Trail	60	22-34	N-S	2	13	5	.5	0	0	11	12	11	0	0	.5	0	5	0	60	22-34	
Collector Arterial	N 192nd St	Interurban Trail	Ashworth Avenue N	60	22-26	N-S	11.5	6	3.5	.5	0	0	12	0	18	0	0	.5	0	8	0	60	30	
Collector Arterial	N 195th St	Greenwood Ave N	Fremont Ave N	60-88	22-28	N-S	1	8	5.5	0.5	0	0	13	10	13	0	0	0.5	5.5	8	1	66	36	
Collector Arterial	N 195th St	Fremont Ave N	Linden Ave N	60	30	N-S	1	5	5.5	0.5	8	0	10	0	10	0	8	0.5	5.5	5	1	60	36	
Collector Arterial	N 200th St	1st Ave NW	Whitman Ave N	58-60	32-36	N-S	0.5	5	5	0.5	12		10	0	10	12		0.5	5	5	0.5	66	44	
Collector Arterial	N 200th St	Whitman Ave N	Aurora Ave N	60	37-40	N-S	1-2	7-8	4.5	.5	0	0	11	12	11	0	0	.5	4.5	7-8	1-2	62-64	34	
Collector Arterial	N 200th St	Aurora Ave N	Approx. 720 feet east of Aurora Ave N	60	40	N-S	0	10	0	.5	0	0	12	12-16	12	0	0	.5	4	7-8	0-1	60-64	36-40	



FUNCTIONAL CLASSIFICATION	STREET NAME	FROM	TO	TOTAL EXISTING RIGHT-OF-WAY	EXISTING CURB TO CURB WIDTH	CROSS-SECTION DIRECTION	BEHIND SIDEWALK	SIDEWALK	AMENITY ZONE	CURB	PARKING	BICYCLE LANE	TRAVEL LANE	CENTER TURN LANE	TRAVEL LANE	BICYCLE LANE	PARKING	CURB	AMENITY ZONE	SIDEWALK	BEHIND SIDEWALK	REQUIRED RIGHT-OF-WAY	PLANNED CURB TO CURB WIDTH	NOTES
Collector Arterial	N 200th St	Approx. 720 feet east of Aurora Ave N	Ashworth Ave N	60	50	N-S	0.5	8	5	0.5	0	5	11	10	11	5	0	0.5	5	8	0.5	70	42	All widening to the north
Collector Arterial	N 200th St	Ashworth Ave N	Meridian Ave N	60	40		0	5	5	0.5	7	5	11	0	11	5	0	0.5	5	5	0	60	39	
Collector Arterial	NE 150th St	15th Ave NE	20th Ave NE	60	30-36	N-S	1	8	5	0.5	0	5	10	0	10	5	8	0.5	5	5	1	64	38	
Collector Arterial	NE 150th St	20th Ave NE	25th Ave NE	60	39	N-S	5	2-10	0	0	0	5	10	0	10	5	8	0.5	5	5	1	62	38	City has constructed meandering path on the north side, resulting in a varying sidewalk/amenity zone width
Minor Arterial	NE 155th St	I-5	15th Ave NE	60-72	41	N-S	1	5	5	0.5	0	5	11	10	11	5	0	0.5	5	8	1	68	42	
Collector Arterial	NE 165th St	5th Ave NE	10th Ave NE	60	30-45	N-S	1	5	5.5	0.5	8	0	10	0	10	0	8	0.5	5.5	5	1	60-65	36	
Collector Arterial	NE 165th St	10th Ave NE	15th Ave NE	60	44	N-S	1	8	5.5	0.5	8	0	10	0	10	0	8	0.5	5.5	5	1	63	36	
Collector Arterial	NE 168th St	15th Ave NE	25th Ave NE	60-64	22-29	N-S	1	5	5.5	0.5	8	0	10	0	10	0	8	0.5	5.5	5	1	60	36	
Collector Arterial	NE 168th St	25th Ave NE	25th Ave NE	64	27	W-E/ S-N	0.5	5	5	0.5	0	5	10	0	10	5	8	0.5	5	5	0.5	60	38	
Collector Arterial	NE 171st St	22nd Ave NE	25th Ave NE	60	20	W-E/ S-N	0.5	5	5	0.5	8	0	11	0	11	0	8	0.5	5	5	0.5	60	38	
Principal Arterial	NE 175th St	1st Ave NE	Approx. 120 feet west of 3rd Ave NE	90-159	50-75	N-S	1	13	5	0.5	0	0	33	11	22	0	0	0.5	5	13	1	105	66	Includes a right turn lane at on ramps. Wider sidewalks to accommodate bicycles
Principal Arterial	NE 175th St	Approx. 120 feet west of 3rd Ave NE	15th Ave NE	60-100	26-56	N-S	1	13	5	0.5	0	0	22	11	22	0	0	0.5	5	13	1	94	55	2 travel lanes in each direction. Wider sidewalks to accommodate bicycles.

FUNCTIONAL CLASSIFICATION	STREET NAME	FROM	TO	TOTAL EXISTING RIGHT-OF-WAY	EXISTING CURB TO CURB WIDTH	CROSS-SECTION DIRECTION	BEHIND SIDEWALK	SIDEWALK	AMENITY ZONE	CURB	PARKING	BICYCLE LANE	TRAVEL LANE	CENTER TURN LANE	TRAVEL LANE	BICYCLE LANE	PARKING	CURB	AMENITY ZONE	SIDEWALK	BEHIND SIDEWALK	REQUIRED RIGHT-OF-WAY	PLANNED CURB TO CURB WIDTH	NOTES
Collector Arterial	NE 175th St	15th Ave NE	Approx. 300 feet east of 15th Ave NE	60-81	40	S-N	0	10		0	0	22	0	22	0	0	10	0	60	44	Two travel lanes in each direction, 8 feet of north sidewalk in ROW, 2 feet on private property			
Collector Arterial	NE 175th St	Approx. 300 feet east of 15th Ave NE	NE 172nd St	60	24-33	W-E/ S-N	0.5	5	5	0.5	8	0	11	0	11	0	8	0.5	5	5	0.5	60	38	
Minor Arterial	NE 178th St	24th Pl NE	25th Ave NE	60	30	W-E	0.5	5	5	0.5	8	5	10	0	10	5	0	0.5	5	5	0.5	60	38	
Collector Arterial	NE 180th St	10th Ave NE	14th Ave NE	60	32	N-S	0.5	8	0	0.5	8	0	10	0	13	0	8	0.5	4	7.5	0	60	39	
Collector Arterial	NE 180th St	14th Ave NE	15th Ave NE	60	35	N-S	0.5	8	4.5	0.5	0	0	13	0	13	0	8	0.5	4	8	0	60	34	
Minor Arterial	NE 185th St	1st Ave NE	10th Ave NE	60-260 +	42	N-S	1	5	5.5	0.5	0	5	11	10	11	5	0	0.5	5.5	5	1	66	42	No amenity zones required across the bridge over I-5.
Minor Arterial	NE 196th St	15th Ave NE	Forest Park Dr NE	60-80	36-39	N/ W-S/ E	1	5	5	0.5	0	0	12	0	12	0	10-15	0	0	0	0	45.5-49.5	24	Parking to be accommodated on SE side where possible
Minor Arterial	NE 196th St	Bridge		60-80	36-39	N-S	11 (curb, walkway and railing)				0	0	12	0	12	0	0	0.5	2.5 (guardrail)			38	24	
Collector Arterial	NE Perkins Way	10th Ave NE	15th Ave NE	60	26-36						27											40	27	Cross section will be no less than 40 feet. It will consist of 27 feet of asphalt to accommodate two 12 foot travel lanes and one 5 foot bicycle lane in each uphill direction, a pedestrian walkway on the north side of the roadway and widened shoulder and parking where possible.

FUNCTIONAL CLASSIFICATION	STREET NAME	FROM	TO	TOTAL EXISTING RIGHT-OF-WAY	EXISTING CURB TO CURB WIDTH	CROSS-SECTION DIRECTION	BEHIND SIDEWALK	SIDEWALK	AMENITY ZONE	CURB	PARKING	BICYCLE LANE	TRAVEL LANE	CENTER TURN LANE	TRAVEL LANE	BICYCLE LANE	PARKING	CURB	AMENITY ZONE	SIDEWALK	BEHIND SIDEWALK	REQUIRED RIGHT-OF-WAY	PLANNED CURB TO CURB WIDTH	NOTES
Collector Arterial	NE Perkins Way	15th Ave NE	18th Ave NE	60	25-41	W-E/ S-N	0.5	5	5	0.5	8	5	10	0	10	5	0	0.5	5	5	0.5	60	38	
Minor Arterial	NE 205th Street	19th Ave NE	30th Ave NE	N/A	N/A	CL-S	In Mountlake Terrace						0	10	12		0.5	0	7.5	0	30	22		
Collector Arterial	NW 167th St	10th Ave NW	15th Ave NW	60	20	N-S	1	5	5.5	0.5	8	0	10	0	10	0	8	0.5	5.5	5	1	60	36	
Collector Arterial	NW 175th St	St. Luke's Pl	3rd Ave NW	60	28	S-N	1	5	5.5	0.5	8	0	10	0	10	0	8	0.5	5.5	5	1	60	36	Provide amenity zone on the south where feasible and allow the sidewalk to meander due to topography.
Collector Arterial	NW 175th St	3rd Ave NW	6th Ave NW	60	28-34	S-N	0	5	3.5	0.5	8	0	10	0	10	0	8	0.5	4	5	0	54.5	36	
Collector Arterial	NW 175th St	6th Ave NW	10th Ave NW (s leg)	60	28	S-N	0	8	0	0.5	0	0	12	0	13	0	8	0.5	0	8	0	50	33	Parking on the north side to consist of parking pullouts where feasible
Local Primary Street	NW 175th St	10th Ave NW (s leg)	10th Ave NW (n leg)	60	20	S-N	0	8	0	0.5	0	0	13	0	13	0	0	0.5	5	8	0	48	26	
Local Primary Street	NW 175th St	10th Ave NW (n leg)	14th Ave NW	60	20	S-N	1	5	7.5	0.5	0	0	16	0	16	0	0	0.5	7.5	5	1	60	32	
Local Primary Street	NW 180th St	3rd Ave NW	6th Ave NW	60	32	N-S	1	5	8.5	0.5	0	0	15	0	15	0	0	0.5	8.5	5	1	60	30	
Collector Arterial	NW 180th St	6th Ave NW	8th Ave NW	50-60	20-35	S-N	1	5	5.5	0.5	0	0	14	0	14	0	8	0.5	5.5	5	1	60	36	
Local Primary Street	NW 180th St	8th Ave NW	10th Ave NW	60	20	N-S	1	5	5.5	0.5	8	0	10	0	10	0	8	0.5	5.5	5	1	60	36	

FUNCTIONAL CLASSIFICATION	STREET NAME	FROM	TO	TOTAL EXISTING RIGHT-OF-WAY	EXISTING CURB TO CURB WIDTH	CROSS-SECTION DIRECTION	BEHIND SIDEWALK	SIDEWALK	AMENITY ZONE	CURB	PARKING	BICYCLE LANE	TRAVEL LANE	CENTER TURN LANE	TRAVEL LANE	BICYCLE LANE	PARKING	CURB	AMENITY ZONE	SIDEWALK	BEHIND SIDEWALK	REQUIRED RIGHT-OF-WAY	PLANNED CURB TO CURB WIDTH	NOTES
Collector Arterial	NW 188th St	15th Ave NW	Springdale Ct NW	60	20	N-S	1	5	5.5	0.5	8	0	10	0	14	0	0	0.5	9.5	5	1	60	32	
Collector Arterial	NW 195th St	8th Ave NW	Greenwood Ave N	50-60	28-32	N-S	1	8	5.5	0.5	0	0	13	10	13	0	0	0.5	5.5	8	1	66	36	
Minor Arterial	NW 195th St	15th Ave NW	20th Ave NW	60-85	44	Curb to curb cross-section to remain the same until corridor study is complete.																		
Local Primary Street	NW 195th St	Richmond Beach Dr NW	NW 196th	60	27	NW-SE	0.5	5	5	0.5	8	0	10	0	12	0	8	0.5	5	5	0.5	60	38	
Collector Arterial	NW 196th St	20th Ave NW	24th Ave NW	64-74	42-44	Curb to curb cross-section to remain the same until corridor study is complete.																		
Collector Arterial	NW 196th St	Richmond Beach Dr NW	24th Ave NW	60	26-32	N-S	0.5	5	5	0.5	8	5	10	0	10	5	8	0.5	5	5	0.5	68	46	
Collector Arterial	NW 200th St	1st Ave NW	3rd Ave NW	60	30	N-S	0.5	5	5	0.5	12		10	0	10	12		0.5	5	5	0.5	66	44	
Collector Arterial	NW 205th Street	3rd Ave NW	8th Ave NW	40-50	19-20	N-S	0.5	8	0	0.5	0	0	11	0	11	0	8	0.5	5	5	0.5	50	30	
Collector Arterial	NW Innis Arden	Greenwood Ave N	Approx. 450 feet east of 6th Ave NW	80	22	To Be Determined in conjunction with Shoreline Community College Master Development Permit application																		
Collector Arterial	NW Innis Arden	Approx. 450 feet east of 6th Ave NW	6th Ave NW	80	22	W-E	0.5	8	5	0.5	8	0	10	0	14	0	0	0.5	5	8	0.5	60	32	8 foot width on south/west side is shoulder
Collector Arterial	NW Innis Arden	6th Ave NW	10th Ave NW	60-81	21-24	W-E	0	0	0	0	8	0	10	0	14	0	0	0.5	5	8	0.5	46	32	
Minor Arterial	NW Richmond Beach Rd	Fremont Ave N	2nd Ave NW	80-110	44	Curb to curb cross-section to remain the same until corridor study is complete.																		

FUNCTIONAL CLASSIFICATION	STREET NAME	FROM	TO	TOTAL EXISTING RIGHT-OF-WAY	EXISTING CURB TO CURB WIDTH	CROSS-SECTION DIRECTION	BEHIND SIDEWALK	SIDEWALK	AMENITY ZONE	CURB	PARKING	BICYCLE LANE	TRAVEL LANE	CENTER TURN LANE	TRAVEL LANE	BICYCLE LANE	PARKING	CURB	AMENITY ZONE	SIDEWALK	BEHIND SIDEWALK	REQUIRED RIGHT-OF-WAY	PLANNED CURB TO CURB WIDTH	NOTES
Minor Arterial	NW Richmond Beach Rd	2nd Ave NW	8th Ave NW	60-80	44-54	N-S	1	5 to 8	5	0.5	0	5	22	12	22	5	0	0.5	5	5 to 8	1	89-95	66	
Minor Arterial	NW Richmond Beach Rd	8th Ave NW	15th Ave NW	60-83	44	Curb to curb cross-section to remain the same until corridor study is complete.																		

FUNCTIONAL CLASSIFICATION	STREET NAME	FROM	TO	TOTAL EXISTING RIGHT-OF-WAY	EXISTING CURB TO CURB WIDTH	CROSS-SECTION DIRECTION	BEHIND SIDEWALK	SIDEWALK	AMENITY ZONE	CURB	PARKING	BICYCLE LANE	TRAVEL LANE	CENTER TURN LANE	TRAVEL LANE	BICYCLE LANE	PARKING	CURB	AMENITY ZONE	SIDEWALK	BEHIND SIDEWALK	REQUIRED RIGHT-OF-WAY	PLANNED CURB TO CURB WIDTH	NOTES		
LOCAL SECONDARY STREETS																										
Local Secondary Street	Generic Cross-Section			Varies	Varies		1	5	7.5	0.5	0	0	16	0	16	0	0	0.5	7.5	5	1	60	32	Five feet is the standard sidewalk width adjacent to single family residential land uses and eight feet is the standard sidewalk width adjacent to all land uses other than single family residential. Increased width may be required if determined by a traffic study.		
Local Street - Storefront Street	N 178th St, N 180th St, N 183rd St	Town Center Boundaries				N-S	0.5	8	5	0.5	8	0	10	0	10	0	8	0.5	5	8	0.5	64	36			
Local Street - Greenlink Street	Stone Ave N	Town Center Boundaries				W-E	0.5	8	5	0.5	0	0	16	0	16	0	0	0.5	5	8	0.5	60	32	Combined travel lanes/on-street parking		
Local Street	NW 200th Ave	3rd Ave NW	8th Ave NW			N-S	1	5	5.5	0.5	0	0	16	0	16	0	0	0.5	5.5	5	1	56	32	Combined travel lanes/on-street parking		

FUNCTIONAL CLASSIFICATION	STREET NAME	FROM	TO	TOTAL EXISTING RIGHT-OF-WAY	EXISTING CURB TO CURB WIDTH	CROSS-SECTION DIRECTION	BEHIND SIDEWALK	SIDEWALK	AMENITY ZONE	CURB	PARKING	BICYCLE LANE	TRAVEL LANE	CENTER TURN LANE	TRAVEL LANE	BICYCLE LANE	PARKING	CURB	AMENITY ZONE	SIDEWALK	BEHIND SIDEWALK	REQUIRED RIGHT-OF-WAY	PLANNED CURB TO CURB WIDTH	NOTES
Local Secondary Street	Firlands Way N	N 185th St	N 188th St	92	25	SW-NE	0.5	10	5	0.5	17	0	12	0	12	0	17	0.5	5	10	0.5	90	58	This is a Storefront Street per the Town Center Code; redesign the intersection at Firlands & Linden
Local Secondary Street	N 152nd St	Approx. 375 feet west of Ashworth Ave N	Ashworth Ave N	60	30	N-S	1	5	11.5	0.5	0	0	12	0	12	0	0	0.5	11.5	5	1	60	24	Amenity zone width needs to be flexible to accommodate topography.
Local Secondary Street	N 195th St	Ashworth Ave N	Wallingford Ave N	60	40	N-S	1	5	5	0.5	8	0	10	0	10	0	17	0.5	5	8	1	71	45	The south side must dedicate 11 feet. Less ROW is needed if parallel parking is installed on-street instead of angle-in parking.
Local Secondary Street	N 195th St	Wallingford Ave N	Meridian Ave N	60	30	N-S	1	5	7	0.5	0	0	15	0	15	0	0	0.5	7	8	1	60	30	

Page intentionally left blank.





# APPENDIX G – RIGHT-OF-WAY STREET TREE LIST



Page intentionally left blank.

### SECTION 1.01 LARGE COLUMNAR TREES

Scientific & Common Name	Mature Height (ft)	Spread (ft)	Under Wires/View Covenants	Min Strip Width (ft)	Flower Color	Fall Color	Comments
<i>Acer nigrum</i> 'Green Column' Green Column Black Sugar Maple	50	10	No	6	N/A		Good close to buildings
<i>Ginkgo biloba</i> 'Princeton Sentry' Princeton Sentry Ginkgo	40	15	No	6	N/A		Very narrow growth.
<i>Nyssa sylvatica</i> Tupelo	60	20	No	6	N/A		Handsome chunky bark – <a href="#">Great Plant Pick</a>
<i>Quercus</i> 'Crimschmidt' Crimson Spire Oak	45	15	No	6	N/A		Hard to find in the nursery trade
<i>Quercus frainetto</i> Italian Oak	50	30	No	6	N/A		Drought resistant – beautiful green, glossy leaves in summer. <a href="#">Great Plant Pick</a>
<i>Quercus robur</i> 'fastigiata' Skyrocket Oak	40	15	No	6	N/A		Columnar variety of oak
<i>Taxodium distichum</i> 'Mickelson' Shawnee Brave Bald Cypress	55	20	No	6	N/A		Deciduous conifer - tolerates city conditions

### SECTION 1.02



### SECTION 1.03 LARGE TREES

Scientific & Common Name	Mature Height (ft)	Spread (ft)	Under Wires/View Covenants	Min Strip Width (ft)	Flower Color	Fall Color	Comments
<i>Acer saccharum</i> 'Bonfire' Bonfire Sugar Maple	50	40	No	6	N/A		Fastest growing sugar maple
<i>Acer saccharum</i> 'Commemoration' Commemoration Sugar Maple	50	35	No	6	N/A		Resistant to leaf tatter. <a href="#">Great Plant Pick</a>
<i>Acer saccharum</i> 'Green Mountain' Green Mountain Sugar Maple	45	35	No	6	N/A		Reliable fall color. <a href="#">Great Plant Pick</a>
<i>Acer saccharum</i> 'Legacy' Legacy Sugar Maple	50	35	No	5	N/A		Limited use - where sugar maple is desired in limited planting strip area. <a href="#">Great Plant Pick</a>

Aesculus flava Yellow Buckeye	60	40	No	6			Least susceptible to leaf blotch – large fruit – fall color is varied, but quite beautiful
Cercidiphyllum japonicum Katsura Tree	40	40	No	6	N/A		Needs lots of water when young – can produce large surface roots. <a href="#">Great Plant Pick</a>
Fagus sylvatica Green Beech	50	40	No	6	N/A		Silvery-grey bark
Fagus sylvatica 'Asplenifolia' Fernleaf Beech	60	50	No	6	N/A		Beautiful cut leaf. <a href="#">Great Plant Pick</a>
Ginkgo biloba 'Magyar' Magyar Ginkgo	50	25	No	6	N/A		more upright and narrow than 'Autumn Gold'
Gymnocladus dioicus 'Espresso' Espresso Kentucky Coffee	50	35	No	6	N/A		Very coarse branches - extremely large bi-pinnately compound leaves
Liriodendron tulipifera Tulip Tree	60	30	No	8	N/A		Fast-growing tree – can get very large in open conditions
Metasequoia glyptostroboides Dawn Redwood	50	25	No	6	N/A		Fast growing deciduous conifer. <a href="#">Great Plant Pick</a>
Quercus bicolor Swamp White Oak	60	45	No	8	N/A		Interesting shaggy peeling bark
Quercus coccinea Scarlet Oak	60	40	No	6	N/A		Best oak for fall color
Quercus garryana Oregon Oak	50	40	No	8	N/A		Native to Pacific Northwest. <a href="#">Great Plant Pick</a>
Quercus imbricaria	60	50	No	6	N/A		Nice summer foliage









Shingle Oak							- leaves can persist throughout the winter
Quercus muhlenbergii Chestnut Oak	60	50	No	6	N/A		coarsely toothed leaf
Quercus robur English Oak	60	40	No	8	N/A		Large, sturdy tree. Acorns do not need dormant cold period to germinate, so can be invasive.
Quercus rubra Red Oak	60	45	No	8	N/A		Fast growing oak – large tree that needs space
Quercus velutina Black Oak	60	50	No	8	N/A		More drought tolerant than red oak
Taxodium distichum Bald Cypress	55	35	No	8	N/A		A deciduous conifer, broadly spreading when mature – columnar when young. <a href="#">Great Plant Pick</a>
Ulmus 'Homestead' Homestead Elm	60	35	No	6	N/A		Complex hybrid - close in form to American elm - Resistant to Dutch elm disease

## SECTION 1.04 LARGE TREES – CONTINUED

Scientific & Common Name	Mature Height (ft)	Spread (ft)	Under Wires/View Covenants	Min Strip Width (ft)	Flower Color	Fall Color	Comments
<i>Ulmus</i> 'Frontier' Frontier Elm	50	35	No	6	N/A		Resistant to Dutch elm disease
<i>Zelkova serrata</i> 'Greenvase' Green Vase Zelkova	45	40	No	6	N/A		Attractive exfoliating bark provides Winter appeal. Dark green leaves turn orange-red and purple in Fall. <a href="#">Great Plant Pick</a>
<i>Zelkova serrata</i> 'Village Green' Village Green Zelkova	40	40	No	6	N/A		Green Vase, Mussichino and Halka are improved forms. <a href="#">Great Plant Pick</a>

## SECTION 1.05

## SECTION 1.06 MEDIUM / LARGE TREES

Scientific & Common Name	Mature Height (ft)	Spread (ft)	Under Wires/View Covenants	Min Strip Width (ft)	Flower Color	Fall Color	Comments
<i>Acer campestre</i> Hedge Maple	50	30	No	5	N/A		Contrary to its name, this is not a small tree – nice overall shape and structure
<i>Acer campestre</i> 'Evelyn' Queen Elizabeth Hedge Maple	40	30	No	5	N/A		More upright branching than the species.
<i>Acer freemanii</i> 'Autumn Blaze' Autumn Blaze Maple	50	40	No	6	N/A		Cross between red and silver maple – fast growing with good fall color
<i>Acer miyabei</i> 'Morton' State Street Maple	40	30	No	6	N/A		Similar to, but faster growing and larger than Hedge maple
<i>Acer pseudoplatanus</i> 'Atropurpureum' Spaethii Maple	40	30	No	5	N/A		Leaves green on top purple underneath.
<i>Aesculus x carnea</i> 'Briotii' Red Horsechestnut	30	35	No	6			Resists heat and drought better than other horsechestnuts
<i>Betula jacquemontii</i> Jacquemontii Birch	40	30	No	5	N/A		White bark makes for good winter interest – best for aphid resistance, but does have issues with Bronze Birch Borer

<i>Ginkgo biloba</i> 'Autumn Gold' Autumn Gold Ginkgo	45	35	No	6	N/A		Narrow when young
---	----	----	----	---	-----	---	-------------------

**SECTION 1.07**



**SECTION 1.08 MEDIUM / LARGE TREES - CONTINUED**

Scientific & Common Name	Mature Height (ft)	Spread (ft)	Under Wires/View Covenants	Min Strip Width (ft)	Flower Color	Fall Color	Comments
<i>Nothofagus antarctica</i> Antarctic Beech	50	35	No	5	N/A		Rugged twisted branching and petite foliage – difficult to find in the nursery trade
<i>Tilia americana</i> 'Redmond' Redmond Linden	50	30	No	8	N/A		Pyramidal, needs extra water when young
<i>Tilia cordata</i> 'Greenspire' Greenspire Linden	40	30	No	6	N/A		Symmetrical, pyramidal form – sometimes has structural issues due to tight branch attachments
<i>Ulmus parvifolia</i> 'Emer II' Allee Elm	45	35	No	5	N/A		Exfoliating bark and nice fall color – Resistant to Dutch Elm Disease

**SECTION 1.09**

**SECTION 1.10 MEDIUM COLUMNAR TREES**





















Scientific & Common Name	Mature Height (ft)	Spread (ft)	Under Wires/View Covenants	Min Strip Width (ft)	Flower Color	Fall Color	Comments
<i>Carpinus betulus</i> 'Fastigiata' Pyramidal European Hornbeam	40	15	No	5	N/A		Broadens when older. <a href="#">Great Plant Pick</a>
<i>Fagus sylvatica</i> 'Dawyck Purple' Dawyck Purple Beech	40	12	No	6	N/A		Purple foliage.
<i>Liriodendron tulipifera</i> 'Fastigiatum' Columnar Tulip Tree	40	10	No	6			Good next to buildings – can have problems with tight branch angles. <a href="#">Great Plant Pick</a>
<i>Malus 'Tschonoskii'</i> Tschonoskii Crabapple	30	15	Yes	5			Sparse green fruit, pyramidal
<i>Oxydendron arboreum</i> Sourwood	35	12	No	5			Consistent and brilliant fall color. <a href="#">Great Plant Pick</a>

<i>Pyrus calleryana</i> 'Cambridge' Cambridge Pear	40	15	No	5			Narrow tree with better branch angles and form than the species – brittle limbs may be a problem with ice or wet snow
--	----	----	----	---	--	---	---

### SECTION 1.11 MEDIUM TREES

Scientific & Common Name	Mature Height (ft)	Spread (ft)	Under Wires/Vie w Covenants	Min Strip Width (ft)	Flower Color	Fall Color	Comments
<i>Acer grandidentatum</i> 'Schmidt' Rocky Mt. Glow Maple	25	20	Yes	5	N/A		Intense red fall color - Limited availability in nursery trade
<i>Acer truncatum</i> x <i>A. platanoides</i> 'Keithsform' Norwegian Sunset Maple	35	25	No	5	N/A		Reliable fall color - nice reddish orange
<i>Acer truncatum</i> x <i>A. platanoides</i> 'Warrensred' Pacific Sunset Maple	30	25	Yes	5	N/A		Limited use under higher wires
<i>Betula albosinensis</i> <i>var septentrionalis</i> Chinese Red Birch	40	35	No	5	N/A		White and pink peeling bark. <a href="#">Great Plant Pick</a>
<i>Carpinus caroliniana</i> American Hornbeam	25	20	Yes	5	N/A		Outstanding fall color (variable – yellow, orange, red) – nice little tree. <a href="#">Great Plant Pick</a>
<i>Cladrastis kentukea</i> Yellowwood	40	40	No	5			White flowers in spring, resembling wisteria flower – blooms profusely only every 2 to 4 years – yellow/gold fall color
<i>Cornus controversa</i> 'June Snow' Giant Dogwood	40	30	No	5			Frothy, 6-inch clusters of white flowers in June – <a href="#">Great Plant Pick</a>
<i>Crataegus crus-galli</i> 'Inermis' Thornless Cockspur Hawthorne	25	30	Yes	5			Red persistent fruit
<i>Cornus</i> 'Eddie's White Wonder' Eddie's White Wonder Dogwood	30	20	Yes	5			A hybrid of <i>C. florida</i> and <i>C. nuttallii</i>
<i>Crataegus</i> x <i>lavalii</i> Lavalle Hawthorne	25	20	Yes	5			Thorns on younger trees. <a href="#">Great Plant Pick</a>



<i>Davidia involucrata</i> Dove Tree	40	30	No	5		N/A	Large, unique flowers in May. <a href="#">Great Plant Pick</a>
<i>Eucommia ulmoides</i> Hardy Rubber Tree	50	40	No	6	N/A	N/A	Dark green, very shiny leaves – insignificant fall color
<i>Fagus sylvatica</i> 'Rohanii' Purple Oak Leaf Beech	50	30	No	6	N/A	N/A	Attractive purple leaves with wavy margins. <a href="#">Great Plant Pick</a>
<i>Halesia monticola</i> Mountain Silverbell	45	25	No	5			Attractive small white flower
<i>Halesia tetraptera</i> Carolina Silverbell	35	30	No	5			Attractive bark for seasonal interest
<i>Koelreuteria paniculata</i> Goldenrain Tree	30	30	Yes	5			Midsummer blooming – slow growing. <a href="#">Great Plant Pick</a>
<i>Magnolia denudata</i> Yulan Magnolia	40	40	No	5		N/A	6” inch fragrant white flowers in spring. <a href="#">Great Plant Pick</a>
<i>Magnolia grandiflora</i> 'Victoria' Victoria Evergreen Magnolia	25	20	Yes	5		N/A	Evergreen magnolia – can be damaged in years with wet, heavy snow. <a href="#">Great Plant Pick</a>
<i>Magnolia kobus</i> 'Wada's Memory' Wada's Memory Magnolia'	30	20	Yes	5			Does not flower well when young. <a href="#">Great Plant Pick</a>
<i>Ostrya virginiana</i> Ironwood	40	25	No	5	N/A		Hop like fruit – slow growing
<i>Phellodendron amurense</i> 'Macho' Macho Cork Tree	40	40	No	5	N/A		This variety is fruitless – fall color can be varied. High drought tolerance
<i>Prunus cerasifera</i> 'Krauter Vesuvius' Vesuvius Flowering Plum	30	20	Yes	5		N/A	Burgundy colored leaves – tree best used as an accent rather than in mass plantings
<i>Pterostyrax hispida</i> Fragrant Epaulette Tree	40	30	No	5			Pendulous creamy white flowers – fragrant – difficult to find in the nursery trade
<i>Quercus Ilex</i> Holly Oak	40	30	No	5	N/A	N/A	Evergreen oak - Underside of leaf is silvery-white. Often has a prominent umbrella form
<i>Rhamnus purshiana</i> Cascara	30	20	Yes	5	N/A		<i>Native tree</i> – fall color depends on exposure – purplish fruit feeds many native birds
<i>Robinia x ambigua</i> Pink Idaho Locust	35	25	No	5			Fragrant flowers. Sterile variety. Drought tolerant. Some varieties will sucker profusely.
<i>Sorbus x hybridia</i> Oakleaf Royal Mt. Ash	30	20	Yes	5			It has leaves which are similar to English oak, and interesting bark

							for seasonal features.
<i>Styrax japonica</i> Japanese Snowbell	25	25	Yes	5			Reliable and easy to grow, it has plentiful, green ½” inch seeds. Flowers similar to lily in the valley. <a href="#">Great Plant Pick</a>
<i>Tilia cordata</i> ‘De Groot’ De Groot Littleleaf Linden	30	20	Yes	5	N/A		One of the smaller stature littleleaf lindens.
<i>Tilia cordata</i> ‘Chancole’ Chancellor Linden	35	20	No	6	N/A		Pyramidal when young. Fragrant flowers that attract bees.
<i>Ulmus parvifolia</i> ‘Emer I’ Athena Classic Elm	30	35	No	5	N/A		High resistance to Dutch Elm Disease. Drought resistant. Cinnamon colored exfoliating bark for seasonal interest.

## SECTION 1.12



























### SECTION 1.13 SMALL COLUMNAR TREES











Scientific & Common Name	Mature Height (ft)	Spread (ft)	Under Wires/Vie w Covenants	Min Strip Width (ft)	Flower Color	Fall Color	Comments
<i>Maackia amurensis</i> Amur Maackia	30	20	Yes	5		N/A	Interesting exfoliating bark – flowering in June or July - varies in intensity from year to year
<i>Malus</i> ‘Adirondack’ Adirondack Crabapple	20	10	Yes	5			Very resistant to apple scab – one of the narrowest crabapples – persistent reddish ¼” fruit. <a href="#">Great Plant Pick</a>
<i>Malus</i> ‘Red Barron’ Red Barron Crabapple	20	10	Yes	5			Deep pink blossom and persistent red berries for seasonal interest
<i>Prunus serrulata</i> ‘Amanogawa’ Amanogawa Flowering Cherry	20	8	Yes	6			Pinkish flower bud, changing to white flower.
<i>Sorbus americana</i> ‘Dwarf-crown’ Red Cascade Mountain Ash	20	10	Yes	5			Nice winter form - Red berries persistent in clusters

SECTION 1.14

SECTION 1.15 SMALL TREES

Scientific & Common Name	Mature Height (ft)	Spread (ft)	Under Wires/Vie w Covenants	Min Strip Width (ft)	Flower Color	Fall Color	Comments
<i>Acer buegerianum</i> Trident Maple	30	30	Yes	5	N/A		Somewhat shrub-like – must train to a single stem – interesting bark. <a href="#">Great Plant Pick</a>
<i>Acer circinatum</i> Vine Maple	25	25	Yes	5	N/A		<i>Native tree.</i> Avoid using on harsh sites. <a href="#">Great Plant Pick</a>
<i>Acer ginnala</i> 'Flame' Flame Amur Maple	25	20	Yes	5			Clusters of small cream colored flowers in spring – very fragrant. Nice fall color. Informal branch structure.
<i>Acer griseum</i> Paperbark Maple	30	20	Yes	5	N/A		Peeling cinnamon colored bark for seasonal interest. <a href="#">Great Plant Pick</a>
<i>Acer palmatum</i> Japanese Maple	20	25	Yes	5	N/A		Many varieties available – select larger varieties for street planting
<i>Acer triflorum</i> Three-Flower Maple	25	20	Yes	5	N/A		Multi seasonal interest with tan, exfoliating bark and red, orange/red fall color. <a href="#">Great Plant Pick</a>
<i>Amelanchier grandiflora</i> 'Princess Diana' Princess Diana Serviceberry	20	15	Yes	4			Good for narrower planting strips
<i>Amelanchier x grandiflora</i> 'Autumn Brilliance' Autumn Brilliance Serviceberry	20	15	Yes	4			Good for narrower planting strips – reliable bloom and fall color
<i>Arbutus unedo</i> 'Marina' Strawberry Tree	25	20	Yes	5		N/A	Substitute for Pacific madrone – can suffer severe damage or death due to cold weather - evergreen
<i>Carpinus japonica</i> Japanese Hornbeam	20	25	Yes	5	N/A		Wide spreading, slow growing – fall color is not outstanding. <a href="#">Great Plant Pick</a>
<i>Cercis canadensis</i> Eastern Redbud	25	30	Yes	5			Deep pink flowers on bare twigs in spring

<i>Cercis siliquastrum</i> Judas Tree	25	30	Yes	5			Deep pink flowers on bare twigs in spring – drought resistant
<i>Cornus alternifolia</i> Pagoda Dogwood	25	25	Yes	5			Small white flowers in flat clusters – fall color is varied. <a href="#">Great Plant Pick</a>
<i>Cornus kousa</i> 'Chinensis' Kousa Dogwood	20	20	Yes	4			Does not do well on harsh, dry sites. <a href="#">Great Plant Pick</a>
<i>Cotinus obovatus</i> American Smoke Tree	25	25	Yes	4			Showy pinkish panicles of flowers in the spring – reddish purple leaves on some varieties. <a href="#">Great Plant Pick</a>
<i>Lagerstroemia 'tuscarora'</i> Tuscarora Hybrid Crape Myrtle	20	20	Yes	4			Light cinnamon brown bark lends year round interest – drought resistant – likes a warm site
<i>Magnolia 'Elizabeth'</i> Elizabeth Magnolia	30	20	Yes	5		N/A	Yellowish to cream colored flower in spring. <a href="#">Great Plant Pick</a>
<i>Magnolia 'Galaxy'</i> Galaxy Magnolia	25	25	Yes	5			Showy pink flowers. <a href="#">Great Plant Pick</a>
<i>Magnolia x loebneri</i> Loebner Magnolia	20	20	Yes	5			Flower is 'star' shaped rather than tulip like – white to pinkish white in March or April. <a href="#">Great Plant Pick</a>
<i>Malus 'Golden Raindrops'</i> Golden Raindrops Crabapple	20	20	Yes	5			Disease resistant – persistent yellow fruit in fall and winter. <a href="#">Great Plant Pick</a>
<i>Malus 'Donald Wyman'</i> Donald Wyman Crabapple	25	25	Yes	5			Large white blossom – nice green foliage in summer
<i>Malus 'Lancelot' ('Lanzam')</i> Lancelot Crabapple	15	15	Yes	4			Red flower buds, blooming white – red persistent fruit
<i>Parrotia persica</i> Persian Parrotia	30	20	No	5			Blooms before it leafs out – drought tolerant - Varied fall color - reds, oranges and yellows. <a href="#">Great Plant Pick</a>
<i>Prunus 'Frankthrees'</i> Mt. St. Helens Plum	20	20	Yes	5		N/A	Burgundy colored leaves – tree best used as an accent rather than in mass plantings
<i>Prunus 'Newport'</i> Newport Plum	20	20	Yes	5		N/A	Burgundy colored leaves – tree best used as an accent rather than in mass plantings
<i>Prunus 'Snowgoose'</i> Snow Goose Cherry	20	20	Yes	5			This selection sports abundant white flowers and healthy green, disease-

							resistant foliage
<i>Prunus x yedoensis</i> 'Akebono' Akebono Flowering Cherry	25	25	Yes	6			Has masses of large, semi-double, pink flowers – most widely planted cherry in Pacific Northwest
<i>Sorbus alnifolia</i> Korean Mountain Ash	35	30	No	5			Simple leaves and beautiful pink/red fruit. <a href="#">Great Plant Pick</a>
<i>Stewartia monodelpha</i> Orange Bark Stewartia	30	20	Yes	5			Extraordinary cinnamon colored bark – avoid hot, dry sites. <a href="#">Great Plant Pick</a>
<i>Stewartia psuedocamellia</i> Japanese Stewartia	25	15	Yes	5			Patchwork bark, white flower in spring. <a href="#">Great Plant Pick</a>
<i>Styrax obassia</i> Fragrant Styrax	25	20	Yes	5			Smooth gray bark and fragrant white flowers. <a href="#">Great Plant Pick</a>

Page intentionally left blank.

# APPENDIX H – INFILTRATION TEST METHODS

Page intentionally left blank.



Methods in this appendix may be used for Medium Impact Projects.

## Small-Scale PIT

Resource: SWMMWW 2014, Vol II 3.3.6, adapted for medium impact projects within the City of Shoreline

### CONDUCTING A PILOT INFILTRATION TEST

Small-scale PIT can be used instead of a large-scale PIT when:

- The drainage area to the infiltration site is less than 1 acre
- The testing is for the LID BMP's of bioretention or permeable pavement that serve small scale drainage areas and/or are widely dispersed throughout a project site
- The site has a high infiltration rate, making a full-scale PIT difficult, and the site geotechnical investigation suggests uniform subsurface characteristics

Excavate the test pit to the estimated surface elevation of the proposed infiltration facility. In the case of bioretention, excavate to the estimated elevation at which the imported soil mix will lie on top of the underlying native soil. For permeable pavements, excavate to the elevation at which the imported subgrade materials, or the pavement itself, will contact the underlying native soil. If the native soils (road subgrade) will have to meet a minimum subgrade compaction requirement, compact the native soil to that requirement prior to testing. Note that the permeable pavement design guidance recommends compaction not exceed 90% - 92%. Finally, lay back the slopes sufficiently to avoid caving and erosion during the test. Alternatively, consider shoring the sides of the test pit.

- The horizontal surface area of the bottom of the test pit should be 12 to 32 square feet. It may be circular or rectangular, but accurately document the size and geometry of the test pit

Install a vertical measuring rod adequate to measure the ponded water depth and that is marked in half inch increments in the center of the pit bottom. Use a rigid pipe with a splash

plate on the bottom to convey water to the pit and reduce side-wall erosion or excessive disturbance of the pond bottom. Excessive erosion and bottom disturbance will result in clogging of the infiltration receptor and yield lower than actual infiltration rates. Use a 3-inch diameter pipe for pits on the smaller end of the recommended surface area, and a 4-inch pipe for pits on the larger end of the recommended surface area.

During pre-soak period, add water to the pit so that there is standing water for at least 6 hours. Maintain the pre-soak water level at least 12 inches above the bottom of the pit. At the end of the pre-soak period, add water to the pit at a rate that will maintain a 6-12 inch water level above the bottom of the pit over a full hour. The depth should not exceed the proposed maximum depth of water expected in the completed facility.

- Every 15 minutes, record the cumulative volume and instantaneous flow rate in gallons per minute necessary to maintain the water level at the same point (between 6 inches and 1 foot) on the measuring rod. The specific depth should be the same as the maximum designed ponding depth (usually 6 – 12 inches)
- After one hour, turn off the water and record the rate of infiltration (the drop rate of the standing water) in inches per hour from the measuring rod data, until the pit is empty.

A self-logging pressure sensor may also be used to determine water depth and drain-down. At the conclusion of testing, over-excavate the pit to see if the test water is mounded on shallow restrictive layers or if it has continued to flow deep into the subsurface. The depth of excavation varies depending on soil type and depth to hydraulic restricting layer, and is determined by the engineer or certified soils professional. The soils professional should judge whether a mounding analysis is necessary.

## DATA ANALYSIS

Calculate and record the saturated hydraulic conductivity rate in inches per hour in 30 minutes or one-hour increments until one hour after the flow has stabilized.

## Grain Size Analysis

Resource: SWMMWW 2014, Vol II 3.3.6, adapted for medium impact projects within the City of Shoreline

### METHOD

For each defined layer below the infiltration pond to a depth below the pond bottom of 2.5 times the maximum depth of water in the pond, but not less than 10 feet, estimate the initial saturated hydraulic conductivity ( $K_{sat}$ ) in cm/sec using the following relationship (see Massmann 2003, and Massmann et al., 2003).

$$\log_{10}(K_{sat}) = -1.57 + 1.90D_{10} + 0.015D_{60} - 0.013D_{90} - 2.08f_{fines}$$

Where,  $D_{10}$ ,  $D_{60}$  and  $D_{90}$  are the grain sizes in mm for which 10 percent, 60 percent and 90 percent of the sample is more fine and  $f_{fines}$  is the fraction of the soil (by weight) that passes the number-200 sieve ( $K_{sat}$  is in cm/s).

For bioretention facilities, analyze each defined layer below the top of the final bioretention area subgrade to a depth of at least 3 times the maximum ponding depth, but not less than 3 feet (1 meter). For permeable pavement, analyze for each defined layer below the top of the final subgrade to a depth of at least 3 times the maximum ponding depth within the base course, but not less than 3 feet (1 meter).

This equation for estimating  $K_{sat}$  assumes minimal compaction consistent with the use of tracked (i.e., low to moderate ground pressure) excavation equipment.

If the soil layer being characterized has been exposed to heavy compaction (e.g., due to heavy equipment with narrow tracks, narrow tires, or large lugged, high pressure tires) the hydraulic conductivity for the layer could be approximately an order of magnitude less than what would be estimated based on grain size characteristics alone (Pitt, 2003). In such cases, compaction effects must be taken into account when estimating hydraulic conductivity.

For clean, uniformly graded sands and gravels, the reduction in  $K_{sat}$  due to compaction will be much less than an order of magnitude. For well graded sands and gravels with moderate to

high silt content, the reduction in  $K_{sat}$  will be close to an order of magnitude. For soils that contain clay, the reduction in  $K_{sat}$  could be greater than an order of magnitude.

If greater certainty is desired, the in-situ saturated conductivity of a specific layer can be obtained through the use of a pilot infiltration test (PIT). Note that these field tests generally provide a  $K_{sat}$  combined with a hydraulic gradient. In some of these tests, the hydraulic gradient may be close to 1.0; therefore, in effect, the test infiltration rate result is the same as the hydraulic conductivity. In other cases, the hydraulic gradient may be close to the gradient that is likely to occur in the full-scale infiltration facility. The hydraulic gradient will need to be evaluated on a case-by-case basis when interpreting the results of field tests. It is important to recognize that the gradient in the test may not be the same as the gradient likely to occur in the full-scale infiltration facility in the long-term (i.e., when ground water mounding is fully developed).

Once the  $K_{sat}$  for each layer has been identified, determine the effective average  $K_{sat}$  below the pond.  $K_{sat}$  estimates from different layers can be combined using the harmonic mean:

(equation 2):

$$K_{equiv} = \frac{d}{\sum \frac{d_i}{K_i}}$$

Where,  $d$  is the total depth of the soil column,  $d_i$  is the thickness of layer “ $i$ ” in the soil column, and  $K_i$  is the saturated hydraulic conductivity of layer “ $i$ ” in the soil column. The depth of the soil column,  $d$ , typically would include all layers between the pond bottom and the water table. However, for sites with very deep water tables (>100 feet) where ground water mounding to the base of the pond is not likely to occur, it is recommended that the total depth of the soil column in Equation 2 be limited to approximately 20 times the depth of pond, but not more than 50 feet. This is to ensure that the most important and relevant layers are included in the hydraulic conductivity calculations. Deep layers that are not likely to affect the infiltration rate near the pond bottom should not be included in Equation 2.

Equation 2 may over-estimate the effective  $K_{sat}$  value at sites with low conductivity layers immediately beneath the infiltration pond. For sites where the lowest conductivity layer is within five feet of the base of the pond, it is suggested that this lowest  $K_{sat}$  value be used as the equivalent hydraulic conductivity rather than the value from Equation 2. Using the layer with the

lowest  $K_{sat}$  is advised for designing bioretention facilities or permeable pavements. The harmonic mean given by Equation 2 is the appropriate effective hydraulic conductivity for flow that is perpendicular to stratigraphic layers, and will produce conservative results when flow has a significant horizontal component such as could occur due to ground water mounding.

## Correction Factors

Resource: SWMMWW 2014, Vol II 3.4, adapted for medium impact projects within the City of Shoreline

### APPLICATION TO BIORETENTION

If deemed necessary by a qualified professional engineer, a correction factor may be applied to the measured  $K_{sat}$  of the subgrade soils to estimate its design (long term) infiltration rate.

The overlying bioretention soil mix provides excellent protection for the underlying native soil from sedimentation. Accordingly, the correction factor for the sub-grade soil does not have to take into consideration the extent of influent control and clogging over time. The correction factor to be applied to in-situ, small-scale infiltration test results is determined by the number of tests in relation to the number of bioretention areas and site variability. Correction factors range from 0.33 to 1 (no correction) and are determined by a licensed geotechnical engineer or licensed engineering geologist.

Tests should be located and be at an adequate frequency capable of producing a soil profile characterization that fully represents the infiltration capability where the bioretention areas are to be located. The correction factor depends on the level of uncertainty that variable subsurface conditions justify. If a pilot infiltration test is conducted for all bioretention areas or the range of uncertainty is low (for example, conditions are known to be uniform through previous exploration and site geological factors) one pilot infiltration test may be adequate to justify a correction factor of one. If the level of uncertainty is high, a correction factor near the low end of the range may be appropriate. Two example scenarios where low correction factors may apply include:

- Site conditions are highly variable due to a deposit of ancient landslide debris, or buried stream channels. In these cases, even with many explorations and several pilot infiltration tests, the level of uncertainty may still be high.
- Conditions are variable, but few explorations and only one pilot infiltration test is conducted. That is, the number of explorations and tests conducted do not match the degree of site variability anticipated.

### Correction Factors for in-situ Saturated Hydraulic Conductivity Measurements to Estimate Design (Long-Term) Infiltration Rates of Subgrade Soils Underlying Bioretention

Site Analysis Issue	Correction Factor
Site variability and number of locations tested	$CF_v = 0.33$ to 1
Degree of influent control to prevent siltation and bio-buildup	No correction factor required

#### APPLICATION TO PERMEABLE PAVEMENT

The correction factor for in-situ, small-scale pilot infiltration test is determined by the number of tests in relation to the size of the permeable pavement installation, site variability and the quality of the aggregate base material. Correction factors range from 0.33 to 1 (no correction).

Tests should be located and be at adequate frequency capable of producing a soil profile characterization that fully represents the infiltration capability where the permeable pavement is located. If used, the correction factor depends on the level of uncertainty that variable subsurface conditions justify. If enough pilot infiltration tests are conducted across the permeable pavement subgrade to provide an accurate characterization, or the range of uncertainty is low (for example, conditions are known to be uniform through previous exploration and site geological factors), then a correction factor of one for site variability may be justified. Additionally, a correction factor of 1 for the quality of pavement aggregate base

material may be necessary if the aggregate base is clean washed material with 1% or less fines passing the 200 sieve.

If the level of uncertainty is high, a correction factor near the low end of the range may be appropriate. Two example scenarios where low correction factors may apply include:

Site conditions are highly variable due to a deposit of ancient landslide debris, or buried stream channels. In these cases, even with many explorations and several pilot infiltration tests, the level of uncertainty may still be high.

Conditions are variable, but few explorations and only one pilot infiltration test is conducted. That is, the number of explorations and tests conducted do not match the degree of site variability anticipated.

Table III-3.4.2 Correction Factors for in-situ Saturated Hydraulic Conductivity ( $K_{sat}$ ) Measurements to Estimate Design (Long-Term) Infiltration Rates

Site Analysis Issue	Correction Factor
Site variability and number of locations tested	$CF_v = 0.33$ to 1
Quality of pavement aggregate base material	$CF_m = 0.9$ to 1

Total correction factor ( $CF_T$ ) =  $CF_v \times CF_m$

Page intentionally left blank.



# APPENDIX I - RECORD DRAWING CRITERIA

Page intentionally left blank.

## Record Drawing Requirements (As-Builts)

- A. Record drawings are required prior to request for final inspection or issuance of Certificate of Occupancy for all right-of-way construction projects and for surface water drainage systems that connect to City infrastructure.
- B. Record drawings should accurately reflect revisions made to approved plans during construction. The record drawings should locate all newly installed, existing, and abandoned utilities encountered during construction, but not shown on the approved plans.
- C. Record drawings must be stamped, signed, and dated by a State of Washington Registered Engineer.
- D. As-constructed survey information provided on a record drawing shall be provided by a licensed land surveyor. Information from sources such as the contractor's red-lined drawings, for which the surveyor is not responsible, shall be clearly noted/identified on the face of the record drawings.
- E. The Permittee shall provide the City inspector preliminary record drawings on paper. Once the City approves the preliminary submittal, the Permittee provides the final drawings in the following formats. Each plan sheet shall bear the engineer and the surveyor stamps, signature, and date signed:
  - Paper;
  - Mylar (24" by 36");
  - AutoCAD format; and
  - PDF electronic file
- F. Each sheet of the record drawings shall include the following statement, preferably located in the bottom right hand corner of the each sheet.

**"These plans are record drawings and the information shown accurately reflects existing field conditions as of this date \_\_\_\_\_."**

## CAD GUIDELINES

### 2.1 Electronic Submittals:

The City of Shoreline is currently using AutoCAD Civil 3D 2014.

Xref file (External reference files) = these are other files that are linked to the main drawing such as other drawings and images

\*.ctb files = this is the color settings file. This is VERY helpful to have because it defines the layers and line weights on the drawings

PDF file of the complete drawing

### 2.2 Survey info:

Horizontally referenced to WA State Plane Coordinates, North Zone, NAD 83 HARN GCS 4602 in Survey Feet

Vertically referenced to NAVD 1988, feet

Provide eastings and northings for existing and new monuments and benchmarks in the coordinate system referenced, as an embedded or separate table

### 2.3 Drafting Guidelines:

Layering Designations in CAD Files should be separated and delineated for storm facilities (separate layers for pipes, catch basins and other structures), water utilities, sanitary sewer utilities, buildings, pavement edges, sidewalks, curb ramps, water bodies, wetlands, poles, trees, property lines, ROW boundaries, luminaires, signs, pavement markings, traffic signals, barriers, handrails, guard rails, landscape areas and fences

All lines should be snapped and closed, and attributes should be defined on Layer 0.

Drawings shall be purged of empty, unused, or non-essential drawing data.

Drawings should be in full scale format (1ft =1ft)

### 2.4 Layout Management:

All elements should be created in Model space. Our GIS software does not draw features created in Paper space.

# APPENDIX J – STREET LIGHTING LEVELS CRITERIA

Page intentionally left blank.

## Lighting Level Requirements

ROADWAY CLASSIFICATION	Area Classification <sup>n1</sup>	Target Light Levels		Luminaire Mounting Height (ft)	Maximum Arm Length (ft)	Maximum Wattage <sup>4</sup>
		Minimum Maintained Average (fc)	Uniformity Ratio (Avg/Min)			
PRINCIPAL ARTERIAL	Commercial	1.6	3:1	40	12	271
	Residential	0.8	3:1	40 <sup>3</sup>	16	271
				35 <sup>2</sup>	12	183
MINOR ARTERIAL	Commercial	1.1	3:1	40	12	271
	Residential	0.5	4:1	35 <sup>3</sup>	12	183
				35 <sup>2</sup>	12	135
COLLECTOR ARTERIAL	Commercial	1.1	3:1	40	12	271
	Residential	0.6	4:1	35	12	135
LOCAL STREET	Commercial	0.8	6:1	35	12	183
	Residential	0.4	6:1	25	12	92
		Decision Point Lighting <sup>5</sup>		12-35	n/a	112

1. See City of Shoreline Zoning Map; Industrial, Business, and Mixed Business are to be considered Commercial. All others, including Mixed Use are considered residential for the purposes of lighting standards.
2. Use for roadway width of 36 ft or less
3. Use for roadway width over 36 ft
4. Maximum wattage values are for LED fixtures only. Coordinate with City of Shoreline for High Pressure Sodium and Metal Halide maximum wattage values.
5. Decision Point Lighting may be applied to residential local access streets with 300 ft maximum spacing between luminaires. Luminaires are placed at intersections, crossings, changes in roadway geometry, dead ends, hazards, etc.