



Planning & Community  
Development

17500 Midvale Avenue North  
Shoreline, WA 98133-4905  
206-801-2500 [phone]  
206-801-2788 [fax]  
pcd@shorelinewa.gov  
www.shorelinewa.gov

# Stairway - Residential



## Residential Stairway Information

- See sections R311 through R312 of the *International Residential Code* for specific requirements.
- Stairway width is 36" minimum.
- Guardrails are required on open sides of stair with a total rise of more than 30" above the floor or finished grade.
- Handrails are to be provided on at least one side of each continuous run of treads or flight with four or more risers. Handrails may not project more than 4.5" on either side of the stairway.
- A floor or landing (36" x 36") must be provided at the top and bottom of each stairway. (Not required at the top of an interior flight of stairs, provided a door does not swing over the stairs.)
- All stairways require a minimum headroom of 6'-8".
- Interior and exterior stairways must be illuminated including landings and treads (R306.6).

### Hours of Operation:

Monday 8:00 am-5:00 pm  
Tuesday 8:00 am-5:00 pm  
Wednesday 1:00 pm-5:00 pm  
Thursday 1:00 pm-5:00 pm  
Friday 8:00 am-5:00 pm  
**Permit Processing Ends at 4:00 pm Daily**

See Diagrams on the following page

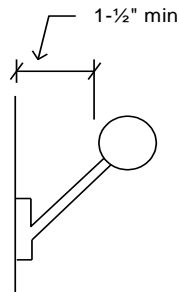
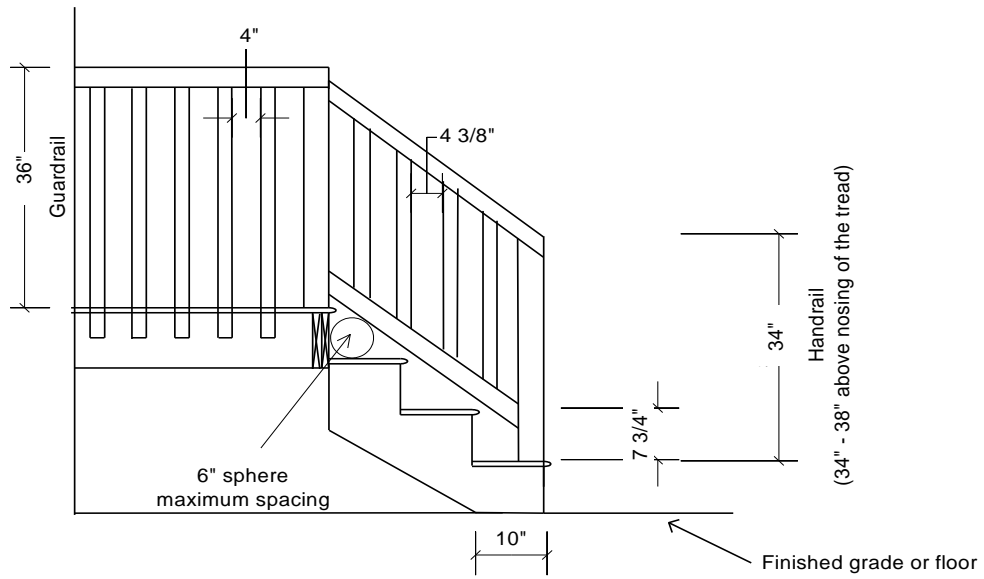

Handrail 1-1/4" to 2" diameter - return ends to wall or other approved method of termination

See R311.5.6.3 for other permitted handrail shapes

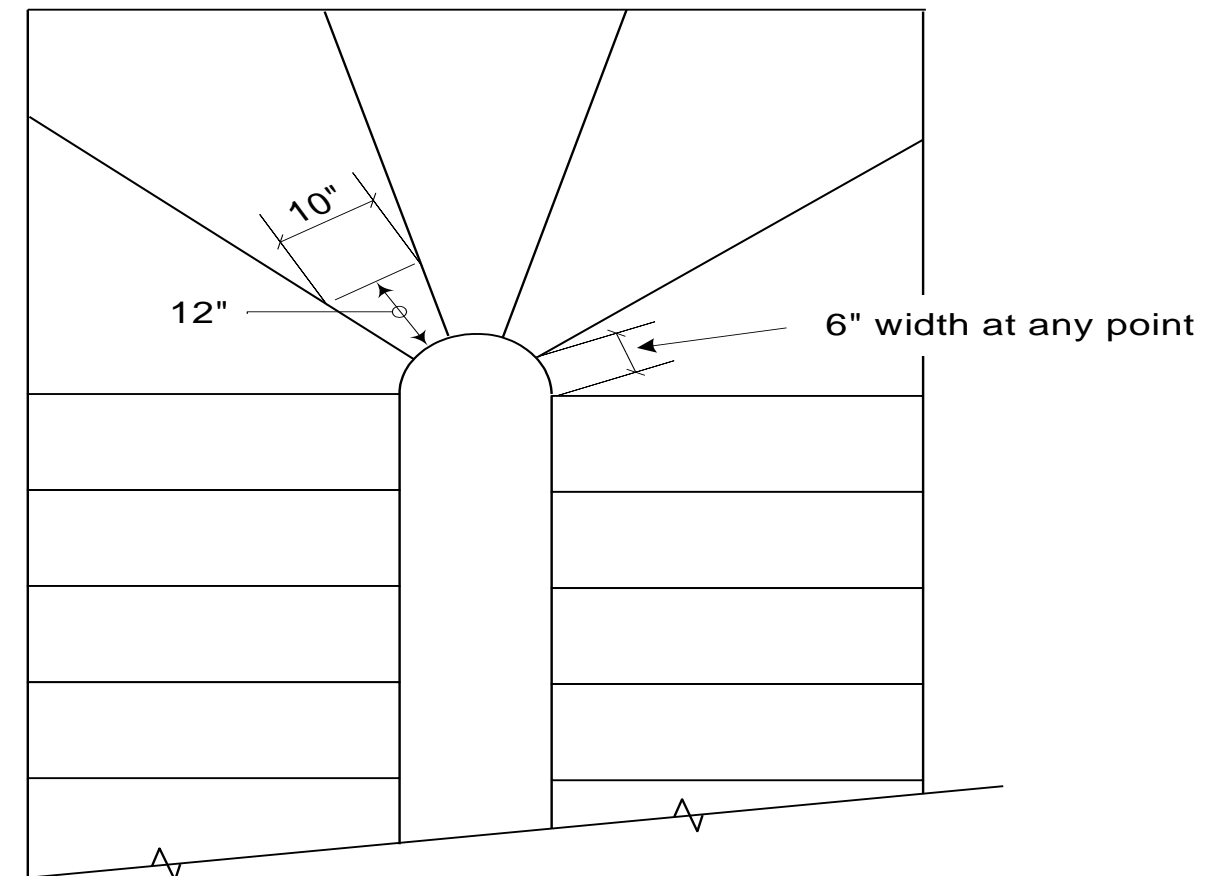

Typical winder detail. Minimum stairway width of 36 inches must be maintained.