

## DEPARTURE REQUESTS

#	Land Use Code	Code Item	Code Requirement	Departure Request	Design Rationale
<b>Site Development Standards</b>					
Departures related to site design dimensional requirements					
D1	20.50.240.C.1.e	Site Design - Site Frontage	A building's primary entry shall be located on a street frontage and recessed to prevent door swings over sidewalks, or an entry to an interior plaza or courtyard from which building entries are accessible;	Allow for building entries along Westminster Way and N 160th Street to be accessed from an internal public open space with a pedestrian connection to the public right of way.	Significant grade changes along both Westminster Way and N160th do not allow for all primary building entries to be located on the street frontage. Where physically feasible, building entries are located near site entry drives and connected to the public right-of-way by an accessible pathway through a public open space.  <a href="#">Primary entries indicated in red and clouded on Departure Exhibit D1</a>
D2	20.50.240.E.1.a	Site Design - Internal Site Walkways	All development shall provide clear and illuminated pathways between the main building entrance and a public sidewalk. Pathways shall be separated from motor vehicles or raised six inches and be at least 8 feet wide	Allow for sidewalks along private residential streets and pathways not serving commercial uses to be reduced to 6 feet wide.	A 6' wide sidewalk along private residential streets with no commercial frontage would exceed the minimum 5feet wide sidewalk as required per. section 12.8 (Private Streets) of the Shoreline Engineering Manual.
D3	20.50.240.E.1.c	Site Design - Internal Site Walkways	Raised walkways at least eight feet wide shall be provided for every three, double-loaded aisles or every 200 feet of parking area width. Walkway crossings shall be raised a minimum three inches above drive surfaces	Allow for walkways to be provided for every 265 feet of parking lot width provided that no parking stalls is more than 100 feet from a walkway,	A parking lot with three code compliant double-loaded aisles exceed the minimum 200 feet aisle separation. The proposed site design creates a framework of well connected pedestrian scaled blocks that serves uses on multiple sides. The largest proposed distance between walkways is greater than 200 feet, however no stall is more than 100 feet from a walkway which is consistent with the intent of the code requirements.  <a href="#">Proposed Departure supported by Departure Exhibit D3</a>
D4	20.50.410.H	Parking design standards	Parking spaces abutting a landscaped area on the shall provide an additional 18 inches to provide a place to step other than in the landscaped area. In a parking garage, any space abutting a wall shall provide an additional 18 inches.	Allow for the required 18" step-off to be provided with a 12" paving strip inside the 6" curb.	This departure would still achieve the goal of not requiring a driver or passenger to step into a landscape area, but onto a durable surface. This is the same condition that occurs at parallel street parking.  <a href="#">Proposed Departure supported by Departure Exhibit D4</a>
D5	20.50.410.F	Parking design standards	Stall size (width x length) to be: <ul style="list-style-type: none"> <li>Desired: 9' x 20'</li> <li>Minimum: 8.5' x 20'</li> <li>Compact: 8' x 16'</li> </ul> Note: up to 50% of stalls allowed to be compact stalls	Allow for the following stall sizes (width x length): <ul style="list-style-type: none"> <li>Desired: 9' x 18'</li> <li>Minimum: 8' x 16'</li> <li>Compact: 7.5' x 15'</li> </ul> Note: up to 50% of stalls allowed to be compact stalls	The site design recognizes that transient users require larger parking stalls due to the higher turn-over rate. With this in mind, the site plan includes a combination of 9'x 20' and 9' x 18' commercial stalls with a less than 25% of stalls being 9' x17'. Smaller stall sizes, specifically within residential buildings are more consistent with the urban character of the development and the goal of increasing land efficiency as outlined in the CRA.
<b>Building Development Standards</b>					
Departures related to site design dimensional requirements					
D6	Table 20.50.020(3)	Dimensional Requirements	Base height dimensions for Development in Mixed Business Commercial Zones MB is 70'.	Allow for a proposed base height of 80'.	Generally, the proposed development is conceived as 5 floors wood frame construction over 2 floors of type 1 construction. The existing site grades change by nearly 20' from the northwest to the southeast corner of the site. Due to the existing grades changes and a trend of 9' ceiling heights in the luxury residential market, some of the building heights may ultimately exceed the current allowable base height. The building code would still limit the maximum occupied floor level of any building to 75' to avoid high rise construction requirements.

## DEPARTURE REQUESTS

D7	20.50.250.B.3	Building Design - Building Articulation	Provide the following articulation features at least every 35 feet of facade facing a street, park, public place, or open space. Parking structure facades fronting public streets shall apply to this subsection only as material, color, texture, or opening modulations and not as offset modulations: a. Vertical building modulation 18 inches deep and four feet wide, if combined with a change in color or building material. Otherwise, the minimum depth of modulation is 10 feet and the minimum width for each modulation is 15 feet. Balconies may be used to meet modulation; and b. Distinctive ground or first floor facade, consistent articulation of middle floors, and a distinctive roof line or articulate on 35-foot intervals.	Allow for required building articulation to occur at least every 80 feet of facade facing a street, park, public place, or open space.	Building articulation, while necessary for any successful design expression, needs to be appropriately scaled to the size of development to which it is being applied. The strict application of a 35' modulation interval on a more than 250' facade would lead to a monotonous design language. A 35 feet articulation module is more appropriately scaled to smaller multifamily residential and town home developments, rather than the vibrant center described in the Aurora Square CRA. The request for a departure to an 80 feet articulation module is consistent with the requirements for Commercial buildings set forth in 20.50.250.B.2 of the Shoreline Development standards.  <a href="#">Proposed Departure supported by Departure Exhibit D7</a>
D8	20.50.250.B.5	Building Design - Building Articulation	Every 150 feet in building length along the street front shall have a minimum 30-foot-wide section that is offset by at least 20 feet through all floors.	Every 150 feet in building length along the street front shall have a minimum 30-foot-wide section that is offset by at least 10 feet through all floors above the ground level floor.	Extending the required building articulation down to the ground level interrupts the consistency of the urban street frontage. A departure from this requirement would enhance the ground level experience as envisioned in the Aurora Square CRA.  <a href="#">Proposed Departure supported by Departure Exhibit D8</a>

DEPARTURE EXHIBITS



D1 -- Departure Request

DEPARTURE EXHIBITS

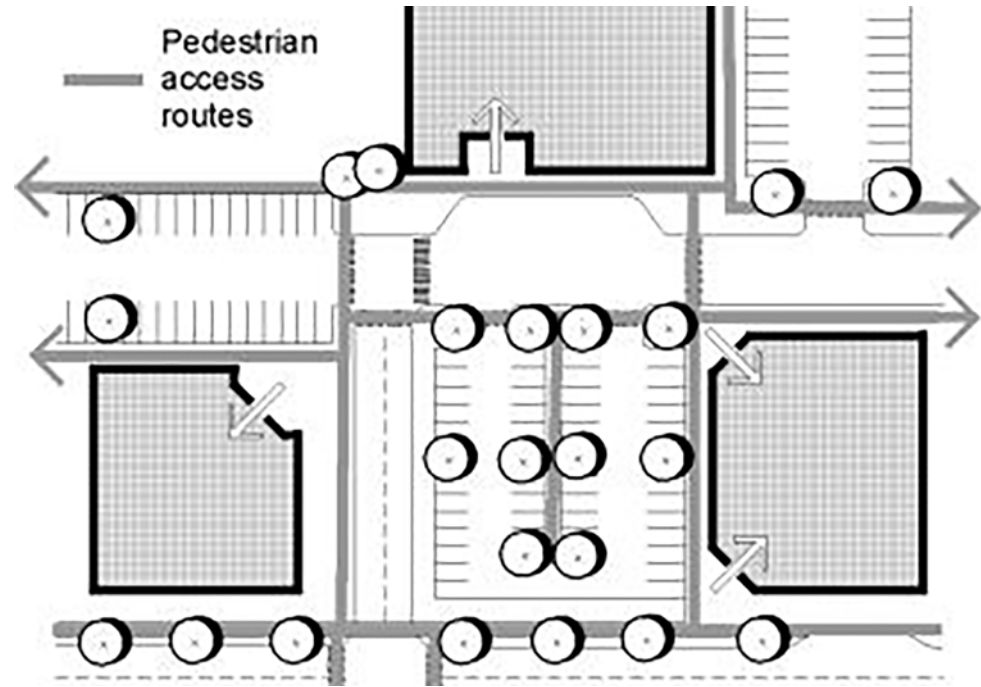

D3 -- Code Compliant Example

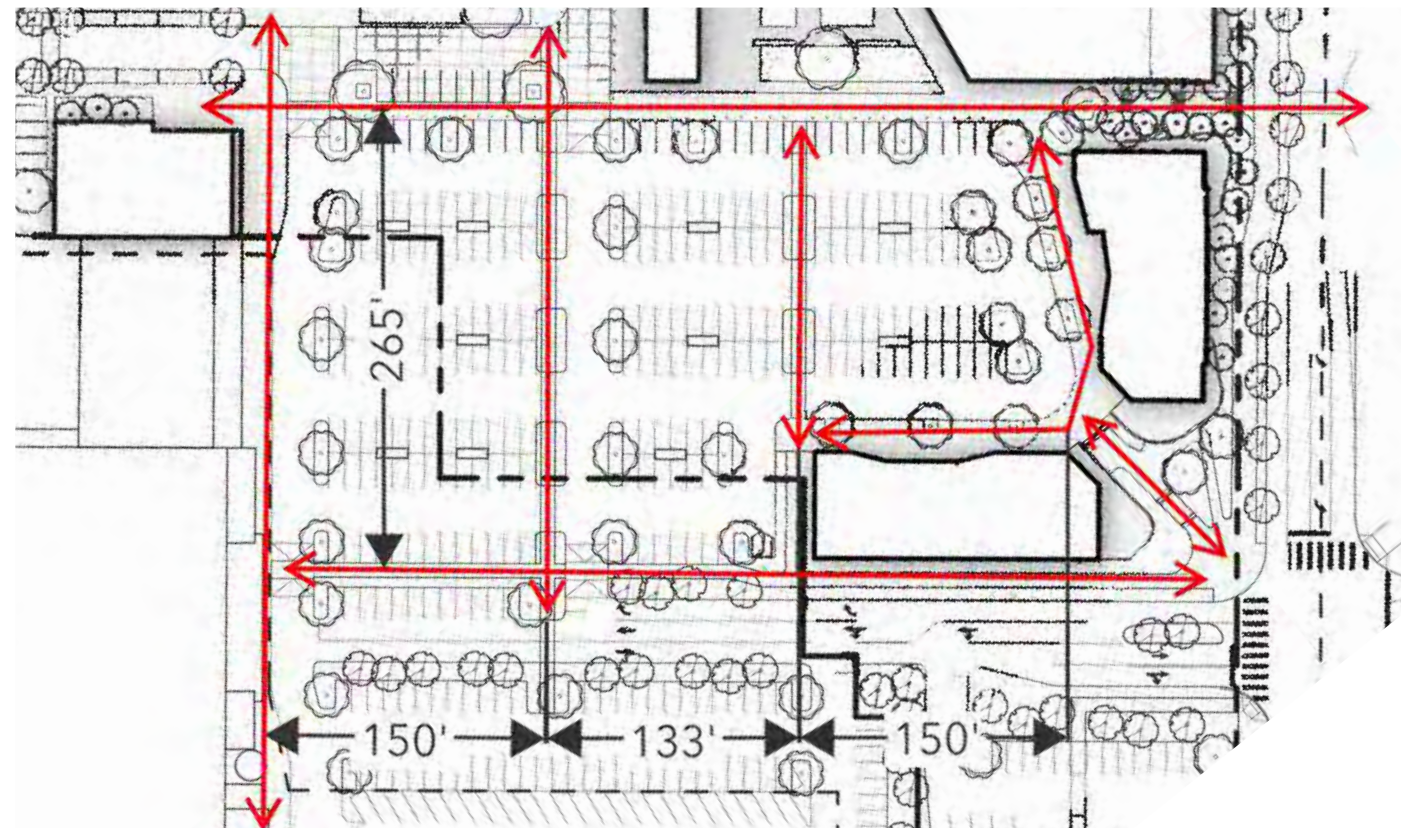

D3 --- Departure Request

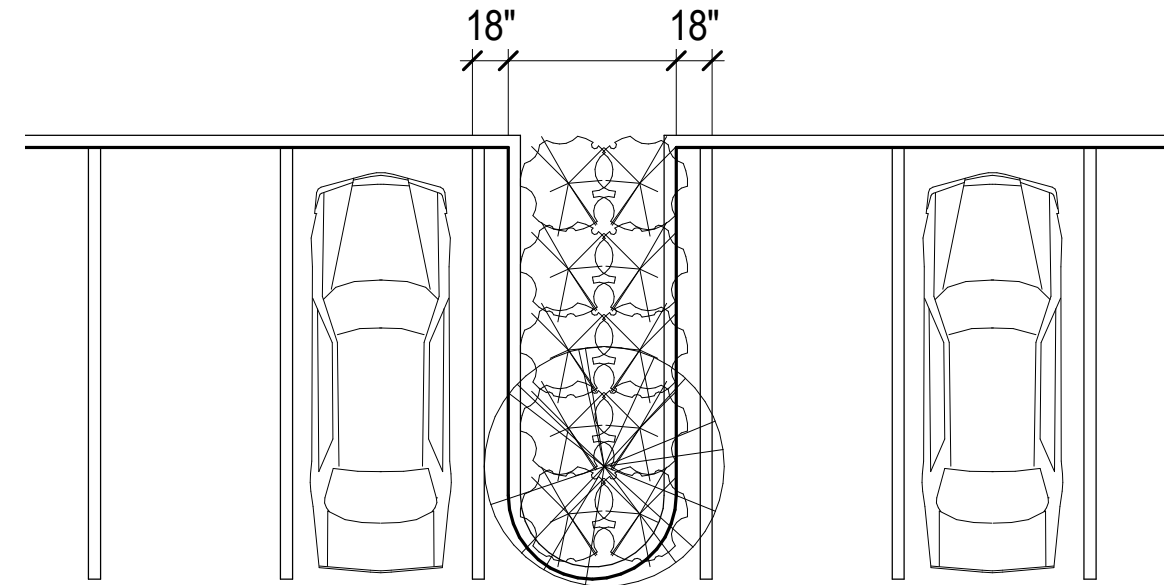

D4 -- Code Compliant Example

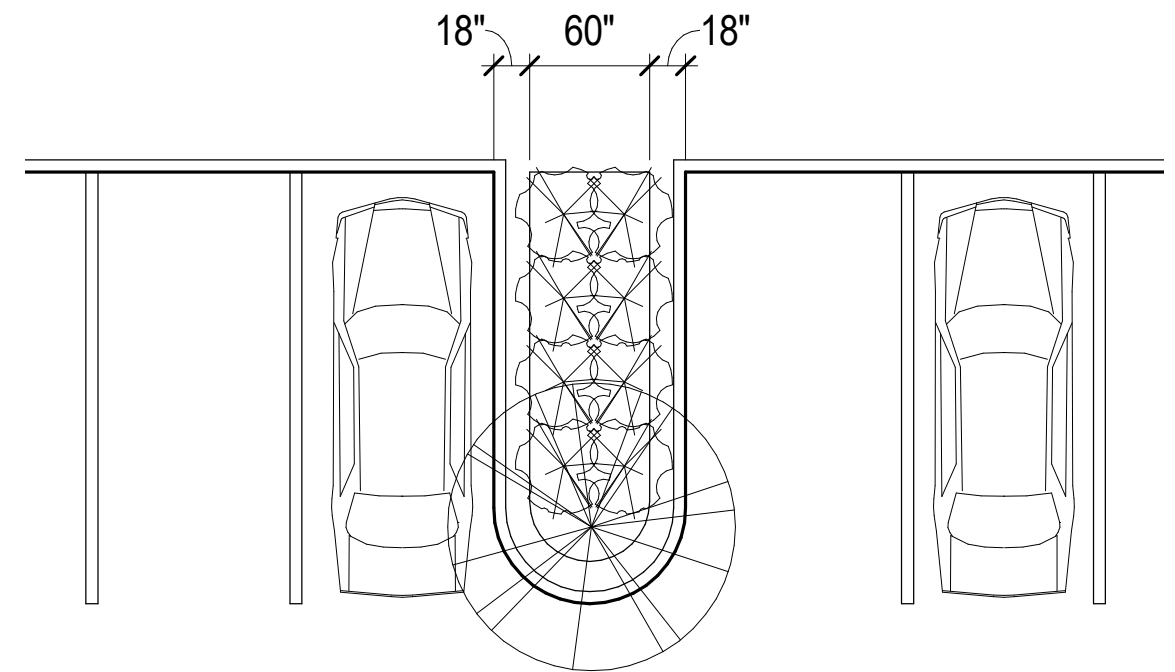

D4 -- Departure Request

DEPARTURE EXHIBITS

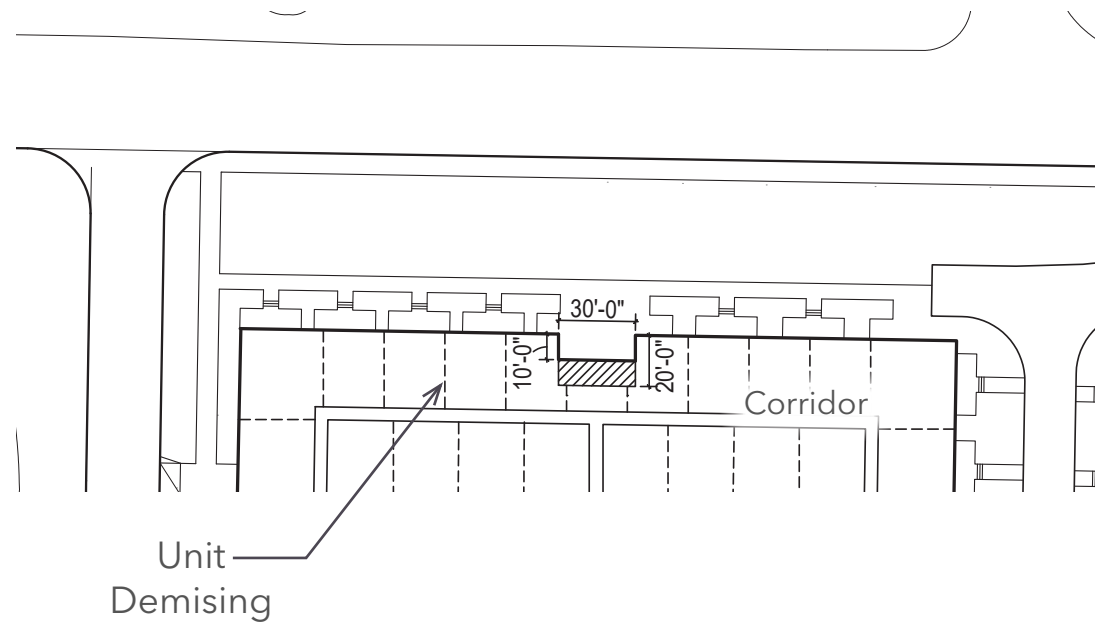

D8 --- Departure Request --- Plan

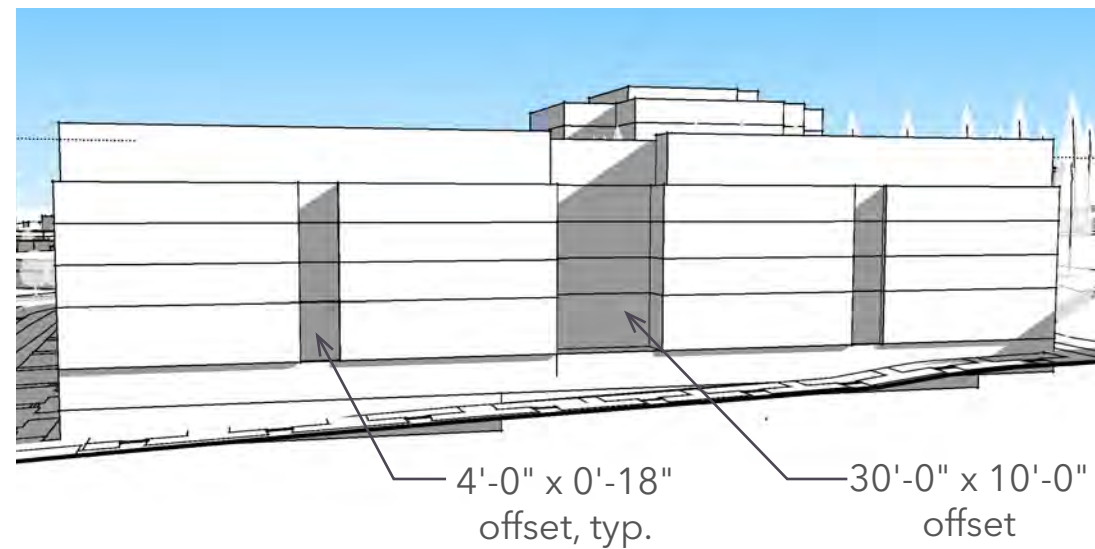

D8 --- Departure Request --- 3D View

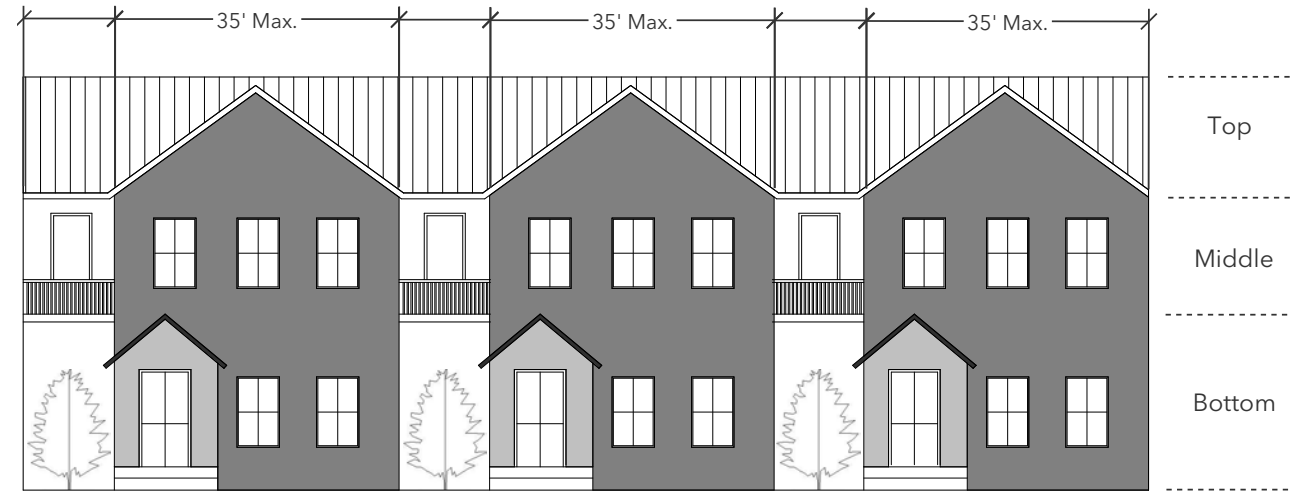

D7 --- Code Compliant Example



D7 --- Departure Request Example